

# DIODE MODULE (F.R.D.)

# FRG25BA60

TOP



UL;E76102 (M)

FRG25BA60 is a high speed (fast recovery) isolated diode module designed for high power switching application. FRG25BA60 is suitable for high frequency application requiring low loss and high speed control.

- High Speed  $t_{rr} \leq 100\text{ns}$
- $I_{F(AV)}$  25A
- Isolated Mounting base.
- High Surge Capability

**(Applications)**

Inverter Welding Power Supply  
 Power Supply for Telecommunication  
 Various Switching Power Supply.

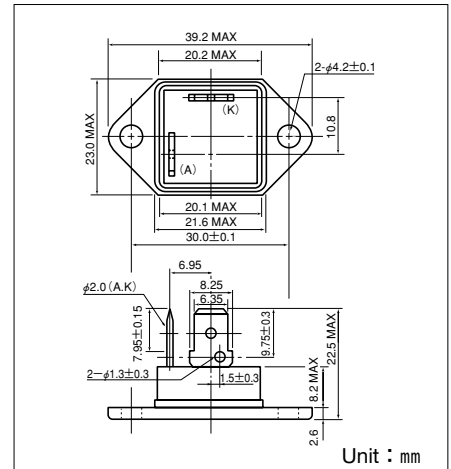
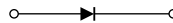

**Maximum Ratings**

( $T_j=25^\circ\text{C}$  unless otherwise specified)

Symbol	Item	Ratings	Unit
		FRG25BA60	
$V_{RRM}$	Repetitive Peak Reverse Voltage	600	V
$V_{R(DC)}$	D.C. Reverse Voltage	480	V

Symbol	Item	Conditions	Ratings	Unit
$I_{F(AV)}$	Forward Current	D.C. $T_c=94^\circ\text{C}$	25	A
$I_{FMS}$	Surge Forward Current	$1/2$ cycle, 60Hz, peak value, non-repetitive	450	A
$I^2t$	$I^2t$	Value for One cycle of surge current	840	$\text{A}^2\text{S}$
$T_j$	Operating Junction Temperature		-40 to +150	$^\circ\text{C}$
$T_{stg}$	Storage Temperature		-40 to +125	$^\circ\text{C}$
$V_{ISO}$	Isolation Breakdown Voltage (R.M.S.)	A.C. 1 minute	2500	V
	Mounting Torque (Mounting M4)	Recommended Value 1.0-1.4 (10-14)	1.5 (15)	$\text{N}\cdot\text{m}$ ( $\text{kgf}\cdot\text{cm}$ )
	Mass	Typical Value	23	g

**Electrical Characteristics**

Symbol	Item	Conditions	Ratings			Unit
			Min.	Typ.	Max.	
$I_{RRM}$	Repetitive Peak Reverse Current	$T_j=150^\circ\text{C}$ , at $V_{RRM}=600\text{V}$		25	30	mA
$V_{FM}$	Forward Voltage Drop	$T_j=25^\circ\text{C}$ , $I_F=25\text{A}$ , Inst. measurement		1.20	1.30	V
$t_{rr}$	Reverse Recovery Time	$I_F=25\text{A}$ , $-di/dt=100\text{A}/\mu\text{s}$		80	100	ns
$R_{th(j-c)}$	Thermal Impedance	Junction to case			1.6	$^\circ\text{C}/\text{W}$

