

# CML Semiconductor Products

PRODUCT INFORMATION

## FX641 Dual Subscriber Private Metering (SPM) Detector

Publication D/641/4 February 2001  
Provisional Issue

### Features

- Two (12kHz/16kHz) SPM Detectors on a Single Chip
- Detects 12kHz and 16kHz SPM Frequencies
- Xtal Accuracy; Stable Frequency Limits
- “Controlled” ( $\mu\text{C}$ ) and “Fixed” Signal Sensitivity Modes
- Selectable Tone Follower or Packet Mode Outputs
- High Speech-Band Rejection Properties
- “Output Enable” Multiplexing Facility
- Call-Charge Applications on PABX Line Cards

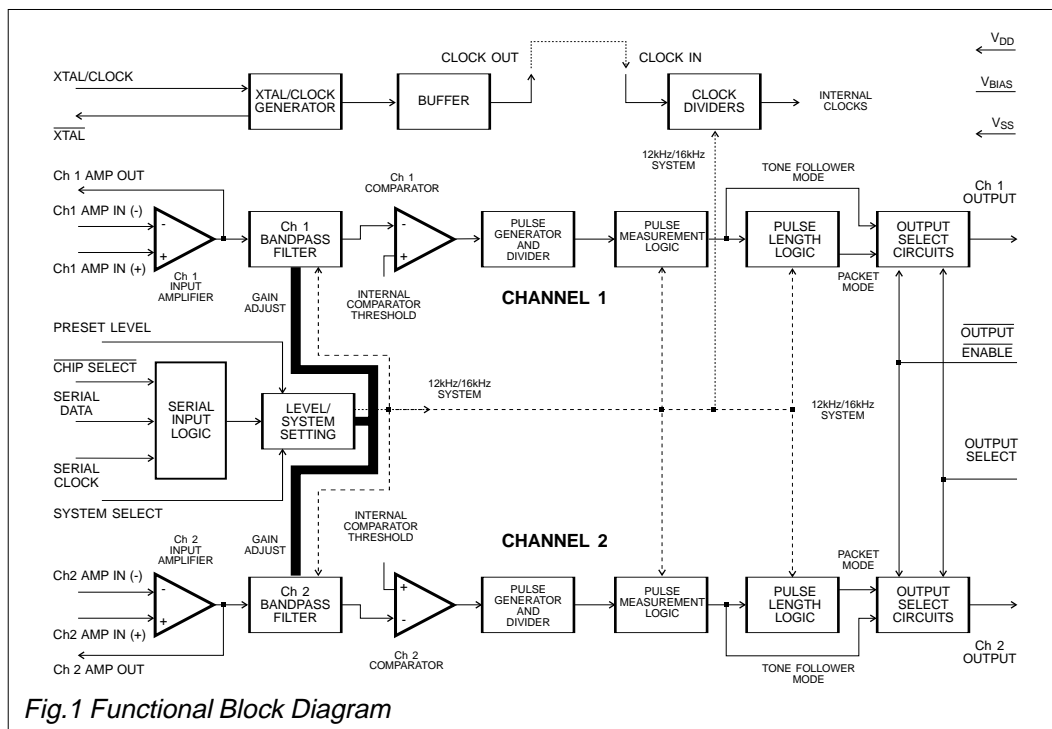

# FX641

### Brief Description

The FX641 is a low-power, system-selectable Dual Subscriber Private Metering (SPM) Detector -two detectors on a single chip- to indicate the presence, on a telephone line, of either 12kHz or 16kHz telephone call-charge frequencies.

Under  $\mu\text{Processor}$  control via a common serial interface, each channel of the FX641 will detect call-charge pulses from a telephone line and provide a digital output for recording, billing or security purposes.

A common set of external components and a stable 3.579545MHz Xtal/clock input ensures that the FX641 adheres accurately to most national “Must and Must-Not” decode band-edges and threshold levels.

The digital output is pin-selectable to one of three modes:

- (1) Tone Follower mode -a logic level for the period of a correct decode.
- (2) Packet mode -respond/de-respond after a cumulative period of tone or notone in a preset period.
- (3) High-impedance output -for device multiplexing.

For non- $\mu\text{Processor}$  systems a preset sensitivity/system input allows external channel level and system setting.

This device, which is suitable for PBX and PABX line-card and remote telephone installations, is available in compact 24-pin plastic DIL and small outline (S.O.I.C.) packages.

The FX641 requires approximately 4.5mA at 5-volts.

## Pin Number

## Function

FX641 D2/P4	
1	<b>Xtal/Clock:</b> The input to the on-chip clock oscillator; for use with a 3.579545MHz Xtal in conjunction with the $\overline{\text{Xtal}}$ output; circuit components are on-chip. When using a Xtal input, the Clock Out pin should be connected directly to the Clock In pin. If a clock pulse input is employed to the Clock In pin, this (Xtal/Clock) pin must be connected directly to $V_{DD}$ (see Figure 2). See Figure 4 for details of clock frequency distribution.
2	$\overline{\text{Xtal}}$ : The output of the on-chip clock oscillator inverter.
3	<b>Clock Out:</b> The buffered output of the on-chip-clock oscillator inverter. If a Xtal input is employed, this output should be connected directly to Clock In pin. This output can support up to 3 additional FX641 microcircuits. See Figure 4 for details of clock frequency distribution.
4	<b>Clock In:</b> The 3.579545 clock pulse input to the internal clock dividers. If an externally generated clock pulse input is employed, the Xtal/Clock input pin should be connected to $V_{DD}$ .
5	<b>Output Enable:</b> For multi-chip output multiplexing; controls the state of both Ch1 and Ch2 outputs. When this input is placed high (logic '1') both outputs are set to a high impedance. When placed low (logic '0') both outputs are enabled.
6	<b>Ch 2 Output:</b> The digital output of the Channel 2 SPM detector when enabled. The format of the signal at this pin, in common with Ch 1, is selectable to either 'Tone Follower' or 'Packet' mode via the Output Select input.
7	<b>Ch 1 Output:</b> The digital output of the Channel 1 SPM detector when enabled. The format of the signal at this pin, in common with Ch 2, is selectable to either 'Tone Follower' or 'Packet' mode via the Output Select input.
8	$V_{BIAS}$ : The output of the on-chip analogue bias circuitry. Held internally at $V_{DD}/2$ , this pin should be decoupled to $V_{SS}$ (see Figure 2).
9	<b>Ch 1 Amp Out:</b> The output of the Channel 1 Input Amplifier. See Figures 2 and 3.
10	<b>Ch 1 Amp In (-):</b> The negative input to the Channel 1 Input Amplifier. See Figures 2 and 3.
11	<b>Ch 1 Amp In (+):</b> The positive input to the Channel 1 Input Amplifier. See Figures 2 and 3.
12	$V_{SS}$ : Negative supply rail (GND).

## Pin Number

## Function

FX641 D2/P4	
13	No internal connection; leave open circuit.
14	<b>Ch 2 Amp In (+):</b> The positive input to the Channel 2 Input Amplifier. See Figures 2 and 3.
15	<b>Ch 2 Amp In (-):</b> The negative input to the Channel 2 Input Amplifier. See Figures 2 and 3.
16	<b>Ch 2 Amp Out:</b> The output of the Channel 2 Input Amplifier. See Figures 2 and 3.
17	<b>Output Select:</b> A logic input to set the Channel 1 and Channel 2 output modes. When high (logic '1'), the outputs are in the Tone Follower mode; when low (logic '0'), the outputs are in the Packet mode.
18	<b>Preset Level:</b> A logic input to set the sensitivity mode of the FX641. When high (logic '1'), both channels are in the Fixed Sensitivity mode. The external components govern the input sensitivity; the System Select input selects 12kHz or 16kHz operation. When low (logic '0'), both channels are in the Controlled Sensitivity mode. Device sensitivities and system selection are via the Chip Select/Serial Data/Serial Clock inputs. This input has an internal pullup resistor on chip (Fixed Sensitivity Mode).
19	<b>Chip Select:</b> The Chip Select input for use in data loading when using the FX641 in the Controlled Sensitivity mode (see Figure 9). The device is selected when this input is set low (logic '0'). When the device is in the Fixed Sensitivity mode this input should be connected to either $V_{SS}$ or $V_{DD}$ .
20	<b>Serial Clock:</b> The Serial Clock input for use in data loading when using the FX641 in the Controlled Sensitivity mode (see Figure 9). Data is loaded to the FX641 on this clock's rising edge. When the device is in the Fixed Sensitivity mode this input should be connected to either $V_{SS}$ or $V_{DD}$ .
21	<b>Serial Data:</b> The Serial Data input for use in data loading when using the FX641 in the Controlled Sensitivity mode (see Figure 9 and Table 2). When the device is in the Fixed Sensitivity mode this input should be connected to either $V_{SS}$ or $V_{DD}$ .
22	<b>System Select:</b> In the Fixed Sensitivity mode this pin selects the system frequency. High (logic '1') = 12kHz; Low (logic '0') = 16kHz. In the Controlled Sensitivity mode this pin should be tied to $V_{DD}$ or left unconnected. This pin has an internal pullup resistor on chip.
23	No internal connection; leave open circuit.
24	<b><math>V_{DD}</math>:</b> Positive supply rail; a single, stable power supply is required. Critical levels and voltages within the FX641 are dependant upon this supply. This pin should be decoupled to $V_{SS}$ by a capacitor mounted close to the pin.

# Application Information

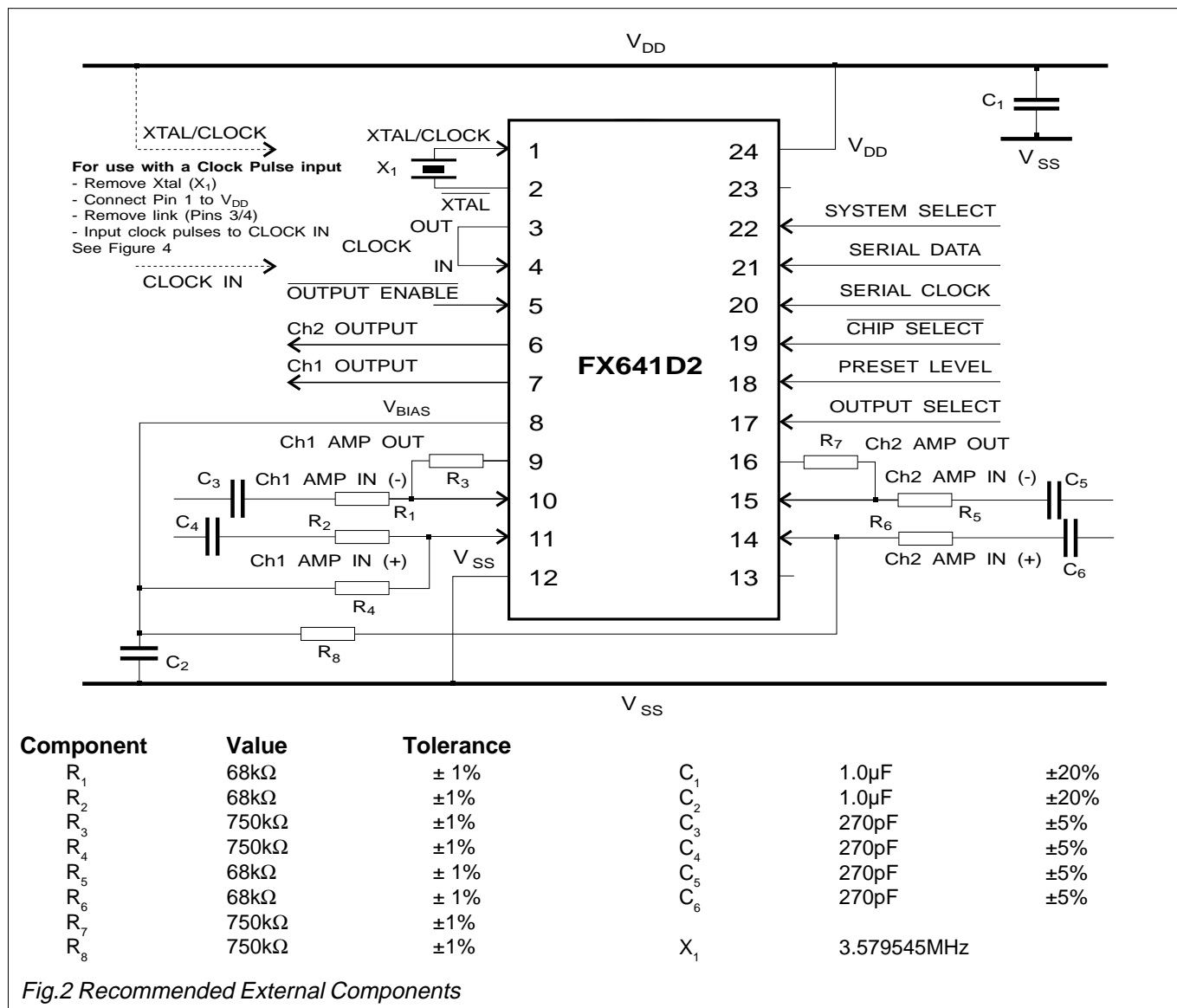

## Fixed Sensitivity Setting

Note that when calculating/selecting gain components, R<sub>3</sub>, R<sub>4</sub>, R<sub>7</sub> and R<sub>8</sub> should always be greater than or equal to 100kΩ.

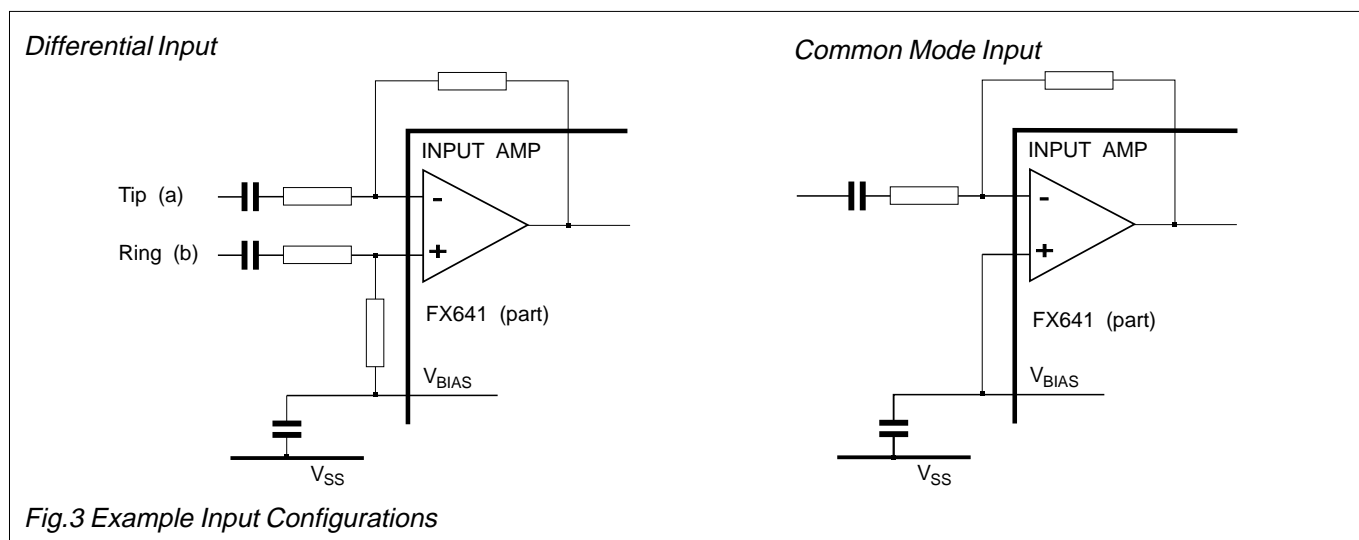

# Application Information .....

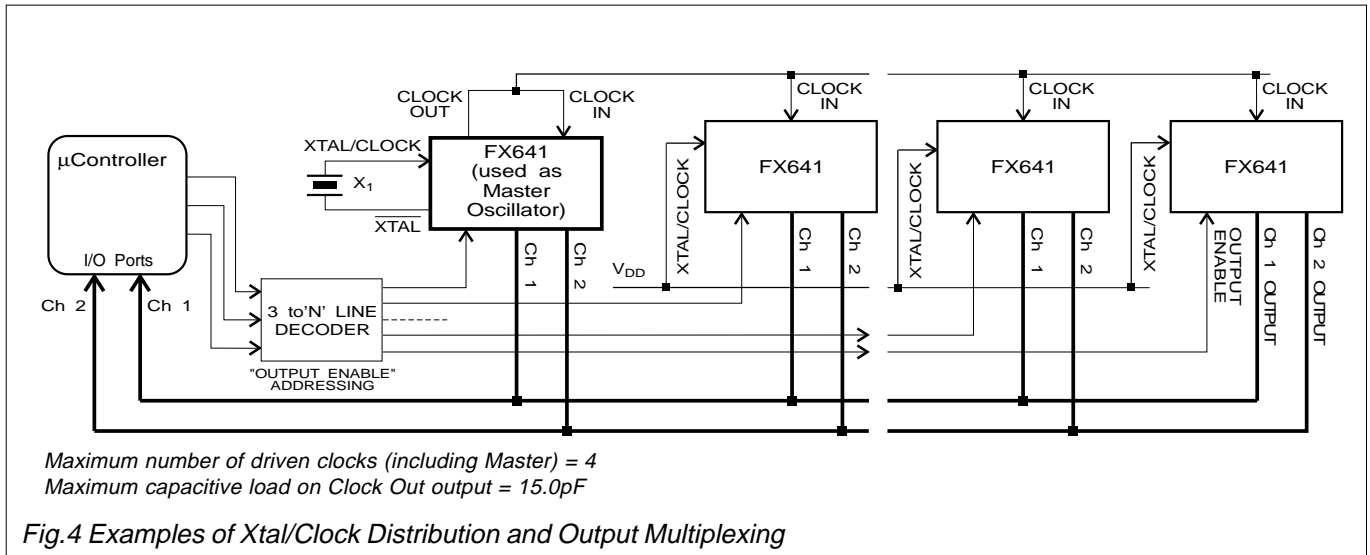

## Xtal/Clock Distribution

The FX641 requires a 3.579545MHz Xtal or clock pulse input. With the exception of the Xtal, all oscillator components are incorporated on chip. If a Xtal input is employed the Clock Out pin should be directly linked to the Clock In pin.

To reduce component and layout complexity, the clock requirements of up to 3 additional FX641 microcircuits may be supplied from a Xtal-driven FX641 acting as the system master clock. With reference to Figure 4, the clock should be distributed as illustrated and the Xtal/Clock pins of the driven microcircuits should be connected directly to  $V_{DD}$ . Note that the maximum load on the master Clock Out pin should not be exceeded.

## Channel Outputs

Channels 1 and 2 outputs operate together under the control of the Output Enable and Output Select inputs. Table 3 describes the operations.

The Front Page description describes the output formats.

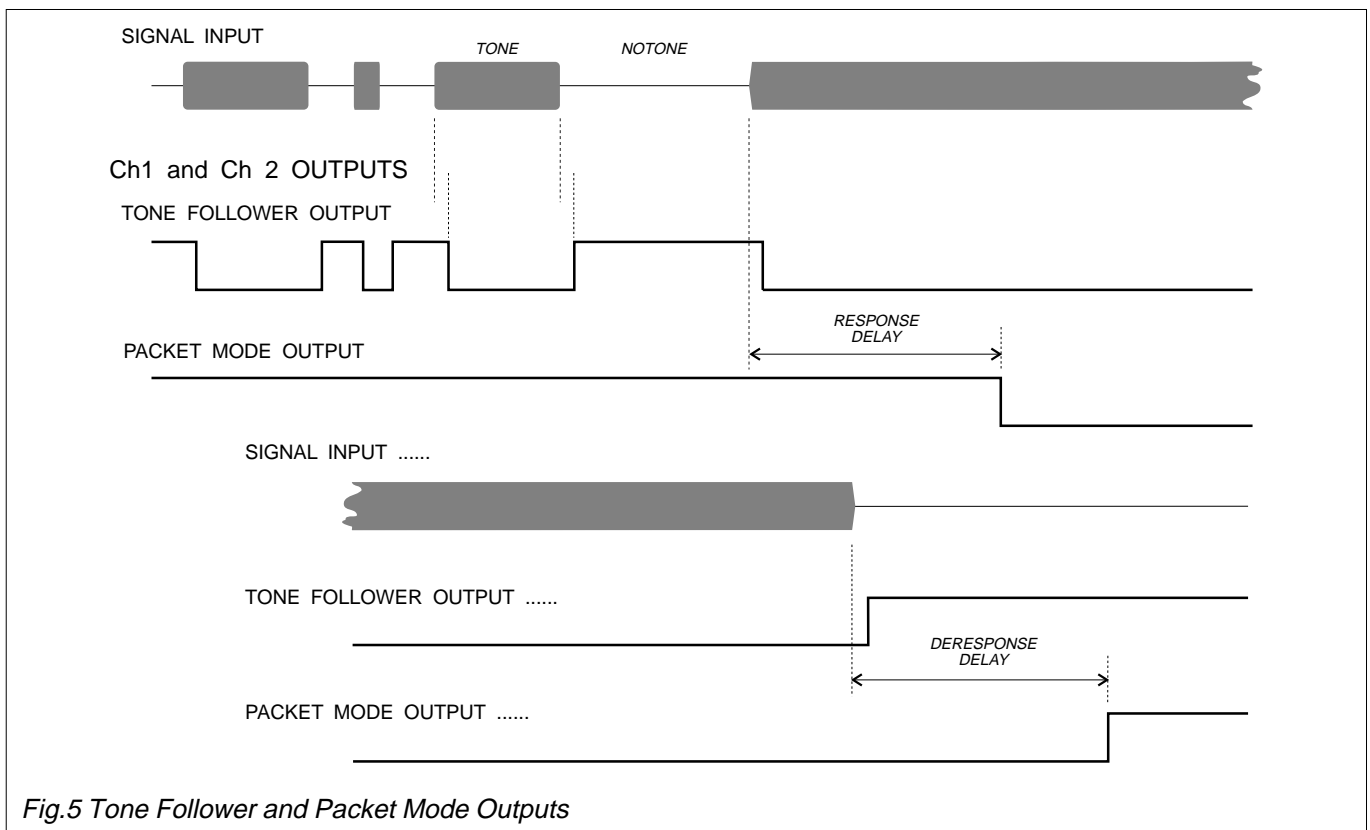

## Application Information .....

### Sensitivity Setting

To enable the FX641 to operate correctly to most national 12kHz and 16kHz SPM specifications, the input sensitivity can be accurately adjusted and set.

There are two different pin-selectable modes of sensitivity setting available to the FX641: Controlled Sensitivity Mode and Fixed Sensitivity Mode

The Controlled Sensitivity mode allows the sensitivity setting from a  $\mu$ Controller via a 6-bit serial data input. This same serial input also sets operation (bit 0) to either 12kHz or 16kHz systems. Both channels are set identically.

The Fixed Sensitivity mode allows the sensitivity of each channel to be set to a fixed "gain" by external components at the input amplifiers. Operation to either 12kHz or 16kHz is by the System Select input.

### Controlled Sensitivity Setting

Serial Data Bits $D_5 - D_1$	Bandpass Filter Gain (dB)	12kHz System Bit $D_0 = '1'$			16kHz System Bit $D_0 = '0'$		
		Minimum Sensitivity dB(ref.)	Nominal Sensitivity dB(ref.)	Maximum Sensitivity dB(ref.)	Minimum Sensitivity dB(ref.)	Nominal Sensitivity dB(ref.)	Maximum Sensitivity dB(ref.)
0 0 0 0 0	0	-16.2	-17.5	-18.8	-16.9	-18.2	-19.5
0 0 0 0 1	1.0	-17.2	-18.5	-19.8	-17.9	-19.2	-20.5
0 0 0 1 0	2.0	-18.2	-19.5	-20.8	-18.9	-20.2	-21.5
0 0 0 1 1	3.0	-19.2	-20.5	-21.8	-19.9	-21.2	-22.5
0 0 1 0 0	4.0	-20.2	-21.5	-22.8	-20.9	-22.2	-23.5
0 0 1 0 1	5.0	-21.2	-22.5	-23.8	-21.9	-23.2	-24.5
0 0 1 1 0	6.0	-22.2	-23.5	-24.8	-22.9	-24.2	-25.5
0 0 1 1 1	7.0	-23.2	-24.5	-25.8	-23.9	-25.2	-26.5
0 1 0 0 0	8.0	-24.2	-25.5	-26.8	-24.9	-26.2	-27.5
0 1 0 0 1	9.0	-25.2	-26.5	-27.8	-25.9	-27.2	-28.5
0 1 0 1 0	10.0	-26.2	-27.5	-28.8	-26.9	-28.2	-29.5
0 1 0 1 1	11.0	-27.2	-28.5	-29.8	-27.9	-29.2	-30.5
0 1 1 0 0	12.0	-28.2	-29.5	-30.8	-28.9	-30.2	-31.5
0 1 1 0 1	13.0	-29.2	-30.5	-31.8	-29.9	-31.2	-32.5
0 1 1 1 0	14.0	-30.2	-31.5	-32.8	-30.9	-32.2	-33.5
0 1 1 1 1	15.0	-31.2	-32.5	-33.8	-31.9	-33.2	-34.5
1 0 0 0 0	16.0	-32.2	-33.5	-34.8	-32.9	-34.2	-35.5
1 0 0 0 1	17.0	-33.2	-34.5	-35.8	-33.9	-35.2	-36.5
1 0 0 1 0	18.0	-34.2	-35.5	-36.8	-34.9	-36.2	-37.5
1 0 0 1 1	19.0	-35.2	-36.5	-37.8	-35.9	-37.2	-38.5
1 0 1 0 0	20.0	-36.2	-37.5	-38.8	-36.9	-38.2	-39.5
1 0 1 0 1	21.0	-37.2	-38.5	-39.8	-37.9	-39.2	-40.5
1 0 1 1 0	22.0	-38.2	-39.5	-40.8	-38.9	-40.2	-41.5
1 0 1 1 1	23.0	-39.2	-40.5	-41.8	-39.9	-41.2	-42.5
1 1 0 0 0	24.0	-40.2	-41.5	-42.8	-40.9	-42.2	-43.5
1 1 0 0 1	25.0	-41.2	-42.5	-43.8	-41.9	-43.2	-44.5
1 1 0 1 0	26.0	-42.2	-43.5	-44.8	-42.9	-44.2	-45.5
1 1 0 1 1	27.0	-43.2	-44.5	-45.8	-43.9	-45.2	-46.5
1 1 1 0 0							
1 1 1 0 1							
1 1 1 1 0							
1 1 1 1 1							

These states should never be used. If sensitivities of this order are required (eg. the Swedish Rural SPM Specification), it is recommended that the Controlled Sensitivity setting is set to 20dB (1 0 1 0 0) and external components selected to set the Input Amp gain to a higher figure.

*Table 2 Controlled Sensitivity Setting Information*

The figures provided in Table 2 assume:

1. The recommended amplifier components (see Figure 2) are employed providing an amplifier gain at 16kHz of 19.8dB  $\pm$ 0.3dB or at 12kHz of 19.1dB  $\pm$ 0.3dB.
2. A comparator sensitivity of 1.6dB(ref.)  $\pm$ 1dB (the variation being due to filter gain error, filter output offset, comparator input offset or a combination of all 3).
3. The applied  $V_{DD}$  is 5.0 volts; 0dB (ref.) = 775mVrms.

# Application Information .....

## Controlled Sensitivity Setting .....

With the external gain (sensitivity) components employed as shown in Figure 2 the gain of the input stages is 19.8dB (12kHz) or 20.5dB (16kHz). For controlled sensitivity setting the gain of each bandpass filter, and hence the device sensitivity, is adjusted by the applied serial bits  $D_1$  to  $D_5$ .

In the Controlled Sensitivity mode the system frequency is selected by bit  $D_0$  ('1' = 12kHz; '0' = 16kHz). Data is loaded Bit 5 ( $D_5$ ) first.

Table 2 details the serial data input to produce the required sensitivity. Minimum, Nominal and Maximum Sensitivity figures are provided to make complete allowance for internal circuit offsets and component tolerances. 0dB(ref.) = 775mVrms at  $V_{DD} = 5.0$  volts; varies directly with  $V_{DD}$ . Examples are provided as a guide to meeting national specifications.

### German FTZ Specification 16kHz

This system has a Must Decode level of -21dB(ref.) and a Must-Not Decode level of -27dB(ref.). Reference to Table 2 shows that Bandpass Filter Gain settings of 5dB, 6dB or 7dB will enable an FX641 channel to meet this level specification.

Figure 6 illustrates the range of these various settings.

Hence to meet the German FTZ specification, the input data ( $D_5$  to  $D_0$ ) can be:

- or **0 0 1 0 1 0** **5.0dB**
- or **0 0 1 1 0 0** **6.0dB**
- or **0 0 1 1 1 0** **7.0dB**

Selecting the middle setting would give the greatest noise immunity.

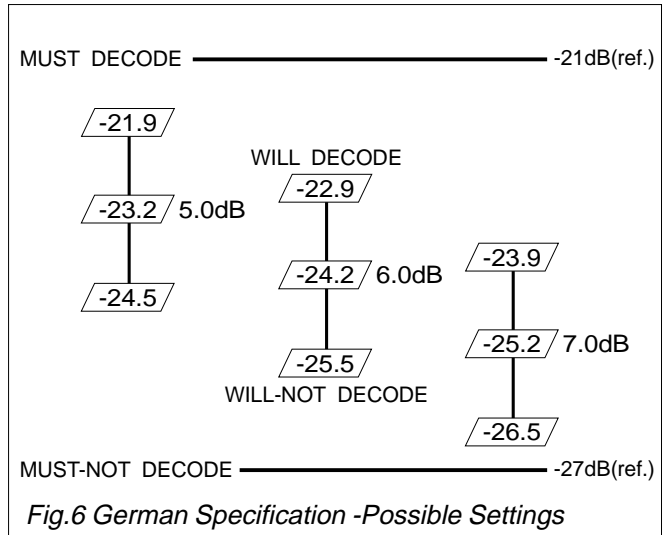

Fig.6 German Specification -Possible Settings

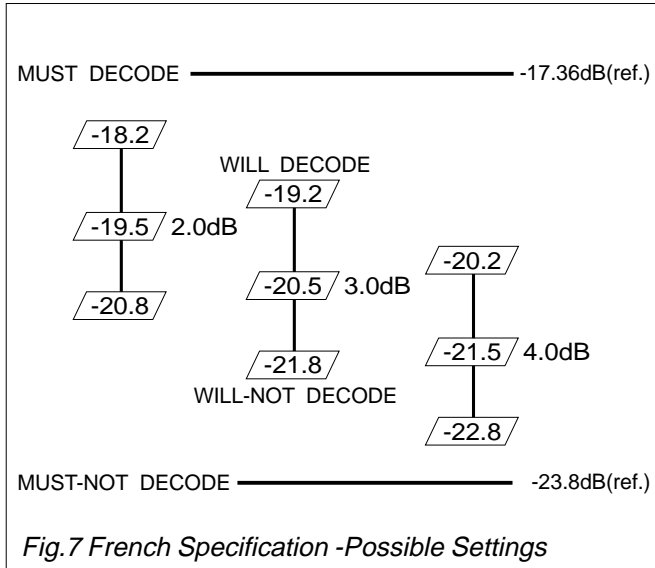

Fig.7 French Specification -Possible Settings

### French Specification 12kHz

This system has a Must Decode level of -17.36dB(ref.) and a Must-Not Decode level of -23.8dB(ref.). Reference to Table 2 shows that Bandpass Filter Gain settings of 2dB, 3dB or 4dB will enable an FX641 channel to meet this level specification.

Fig 7 illustrates the range of these various settings.

Hence to meet the French SPM specification, the input data ( $D_5$  to  $D_0$ ) can be:

- or **0 0 0 1 0 1** **2.0dB**
- or **0 0 0 1 1 1** **3.0dB**
- or **0 0 1 0 0 1** **4.0dB**

Selecting the middle setting would give the greatest noise immunity.

System Select	Preset Level	Output Select	Output Enable	Operating Mode	
X	0	0	0	Packet Mode Output;	Serial Data Control
X	0	1	0	Tone Follower Output;	Serial Data Control
0	1	0	0	Packet Mode Output;	Preset Sensitivity 16kHz
1	1	0	0	Packet Mode Output;	Preset Sensitivity 12kHz
0	1	1	0	Tone Follower Output;	Preset Sensitivity 16kHz
1	1	1	0	Tone Follower Output;	Preset Sensitivity 12kHz
X	X	X	1	Tristate Output	High Z

Table 3 Operating Mode Configurations

X = don't care

# Application Information .....

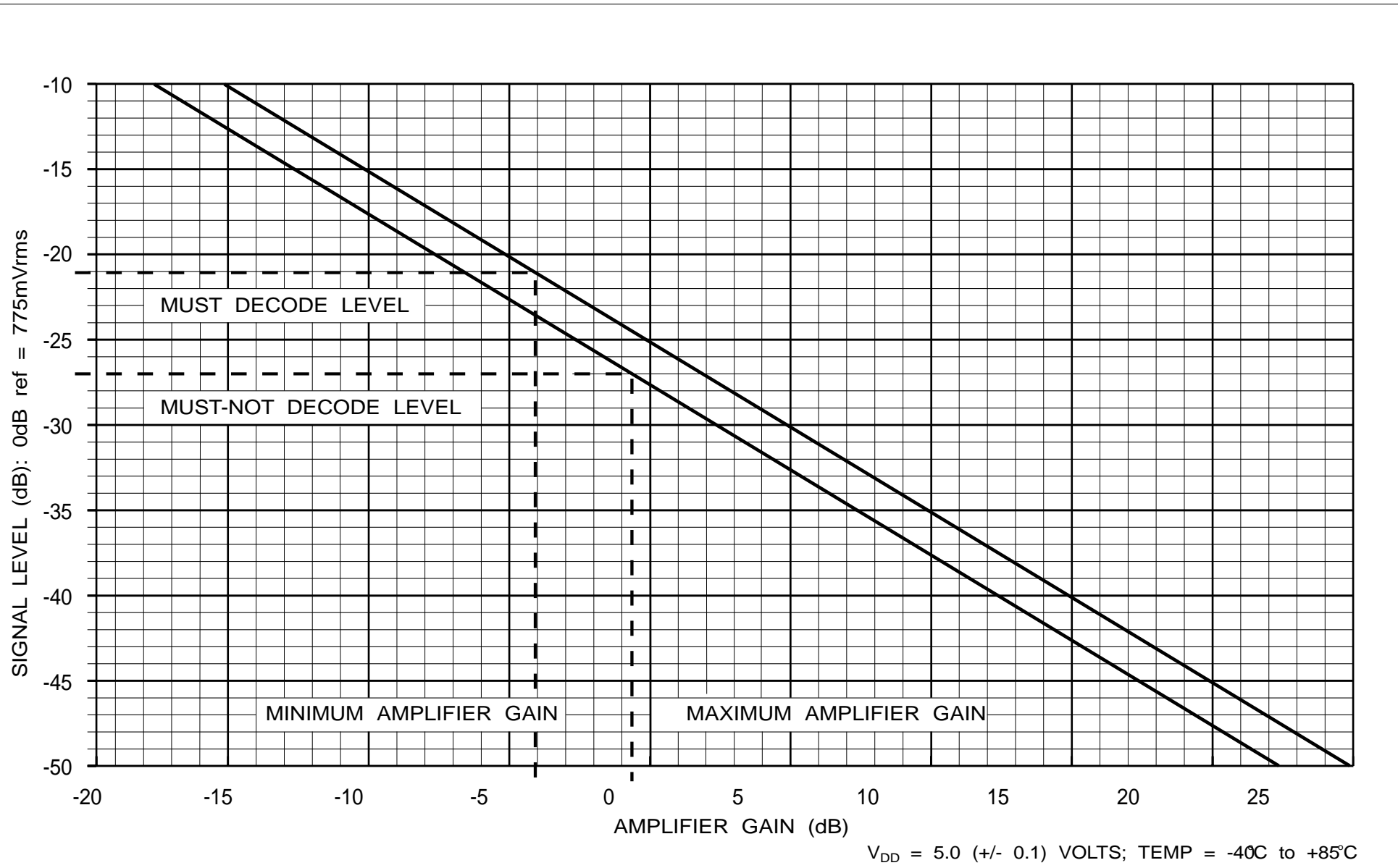

Fig.8 Input Gain Calculation Graph for use in the Fixed Sensitivity Mode

## Application Information .....

### Fixed Sensitivity Setting

In this mode the sensitivity of each channel is set by the correct selection of the components around the Channel Input Amplifier.

Note that the device sensitivity is directly proportional to the applied power supply ( $V_{DD}$ ).

### Input Gain Calculation

The input amplifier, with its external circuitry, is available to set the sensitivity of the FX641 to conform to the user's national level specification with regard to 'Must' and 'Must-Not' decode signal levels.

With reference to the graph in Figure 8, the following steps will assist in the determination of the required gain/attenuation.

#### Step 1

Draw two horizontal lines from the Y-axis (Signal Level (dB)).

The upper line will represent the required 'Must' decode level.

The lower line will represent the required 'Must-Not' decode level.

#### Step 2

Mark the intersection of the upper horizontal line and the upper sloping line; drop a vertical line from this point to the X-axis (Amplifier Gain (dB)).

The point where the vertical line meets the X-axis will indicate the MINIMUM Input Amp gain required for reliable decoding of valid signals.

#### Step 3

Mark the intersection of the lower horizontal line and the lower sloping line; drop a vertical line from this point to the X-axis.

The point where the vertical line meets the X-axis will indicate the MAXIMUM allowable Input Amp gain.

Input signals at or below the 'Must-Not' decode level will not be detected as long as the amplifier gain is no higher than this level.

Select the *Input Gain Components* as described.

### Input Gain Components

With reference to the gain components shown in Figure 2.

The user should calculate and select external components ( $R_1/R_3/C_3$ ,  $R_2/R_4/C_4$  and  $R_5/R_7/C_5$ ,  $R_6/R_8/C_6$ ) to provide amplifier gains within the limits obtained in Steps 2 and 3.

Component tolerances should not move the gain-figure outside these limits. The graph in Figure 8 is for the calculation of input gain components for an FX641 using a  $V_{DD}$  of 5.0 ( $\pm 0.1$ ) volts.

It is recommended that the designed gain is near the centre of the calculated range.

### Microcircuit Protection Against High Voltages

Telephone systems may have high d.c. and a.c. voltages present on the line. If the FX641 is part of a host equipment that has its own signal input protection circuitry, there will be no need for further protection as long as the voltage on any pin is limited to within  $V_{DD} + 0.3V$  and  $V_{SS} - 0.3V$ .

If the host system does not have input protection, or there are signals present outside the device's specified limits, the FX641 will require protection diodes at its signal inputs (+ and -). The breakdown voltage of capacitors and the peak inverse voltage of the diodes must be sufficient to withstand the sum of the d.c. voltages plus all expected signal peaks.

### Aliasing

Due to the switched-capacitor filters employed in the FX641, care should be taken, with the chosen external components, to avoid the effects of alias distortion.

*Possible Alias Frequencies:*

12kHz Mode = 52kHz

16kHz Mode = 69kHz

If these alias frequencies are liable to cause problems and/or interference, it is recommended that anti-alias capacitors are employed across input resistors  $R_3$  and  $R_4$  or  $R_7$  and  $R_8$ .

Values of anti-alias capacitors should be chosen so as to provide a highpass cutoff frequency, in conjunction with  $R_3$  ( $R_4$ ) ( $R_7$ ) ( $R_8$ ), of approximately 20kHz to 25kHz (12kHz system) or 25kHz to 30kHz (16kHz system).

$$\text{i.e. } C = \frac{1}{2 \times \pi \times f_0 \times R_3}$$

When anti-alias capacitors are used, allowance must be made for reduced gain at the SPM frequency (12kHz or 16kHz).

## Specification

### Absolute Maximum Ratings

Exceeding the maximum rating can result in device damage. Operation of the device outside the operating limits is not implied.

Supply voltage		-0.3 to 7.0V
Input voltage at any pin (ref $V_{SS} = 0V$ )		-0.3 to ( $V_{DD} + 0.3V$ )
Sink/source current (supply pins)		+/- 30mA
(other pins)		+/- 20mA
Total device dissipation @ $T_{AMB} 25^{\circ}C$		800mW Max.
Derating		10mW/ $^{\circ}C$
Operating Temperature ( $T_{OP}$ ):	<b>FX641D2/P4</b>	-40 $^{\circ}C$ to +85 $^{\circ}C$
Storage Temperature range ( $T_{ST}$ ):	<b>FX641D2/P4</b>	-40 $^{\circ}C$ to +85 $^{\circ}C$

### Operating Limits

Correct operation of the device outside these limits is not implied.

Parameter	Min.	Max.	Unit
Supply Voltage ( $V_{DD}$ )	4.5	5.5	V
Operating Temperature ( $T_{OP}$ )	-40.0	+85.0	$^{\circ}C$
Xtal/Clock/Clock In Frequency	3.558918	3.589368	MHz

### Operating Characteristics

All device characteristics are measured under the following conditions unless otherwise specified:

$V_{DD} = 5.0V$   $T_{AMB} = -40^{\circ}C$  to  $+85^{\circ}C$ . Audio Level 0dB(ref.): = 775mVrms. Noise Bandwidth = 50kHz.

Xtal/Clock or 'Clock In' Frequency = 3.579545MHz. System Setting = 12kHz or 16kHz.

Characteristics	See Note	Min.	Typ.	Max.	Unit
Supply Current		-	2.0	5.0	mA
<b>Input/Output Parameters</b>					
Clock Out Load		-	-	15.0	pF
<b>Logic Inputs</b>					
Input Logic '1' (High)		3.5	-	-	V
Input Logic '0' (Low)		-	-	1.5	V
Input Leakage Current ( $V_{IN} = 0$ to $V_{DD}$ )	13	-5.0	-	5.0	$\mu A$
Input Current ( $V_{IN} = 0$ )	14	-15.0	-	-	$\mu A$
<b>Channel Outputs</b>					
Output Logic '1' ( $I_{OH} = 120\mu A$ ) (Enabled)	1	4.6	-	-	V
Output Logic '0' ( $I_{OL} = 360\mu A$ ) (Enabled)	1	-	-	0.4	V
Output Leakage Current (High-Z Output)	2	-5.0	-	5.0	$\mu A$
<b>Input Amplifier</b>					
D. C. Gain		60.0	-	-	dB
Bandwidth (-3dB)		-	100	-	Hz
Input Impedance		1.0	-	-	M $\Omega$
<b>Overall Performance</b>					
12kHz Detect Bandwidth	3	11.82	-	12.18	kHz
12kHz Not-Detect Frequencies (below 12kHz)	3	-	-	11.52	kHz
12kHz Not-Detect Frequencies (above 12kHz)	3	12.48	-	-	kHz
16kHz Detect Bandwidth	3	15.76	-	16.24	kHz
16kHz Not-Detect Frequencies (below 16kHz)	3	-	-	15.36	kHz
16kHz Not-Detect Frequencies (above 16kHz)	3	16.64	-	-	kHz
<b>Level Sensitivity</b>					
Controlled Sensitivity Mode	3, 4, 12, 15	2.6	1.6	0.6	dB(ref.)
Preset Sensitivity Mode	3, 4, 5, 16	-25.4	-26.4	-27.4	dB(ref.)
<b>Signal Quality Requirements for Correct Operation</b>					
Signal-to-Noise (Amp Input)	4, 8, 9, 10	22.0	20.0	-	dB
Signal-to-Voice (Amp Input)	4, 8, 9, 11	-36.0	-40.0	-	dB
Signal-to-Voice (Amp Output)	4, 8, 10, 11	-1.0	-	-27.0	dB

Continued on next page .....

# Specification .....

Characteristics	See Note	Min.	Typ.	Max.	Unit
Channel Outputs (Ch1 and Ch2) Figure 5					
Mode Change Time	6	-	-	500	ns
Tone Follower Mode (Table 3)					
Response and De-Response Time	3, 4, 7	-	-	10.0	ms
Packet Mode (Table 3)					
Response and De-Response Time	3, 4, 7	40.0	-	48.0	ms

**Notes**

1. Tone Follower or Packet mode enabled; see Table 3.
2. Tristate selected; see Table 3.
3. With adherence to Signal-to-Voice and Signal-to Noise specifications.
4. 12kHz and/or 16kHz system.
5. With Input Amp gain setting = 0dB.
6. Time taken to change between any two of the operational modes: Tone Follower, Packet or Tristate, and with a maximum capacitive load of 30pF on an output.
7. The time delay, after a valid serial data load (or after device powerup), before the condition of the outputs can be guaranteed correct.
8. Immunity to false responses and/or de-responses.
9. Common Mode SPM and balanced voice input signal.
10. With SPM and voice signal amplitudes balanced; to avoid false de-responses due to saturation, the peak-to-peak voice + noise level at the output of the Input Amp should be no greater than the dynamic range of the device. For this reason, the signal-to-voice figure at the Am[ Output will vary with the sensitivity setting. The lowest signal-to-voice figure occurs at the highest sensitivity setting (Table 2, 27dB).
11. Maximum voice frequencies = 3.4kHz.
12. With the Input Amplifier gain at 0dB and the Bandpass Filter gain set at 0dB (Table 2); subtract 1.0dB from this specification for each extra single dB of Bandpass Filter gain programmed. Alternatively, with the input components as recommended in Figure 2, the sensitivity is as defined in Table 2.
13. Logic inputs with no internal pullup; Chip Select, Serial Data, Serial Clock, Output Enable, Output Select and Clock In pins.
14. Logic inputs with an internal pullup; Preset Level and System Select pins.
15. Preset Level= '0', System Select = don't care; Chip Select, Serial Clock and Serial Data inputs active; see Table 3.
16. Preset Level = '1', System Select = input active; Chip Select, Serial Clock and Serial Data inputs inactive; see Table 3.

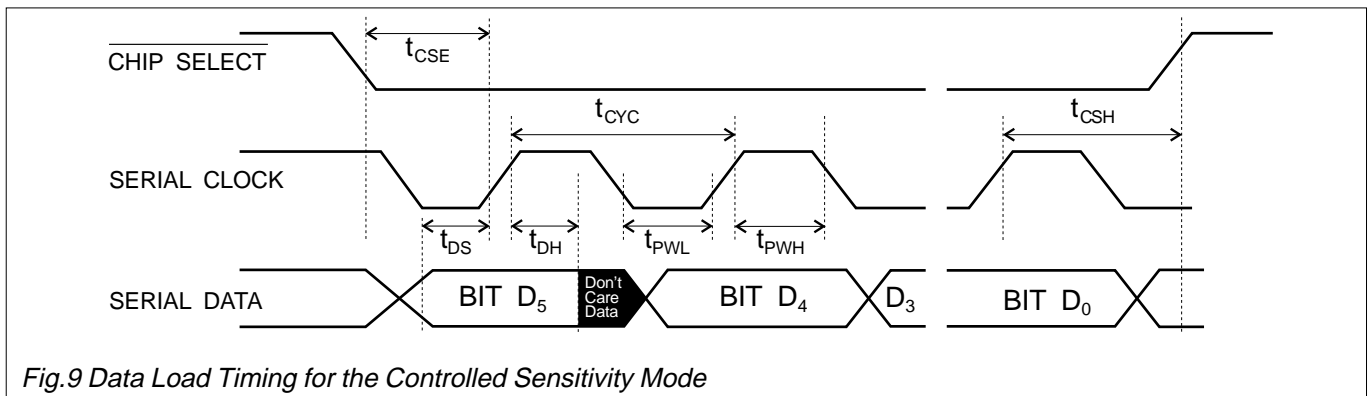

Fig.9 Data Load Timing for the Controlled Sensitivity Mode

Parameter		Min.	Typ.	Max.	Unit
$t_{PWH}$	Serial Clock 'High' Pulse Width	250	-	-	ns
$t_{PWL}$	Serial Clock 'Low' Pulse Width	250	-	-	ns
$t_{CYC}$	Serial Clock Period	600	-	-	ns
$t_{CSE}$	Chip Select 'Low' to Clock 'High' Edge	450	-	-	ns
$t_{DH}$	Data Hold Time	50.0	-	-	ns
$t_{DS}$	Data Setup Time	250	-	-	ns
$t_{CSH}$	Chip Select 'High' from:				
	Clock 'High' Edge	50.0	-	-	ns
	Clock 'High' Edge	-	-	1	serial clock period

## Package Outlines

The FX641 is available in the package styles outlined below. Mechanical package diagrams and specifications are detailed in Section 10 of this document.

Pin 1 identification marking is shown on the relevant diagram and pins on all package styles number anti-clockwise when viewed from the top.

## Handling Precautions

The FX641 is a CMOS LSI circuit which includes input protection. However precautions should be taken to prevent static discharges which may cause damage.

### FX641D2 24-pin plastic S.O.I.C.

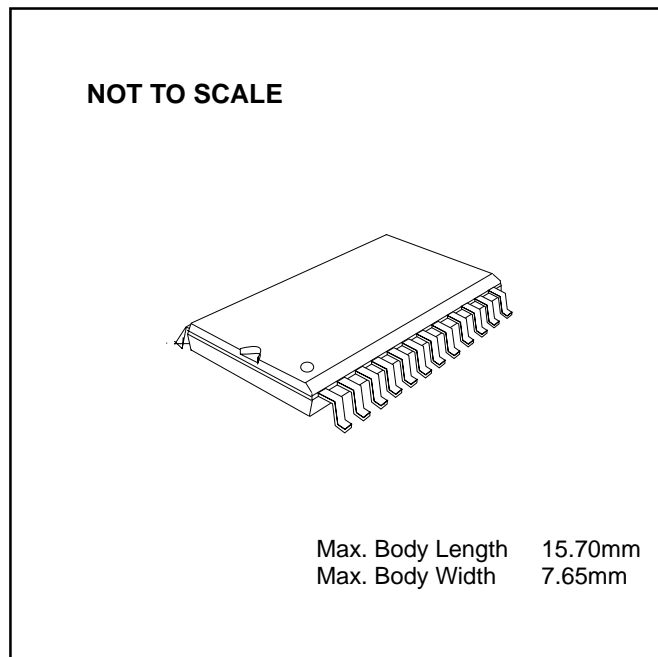

### FX641P4 24-pin plastic DIL

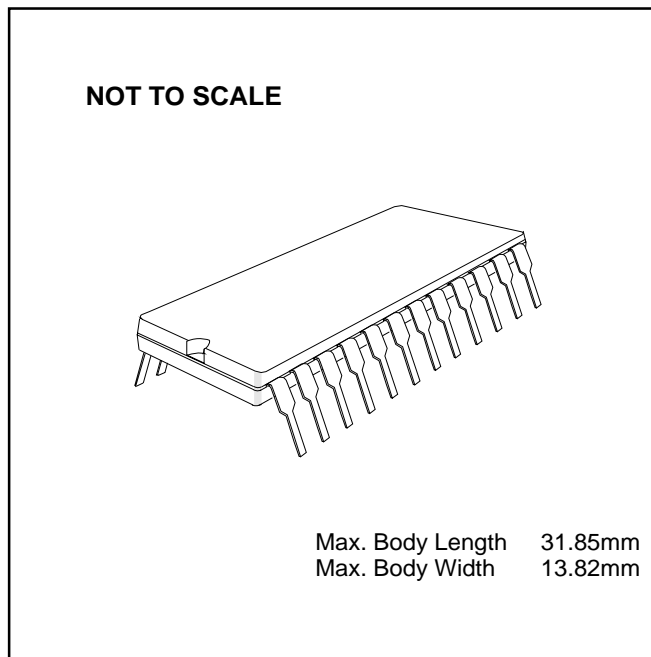

## Ordering Information

**FX641D2** 24-pin plastic S.O.I.C.

**FX641P4** 24-pin plastic DIL



**CML Microcircuits**

COMMUNICATION SEMICONDUCTORS

## CML Product Data

In the process of creating a more global image, the three standard product semiconductor companies of CML Microsystems Plc (*Consumer Microcircuits Limited (UK)*, *MX-COM, Inc (USA)* and *CML Microcircuits (Singapore) Pte Ltd*) have undergone name changes and, whilst maintaining their separate new names (*CML Microcircuits (UK) Ltd*, *CML Microcircuits (USA) Inc* and *CML Microcircuits (Singapore) Pte Ltd*), now operate under the single title **CML Microcircuits**.

These companies are all 100% owned operating companies of the CML Microsystems Plc Group and these changes are purely changes of name and do not change any underlying legal entities and hence will have no effect on any agreements or contacts currently in force.

### CML Microcircuits Product Prefix Codes

Until the latter part of 1996, the differentiator between products manufactured and sold from MXCOM, Inc. and Consumer Microcircuits Limited were denoted by the prefixes MX and FX respectively. These products use the same silicon etc. and today still carry the same prefixes. In the latter part of 1996, both companies adopted the common prefix: CMX.

This notification is relevant product information to which it is attached.

Company contact information is as below:



**CML Microcircuits  
(UK) Ltd**

COMMUNICATION SEMICONDUCTORS

Oval Park, Langford, Maldon,  
Essex, CM9 6WG, England  
Tel: +44 (0)1621 875500  
Fax: +44 (0)1621 875600  
uk.sales@cmlmicro.com  
www.cmlmicro.com



**CML Microcircuits  
(USA) Inc.**

COMMUNICATION SEMICONDUCTORS

4800 Bethania Station Road,  
Winston-Salem, NC 27105, USA  
Tel: +1 336 744 5050,  
0800 638 5577  
Fax: +1 336 744 5054  
us.sales@cmlmicro.com  
www.cmlmicro.com



**CML Microcircuits  
(Singapore) Pte Ltd**

COMMUNICATION SEMICONDUCTORS

No 2 Kallang Pudding Road, 09-05/  
06 Mactech Industrial Building,  
Singapore 349307  
Tel: +65 7450426  
Fax: +65 7452917  
sg.sales@cmlmicro.com  
www.cmlmicro.com

This datasheet has been downloaded from:

[www.DatasheetCatalog.com](http://www.DatasheetCatalog.com)

Datasheets for electronic components.



LittleDiode supplies new, hard to find or obsolete electronic components and semiconductors all over the world.

With over two million different components listed you are sure to find the part you need.

Feel free to visit us today at our online store:

[LittleDiode.com](http://LittleDiode.com)

Looking forward to providing you with the best possible service.