

FY8AAJ-03F

HIGH-SPEED SWITCHING USE

FY8AAJ-03F



- 4V DRIVE
- V_{DSS} 30V
- $r_{DS(ON)}(MAX)$ 28mΩ
- I_D 8A

OUTLINE DRAWING Dimensions in mm

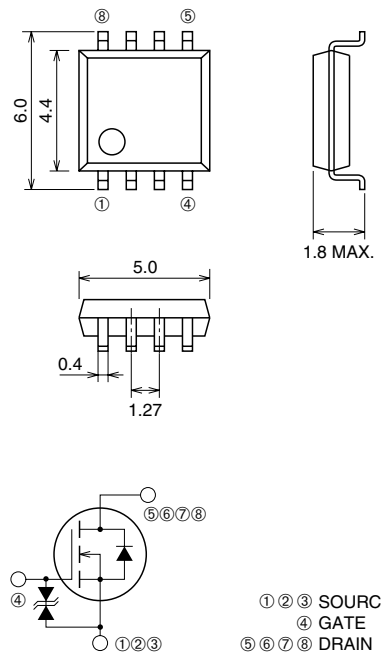

① ② ③ SOURCE
④ GATE
⑤ ⑥ ⑦ ⑧ DRAIN

SOP-8

APPLICATION

Motor control, Lamp control, Solenoid control
DC-DC converter, etc.

MAXIMUM RATINGS ($T_c = 25^\circ C$)

| Symbol | Parameter | Conditions | Ratings | Unit |
|-----------|----------------------------------|---------------|----------|------------|
| V_{DSS} | Drain-source voltage | $V_{GS} = 0V$ | 30 | V |
| V_{GSS} | Gate-source voltage | $V_{DS} = 0V$ | ± 20 | V |
| I_D | Drain current | | 8 | A |
| I_{DM} | Drain current (Pulsed) | | 56 | A |
| I_{DA} | Avalanche drain current (Pulsed) | $L = 10\mu H$ | 8 | A |
| I_S | Source current | | 1.5 | A |
| I_{SM} | Source current (Pulsed) | | 6.0 | A |
| P_D | Maximum power dissipation | | 1.7 | W |
| T_{ch} | Channel temperature | | -55~+150 | $^\circ C$ |
| T_{stg} | Storage temperature | | -55~+150 | $^\circ C$ |
| — | Weight | Typical value | 0.07 | g |

ELECTRICAL CHARACTERISTICS (Tch = 25°C)

| Symbol | Parameter | Test conditions | Limits | | | Unit |
|------------|----------------------------------|---|--------|-------|-------|------|
| | | | Min. | Typ. | Max. | |
| V (BR)DSS | Drain-source breakdown voltage | ID = 1mA, VGS = 0V | 30 | — | — | V |
| V (BR)GSS | Gate-source breakdown voltage | IG = ±100μA, VGS = 0V | ±20 | — | — | V |
| IDSS | Drain-source leakage current | VDS = 30V, VGS = 0V | — | — | 0.1 | mA |
| IGSS | Gate-source leakage current | VGS = ±20V, VDS = 0V | — | — | ±10 | μA |
| VGS (th) | Gate-source threshold voltage | ID = 1mA, VDS = 10V | 1.0 | 1.5 | 2.0 | V |
| rDS (ON) | Drain-source on-state resistance | ID = 8A, VGS = 10V | — | 22 | 28 | mΩ |
| rDS (ON) | Drain-source on-state resistance | ID = 4A, VGS = 4.5V | — | 31 | 43 | mΩ |
| rDS (ON) | Drain-source on-state resistance | ID = 4A, VGS = 4V | — | 35 | 50 | mΩ |
| VDS (ON) | Drain-source on-state voltage | ID = 8A, VGS = 10V | — | 0.176 | 0.224 | V |
| yfs | Forward transfer admittance | ID = 8A, VDS = 10V | — | 13 | — | S |
| Ciss | Input capacitance | VDS = 10V, VGS = 0V, f = 1MHz | — | 600 | — | pF |
| Coss | Output capacitance | | — | 200 | — | pF |
| Crss | Reverse transfer capacitance | | — | 90 | — | pF |
| td (on) | Turn-on delay time | VDD = 15V, ID = 4A, VGS = 10V, RG = 50Ω | — | 12 | — | ns |
| tr | Rise time | | — | 16 | — | ns |
| td (off) | Turn-off delay time | | — | 30 | — | ns |
| tf | Fall time | | — | 6.5 | — | ns |
| Qg | Total gate charge | VDD = 15V, VGS = 10V, ID = 8A | — | 13.8 | — | nC |
| Qgs | Gate-source charge | | — | 1.6 | — | nC |
| Qgd | Gate-drain charge | | — | 3.5 | — | nC |
| VSD | Source-drain voltage | IS = 1.5A, VGS = 0V | — | 0.75 | 1.10 | V |
| Rth (ch-a) | Thermal resistance | Channel to air | — | — | 73.5 | °C/W |
| trr | Reverse recovery time | IS = 1.5A, dis/dt = -50A/μs | — | 50 | — | ns |



LittleDiode supplies new, hard to find or obsolete electronic components and semiconductors all over the world.

With over two million different components listed you are sure to find the part you need.

Feel free to visit us today at our online store:

LittleDiode.com

Looking forward to providing you with the best possible service.