

FEATURES

- adjustable clamp level from -5.5 V to +5.5 V at ± 10 V supplies.
- ultra low differential gain (0.02% typ.) and differential phase (0.03° typ.)
- wideband unity gain: **GB4550** ± 0.2 dB at 25 MHz
GB4550A ± 0.1 dB at 25 MHz
- both drive 150pF loads at full power, flat to 10 MHz.
- **GB4550A** — tight delay spread of $\pm 0.15^\circ$ at colorburst.
- convenient 8 pin SIP packaging.
- both can be configured as a gain stage with reduced bandwidth.

PIN CONNECTIONS

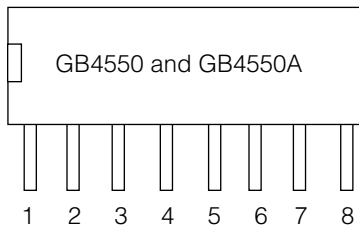

Pin No.	GB4550	GB4550A	Function
1	+IN	+IN	non-inverting input
2	V _{CC}	V _{CC}	positive power supply
3	COMP	NC	frequency compensation or NC
4	V _{CL}	V _{CL}	clamp voltage input
5	C _X	C _X	external capacitor
6	V _{EE}	V _{EE}	negative power supply
7	-IN	-IN	inverting input
8	OUT	OUT	output

ORDERING INFORMATION

Part Number	Package Type	Temperature Range
GB4550 - CSA	8 pin SIP	0 to 70°C
GB4550ACSA	8 pin SIP	0 to 70°C

DESCRIPTION

The GB4550 and GB4550A are high performance monolithic video buffer/clamps made on Gennum's LSI process. They feature a wideband differential amplifier that can be configured as a gain stage. The output signal voltage is limited to +2V above the clamp level in order to prevent damage to crosspoints connected to the output.

The clamping level can be set for normal sync tip clamping by connecting pin 4 to -0.286 volts. For other applications, the clamping voltage level can be varied from -5.5 to +5.5 volts.

The GB4550A features a tight delay spread of only ± 0.15 degrees while the GB4550 maintains a ± 1.5 degree delay spread. Both devices operate from ± 9 to ± 12 V power supplies and will directly interface with Gennum's video crosspoint switches.

The 8 pin SIP package is ideally suited for space restricted board layouts.

APPLICATIONS

- Input buffering and clamping to crosspoint switches
- Inter - system video signal clamping

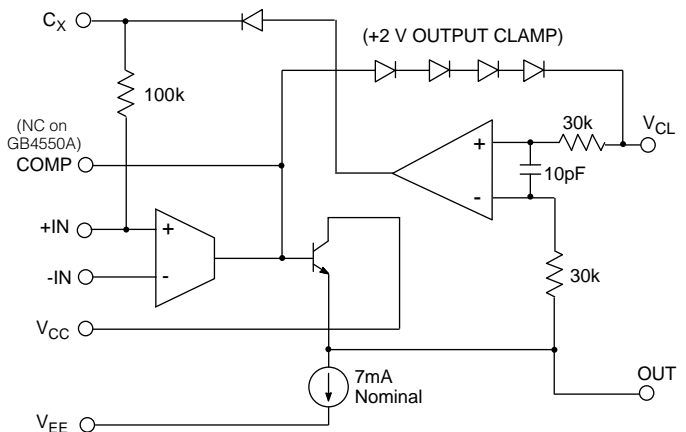

All resistors in ohms, all capacitors in microfarads unless otherwise stated

SIMPLIFIED CIRCUIT DIAGRAM

ABSOLUTE MAXIMUM RATINGS

PARAMETER	VALUE
Supply Voltage V_S	± 13.5 V
Operating Temperature Range	$0^\circ\text{C} \leq T_A \leq 70^\circ\text{C}$
Storage Temperature Range	$-65^\circ\text{C} \leq T_S \leq 150^\circ\text{C}$
Lead Temperature (Soldering, 10 Sec)	260°C
Differential Video Input Voltage	± 5 V
Clamp Input Voltage	$V_{EE} + 2.5\text{ V} \leq V_{CL} \leq V_{CC} - 2.5\text{ V}$

CAUTION
ELECTROSTATIC
SENSITIVE DEVICES
DO NOT OPEN PACKAGES OR HANDLE
EXCEPT AT A STATIC-FREE WORKSTATION



ELECTRICAL CHARACTERISTICS $V_S = \pm 10$ V, $T_A = 0 - 70^\circ\text{C}$, $R_L = 10\text{k}\Omega$, $C_L = 150$ pF, $C_{COMP} = 0$ pF unless otherwise shown.

	PARAMETER	SYMBOL	CONDITIONS	MIN	TYP	MAX	UNITS
POWER SUPPLIES	Supply Voltage	V_S	Operating Range	± 9	± 10	± 12	V
	+ Supply Current	I+		-	9	13.8	mA
	- Supply Current	I-		-	9	13.8	mA
SIGNAL PATH	Maximum Input Voltage Above V_{CL}	$V_{IN\ MAX}$		1.8	2.0	2.25	V
	Insertion Loss	I.L.	$f = 100\text{kHz}$	-	-	0.03	dB
GB4550 SIGNAL PATH	Full Power Bandwidth	FPBW	-3.0dB, $V_{IN} = 1\text{V p-p}$	15	18	-	MHz
	Small Signal Bandwidth	SSBW	$\pm 0.2\text{dB}$, $V_{IN} = 100\text{mV p-p}$	20	25	-	MHz
	Frequency Response		at 10MHz, $V_{IN} = 1\text{V p-p}$	-	0.05	-	dB
	Signal Path Delay	θ_D	at 3.58MHz	-	-8	-	deg
	Delay Tolerance		at 3.58MHz	-	± 1.5	-	deg
GB4550A SIGNAL PATH	Full Power Bandwidth	FPBW	-3.0dB, $V_{IN} = 1\text{V p-p}$	17	20	-	MHz
	Small Signal Bandwidth	SSBW	$\pm 0.1\text{dB}$, $V_{IN} = 100\text{mV p-p}$, $C_L = 100\text{pF}$	25	30	-	MHz
	Frequency Response		at 10MHz, $V_{IN} = 1\text{V p-p}$	-	0.1	-	dB
	Signal Path Delay	θ_D	at 3.58 MHz	-	-7.5	-	deg
	Delay Tolerance		at 3.58MHz	-	± 0.15	-	deg
SIGNAL PATH	Differential Gain	dg	at 3.58MHz	-	0.02	0.05	%
	Differential Phase	dp	at 3.58MHz	-	0.03	0.05	deg
	Input Resistance	R_{IN}		80	100	-	k Ω
	Input Capacitance	C_{IN}		-	2.0	-	pF
	Output Resistance	R_{OUT}	$A_V = +1, f = 0$ to 10MHz $A_V = +1, f = 100\text{MHz}$	- -	8.6 53	- -	Ω Ω
CLAMP	Clamp Voltage Range	V_{CL}		-5.5	-	+5.5	V
	Clamp Accuracy		$V_{IN} = 1\text{V p-p}$	-	7	28	mV

DETAILED DESCRIPTION

The GB4550(A) is intended for video applications requiring coarse DC restoration coupled with flat frequency response. As shown in Figure 1, the signal path features a wide band operational amplifier designed to be unity gain stable. While this amplifier is not intended to drive $75\ \Omega$ transmission lines, it is ideal for applications where high capacitive loads, up to several hundred picofarads, must be driven, such as input buffering and DC restoration of video signals.

Optimal frequency response for the GB4550(A) occurs with load capacitances in the range of 80 pF to 100 pF as shown in Figure 4. For smaller loads, an external capacitor can be added to extend the bandwidth and improve the flatness of the device response.

The clamping function is achieved through the use of a simple comparator. The inverting input of the comparator is connected to the GB4550(A) output, while the non-inverting input is connected to the clamp voltage reference. For output signal voltages more positive than the clamp reference the comparator output is essentially open-circuit, while signal voltages more negative than the clamp reference result in the charging of C_x . The action of the comparator is to provide a positive current which is fed back to the op-amp non-inverting input under conditions where the op-amp output is more negative than the clamp reference voltage. This negative feedback raises the DC level of the input signal to the point where all signal fluctuations occur at voltages above the clamp reference level. This is the desired clamp action.

The input to the op-amp must be AC coupled using an appropriate size of capacitor, which then acts as a DC "reservoir" for the corrective level shift.

Under equilibrium conditions the average current supplied by the comparator output is just sufficient to balance the current discharging the input capacitor. This discharge current is simply the input bias current of the op-amp, typically less than $20\ \mu\text{A}$. However, an external resistor can be added to increase the pull down current. Under dynamic conditions, where the system is adjusting for a change in the signal level, the charging current may be in the milliamp range. Because the corrective current is small under equilibrium conditions, the error voltage at the comparator input is small also, so clamping accuracy to within $\pm 7\ \text{mV}$ is achievable.

The clamp circuit makes use of a "peak hold" capacitor, C_x , at the output of the comparator. This gives rise to a more constant voltage at the comparator output which is translated to a more constant corrective current by an internal $100\ \text{k}\Omega$ resistor connected between the comparator output and the signal input.

To avoid excessive phase shift and consequent instability of the clamp feedback loop, the peak hold capacitor needs to be considerably smaller (e.g. 1000 times) than the input coupling capacitor. If a faster clamp is desirable (e.g. for 60 Hz hum elimination) the peak hold capacitor can be removed and a smaller input coupling capacitor employed. In this application some distortion of the signal "tip" is unavoidable.

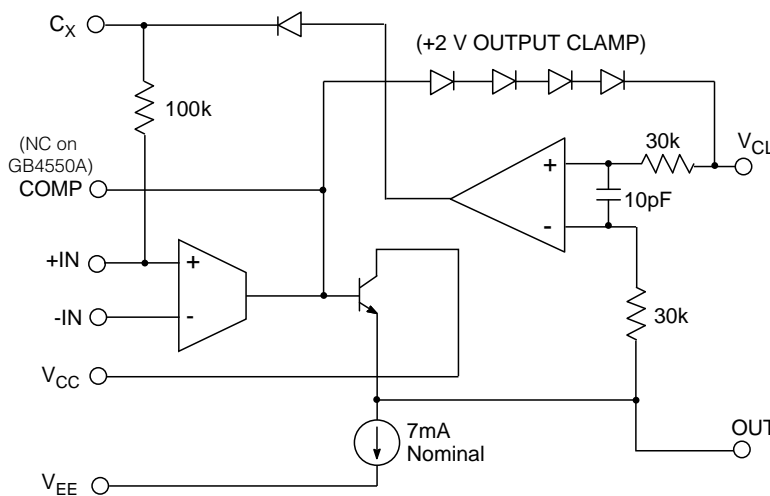

All resistors in ohms, all capacitors in microfarads unless otherwise stated.

Fig. 1 Simplified Circuit Diagram

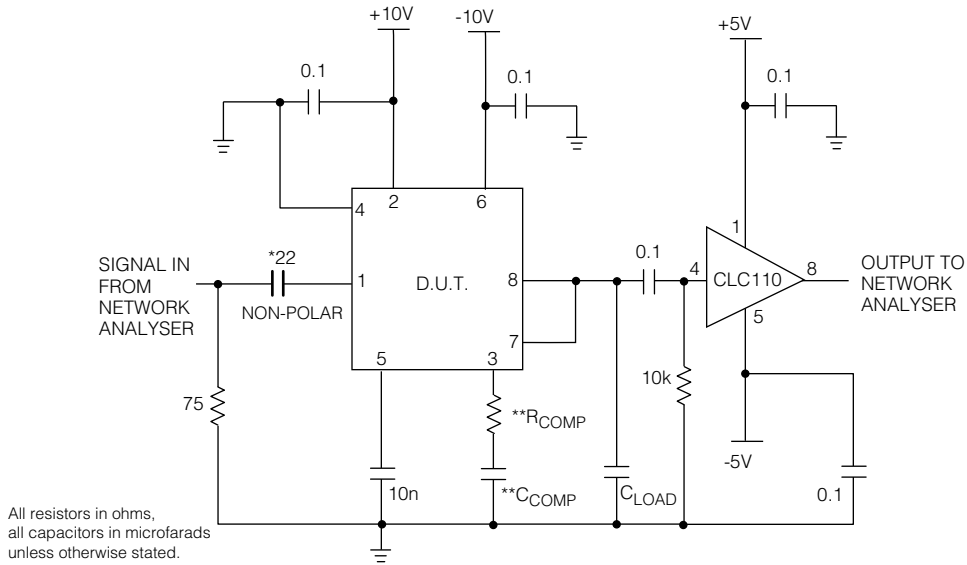

NOTES: This circuit can be used for Frequency Response, Delay and Differential Gain and Phase measurements.

* This input capacitor must be shorted out when performing Differential Gain and Phase tests.

** R_{COMP} and C_{COMP} are only used on GB4550.

Fig. 2 Test Circuit

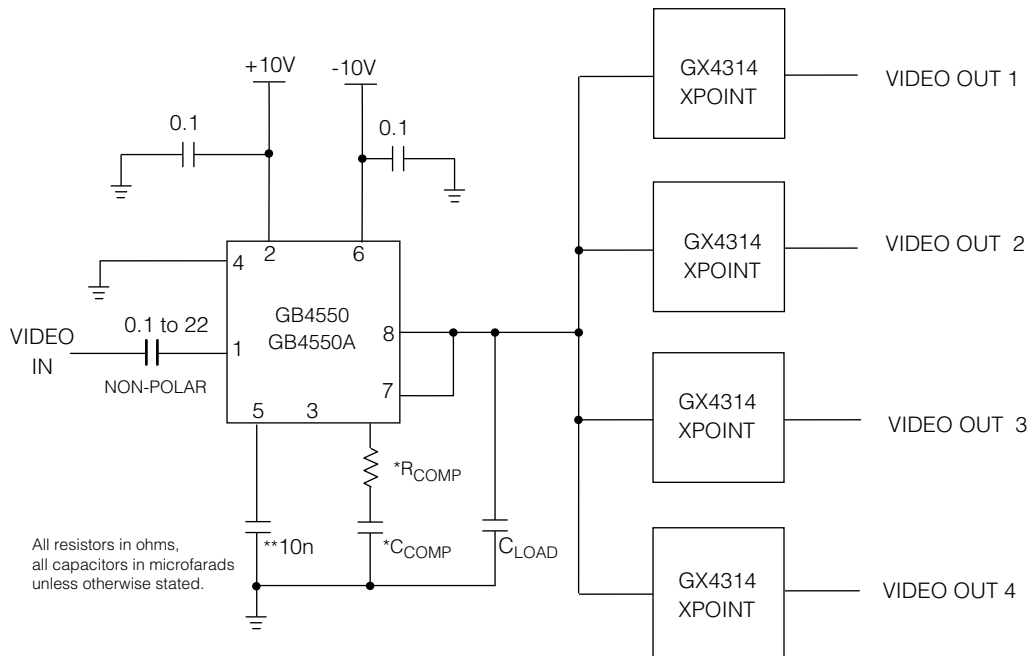

NOTES: In most applications R_{COMP} and C_{COMP} will not be needed since the bandwidth depends on the bus capacitance.

In general, the maximum occurs when C_{LOAD} is between 82 pF and 100 pF.

They are used to control the roll-off for higher load conditions.

* Not used on GB4550A.

** The value of this capacitor should be proportional to the input capacitor used.
The value shown is for a 22 μ F input capacitor.

Fig. 3 Typical Application Circuit

TYPICAL PERFORMANCE CURVES

Unless otherwise shown $V_{IN} = \pm 10V$

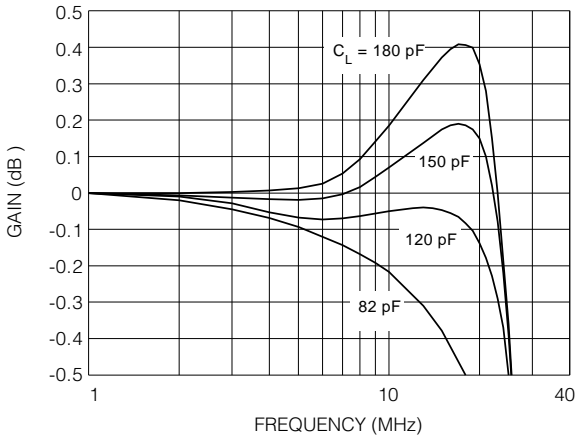

Fig. 4 GB4550 Frequency Response

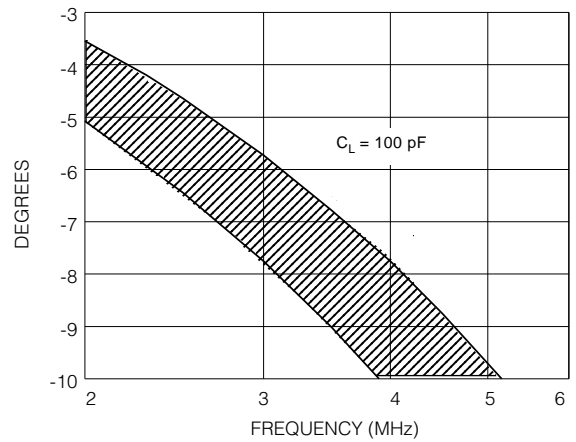

Fig. 5 GB4550 Phase Delay Spread

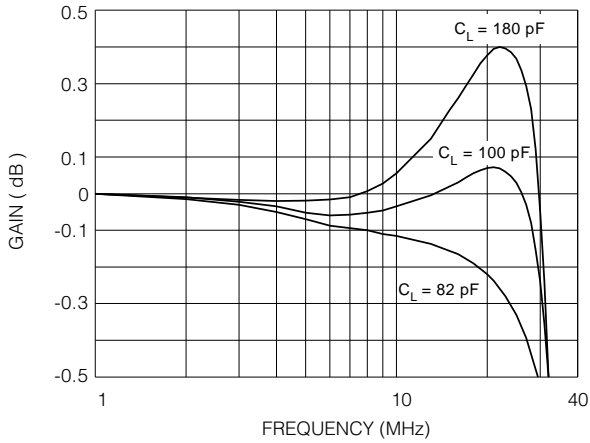

Fig. 6 GB4550A Frequency Response

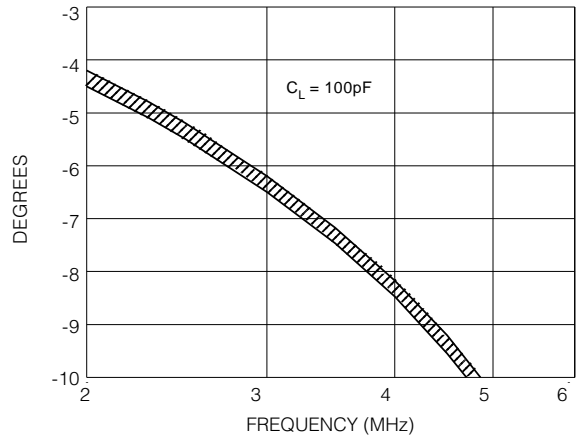

Fig. 7 GB4550A Phase Delay Spread

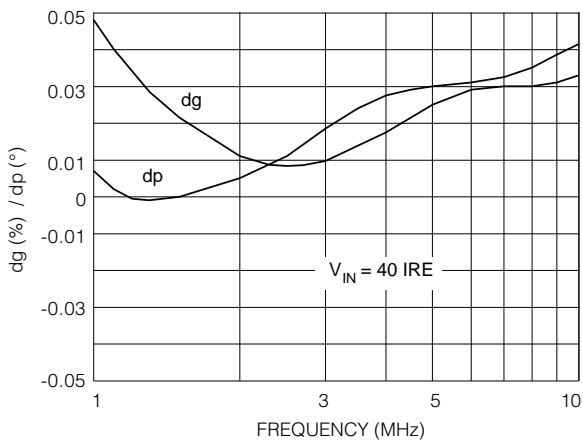

Fig. 8 Differential Gain and Phase

REVISION NOTE: Detailed Description added

DOCUMENT IDENTIFICATION

PRODUCT PROPOSAL

This data has been compiled for market investigation purposes only, and does not constitute an offer for sale.

ADVANCE INFORMATION NOTE

This product is in development phase and specifications are subject to change without notice. Gennum reserves the right to remove the product at any time. Listing the product does not constitute an offer for sale.

PRELIMINARY DATA SHEET

The product is in a preproduction phase and specifications are subject to change without notice.

DATA SHEET

The product is in production. Gennum reserves the right to make changes at any time to improve reliability, function or design, in order to provide the best product possible.



LittleDiode supplies new, hard to find or obsolete electronic components and semiconductors all over the world.

With over two million different components listed you are sure to find the part you need.

Feel free to visit us today at our online store:

LittleDiode.com

Looking forward to providing you with the best possible service.