

**FEATURES**

- highly optimized & flexible architecture for multirate FIR filtering applications
- implements dual 12 tap filters operating at 40 MHz or single 23 or 24 tap filter operating at 20 MHz maximum data rate
- stores up to 108 fully-programmable 12 tap filters with 12 bit coefficients at each tap, dynamically addressable in each clock cycle
- 3 flexible memory loading modes
- 20 bit pipeline for cascading up to 3 devices
- 20 bit output accumulator
- filter output negate and zero controls
- supports both symmetrical and asymmetrical FIR filters
- 40 MHz maximum computation and input/output data rates

**APPLICATIONS**

Video rate conversion; High performance FIR filters; Adaptive digital filters; Video encoding; Digital modulation

**DESCRIPTION**

The GF9101 is a high performance multirate digital filter which can be programmed to implement a wide range of signal processing functions using both symmetrical and asymmetrical filter structures. It is composed of a 12-tap FIR filter with internal RAM to hold up to 108 individual filters. An externally controlled address bus selects one of the 108 filters in each clock cycle. Pipelined architecture allows cascading of up to three devices with no additional hardware.

Two 10-bit input shift registers are provided for multiplexed filtering applications. The 12-bit coefficients can be programmed in serial, high speed parallel or microprocessor modes. In the high speed parallel mode, any one of the 108 filters can be reprogrammed in 18 clock cycles.

**ORDERING INFORMATION**

| PART NUMBER  | PACKAGE            | TEMPERATURE |
|--------------|--------------------|-------------|
| GF9101 - CMQ | 160 pin Metal Quad | 0° to 70°C  |

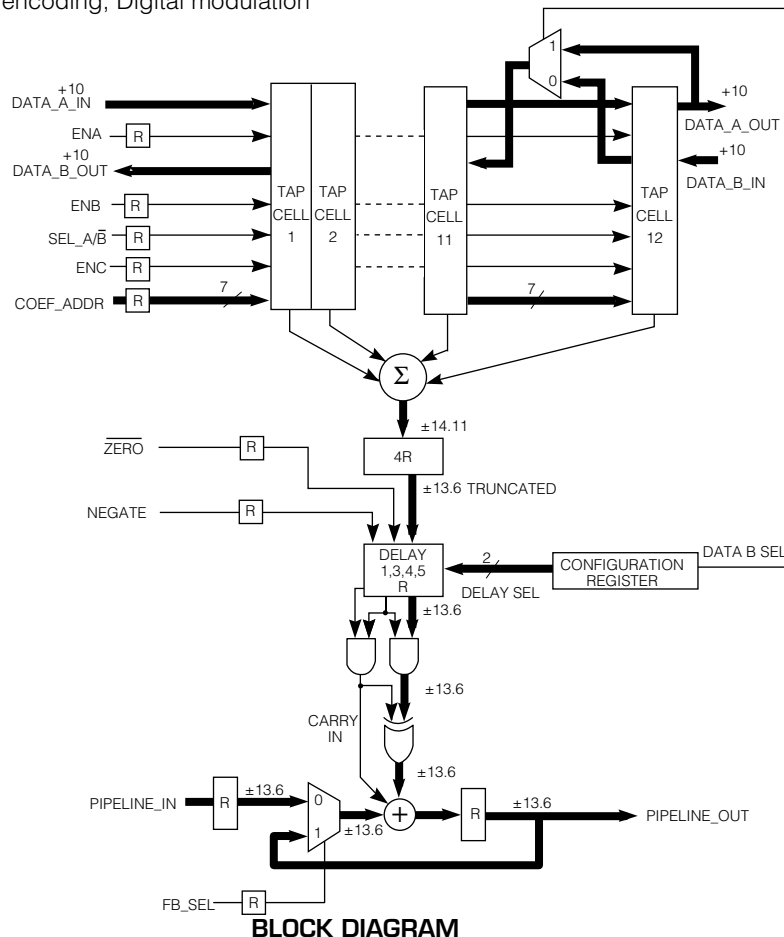

**BLOCK DIAGRAM**

## I/O DESCRIPTION

| SYMBOL                       | PIN NO.   | TYPE | DESCRIPTION  |
|------------------------------|---|------|--|
| V <sub>DD</sub>              | 1, 10, 20, 29, 40, 41, 59, 69, 80, 81, 90, 99, 109, 120, 121, 129, 140, 150, 160                              |      | +5 V power supply pins. 0.1μF capacitors between the V <sub>CC</sub> and GND pins are recommended.   |
| GND                          | 3, 6, 8, 19, 33, 36, 39, 46, 49, 60, 73, 76, 79, 83, 86, 88, 100, 113, 116, 119, 122, 125, 139, 153, 155, 159 |      | Device ground.   |
| CLK_IN                       | 138   | I    | System clock. All inputs except for CONFIGURE, and all internal registers are clocked on the rising edge of CLK_IN.  |
| DATA_A_IN (9-0)              | 127, 128, 130-137   | I    | Input data to registers A0 - A11. 9 bit signed or 10 bit unsigned data.  |
| DATA_B_IN (9-0)              | 141-149, 151  | I    | Input data to registers B11 - B0. 9 bit signed or 10 bit unsigned data.  |
| ENA                          | 23  | I    | Shift enable for A0 - A11. Enables shifting of A registers when high.  |
| ENB                          | 24  | I    | Shift enable for B0 - B11. Enables shifting of B registers when high.  |
| ENC                          | 25  | I    | Enable for C0-C11. Enables C registers when high. The C registers transfer data from either the A or B registers depending on the state of SEL_A/B.  |
| SEL_A/B                      | 22  | I    | Selects A or B registers. Selects registers A when high or registers B when low to be transferred to the C registers.  |
| COEF_DATA (7-0)              | 96-98, 101-105  | I    | Data bus for coefficients and configuration register:<br>a) Parallel and microprocessor loading modes : COEF_DATA (7-0) is used to load 8 bit data into internal RAM.<br>b) Serial Loading mode: COEF_DATA (7) is used to serially load the internal RAM.<br>c) Configuration mode: COEF_DATA (6-0) are inputs to the CONFIGURATION register.                                      |
| COEF_ADDR (9-0)              | 78, 77, 75, 74, 72, 47, 45-42   | I    | Address bus for internal RAM (address 0 → 107):<br>a) Run mode: COEF_ADDR (6-0) selects one of the 108 sets of 12 coefficients in the internal RAM.<br>b) Parallel and micro-processor loading modes: Selects the internal RAM address for the 8-bit data loading COEF_DATA (7-0).   |
| $\overline{\text{COEF\_WR}}$ | 17  | I    | Enable for COEF_DATA (7-0). $\overline{\text{LOAD\_EN}}$ must be enabled for $\overline{\text{COEF\_WR}}$ to work:<br>a) Parallel and micro-processor loading modes : Enables COEF_DATA (7-0) registers or loading 8 bit data in internal RAM.<br>b) Serial Loading mode: On a high to low transition, a one bit data gets clocked in to the internal RAM through COEF_DATA bit 7. |
| $\overline{\text{LOAD\_EN}}$ | 18  | I    | Used during loading mode. This signal selects a particular GF9101 device when 2 or more share the same bus for loading. The particular GF9101 device is selected when set low. $\overline{\text{LOAD\_EN}}$ must be enabled for $\overline{\text{COEF\_WR}}$ . For a single GF9101 using the serial loading, this pin can be set low.  |
| NEGATE                       | 126   | I    | This signal negates the filter sum before it enters the pipelined output section when high.  |
| $\overline{\text{ZERO}}$     | 123   | I    | Zeros filter sum before it enters the pipelined output section when low.   |
| FB_SEL                       | 124   | I    | Feedback select. Selects data in PIPELINE_IN when low or filter sum in PIPELINE_OUT when high to the input of the output accumulator.  |

**I/O DESCRIPTION**

| SYMBOL              | PIN NO.   | TYPE | DESCRIPTION  |
|---------------------|---|------|--|
| CONFIGURE           | 21  | I    | GF9101 reset/configure. Resets the GF9101 when high for at least one clock period. Loads COEF_DATA (6-0) into the CONFIGURATION register on a high to low transition. This bit is set low in run mode. When CONFIGURE is high, the GF9101 is reset but the values in the internal RAM and registers in the run mode sections are not altered. This means that the GF9101 may be reconfigured after the internal RAM has been loaded. |
| PIPELINE_IN (19-0)  | 38,37, 35, 34, 32-30, 28-26, 15-11, 9, 7, 5, 4, 2               | I    | Pipeline input. Input to the output accumulator when FB_SEL is low.  |
| DATA_A_OUT (9-0)    | 71, 70, 68-61   | O    | Output data from register A11.   |
| DATA_B_OUT (9-0)    | 58-50, 48   | O    | Output data from register B0.  |
| PIPELINE_OUT (19-0) | 82, 84, 85, 87, 89, 91-95, 106-108, 110-112, 114, 115, 117, 118 | O    | Pipeline output. Output of the accumulator or PIPELINE_IN depending on FB_SEL.   |
| S_LOAD_CMP          | 16  | O    | Serial loading complete.<br>a) Serial loading mode: When high, indicates that all the internal RAM has been loaded.  |
| SCAN_IN, SCAN_EN    | 157, 156  |      | Set low.   |
| TEST                | 158   |      | Set high.  |
| POUT, SCANOUT       | 152, 154  |      | No Connect.  |

Note: All unused inputs of the GF9101 should be connected to GND

**GF9101 OPERATION**

The GF9101 has two operating modes: the load mode and the run mode. In the load mode, the coefficients for the filters are written to the internal RAM. In the run mode, the GF9101 is used to filter signals.

Before the GF9101 can filter signals, two steps must be performed:

1. CONFIGURATION - is accomplished by writing one 7 bit word into the CONFIGURATION REGISTER. This register holds static operating parameters that affect both the load mode and the run mode.
2. MEMORY LOADING - is done after configuration. The internal RAM must be loaded with at least one of the 108 filter coefficient sets before signals can be processed.

**CONFIGURATION**

The GF9101 is reset by holding CONFIGURE high for at least one clock cycle. Configuration occurs upon a high to low transition on the CONFIGURE pin. This transition registers COEF\_DATA (6-0) into the CONFIGURATION REGISTER. Table 1 shows the meaning of each bit in the CONFIGURATION REGISTER.

When CONFIGURE is high, the GF9101 is reset but the values in the internal RAM and registers in the run mode sections are not altered. This means that the GF9101 may be reconfigured after the internal RAM has been loaded.

**MEMORY LOADING**

The GF9101 contains 12 tap cells with 108 12-bit memory locations for each tap. When loading the memory, the tap cells must be viewed as 6 memory banks with 108 24-bit memory locations in each bank. Each memory bank is assigned to a pair of tap cells as shown in Table 2.

During configuration, either the parallel, microprocessor, or serial loading is selected. When in the load mode, the memory outputs are undefined. Please refer to the GF9101 block diagram and notice that, even though the memory outputs are undefined, several valid outputs may be in the processing section below the multipliers and can exit the GF9101 correctly. This would be useful for adaptive filtering where the tap memories can be changed while the GF9101 outputs are still valid. During power up, the internal RAM of the GF9101 is in a random state, and is not initialized to zero.

TABLE 1: Configuration Register Format

| CONFIGURATION REGISTER BIT<br>COEF_DATA(6-0) | MEANING  |                        |
|--|--|------------------------|
| 0  | MODE A (1 if A input signed, 0 if unsigned)  |                        |
| 1  | MODE B (1 if B input signed, 0 if unsigned)  |                        |
| 3, 2   | DELAY_SEL selects delay for pipelining:  |                        |
|  | Bits 3, 2  | Delay in CLK_IN cycles |
|  | 0, 0   | 1                      |
|  | 0, 1   | 3                      |
|  | 1, 0   | 4                      |
| 1, 1   | 5  |                        |
|  |  |                        |
| 4  | DATA_B_SEL 0 selects B12 for two 12 tap filters or one 24 tap filter by externally connecting DATA_A_OUT to DATA_B_IN. DATA_B_SEL 1 selects A12 for a 23 tap filter. |                        |
| 6,5  | LOAD MODE SELECT (see below)   |                        |
|  | Bits 6, 5  | Loading mode           |
|  | 0, 0   | Serial                 |
|  | 0, 1   | Parallel               |
|  | 1, 0   | Microprocessor         |
|  | 1, 1   | Reserved               |

TABLE 2: Memory Locations for Internal RAM

| MEMORY BANKS (BITS) | TAPS (BITS) |
|---------------------|-------------|
| 0 (23-12)           | 0 (11-0)    |
| 0 (11-0)            | 2 (11-0)    |
| 1 (23-12)           | 3 (11-0)    |
| 1 (11-0)            | 4 (11-0)    |
| 2 (23-12)           | 5 (11-0)    |
| 2 (11-0)            | 6 (11-0)    |
| 3 (23-12)           | 7 (11-0)    |
| 3 (11-0)            | 8 (11-0)    |
| 4 (23-12)           | 9 (11-0)    |
| 4 (11-0)            | 10 (11-0)   |
| 5 (23-12)           | 11 (11-0)   |
| 5 (11-0)            | 12 (11-0)   |

**PARALLEL LOADING**

If parallel loading is selected, both the  $\overline{\text{COEF\_WR}}$  pin and the  $\overline{\text{LOAD\_EN}}$  pin determine whether the GF9101 is in the load mode. When  $\overline{\text{COEF\_WR}}$  and  $\overline{\text{LOAD\_EN}}$  are both low, the load mode is selected, the run mode is disabled, and writes to memory can occur. Parallel loading is random access and synchronous.

Data is written through COEF\_DATA (7-0) and its destination is determined by COEF\_ADDR (9-0). Coefficient memory is loaded by writing 8 bits at a time, first to two temporary registers (bits 15 -0) and finally to the desired memory bank (bits 23-0). Each memory bank word is loaded in three clock cycles. COEF\_ADDR (9-7) defines the address location for temporary registers (TEMP\_REG\_A and TEMP\_REG\_B) and memory banks. COEF\_ADDR (6-0) determines the filter coefficient address (0 -107) in the internal RAM. COEF\_ADDR (6-0) must be less than 108. In Table 3, COEF\_ADDR (9-7) determines the following:

TABLE 3: Temporary Loading Registers and Memory Banks

| COEF_ADDR(9-7)<br>(binary) | DESTINATION      | NUMBER OF BITS |
|----------------------------|------------------|----------------|
| 111                        | TEMP_REG_B       | 8 (15-8)       |
| 110                        | TEMP_REG_A       | 8 (7-0)        |
| 101                        | MB5 <sup>1</sup> | 24 (23-0)      |
| 100                        | MB4              | 24 (23-0)      |
| 011                        | MB3              | 24 (23-0)      |
| 010                        | MB2              | 24 (23-0)      |
| 001                        | MB1              | 24 (23-0)      |
| 000                        | MB0              | 24 (23-0)      |

NOTE 1: Memory Bank No. 5

TEMP\_REG\_A and TEMP\_REG\_B temporarily hold memory bits, (7-0) and (15-8) respectively. Three 8 bit writes are necessary to write one 24-bit memory as follows:

1. Load COEF\_DATA (7-0) into TEMP\_REG\_A
2. Load COEF\_DATA (7-0) into TEMP\_REG\_B
3. Load COEF\_DATA (7-0), TEMP\_REG\_B (7-0), and TEMP\_REG\_A (7-0) into the selected memory bank, MB0-MB5 (23-0).

While COEF\_ADDR (9-7) selects MB0-MB5 for writing, COEF\_ADDR (6-0) selects the memory bank location that the 24-bit word is written into. Parallel loading is synchronous with CLK\_IN. When  $\overline{\text{COEF\_WR}}$  and  $\overline{\text{LOAD\_EN}}$  are both low, 8-bit words will be written on the rising edge of CLK\_IN. Consecutive writes may be done indefinitely by keeping  $\overline{\text{COEF\_WR}}$  and  $\overline{\text{LOAD\_EN}}$  low. A parallel loading timing diagram is shown in Figure 1.

The timing diagram shown in Figure 1 loads the memories shown in Table 4:

TABLE 4: Memory Loaded into Internal RAM in Parallel Load Mode

| TAP (location) | 12-bit WORD IN HEX. | MEMORY BANK |
|----------------|---------------------|-------------|
| 1 (0)          | FB2                 | MB0         |
| 2 (0)          | EF4                 | MB0         |
| 11 (107)       | CCC                 | MB5         |
| 12 (107)       | DDD                 | MB5         |

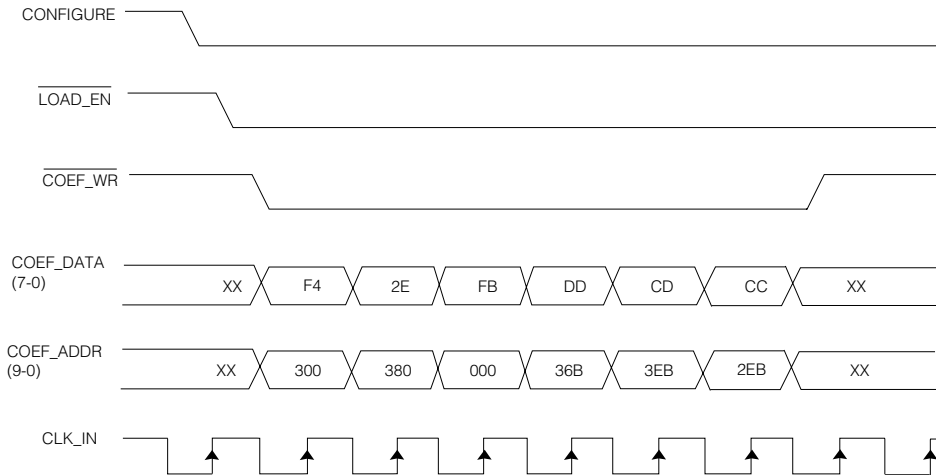

Fig. 1 Parallel Loading Timing Diagram

The address generated is shown in Table 5.

Timing for the parallel loading signals is the same as that for other synchronous inputs.

TABLE 5: Address Generation for Parallel Loading Example

| DESTINATION | COEF_ADDR (9-7) IN BINARY | COEF_ADDR (6-0) IN HEX | COEF_ADDR (9-0) IN HEX |
|-------------|---------------------------|------------------------|------------------------|
| TEMP_REG_A  | 110                       | X                      | 300                    |
| TEMP_REG_B  | 111                       | X                      | 380                    |
| MB0         | 000                       | 0                      | 000                    |
| TEMP_REG_A  | 110                       | X                      | 36B or 300             |
| TEMP_REG_B  | 111                       | X                      | 3EB or 380             |
| MB5         | 101                       | 6B                     | 2EB                    |

## MICROPROCESSOR LOADING

If microprocessor loading is selected, the  $\overline{\text{LOAD\_EN}}$  pin alone determines the run mode or the load mode. When  $\overline{\text{LOAD\_EN}}$  is low, the load mode is selected, the run mode is disabled, but a write will not occur until  $\overline{\text{COEF\_WR}}$  is low.

Microprocessor loading is random access and asynchronous. Like parallel loading, microprocessor loading uses COEF\_DATA (7-0) and COEF\_ADDR (9-0) to write three 8-bit words for each 24-bit memory written. Addressing is the same as for parallel loading. In microprocessor mode, at least one set of filter coefficients

need to be loaded into the internal RAM. If location 0 is used for filtering, MB0 > MB5 must be loaded for this location. The example shown in Figure 2 loads the value BB<sub>H</sub> into TEMP\_REG\_A.

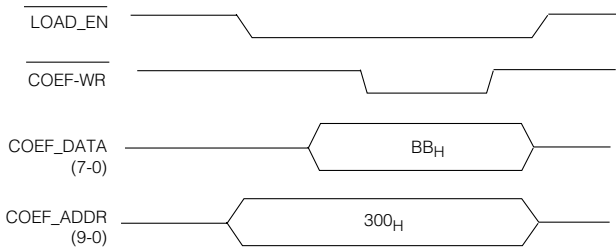

Fig. 2 Microprocessor Loading Timing Diagram

**SERIAL LOADING**

Serial loading is sequential and synchronous. If serial loading is selected the GF9101 will not enter the run mode until the entire serial load sequence is completed at which time the S\_LOAD\_CMP signal will go high. A bit will be written each time **LOAD\_EN** is low and **COEF\_WR** makes a high to low transition. Once the GF9101 is configured for serial loading, 24 x 108 x 6 = 15552 bits must be written before the run mode is entered automatically. The 15552 bits must be entered in the order defined in Table 6. MB0 is loaded first from RAM location 0 starting to fill the first 12 bits of tap 2. MB5 RAM location 107, tap 11 is loaded last.

When the serial load sequence is completed, S\_LOAD\_CMP will go high and the run mode will be active. Below is a serial loading timing diagram. This example shows the serial loading start-up sequence. Notice that the falling edge of **COEF\_WR** is used to register the serial data. The frequency of **COEF\_WR** should be ≤ 1/4 CLK\_IN frequency.

TABLE 6: Serial Mode Loading Order

| Memory Bank 0   |             | Memory Bank 1   |            | Memory Bank 5     |            | Ram Location |
|-----------------|-------------|-----------------|------------|-------------------|------------|--------------|
| TAP 2           | TAP 1       | TAP4            | TAP 3      | TAP12             | TAP 11     |              |
| 1,2,3 .... 12   | 13 ..... 24 | 2593 ..... 2617 |            | 5185 ..... 5208   |            |              |
| 0,1,2 .... 11   | 0 ..... 11  | 0 ..... 11      | 0 ..... 11 | 0 ..... 11        | 0 ..... 11 | 0            |
| 25 ..... 48     |             | 2618 ..... 2642 |            | 5209 ..... 5233   |            |              |
| 0 ..... 11      | 0 ..... 11  | 0 ..... 11      | 0 ..... 11 | 0 ..... 11        | 0 ..... 11 | 1            |
| ⋮               | ⋮           | ⋮               | ⋮          | ⋮                 | ⋮          | ⋮            |
| 2568 ..... 2592 |             | 5160 ..... 5184 |            | 15528 ..... 15552 |            |              |
| 0,1,2 .... 11   | 0 ..... 11  | 0 ..... 11      | 0 ..... 11 | 0 ..... 11        | 0 ..... 11 | 107          |

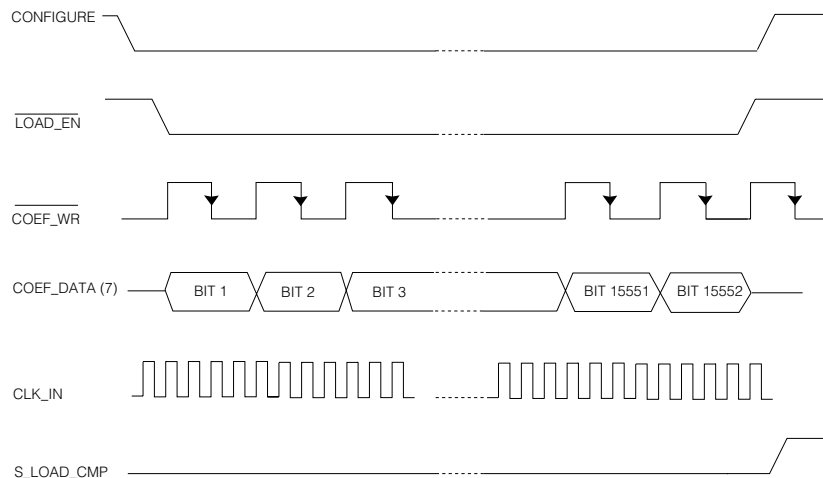

Fig. 3 Serial Mode Timing Diagram

## FILTER ARCHITECTURE

For the following discussion on filter architecture, refer to the GF9101 Block Diagram and Figure 4.

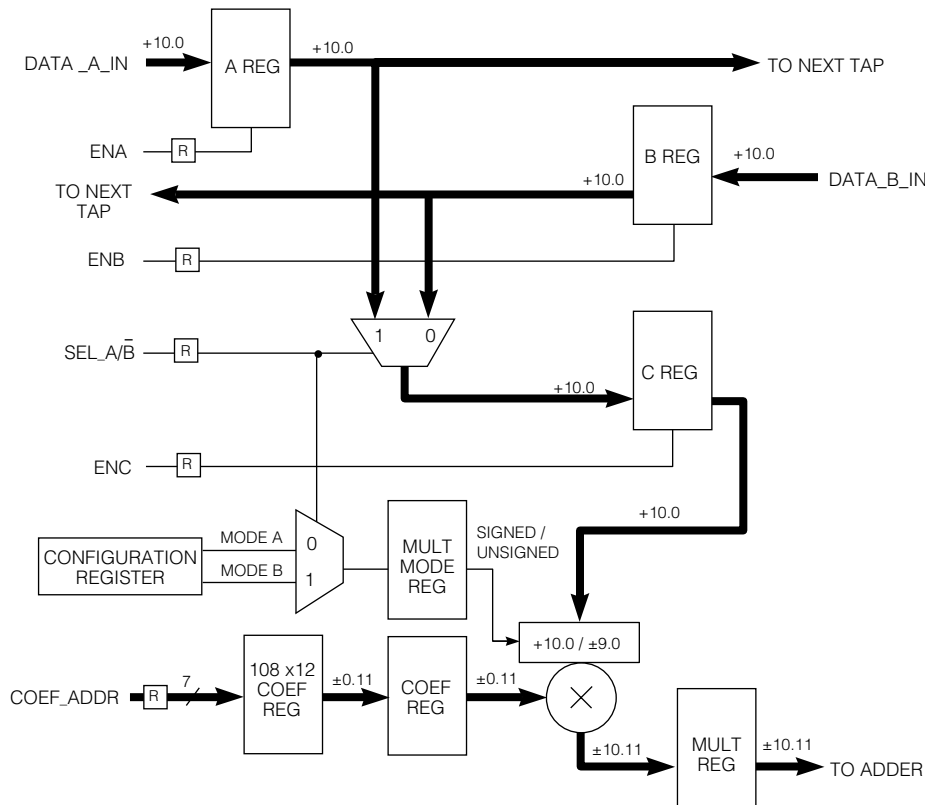

Fig. 4 Tap Cell (1-12)

### COEFFICIENT MULTIPLICATION AND ADDITION STAGE

Two shift registers, A and B, are used to shift input data through the GF9101. Notice that if DATA\_B\_SEL was set low during configuration, data applied at DATA\_A\_IN enters at tap 1 and exits from tap 12, while data applied at DATA\_B\_IN enters at tap 12 and exits from tap 1. This gives two 12 tap filters. If DATA\_B\_SEL was set high during configuration, data applied at DATA\_A\_IN enters at tap 1, reverses direction at tap 12 (bypasses REG\_12B) and exits from tap 1 on DATA\_B\_OUT, while DATA\_B\_IN is disabled. This gives a 23 tap filter. ENA and ENB control the shifting of the input data. The C register holds the next set of 12 input values to be applied to the multipliers.

If ENC is high, SEL\_A/B, determines whether the A or B shift register data enters the C register. SEL\_A/B, also determines whether the MODE A or MODE B control signal enters the MULT\_MODE register. The value in the MULT\_MODE register determines whether the input data to the multiplier is recognized as signed or unsigned. MODE A and MODE B are separate, static control signals which determine signed/unsigned for A or B input data respectively. They are common to all taps. When using the GF9101 as a 23 or 24 tap filter (combining REG\_A and REG\_B to get a single filter output), MODE A and MODE B should be in the same state. If not, a signed/unsigned

mismatch will occur. One needs to be cautious while using the GF9101 as two separate filters with MODE A and MODE B not in the same state (data entering REG\_A is signed/unsigned while in REG\_B it is the opposite of REG\_A). If ENC is low and SEL\_A/B, changes state, a signed/unsigned mismatch will occur. To avoid an error under these circumstances, always make ENC high after a SEL\_A/B, state change.

The input values in the C register are multiplied by the coefficient values in the COEF register and the result enters an adder tree. The coefficients that enter the COEF register are stored in the internal RAM and are selected by the externally controlled COEF\_ADDR (6-0) bus, which is common to all taps. At the output of the adder tree is the untruncated sum of taps 1 through 12.

This sum is then truncated as shown in the GF9101 Block diagram. The sum then passes through a variable delay along with the ZERO and NEGATE signals. The variable delay is provided so that complementary sums from cascaded GF9101's may be added together in the pipelined output stage. The ZERO signal zeros the sum and the NEGATE signal negates the sum.

**PIPELINE\_IN, PIPELINE\_OUT STAGE**

The calculated filter sum from the adder tree and delay enters into the pipelined output stage. Figure 5 shows the block diagram for the pipelined structure. FB\_SEL determines whether the sum is added to the current PIPELINE\_OUT or the registered PIPELINE\_IN. The result is then registered at PIPELINE\_OUT. When using one GF9101, this configuration can be used to add two partial filter sums from the A and B registers. Another application would be to use the PIPELINE\_IN port for adding DC offset or SYNC

and BURST signals (i.e. for 4:2:2 to  $4f_{SC}$  rate conversion). This can be achieved by clocking in the SYNC and BURST signals from an external PROM connected to the PIPELINE\_IN.

By connecting PIPELINE\_OUT of one GF9101 device to PIPELINE\_IN of another, up to three GF9101's may be cascaded to form larger filters.

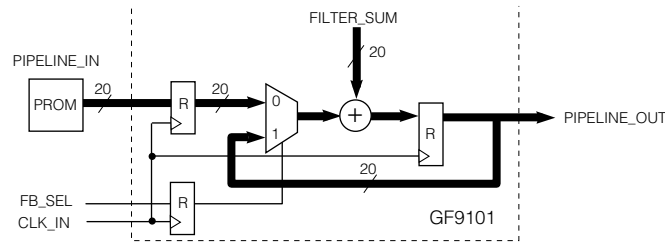

Fig. 5 Block Diagram for Pipelined Output Stage

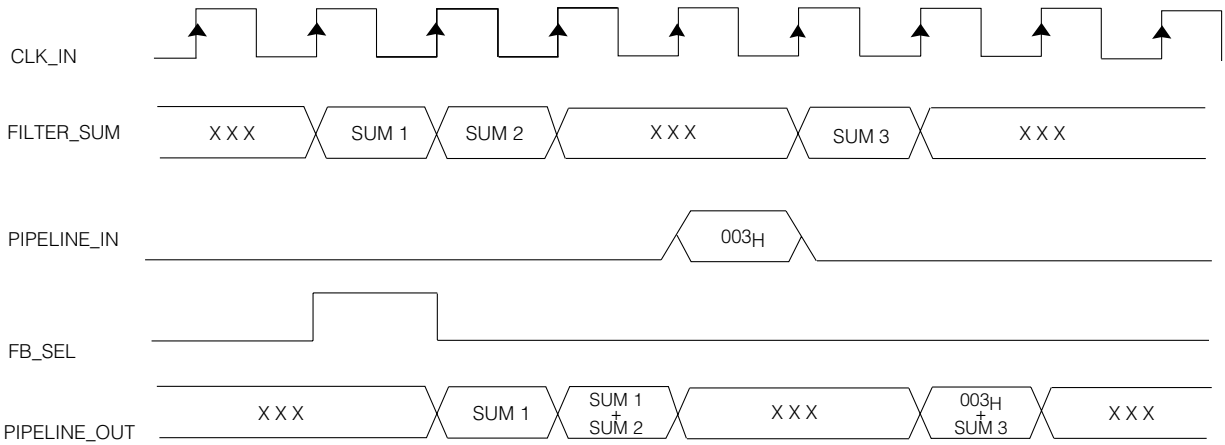

Fig. 6 Timing Diagram for the Pipelined Output Stage

**APPLICATION NOTES**

Video applications for the GF9101 include video rate conversion and high performance FIR filters. The following section presents a number of examples which show odd and even symmetric and asymmetric filters.

**ODD-TAP SYMMETRIC FILTER**

The GF9101 can be configured as an Odd-tap symmetric filter. A 23-tap odd-symmetric filter using one GF9101 will be discussed. For an odd-tap symmetric filter, the configuration word is shown in Table 7.

multiplied by the data in reg. A<sub>12</sub> and reg.B<sub>12</sub> is bypassed. The data is shifted into the register by clocking ENA and ENB at the same time at half the CLK\_IN frequency. The filter timing is shown in Figure 8.

The maximum data rate using this filter configuration is 20 MHz, where the filter is clocked at twice the data rate of 40 MHz, the frequency of CLK\_IN. The filter has input data  $A_n$  and filter data coefficients  $C_n$  ( $C_0 \rightarrow C_{11}$ ) as shown in Figure 7. The input enters the filter at DATA\_A\_IN and exits the filter from DATA\_B\_OUT. The coefficient C<sub>11</sub> is only

TABLE 7: Configuration Word for an Odd-Tap Symmetric Filter

| BIT NO. | CONFIGURATION WORD | DESCRIPTION                                    |
|---------|--------------------|--|
| 0       | 1                  | Data A and B are both signed data <sup>2</sup> |
| 1       | 1                  |  |
| 2       | 0                  | One register delay                             |
| 3       | 0                  |  |
| 4       | 1                  | 23-tap filter, bypass reg. B_12                |
| 5       | X                  | Depending on loading mode.                     |
| 6       | X                  | (See Table 1)                                  |

NOTE:

2: Bits 0 and 1 should have the same value for a 23 or 24 tap filter.

TABLE 8: Internal RAM Addresses and Contents

| COEF_ADDR (6-0) | MEMORY CONTENTS                     |
|-----------------|-------------------------------------|
| 00 <sub>H</sub> | 12 coefficients, for tap 1—> tap 12 |

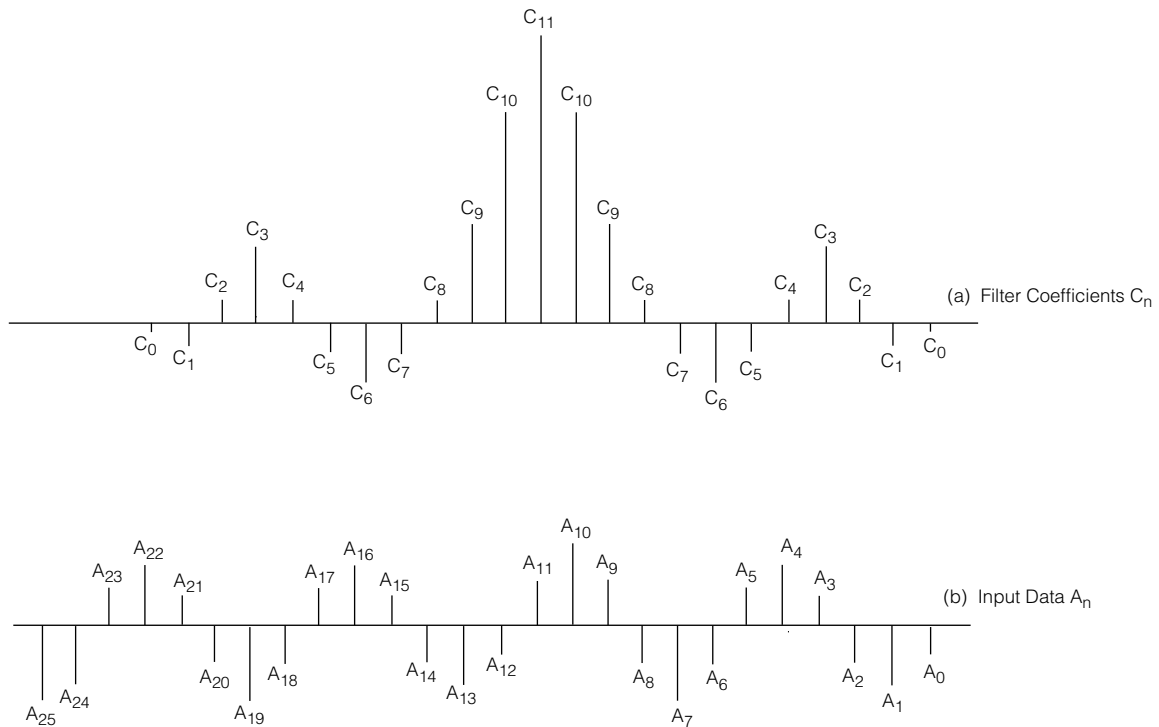

Fig. 7 Input Data  $A_n$  and Coefficients  $C_n$

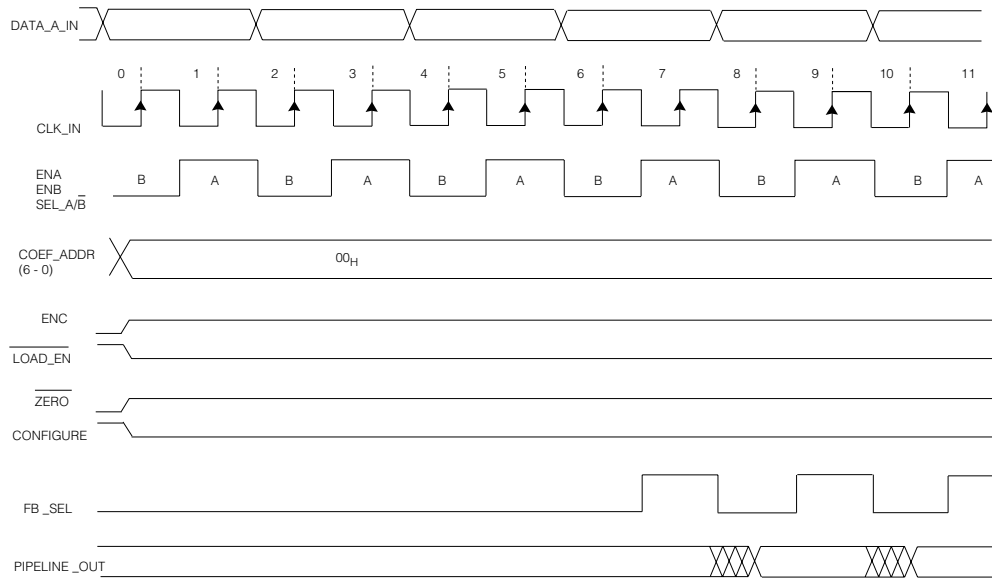

Fig. 8 Timing Diagram for a 23-Tap Odd-Symmetric Filter

Assuming that the data  $A_0 \rightarrow A_{21}$  has already been shifted into the filter registers, by clocking ENA and ENB the data  $A_{22}$  enters DATA\_A\_IN (Figure 9a). During the first CLK\_IN rising edge, the data in the A registers ( $A_{22} \rightarrow A_{11}$ ) are selected by  $SEL\_A/\bar{B}$ , to be multiplied by the coefficients,  $C_0 \rightarrow C_{11}$  in memory location 0, COEF\_ADDR  $00_H$ . During the second CLK\_IN rising edge the data in B registers ( $A_0 \rightarrow A_{10}$ ) are selected by  $SEL\_A/\bar{B}$ , to be multiplied by the coefficients,  $C_0 \rightarrow C_{10}$  (Figure

9b). After passing through the adder tree and the delay (4 CLK\_IN cycles in total), the two sums are added in the pipeline section of the filter. FB\_SEL selects PIPELINE\_IN during CLK\_IN period 5, at which time a DC offset could be introduced at PIPELINE\_IN to be added to the sum. During CLK\_IN period 6, FB\_SEL selects PIPELINE\_OUT and the final filter sum is calculated and passed through to PIPELINE\_OUT.

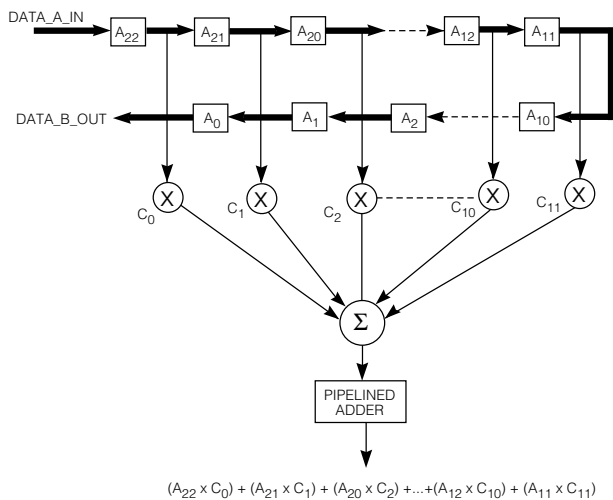

Fig. 9a Data Flow Diagram for a 23 Tap Odd-Symmetric Filter

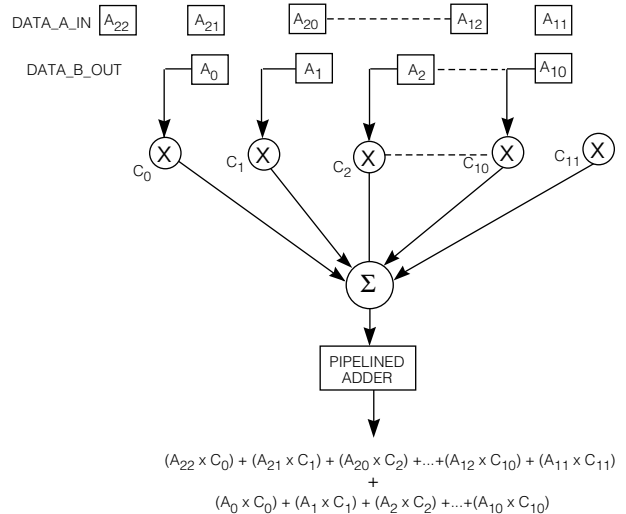

Fig. 9b Data Flow Diagram for a 23 Tap Odd-Symmetric Filter

**EVEN-TAP SYMMETRIC FILTER**

The GF9101 can be configured as an even-tap symmetric filter. A 24-tap symmetric filter can be configured using one GF9101 by connecting the outputs of DATA\_A\_OUT to the inputs of DATA\_B\_IN and taking the output at

PIPELINE\_OUT. For a 24-tap symmetric filter, the configuration word is shown in Table 9.

TABLE 9: Configuration Word for a 24-tap Symmetric Filter

| BIT NO. | CONFIG. WORD | DESCRIPTION  |
|---------|--------------|--|
| 0       | 1            | <sup>3</sup> Data A and B are both signed data                               |
| 1       | 1            |  |
| 2       | 0            | One register delay   |
| 3       | 0            |  |
| 4       | 0            | 24-tap filter, connect the outputs of DATA_A_OUT to the inputs of DATA_B_IN. |
| 5       | X            | Depending on the loading mode  |
| 6       | X            | See Table 1  |

NOTE

3. Bits 0 and 1 should have the same value for a 23 or 24 tap filter

The filter coefficients are shown in Figure 10. The timing is very similar to that of the even-symmetric case.

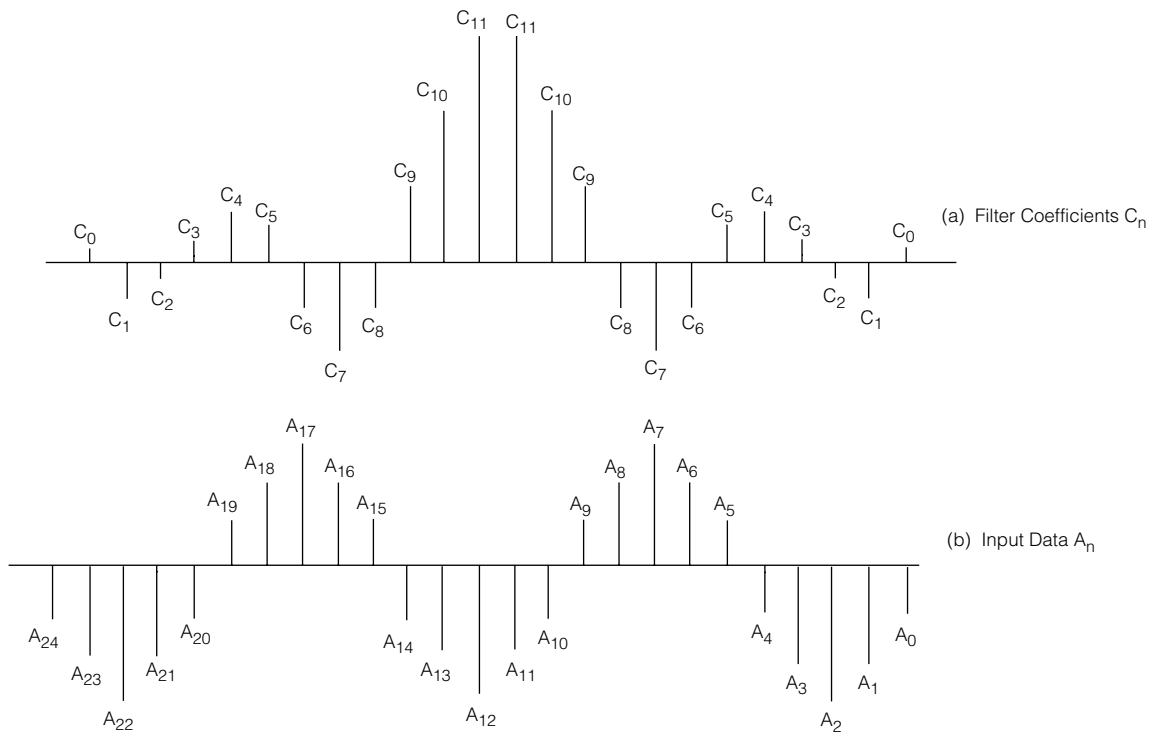

Fig. 10 Input Data  $A_n$  and Coefficients  $C_n$

**ASYMMETRIC FILTER**

The GF9101 can be used as a 24-tap asymmetric filter by configuring it the same way as the even-symmetric case. The difference is in the memory locations since the asymmetric case uses 24 different coefficients, i.e. two sets of filter coefficients. The filter coefficients and the memory locations are shown in Table 10.

The timing diagram is shown in Figure 11. The data flow diagrams are shown in Figures 11a and 11b.

TABLE 10: Internal RAM Address & Contents for a 24-tap Asymmetric Filter

| COEF_ADDR (6-0) | MEMORY CONTENTS  |
|-----------------|--|
| 00 <sub>H</sub> | First set of 12 coefficients, $C_0 \rightarrow C_{11}$     |
| 01 <sub>H</sub> | Second set of 12 coefficients, $C_{23} \rightarrow C_{12}$ |

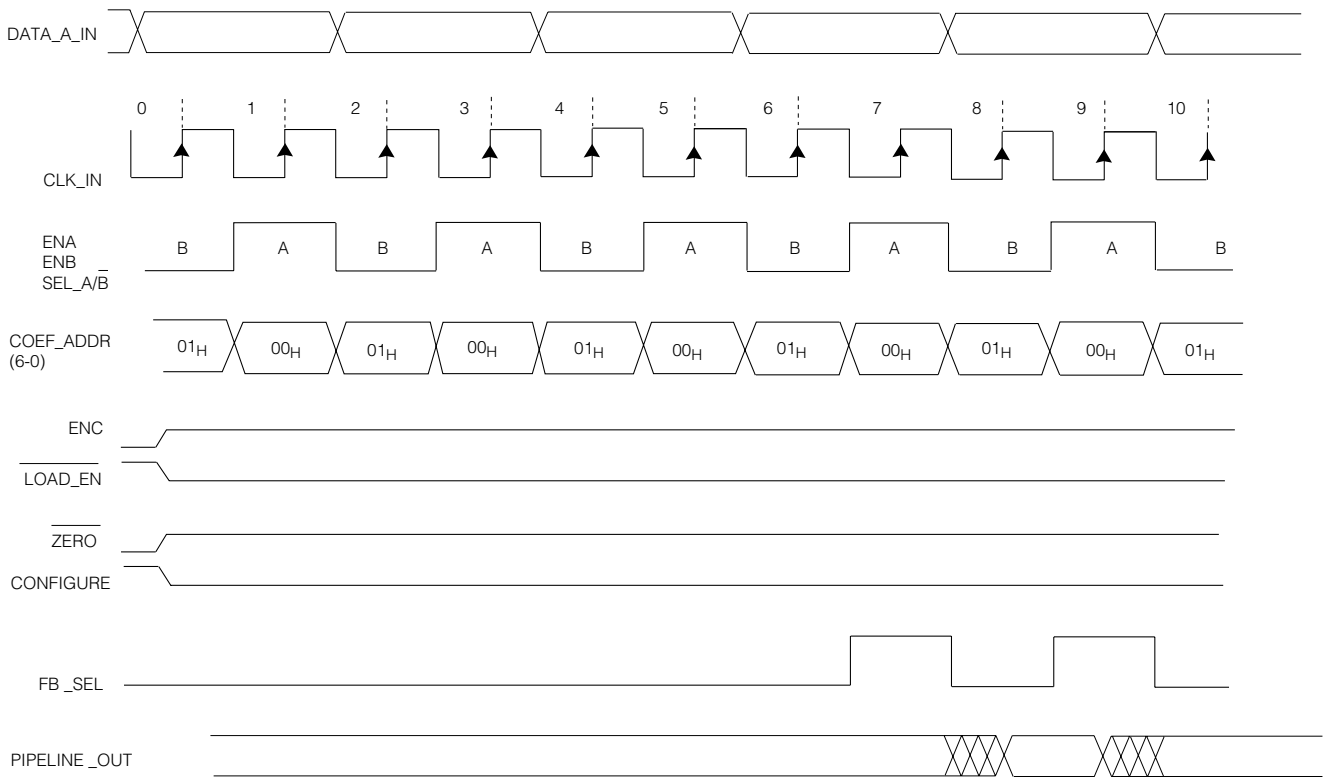

Fig. 11 Timing Diagram for a 24 Tap Asymmetric Filter

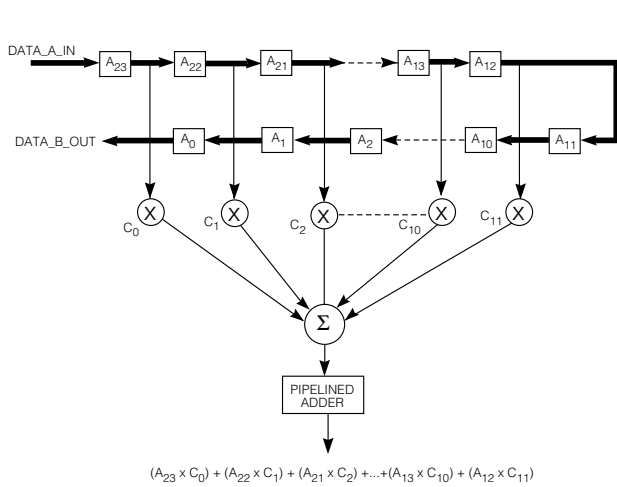

Fig. 11a Data Flow Diagram for a 24 Tap Asymmetric Filter

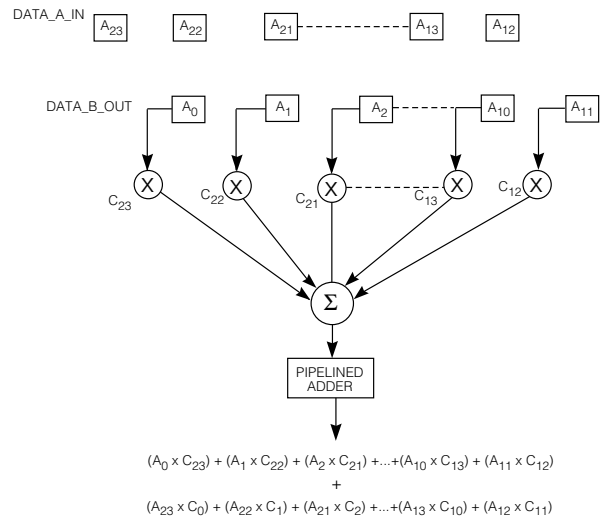

Fig. 11b Data Flow Diagram for a 24 Tap Asymmetric Filter

**CASCADING**

In the previous section, configuration for a 24 tap filter using only one GF9101 was shown. To realize higher order (>24) filters, up to three GF9101's would allow a 72 tap FIR filter to be configured without any additional hardware. In Figure 13, two GF9101's are cascaded together to obtain a 48 tap filter. The data enters DATA\_A\_IN (device number 1) and exits from DATA\_B\_OUT (device number 1). In device number 2, the DATA\_A\_OUT bus is connected to DATA\_B\_IN in order to feed the data back in to the B12

register of the same device. The contents of the configuration register will be different for the two devices to compensate for a three register delay introduced when two GF9101's are cascaded to get a 48 tap filter. The configuration register contents are shown in Table 11.

For the 48 tap filter, input data  $A_n$  and coefficients  $C_n$  are shown in Figure 12. The pipelined output section of the 48 tap filter is shown in Figure 14. Note that two register delays are introduced due to R2 and R3 between the accumulators of device number 1 and number 2. An additional delay is

introduced when the filter-sum is fed back to be added to the next sum by selecting FB\_SEL\_1. The timing diagram for the 48 tap asymmetric filter is shown in Figure 15. The processing clock runs at twice the data rate since the A and B registers of the GF9101 are multiplexed internally..

TABLE 11 Configuration Word for the Cascaded GF9101's

| BIT NO. | DEVICE NO. 1<br>CONFIG.<br>WORD | DEVICE NO. 2<br>CONFIG.<br>WORD | DESCRIPTION   |
|---------|---------------------------------|---------------------------------|---|
| 0       | 1                               | 1                               | Data A and B are both signed data.  |
| 1       | 1                               | 1                               |   |
| 2       | 0                               | 0                               | 1 clock cycle delay in device no. 1 and 4 clock delay in device no. 2   |
| 3       | 0                               | 1                               |   |
| 4       | 0                               | 0                               |   |
| 5       | 0                               | 0                               | Using each device as 2 x 12 tap filters. Note that in device no. 2 DATA_A_OUT is externally connected to DATA_B_IN. |
| 6       | 0                               | 0                               |   |

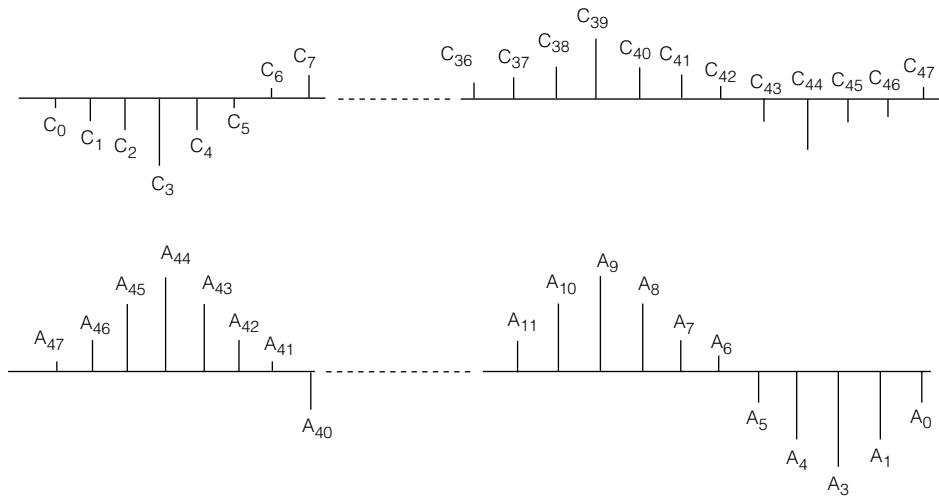

Fig. 12 Input Data  $A_n$  and Coefficients  $C_n$

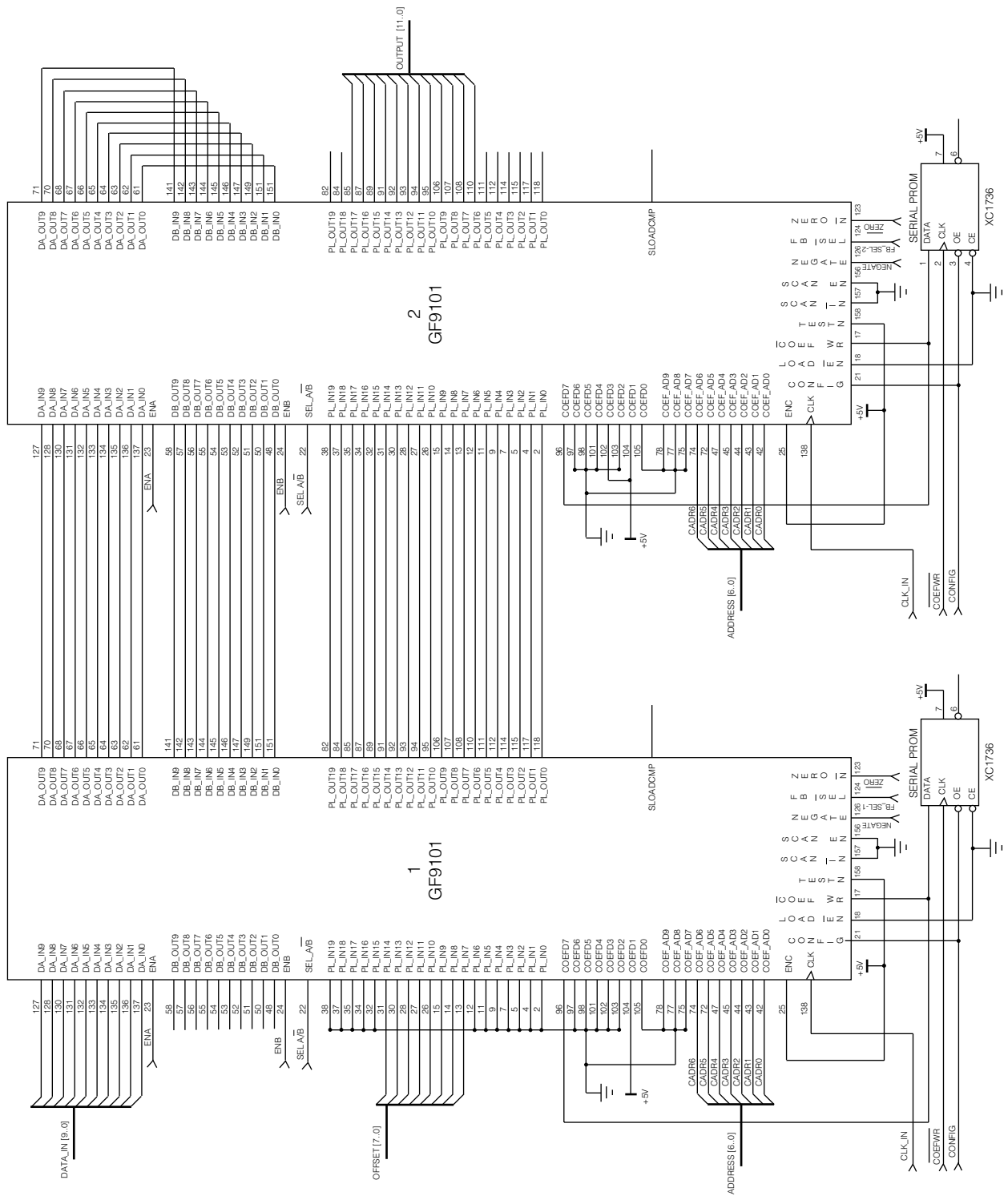

Fig. 13

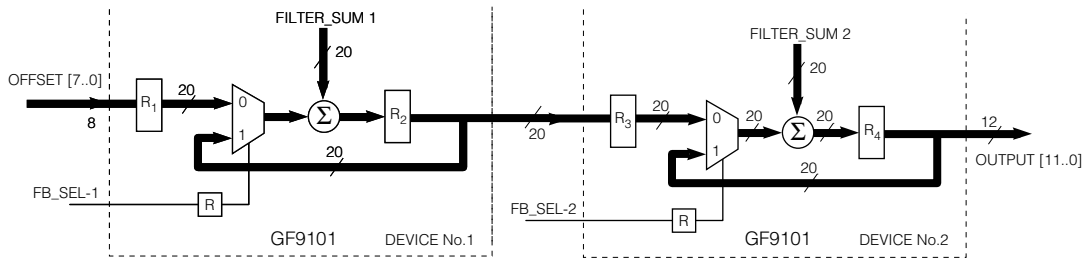

Fig. 14 Pipelined Output Stages for Two Cascaded GF9101's

TABLE 12: Internal RAM Address and Contents for a 48-tap Asymmetric Filter using Two Cascaded GF9101's

| COEF_ADDR       | INTERNAL RAM CONTENTS          |                                |
|-----------------|--------------------------------|--------------------------------|
|                 | Device No. 1                   | Device No. 2                   |
| 00 <sub>H</sub> | C0 → C11 (registers A1 → A12)  | C12 → C23 (registers A1 → A12) |
| 01 <sub>H</sub> | C47 → C36 (registers B1 → B12) | C35 → C24 (registers B1 → B12) |

Dedicated serial PROM's can be used to load the coefficients into the internal RAM of each GF9101. Note that when data is fed back into DATA\_B\_IN, it enters register B12 of device number 2. Therefore, while loading the coefficients into the internal RAM for the B registers the

coefficients should be arranged as shown in Table 12. If a single source is used for coefficient loading, the LOAD\_EN signal is used to select the appropriate device. Also, the S\_LOAD\_CMP signal can be used as an indicator for a successful load.

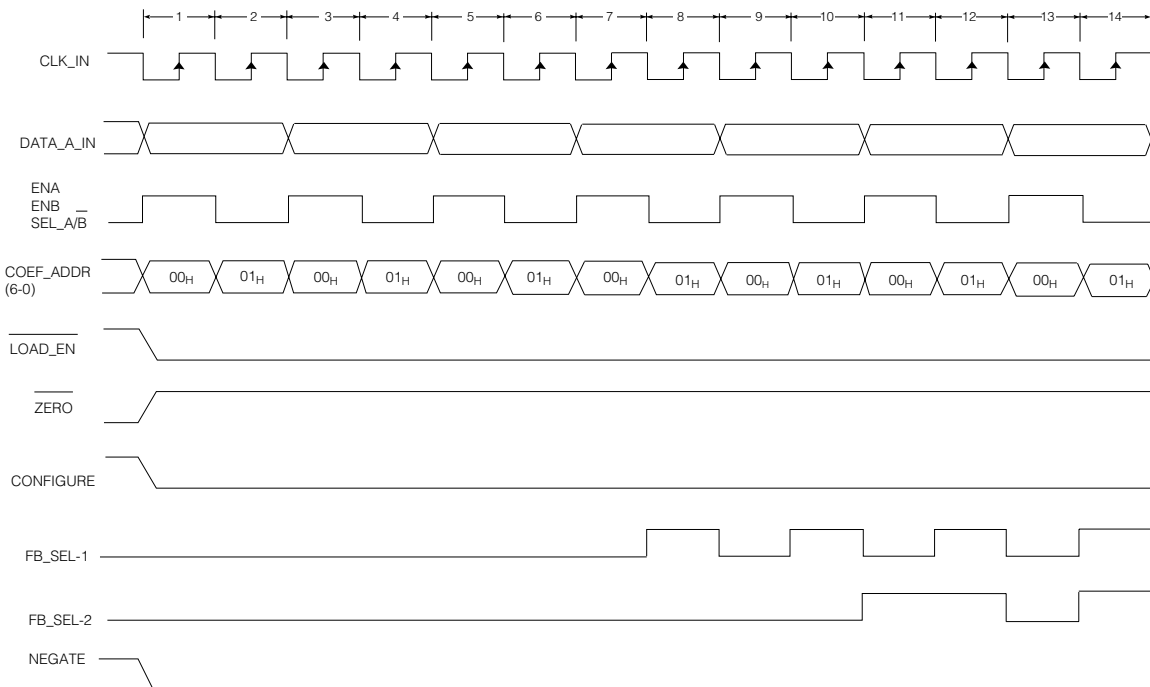

Fig. 15 Timing Diagram for a 48 Tap Asymmetric Filter

| Pin No. | Signal Name | Notes                | Pin No. | Signal Name |
|---------|-------------|----------------------|---------|-------------|
| 127     | DA-IN9      |                      | 71      | DA-OUT9     |
| 128     | DA-IN8      |                      | 70      | DA-OUT8     |
| 130     | DA-IN7      |                      | 68      | DA-OUT7     |
| 131     | DA-IN6      |                      | 67      | DA-OUT6     |
| 132     | DA-IN5      |                      | 66      | DA-OUT5     |
| 133     | DA-IN4      |                      | 65      | DA-OUT4     |
| 134     | DA-IN3      |                      | 64      | DA-OUT3     |
| 135     | DA-IN2      |                      | 63      | DA-OUT2     |
| 136     | DA-IN1      |                      | 62      | DA-OUT1     |
| 137     | DA-IN0      |                      | 61      | DA-OUT0     |
| 23      | ENA         |                      |         |             |
| 141     | DB-IN9      |                      | 58      | DB-OUT9     |
| 142     | DB-IN8      |                      | 57      | DB-OUT8     |
| 143     | DB-IN7      |                      | 56      | DB-OUT7     |
| 144     | DB-IN6      |                      | 55      | DB-OUT6     |
| 145     | DB-IN5      |                      | 54      | DB-OUT5     |
| 146     | DB-IN4      |                      | 53      | DB-OUT4     |
| 147     | DB-IN3      |                      | 52      | DB-OUT3     |
| 148     | DB-IN2      |                      | 51      | DB-OUT2     |
| 149     | DB-IN1      |                      | 50      | DB-OUT1     |
| 151     | DB-IN0      |                      | 48      | DB-OUT0     |
| 24      | ENB         |                      |         |             |
| 22      | SELAB       |                      |         |             |
| 38      | PL-IN19     |                      | 82      | PL-OUT19    |
| 37      | PL-IN18     |                      | 84      | PL-OUT18    |
| 35      | PL-IN17     |                      | 85      | PL-OUT17    |
| 34      | PL-IN16     |                      | 87      | PL-OUT16    |
| 32      | PL-IN15     |                      | 89      | PL-OUT15    |
| 31      | PL-IN14     |                      | 81      | PL-OUT14    |
| 30      | PL-IN13     | +/- 5V               | 82      | PL-OUT13    |
| 28      | PL-IN12     | 1, 10, 20, 29,       | 83      | PL-OUT12    |
| 27      | PL-IN11     | 40, 41, 59, 69,      | 84      | PL-OUT11    |
| 26      | PL-IN10     | 80, 81, 90, 99, 109, | 85      | PL-OUT10    |
| 15      | PL-IN9      | 120, 121, 129,       | 106     | PL-OUT9     |
| 14      | PL-IN8      | 140, 150, 160        | 106     | PL-OUT8     |
| 13      | PL-IN7      |                      | 108     | PL-OUT7     |
| 12      | PL-IN6      |                      | 110     | PL-OUT6     |
| 11      | PL-IN5      |                      | 111     | PL-OUT5     |
| 9       | PL-IN4      |                      | 112     | PL-OUT4     |
| 7       | PL-IN3      | GND                  | 114     | PL-OUT3     |
| 5       | PL-IN2      | 3, 6, 8, 19, 33,     | 115     | PL-OUT2     |
| 4       | PL-IN1      | 36, 39, 46, 49,      | 117     | PL-OUT1     |
| 2       | PL-IN0      | 60, 73, 76, 79, 83,  | 118     | PL-OUT0     |
| 96      | COEF-D7     | 86, 88, 100,         |         |             |
| 97      | COEF-D6     | 113, 116, 119,       |         |             |
| 98      | COEF-D5     | 122, 125, 139,       |         |             |
| 101     | COEF-D4     | 153, 155, 159        |         |             |
| 102     | COEF-D3     |                      |         |             |
| 103     | COEF-D2     |                      |         |             |
| 104     | COEF-D1     |                      |         |             |
| 105     | COEF-D0     |                      |         |             |
| 78      | COEF-AD9    |                      |         |             |
| 77      | COEF-AD8    |                      |         |             |
| 75      | COEF-AD7    |                      |         |             |
| 74      | COEF-AD6    |                      |         |             |
| 72      | COEF-AD5    |                      |         |             |
| 47      | COEF-AD4    |                      |         |             |
| 45      | COEF-AD3    |                      |         |             |
| 44      | COEF-AD2    |                      |         |             |
| 43      | COEF-AD1    |                      |         |             |
| 42      | COEF-AD0    |                      |         |             |
| 25      | ENC         |                      |         |             |
| 138     | CLK_IN      |                      |         |             |

GF9101 Pin Designations

**ABSOLUTE MAXIMUM RATINGS**

| PARAMETER                              | VALUE                             |
|--|-----------------------------------|
| Supply Voltage                         | -0.3 to +7.0 V                    |
| Input Voltage                          | -0.3 to (V <sub>DD</sub> + 0.3) V |
| Short Circuit Duration (single output) | 1 second                          |
| Storage Temp                           | - 40 to +125 C                    |

**RECOMMENDED OPERATING CONDITIONS**

| PARAMETER         | SYMBOL          | LIMIT          | UNIT |
|-------------------|-----------------|----------------|------|
| DC Supply Voltage | V <sub>DD</sub> | + 3.0 to + 5.5 | V    |
| Ambient           | T <sub>A</sub>  | 0 to +70       | C    |
| Junction          | T <sub>J</sub>  | +150           | C    |

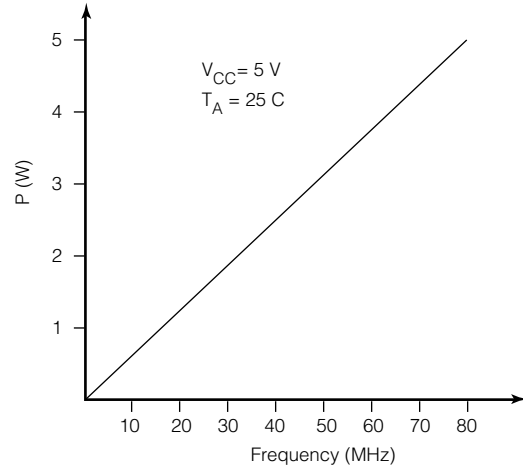

GF9101 Power Consumption vs Clock Rate

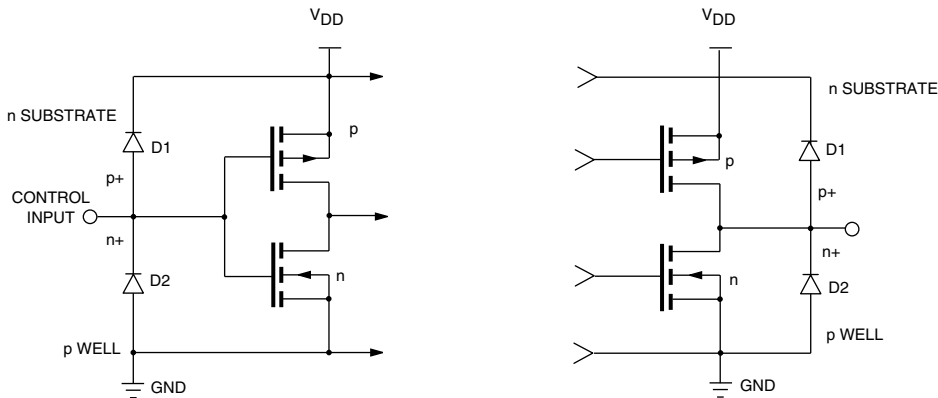

Fig. 16 Equivalent Input/Output Circuit

**DC ELECTRICAL CHARACTERISTICS**

$V_{CC} = 5V \pm 5\%$ ,  $T_A = 0^\circ C$  to  $70^\circ C$  unless otherwise shown

| PARAMETER                    | SYMBOL    | CONDITIONS                          | MIN | TYP  | MAX | UNITS   |
|------------------------------|-----------|-------------------------------------|-----|------|-----|---------|
| Voltage Input LOW            | $V_{IL}$  |                                     | -   | -    | 1.5 | V       |
| Voltage Input HIGH           | $V_{IH}$  |                                     | 3.5 | -    | -   | V       |
| Voltage Output HIGH          | $V_{OH}$  |                                     | 2.4 | 4.5  | -   | V       |
| Switching Threshold          | $V_T$     |                                     | -   | 2.5  | -   | V       |
| Input Current                | $I_{IN}$  | $V_{IN} = V_{DD}$ or $V_{SS}$       | -10 | +/-1 | 10  | $\mu A$ |
| Output Current HIGH          | $I_{OH}$  | PIPELINE_OUT                        | -   | -    | 2   | mA      |
|                              | $I_{OH}$  | DATA_A_OUT, DATA_B_OUT              | -   | -    | 1   | mA      |
| Output Current LOW           | $I_{OL}$  | PIPELINE_OUT                        | -   | -    | 2   | mA      |
|                              | $I_{OL}$  | DATA_A_OUT, DATA_B_OUT              | -   | -    | 1   | mA      |
| Quiescent Supply Current     | $I_{DD}$  | $V_{IN} = V_{DD}$ or $V_{SS}$       | -   | 12   | -   | mA      |
| Output Short Circuit Current | $I_{OS}$  | $V_{DD} = \text{Max}, V_O = V_{DD}$ | 30  | 75   | 140 | mA      |
|                              |           | $V_{DD} = \text{Max}, V_O = 0V$     | 25  | 70   | 140 | mA      |
| Input Capacitance            | $C_{IN}$  |                                     | -   | 4.0  | -   | pF      |
| Output Capacitance           | $C_{OUT}$ |                                     | -   | 3.5  | -   | pF      |

**SWITCHING CHARACTERISTICS**

$V_{CC} = 5V \pm 5\%$ ,  $T_A = 0^\circ C$  to  $70^\circ C$  unless otherwise shown

|              |           |            |   |   |    |     |
|--------------|-----------|------------|---|---|----|-----|
| Output Delay | $t_D$     |            | - | 8 | -  | ns  |
| Setup Time   | $t_S$     | All Inputs | 2 | - | -  | ns  |
| Hold Time    | $t_H$     | All Inputs | 6 | - | -  | ns  |
| Clock Rate   | $f_{MAX}$ |            | - | - | 40 | MHz |

# GF9101 TIMING

GF9101

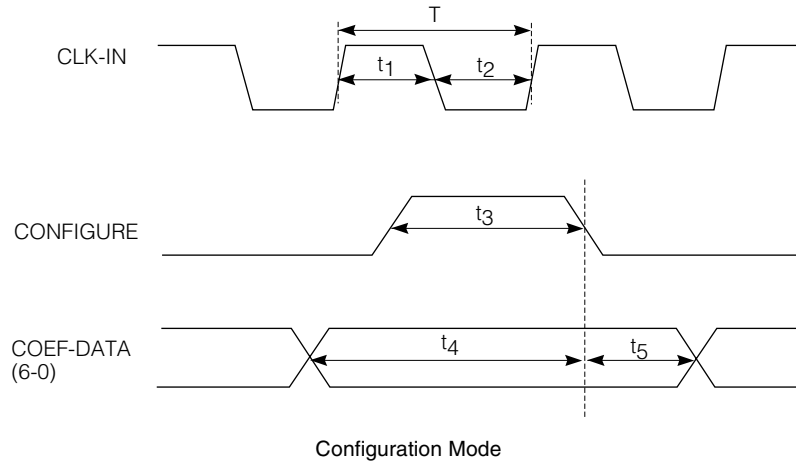

| DESCRIPTION |                                   | SYMBOL | MIN    | MAX | UNIT |
|-------------|-----------------------------------|--------|--------|-----|------|
| 1           | CLK_IN duration time (HIGH)       | $t_1$  | 12     |     | ns   |
| 2           | CLK_IN duration time (LOW)        | $t_2$  | 12     |     | ns   |
| 3           | CLK_IN period time                | $T$    | 25     |     | ns   |
| 4           | CONFIGURE pulse width             | $t_3$  | $T+10$ |     | ns   |
| 5           | COEF_DATA to configure setup time | $t_4$  | 10     |     | ns   |
| 6           | COEF_DATA to configure hold time  | $t_5$  | 5      |     | ns   |

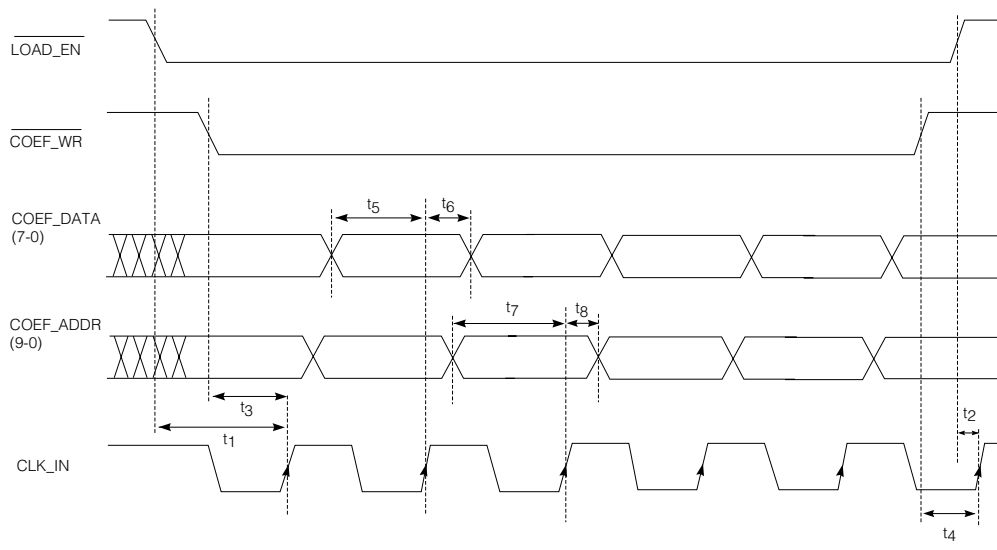

Memory Loading - Parallel Interface

| DESCRIPTION |   | SYMBOL | MIN | MAX | UNIT |
|-------------|---|--------|-----|-----|------|
| 1           | $\overline{\text{LOAD\_EN}}$ to CLK_IN set up time* | $t_1$  | 4   |     | ns   |
| 2           | $\overline{\text{LOAD\_EN}}$ to CLK_IN hold time**  | $t_2$  | 6   |     | ns   |
| 3           | $\overline{\text{COEF\_WR}}$ to CLK_IN set up time* | $t_3$  | 4   |     | ns   |
| 4           | $\overline{\text{COEF\_WR}}$ to CLK_IN hold time**  | $t_4$  | 6   |     | ns   |
| 5           | COEF_DATA to CLK_IN set up time                     | $t_5$  | 2   |     | ns   |
| 6           | COEF_DATA to CLK_IN hold time                       | $t_6$  | 6   |     | ns   |
| 7           | COEF_ADDR to CLK_IN set up time                     | $t_7$  | 2   |     | ns   |
| 8           | COEF_ADDR to CLK_IN hold time                       | $t_8$  | 6   |     | ns   |

\* to enable loading  
 \*\* to disable loading

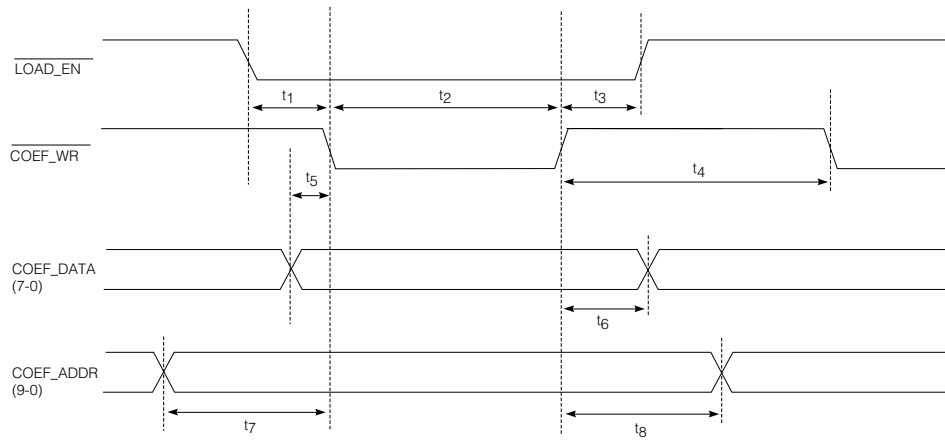

Memory Loading - Microprocessor Interface

| DESCRIPTION |  | SYMBOL | MIN | MAX | UNIT |
|-------------|--|--------|-----|-----|------|
| 1           | $\overline{\text{LOAD\_EN}}$ to $\overline{\text{COEF\_WR}}$ set up time | $t_1$  | 2   |     | na   |
| 2           | $\overline{\text{COEF\_WR}}$ puls width low                              | $t_2$  | 80  |     | ns   |
| 3           | $\overline{\text{LOAD\_EN}}$ to $\overline{\text{COEF\_WR}}$ hold time   | $t_3$  | 6   |     | ns   |
| 4           | $\overline{\text{COEF\_WR}}$ pulse width, high                           | $t_4$  | 20  |     | ns   |
| 5           | COEF_DATA to $\overline{\text{COEF\_WR}}$ set up time                    | $t_5$  | 10  |     | ns   |
| 6           | COEF_DATA to $\overline{\text{COEF\_WR}}$ hold time                      | $t_6$  | 10  |     | ns   |
| 7           | COEF_ADDR to $\overline{\text{COEF\_WR}}$ set up time                    | $t_7$  | 2   |     | ns   |
| 8           | COEF_ADDR to $\overline{\text{COEF\_WR}}$ hold time                      | $t_8$  | 6   |     | ns   |

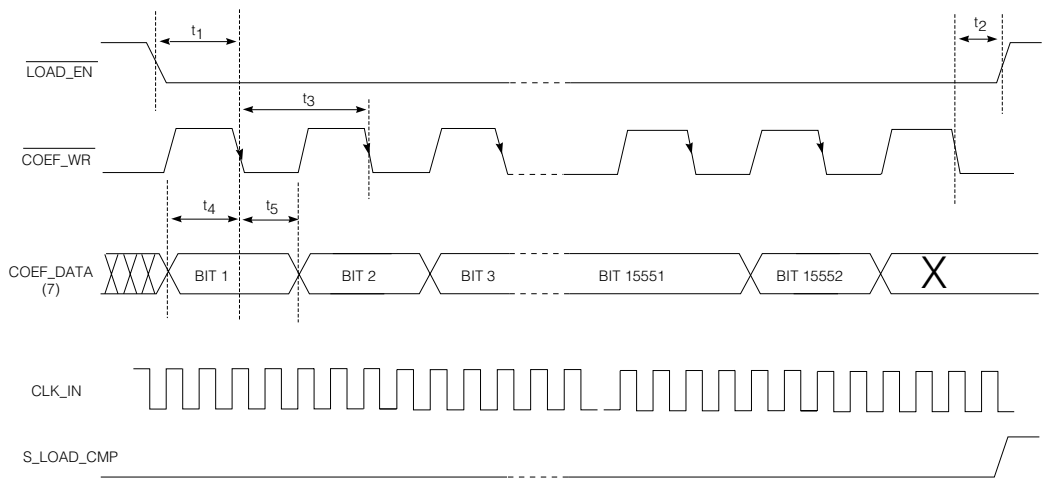

Memory Loading - Serial

| DESCRIPTION |  | SYMBOL | MIN | MAX | UNIT |
|-------------|--|--------|-----|-----|------|
| 1           | $\overline{\text{LOAD\_EN}}$ to $\overline{\text{COEF\_WR}}$ set up time | $t_1$  | 4   |     | ns   |
| 2           | $\overline{\text{LOAD\_EN}}$ to $\overline{\text{COEF\_WR}}$ hold time   | $t_2$  | 6   |     | ns   |
| 3           | $\overline{\text{COEF\_WR}}$ period                                      | $t_3$  | 4xT |     | ns   |
| 4           | COEF_DATA(7) to $\overline{\text{COEF\_WR}}$ set up time                 | $t_4$  | 2   |     | ns   |
| 5           | COEF_DATA(7) to $\overline{\text{COEF\_WR}}$ hold time                   | $t_5$  | 6   |     | ns   |

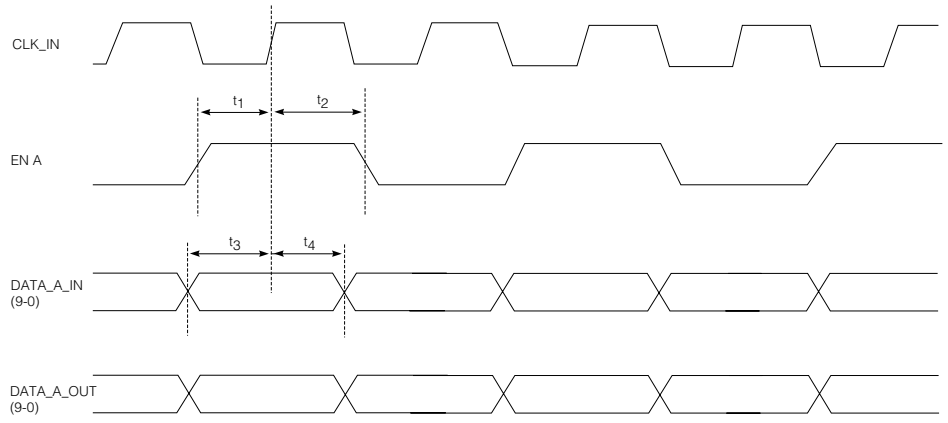

Run Mode

| DESCRIPTION |                                 | SYMBOL | MIN | MAX | UNIT |
|-------------|---------------------------------|--------|-----|-----|------|
| 1           | ENA to CLK_IN set up time       | $t_1$  | 2   |     | ns   |
| 2           | ENA to CLK_IN hold time         | $t_2$  | 6   |     | ns   |
| 3           | DATA_A_IN to CLK_IN set up time | $t_3$  | 2   |     | ns   |
| 4           | DATA_A_IN to CLK_IN hold time   | $t_4$  | 6   |     | ns   |

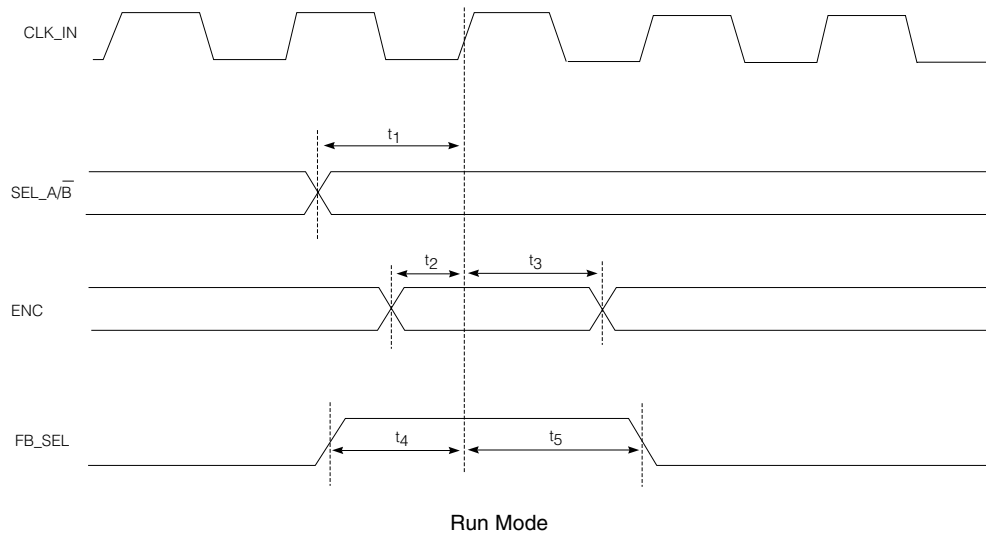

| DESCRIPTION |                               | SYMBOL | MIN | MAX | UNIT |
|-------------|-------------------------------|--------|-----|-----|------|
| 1           | SEL_A/B to CLK_IN set up time | $t_1$  | 2   |     | ns   |
| 2           | ENC to CLK_IN set up time     | $t_2$  | 2   |     | ns   |
| 3           | ENC to CLK_IN hold time       | $t_3$  | 6   |     | ns   |
| 4           | FB_SEL to CLK_IN set up time  | $t_4$  | 2   |     | ns   |
| 5           | FB_SEL to CLK_IN hold time    | $t_5$  | 6   |     | ns   |

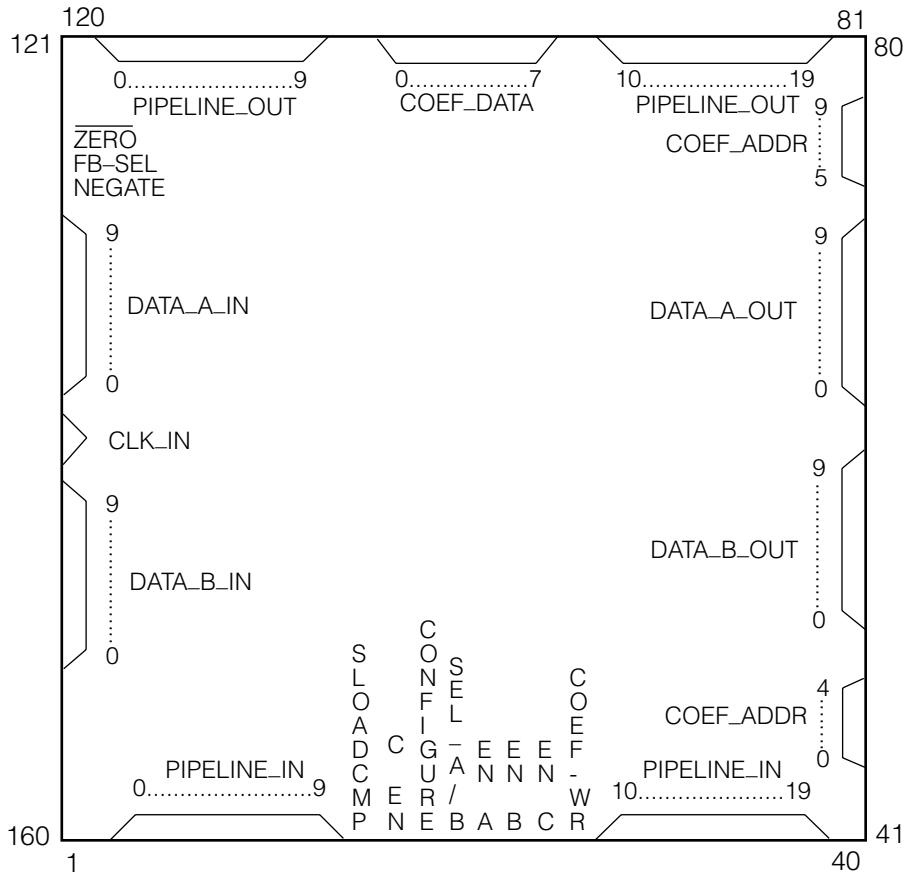

160 pin Metal Quad Pinout

GF9101

**CAUTION**  
 ELECTROSTATIC SENSITIVE DEVICES  
 DO NOT OPEN PACKAGES OR HANDLE EXCEPT AT A STATIC-FREE WORKSTATION



**DOCUMENT IDENTIFICATION**  
 DATA SHEET  
 The product is in production. Gennum reserves the right to make changes at any time to improve reliability, function or design, in order to provide the best product possible.

**REVISION NOTES:**  
 Remove 'Not Recommended for New Designs' Watermark.  
 Correct package name to 160 pin Metal Quad.

**GENNUM CORPORATION**

MAILING ADDRESS:  
 P.O. Box 489, Stn. A, Burlington, Ontario, Canada L7R 3Y3  
 Tel. +1 (905) 632-2996 Fax. +1 (905) 632-5946

SHIPPING ADDRESS:  
 970 Fraser Drive, Burlington, Ontario, Canada L7L 5P5

**GENNUM JAPAN CORPORATION**

C-101, Miyamae Village, 2-10-42 Miyamae, Suginami-ku  
 Tokyo 168-0081, Japan  
 Tel. +81 (03) 3334-7700 Fax. +81 (03) 3247-8839

**GENNUM UK LIMITED**

Centaur House, Ancells Bus. Park, Ancells Rd, Fleet, Hants, England GU13 8UJ  
 Tel. +44 (0)1252 761 039 Fax +44 (0)1252 761 114

Gennum Corporation assumes no responsibility for the use of any circuits described herein and makes no representations that they are free from patent infringement.

© Copyright October 1998 Gennum Corporation. All rights reserved. Printed in Canada.



LittleDiode supplies new, hard to find or obsolete electronic components and semiconductors all over the world.

With over two million different components listed you are sure to find the part you need.

Feel free to visit us today at our online store:

[LittleDiode.com](http://LittleDiode.com)

Looking forward to providing you with the best possible service.