

# GL 6551

## COMPANDER

### Description

The GL6551 is a compander IC to expand dynamic range at transmission/reception systems and to improve the tone quality by means of restricting noise. Two functions are loaded on the IC, the one is the compressor which has the 2/1 ratio of input/output ratio by logarithm, and the expander which has the 1/w ratio input/ output ratio by logarithm. The GL6551 equipped with input & filter Amp, DATA IN OUT terminal. The GL6551 is well suited for use in cellular radio MCA and handy telephone set, radio communication systems.

### Features

- Low operating supply voltage.
- Equipped with mute function and through function.
- Equipped with compressor MIC Amp and Expander INPUT Amp
- Equipped with Filter Buffer Amp
- Equipped with DATA IN OUT terminal.
- Operation Voltage (2.4 ~ 7.0V)
- Total gain (10~ 100dB)

### Pin Configuration

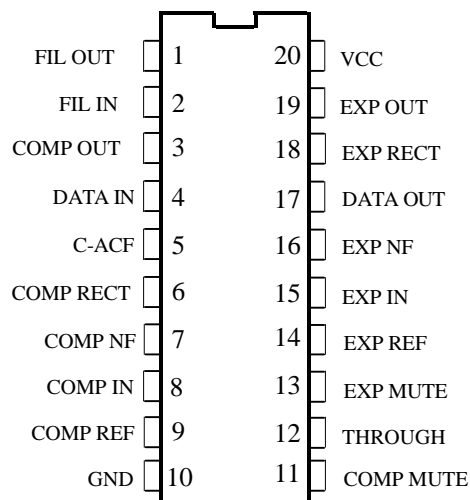

### Maximum Ratings

Parameter	symbol	Spec.	Unit	Remark
Supply Voltage	$V_{CC, MAX}$	10	V	
Power Dissipation	$P_{D, MAX}$	350	mW	
Storage Temperature	$T_{STG}$	-5 ~ 125	°C	

### Operating Conditions

Parameter	symbol	Spec.	Unit	Remark
Operating Voltage	$V_{OP}$	2.4 ~ 7	V	
Operating Temperature	$T_{OP}$	-30 ~ 70	°C	

Block Diagram

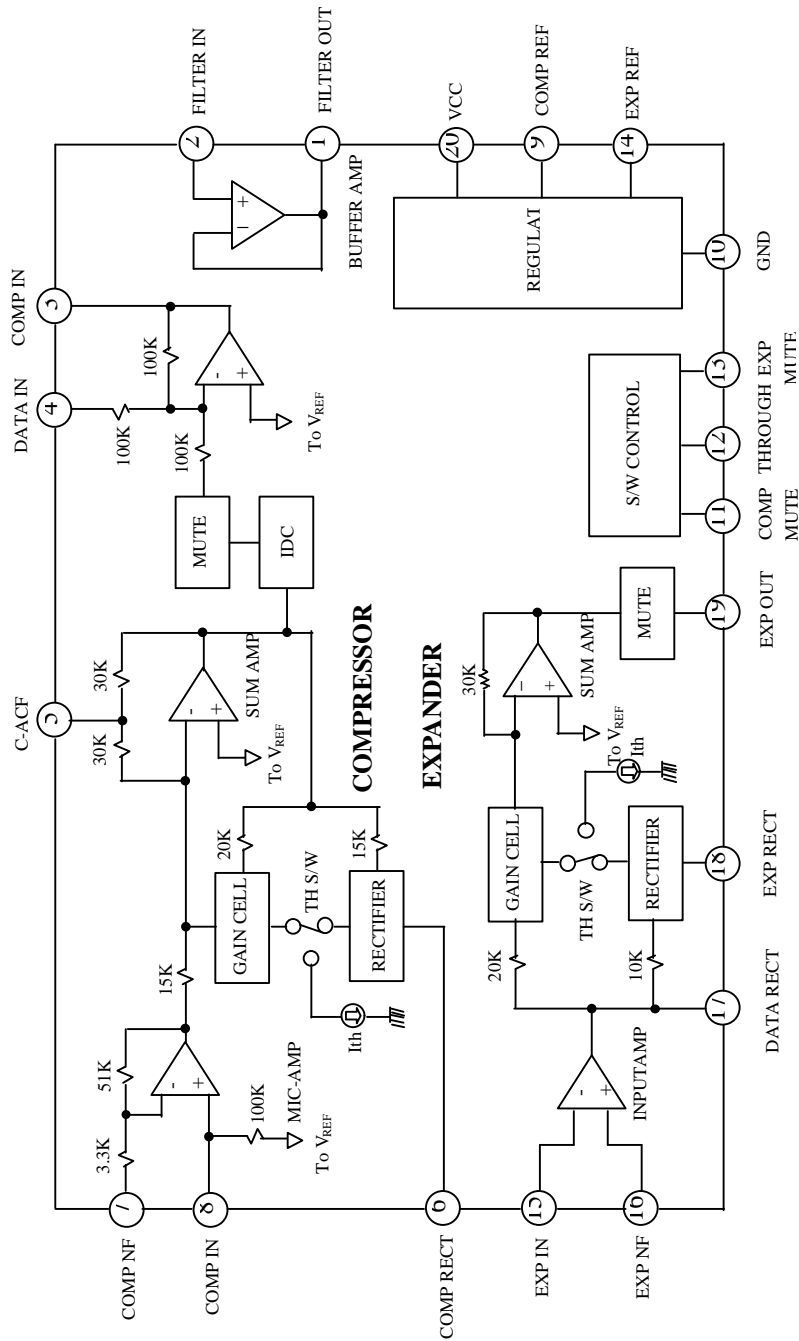

## Electrical Characteristics

Ta=25;  $\bar{E}$  Vcc=3.0V, f=1kHz, R1=10k $\Omega$ 

PARAMETER	SYMBOL	SPEC.			UNIT	CONDITION
		MIN	TYP	MAX		
Current Dissipation	I <sub>cc</sub>	-	4.0	6.5	mA	No Signal
Threshold Voltage	V <sub>th</sub>	0.9	1.15	1.30	V	11, 12, 13 Pin
Compressor						
Input impedance	Z <sub>in</sub>	90	120	-	K $\Omega$	
Input Reference Level	V <sub>inc</sub>	8	12.5	17	mVrms	V <sub>oc</sub> =30mVrms, V <sub>in</sub> =0dB*
Gain Deviation (1)	$\Delta$ Gc1	-0.5	0	0.5	dB	V <sub>in</sub> =-20dB *
Gain Deviation (2)	$\Delta$ Gc2	-1.0	0	1.0	dB	V <sub>in</sub> =-40dB *
Through ON OFF Diff.	$\Delta$ Gtc	-1.5	0	1.5	dB	V <sub>in</sub> =0dB, Pin12=0V*
T.H.D	THDc	-	0.5	1.0	%	V <sub>in</sub> =0dB
Output Noise Voltage	V <sub>nc</sub>	-	3.0	5.5	mVrms	R <sub>g</sub> =620 $\Omega$ *
Mute Attenuation	Attc	60	80	-	dB	V <sub>in</sub> =0dB, Pin11=0V *
Limiting Voltage	V <sub>limc</sub>	1.15	1.35	1.5	V <sub>p-p</sub>	
Data Pin Voltage Gain	G <sub>data</sub>	-0.5	0	0.5	dB	Pin4=300mVrms
Data Pin Max. Output	V <sub>Dmax</sub>	800	900	-	mVrms	THD=10% Point
Cross Talk	CTc	-	-35	-30	dB	ExpV <sub>in</sub> =30mVrms, R <sub>g</sub> =620 $\Omega$ *
Buffer Amp (LPF)						
Voltage Gain	G <sub>b</sub>	-0.5	0	0.5	dB	V <sub>in</sub> =300mVrms
Freq. Charact (1)	$\Delta$ f1	-	-3	-	dB	V <sub>in</sub> =300mVrms, f=3kHz
Freq. Charact (2)	$\Delta$ f2	-	-60	-	dB	V <sub>in</sub> =300mVrms, f=30kHz
T.H.D.	THDb	-	0.02	0.1	%	V <sub>in</sub> =300mVrms
Maximum Output Voltage	V <sub>Bmax</sub>	550	700	-	mVrms	THD=10% Point
Expander						
Output Reference Volt.	V <sub>oe</sub>	110	130	160	mVrms	V <sub>in</sub> =300mVrms=0dB *
Gain Deviation (1)	$\Delta$ Ge1	-0.5	0	0.5	DB	V <sub>in</sub> =-10dB *
Gain Deviation (2)	$\Delta$ Ge2	-1.0	0	1.0	DB	V <sub>in</sub> =-20dB *
Gain Deviation (3)	$\Delta$ Ge3	-1.5	0	2.0	DB	V <sub>in</sub> =-30dB *
Through ON OFF Diff.	$\Delta$ Gte	-2.5	-1	0.5	DB	V <sub>in</sub> =0dB, Pin12=0V *
T.H.D	THDe	-	0.5	1.5	%	V <sub>in</sub> =0dB
Output Noise Voltage	V <sub>ne</sub>	-	10	30	uVrms	R <sub>g</sub> =620 $\Omega$ *
Mute Attenuation	V <sub>E</sub> max	60	80	-	DB	V <sub>in</sub> =0dB, Pin13=0V *
Maximum Output Voltage	G <sub>i</sub>	700	800	-	mVrms	THD 10% Point
Input Amp Voltage Gain	V <sub>I</sub> max	14.5	15.5	16.5	DB	V <sub>in</sub> =0dB
Input Amp Max. Voltage	C <sub>Te</sub>	450	500	-	mVrms	THD=10% Point
Cross Talk		-	-70	-60	DB	CompV <sub>in</sub> =V <sub>inc</sub> , R <sub>g</sub> =620 $\Omega$ *

\* Measured by Noise Filter (CCITT Recommendation P. 53)

NO	SYMBOL	FUNCTION
1	FILTER OUT	Filter Amp Output Terminal.
2	FILTER IN	Filter Amp (+) Input Terminal. Make a various kinds Filters.
3	COMP OUT	Compressor Output Terminal.
4	DATA IN	Connected to (-) Input terminal of Compressor Output Amp through resistor Signal which is input to this terminal is output to COMP OUT (Pin3). (not compress)
5	C-ACF	Coupling capacitor connect Terminal. Determined Low cutoff frequency of Compressor block by capacitance.
6	COMP RECT	Rectifying Capacitor external connect Terminal. Determined Recovery time and Attack time of Compressor by Capacitance.
7	COMP NF	Input resistor and decoupling capacitor of Compressor Mic Amp external connect Terminal. Determined Mic Amp Gain by resistor. Max gain condition is not connect resistor.
8	COMP IN	Compressor Mic Amp (+) Input Terminal. Same potential with COMP REF (Pin 9).
9	COMP REF	Reference voltage of Compressor Internal Amp Output Terminal.
10	GND	Ground Terminal.
11	COMP MUTE	“L” state – Compressor Output Mute. Input signal of Data In terminal is output to COMP OUT (Pin3). “H” state – open.
12	THROUGH	“L”state – Compressor and Expander Logarithm 1 (Constant Gain) “H” state – open.
13	EXP MUTE	“L” state = Expander Output is muting. Data out to DATA OUT (Pin 17) Terminal. “H” state – open.
14	EXP REF	Reference voltage of Expander Internal Amp output Terminal.
15	EXP IN	Expander Input Amp (+) Input Terminal.
16	EXP NF	Expander Input Amp (-) Input Terminal.
17	DATA OUT	Expander Input Amp Input Terminal.
18	EXP RECT	Rectifying capacitor external connect Terminal. Determine Attack time and Recovery time of Expander by Capacitance.
19	EXP OUT	Expander Output Terminal.
20	Vcc	Power Supply.

Application Circuit

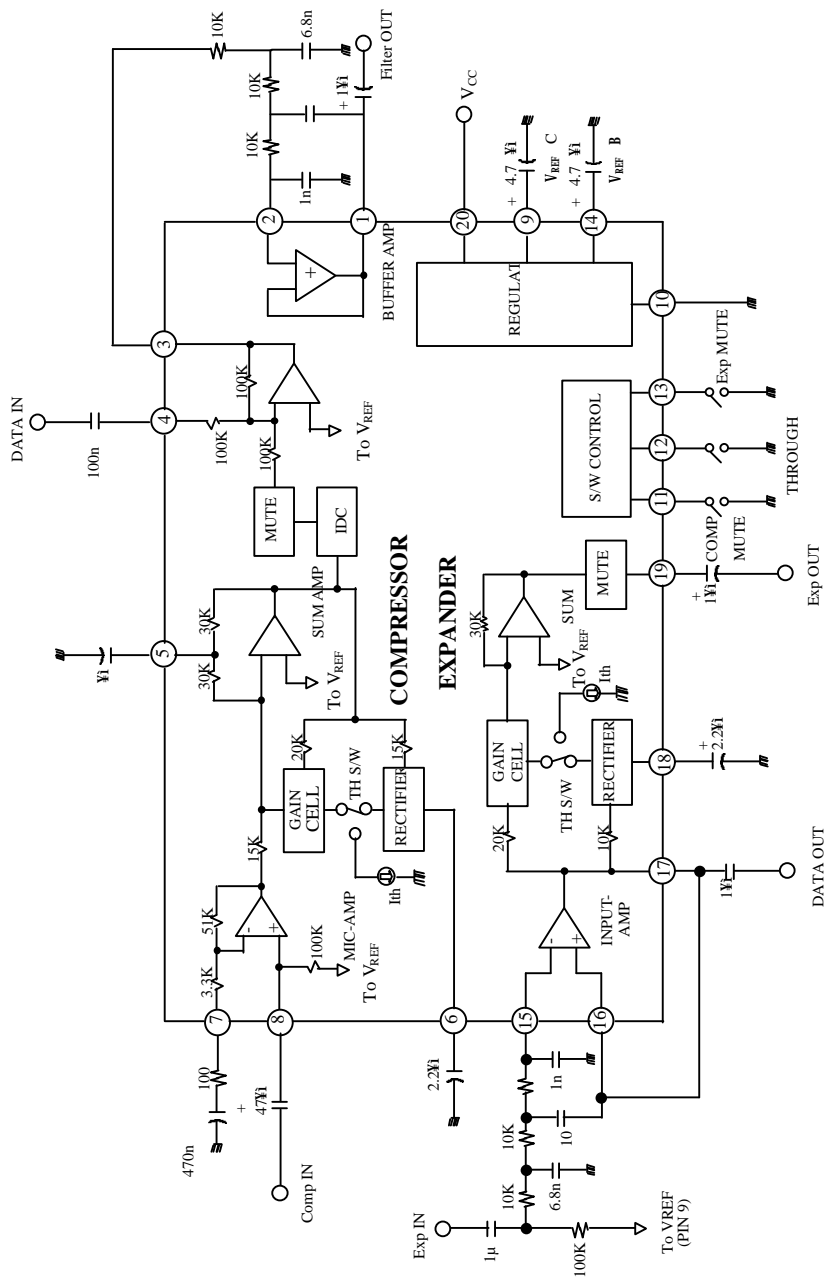



LittleDiode supplies new, hard to find or obsolete electronic components and semiconductors all over the world.

With over two million different components listed you are sure to find the part you need.

Feel free to visit us today at our online store:

**[LittleDiode.com](http://LittleDiode.com)**

Looking forward to providing you with the best possible service.