

# GM6486

## 33 OUTPUT LED DRIVER

### General Description

The GM6486 is a monolithic MOS integrated circuit produced with high voltage CMOS technology. It is available in a 40-pin dual in-line plastic package. A single pin controls the LED display brightness by setting a reference current through a variable resistor connect-ed to VDD or to a separated supply of 13.2V maximum.

### Features

- 33 Output, 15mA Sink Capability
- Current Generator Outputs (No External Resistors Required)
- Continuous Brightness Control
- Serial Data Input-Output
- External Load Input
- Cascade operation capability
- Wide supply voltage range
- TTL compatibility

### Block Diagram

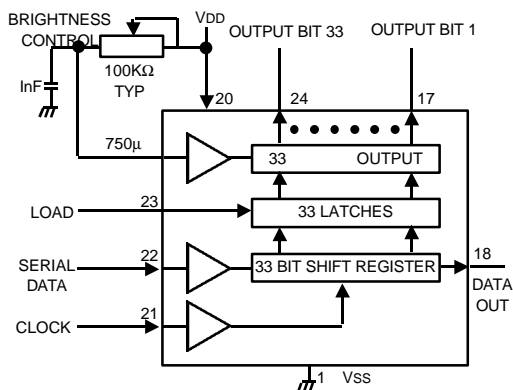

### Application

- Microprocessor Displays
- Industrial control Indicator
- Relay Driver
- Instrumentation Readouts

### Pin Configuration

#### 40 PIN DIP

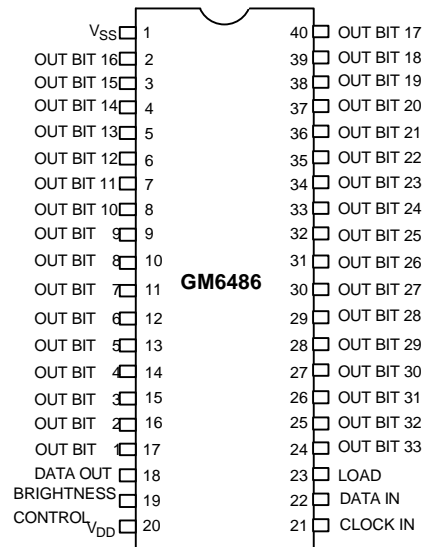

Top View

#### 44 PIN PLCC

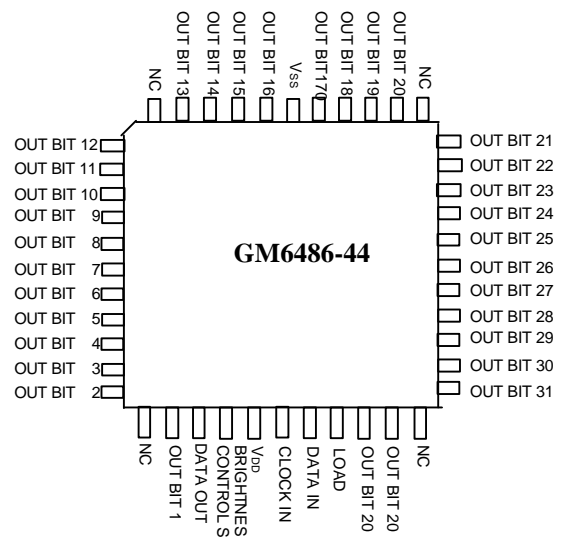

### Absolute Maximum Rating

SYMBOL	PARAMETER	RATINGS	UNIT
$V_{DD}$	Supply Voltage	-0.3 to 15	V
$V_{IN}$	Input Voltage	-0.3 to 15	V
$V_{O(off)}$	Off State Output Voltage	15	V
$I_O$	Output Sink Current	40	mA
$P_{tot}$	Total Package Power Dissipation	1 (at 25 °C)	W
		560 (at 85 °C)	mW
$T_j$	Junction Temperature	150	°C
$T_{op}$	Operating Temperature Range	-25 to 85	°C
$T_{stg}$	Storage Temperature Range	-65 to 150	°C

### Electrical Characteristics

( $T_{amb}$  within operating range,  $V_{DD}=4.75V$  to  $13.2V$   $V_{SS}=0$ , unless otherwise specified)

SYMBOL	PARAMETER	TEST CONDITION	MIN	TYP	MAX	UNIT
$V_{DD}$	Supply Voltage		4.75		13.2	V
$I_{DD}$	Supply Current	$V_{DD}=13.2V$ All Control Inputs at $V_{SS}=0V$		50	1000	$\mu A$
$V_{IL}$	Input Voltage	$\pm 10\mu A$ Input Bias	-0.3		0.8	V
	Logical "0" Level	$4.75 \leq V_{DD} \leq 5.25$	2.2		$V_{DD}$	V
$V_{IH}$	Logical "1" Level	$V_{DD} > 5.25$	$V_{DD} - 2$		$V_{DD}$	V
$I_b$	Brightness input current (Note 1)				0.75	mA
$V_b$	Brightness input voltage (Pin 19)	Input Current= $750\mu A$	3		4.3	V
$V_{O(off)}$	Off State out. Voltage				13.2	V
$I_{OH}$ $I_{OL}$	Output sink current (Note 2)					
	Segment off	$V_o = 3V$			10	$\mu A$
	Segment on	$V_o = 1V$ (Note 3)				
		Bright in = $0\mu A$	0		10	$\mu A$
		Bright in = $100\mu A$	2	2.7	4	mA
		Bright in = $750\mu A$	12	15	25	mA
$I_O$	Maximum Segment Current				40	mA

SYMBOL	PARAMETER	TEST CONDITION	MIN	TYP	MAX	UNIT
O <sub>M</sub>	Output Matching (Note 4)				±20	%
V <sub>OL</sub> V <sub>OH</sub>	Data Output Logical "0" Level Logical "1" Level	I <sub>OUT</sub> = 0.5mA I <sub>OUT</sub> = 100µA	V <sub>SS</sub> 2.4		0.4 V <sub>DD</sub>	V V
f <sub>C</sub> t <sub>th</sub> t <sub>l</sub>	Clock Input Frequency High Time Low Time	(notes 5 and 6)			500	KHz ns ns
t <sub>DS</sub> t <sub>DH</sub>	Data Input Set-up time Hold time		300 300			ns ns
t <sub>DES</sub>	Data Enable Input Set-up time		100			ns

- Note:** 1. With a fixed resistor on the brightness input, some variation in brightness will occur from one device to another.
- Absolute maximum for each output should be limited to 40 mA.
  - The V<sub>o</sub> voltage should be regulated by the user. See figures 6 and 7 for allowable V<sub>o</sub> versus I<sub>o</sub> operation.
  - Output matching is calculated as the percent variation (I<sub>max</sub>+I<sub>min</sub>)/2.
  - AC input waveform specification for test purpose: t<sub>r</sub> ≤ 20ns. t<sub>f</sub> ≤ 20ns. f=500kHz ± 10% duty cycle
  - Clock Input rise and fall times must not exceed 300ns.

## Functional Description

The GM6486 is specifically designed to operate 4 digit displays with minimal interface with the display and the data source. Serial data transfer from the data source to the display driver is accomplished with 3 signals, serial data, clock and load.

The 33 data bits are latched by a positive pulse, thus providing non-multiplexed direct drive to the display. Outputs change only if the serial data bits differ from the previous time. Display brightness is determined by control of the output current of LED drivers. A 1nF capacitor should be connected to brightness control, pin 19, to prevent possible oscillation. A block diagram is shown in figure 1.

The output current is typically 20 times greater than the current into pin 19, which is set by an external variable resistor. There is an internal limiting resistor of 400 Ω nominal value.

Figure 2 and 3 show the input data format. Bit "1" is the first bit into the data input pin and it will appear on pin 17. A logical "1" at the input will turn on the appropriate LED. The LOAD signal latches the 33 bit of the shift registers into the latches. The data out pin allows for cascading the shift registers for more than 33 output drivers. When power is first applied to the chip an internal power ON reset signal is generated which resets all registers and all latches.

The first clock return the chip to its normal operation.

Figure 4 shows the timing relationship between data, clock and load.

A max clock frequency of 0.5MHz is assumed.

For applications where less number of outputs are used, it is possible to either increase the current per output or operate the part at higher than 1V V<sub>o</sub>.

The following equation can be used for calculation.

$$T_j = [(V_o) \cdot (I_{LED}) \cdot (\text{No. of segments}) + (V_{dd} \times 7\text{mA})] (124^\circ\text{C}/\text{W}) + T_{amb}$$

where

T<sub>j</sub> = junction temperature (+150 °C max)    124 °C/W = thermal coefficient of package

V<sub>o</sub> = the voltage at the LED driver outputs    T<sub>amb</sub> = ambient temperature

I<sub>LED</sub> = the LED current

The above equation was used to plot figure 5, 6 and 7.

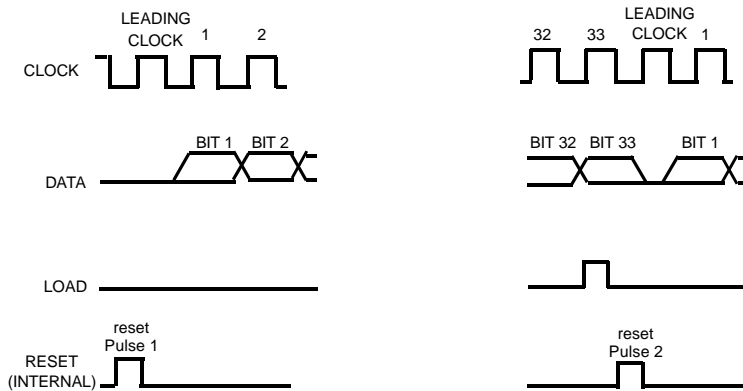

- leading clock is necessary after power on and load signal high.
- reset pulse 1: internal pulse that comes after power on—effective on both shift register and latches
- reset pulse 2: internal pulse that comes load pulse—effective on shift register only.

**Fig. 2. Data Input Format**

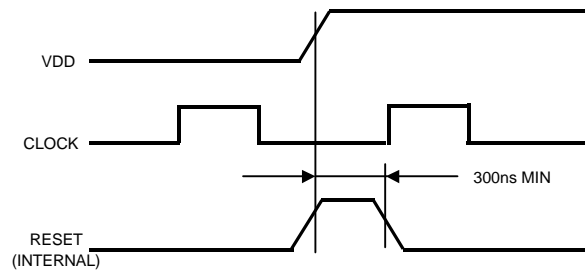

**Fig. 3. Power On Reset**

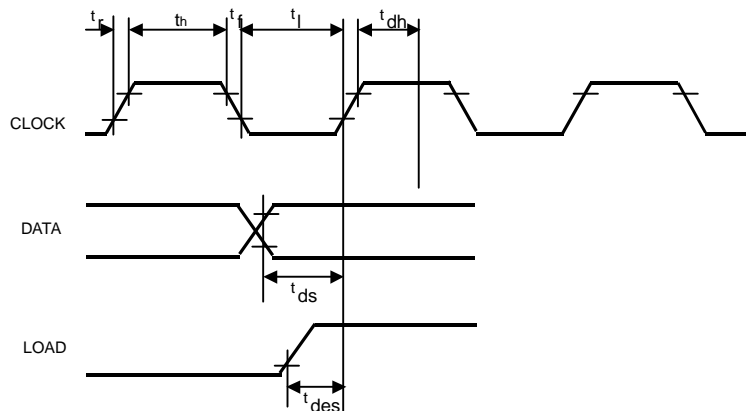

**Fig. 4. Timing Diagram**

Fig. 5

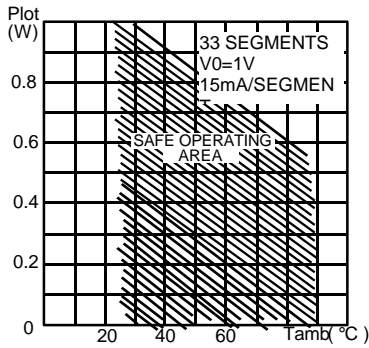

Fig. 6

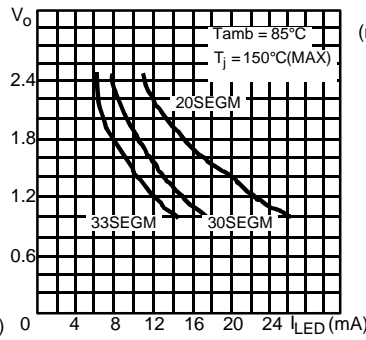
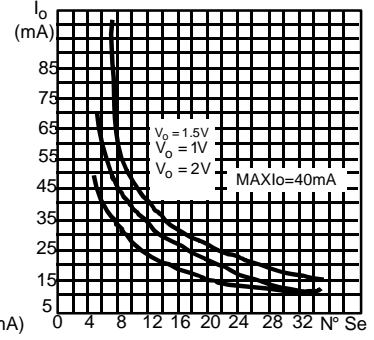
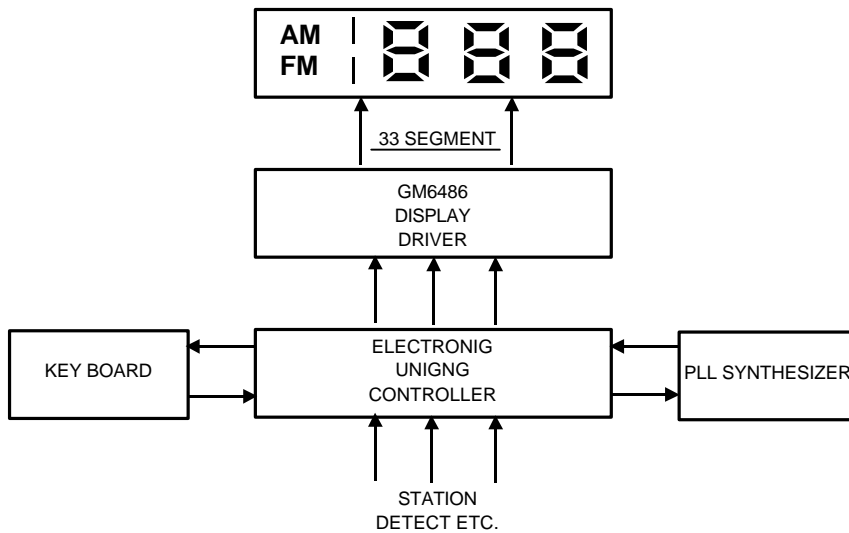

Fig. 7



### Typical Applications

Basic electronically turned Ratio or TV system



**Typical Applications (Continued)**

Duplexing 8 Digits with one GM6486

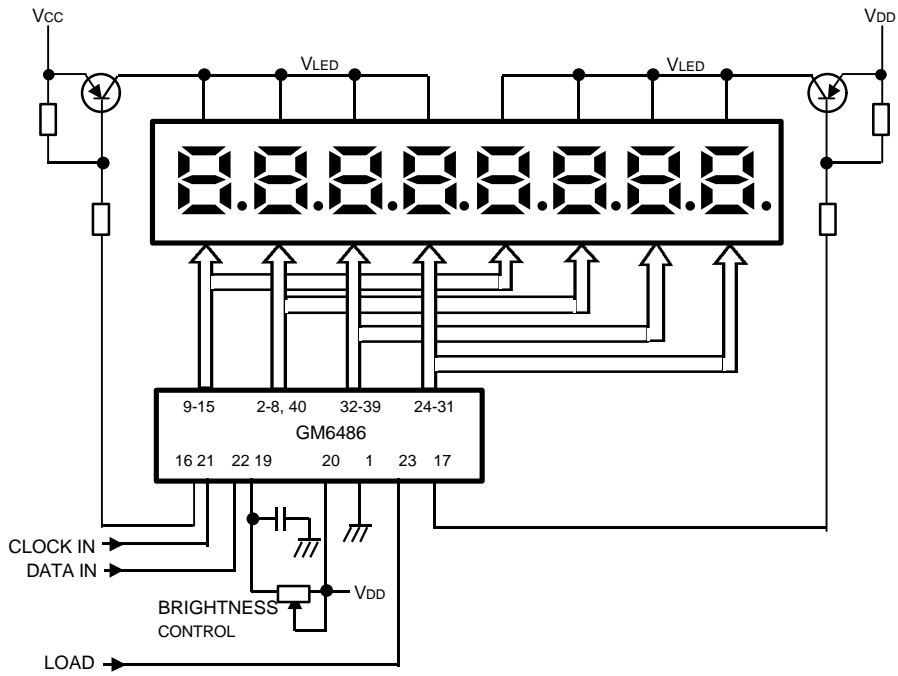

**Power Dissipations of the IC**

The power dissipation of the IC can be limited by using different configuration.

a)

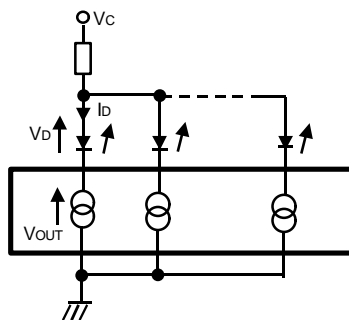

In this application R must be chosen taking into account the worst operating conditions. R is determined by the maximum number of segment activated.

$$R = \frac{V_C - V_{D_{MAX}} - V_{O_{MIN}}}{N_{Max} \cdot I_D}$$

The worst case condition for the device is when roughly half of the maximum number of segments are activated. It must be checked that the total power dissipation does not exceed the absolute maximum ratings.

In critical cases more resistors can be used in conjunction with groups of segments. In this case the current variation in the single resistor is reduced and plot limited.

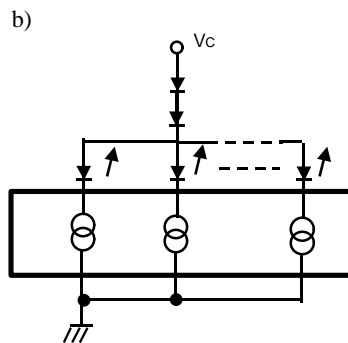

In this configuration the drop on the serial connected diodes is quite stable if the diodes are properly chosen.

The total power dissipation of the ICs is, in first approximation, depending only on the number of segments activated.

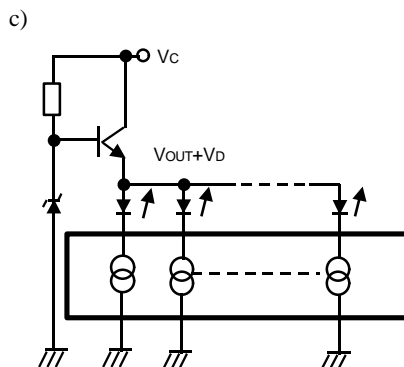

In this configuration  $V_{OUT}+V_D$  is constant. The total power dissipation of the IC depends only the number of segments activated.



LittleDiode supplies new, hard to find or obsolete electronic components and semiconductors all over the world.

With over two million different components listed you are sure to find the part you need.

Feel free to visit us today at our online store:

[LittleDiode.com](http://LittleDiode.com)

Looking forward to providing you with the best possible service.