



# MOTOROLA SEMICONDUCTORS

3501 ED BLUESTEIN BLVD. AUSTIN, TEXAS 78721

## CRT CONTROLLER (CRTC)

The MC6845 CRT controller performs the interface between an MPU and a raster-scan CRT display. It is intended for use in MPU-based controllers for CRT terminals in stand-alone or cluster configurations.

The CRTC is optimized for the hardware/software balance required for maximum flexibility. All keyboard functions, reads, writes, cursor movements, and editing are under processor control. The CRTC provides video timing and refresh memory addressing.

- Useful in Monochrome or Color CRT Applications
- Applications Include "Glass-Teletype," Smart, Programmable, Intelligent CRT Terminals; Video Games; Information Displays
- Alphanumeric, Semi-Graphic, and Full-Graphic Capability
- Fully Programmable Via Processor Data Bus. Timing May Be Generated for Almost Any Alphanumeric Screen Format, e.g., 80 × 24, 72 × 64, 132 × 20
- Single +5 V Supply
- M6800 Compatible Bus Interface
- TTL-Compatible Inputs and Outputs
- Start Address Register Provides Hardware Scroll (by Page or Character)
- Programmable Cursor Register Allows Control of Cursor Format and Blink Rate
- Light Pen Register
- Refresh (Screen) Memory May be Multiplexed Between the CRTC and the MPU Thus Removing the Requirements for Line Buffers or External DMA Devices
- Programmable Interlace or Non-Interlace Scan Modes
- 14-Bit Refresh Address Allows Up to 16K of Refresh Memory for Use in Character or Semi-Graphic Displays
- 5-Bit Row Address Allows Up to 32 Scan-Line Character Blocks
- By Utilizing Both the Refresh Addresses and the Row Addresses, a 512K Address Space is Available for Use in Graphics Systems
- Refresh Addresses are Provided During Retrace, Allowing the CRTC to Provide Row Addresses to Refresh Dynamic RAMs
- Pin Compatible with the MC6835

## ORDERING INFORMATION

Package Type	Frequency (MHz)	Temperature	Order Number
Ceramic L Suffix	1.0	0°C to 70°C	MC6845L
	1.0	-40°C to 85°C	MC6845CL
	1.5	0°C to 70°C	MC68A45L
	1.5	-40°C to 85°C	MC68A45CL
	2.0	0°C to 70°C	MC68B45L
Cerdip S Suffix	1.0	0°C to 70°C	MC6845S
	1.0	-40°C to 85°C	MC6845CS
	1.5	0°C to 70°C	MC68A45S
	1.5	-40°C to 85°C	MC68A45CS
	2.0	0°C to 70°C	MC68B45S
Plastic P Suffix	1.0	0°C to 70°C	MC6845P
	1.0	-40°C to 85°C	MC6845CP
	1.5	0°C to 70°C	MC68A45P
	1.5	-40°C to 85°C	MC68A45CP
	2.0	0°C to 70°C	MC68B45P

# MC6845

**MOS**  
(N-CHANNEL, SILICON-GATE)

**CRT CONTROLLER  
(CRTC)**

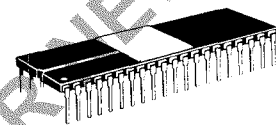

**L SUFFIX**  
CERAMIC PACKAGE  
CASE 715

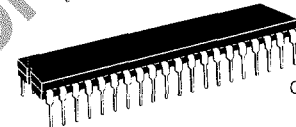

**S SUFFIX**  
CERDIP PACKAGE  
CASE 734

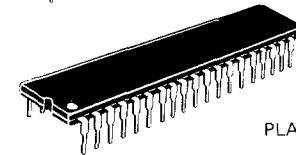

**P SUFFIX**  
PLASTIC PACKAGE  
CASE 711

## PIN ASSIGNMENT

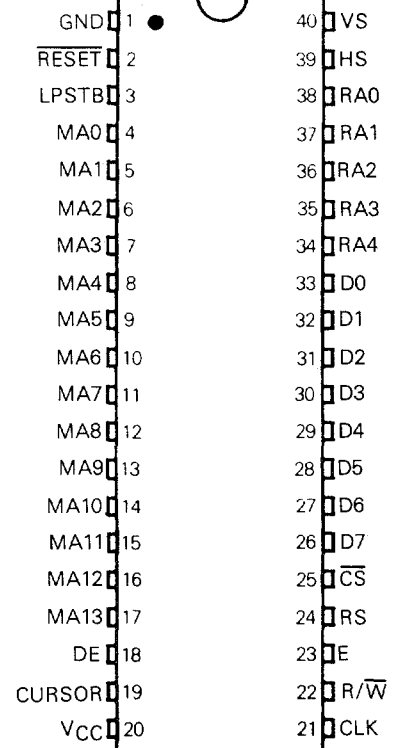
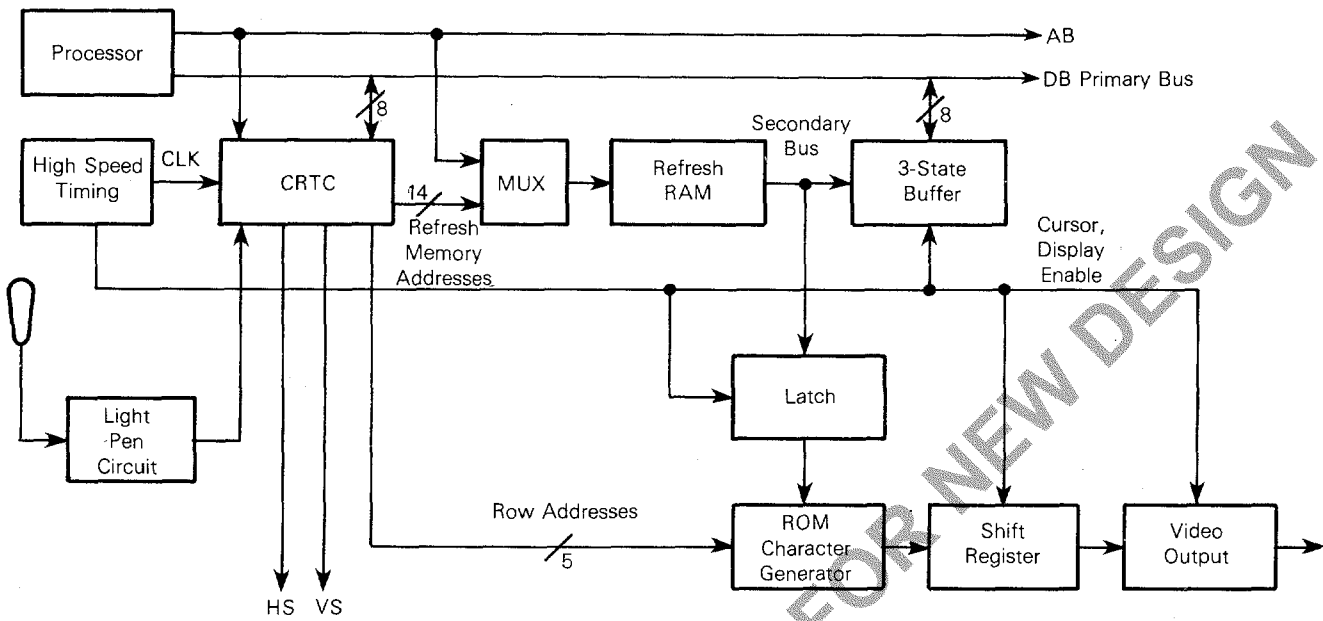

FIGURE 1 — TYPICAL CRT CONTROLLER APPLICATION



**MAXIMUM RATINGS**

Rating	Symbol	Value	Unit
Supply Voltage	V <sub>CC</sub>	-0.3 to +7.0	V
Input Voltage	V <sub>in</sub>	-0.3 to +7.0	V
Operating Temperature Range MC6845, MC68A45, MC68B45 MC6845C, MC68A45C	T <sub>A</sub>	T <sub>L</sub> to T <sub>H</sub> 0 to 70 -40 to +85	°C
Storage Temperature Range	T <sub>stg</sub>	-55 to +150	°C

**THERMAL CHARACTERISTICS**

Characteristic	Symbol	Value	Rating
Thermal Resistance Plastic Package Cerdip Package Ceramic Package	θ <sub>JA</sub>	100 60 50	°C/W

The device contains circuitry to protect the inputs against damage due to high static voltages or electric fields; however, it is advised that normal precautions be taken to avoid application of any voltage higher than maximum rated voltages to this high-impedance circuit. For proper operation it is recommended that V<sub>in</sub> and V<sub>out</sub> be constrained to the range V<sub>SS</sub> ≤ (V<sub>in</sub> or V<sub>out</sub>) ≤ V<sub>CC</sub>.

**RECOMMENDED OPERATING CONDITIONS**

Characteristics	Symbol	Min	Typ	Max	Unit
Supply Voltage	V <sub>CC</sub>	4.75	5.0	5.25	V
Input Low Voltage	V <sub>IL</sub>	-0.3	-	0.8	V
Input High Voltage	V <sub>IH</sub>	2.0	-	V <sub>CC</sub>	V



## POWER CONSIDERATIONS

The average chip-junction temperature,  $T_J$ , in  $^{\circ}\text{C}$  can be obtained from:

$$T_J = T_A + (P_D \cdot \theta_{JA}) \quad (1)$$

Where:

- $T_A$   $\equiv$  Ambient Temperature,  $^{\circ}\text{C}$
- $\theta_{JA}$   $\equiv$  Package Thermal Resistance, Junction-to-Ambient,  $^{\circ}\text{C}/\text{W}$
- $P_D$   $\equiv$   $P_{INT} + P_{PORT}$
- $P_{INT}$   $\equiv$   $I_{CC} \times V_{CC}$ , Watts — Chip Internal Power
- $P_{PORT}$   $\equiv$  Port Power Dissipation, Watts — User Determined

For most applications  $P_{PORT} \ll P_{INT}$  and can be neglected.  $P_{PORT}$  may become significant if the device is configured to drive Darlington bases or sink LED loads.

An approximate relationship between  $P_D$  and  $T_J$  (if  $P_{PORT}$  is neglected) is:

$$P_D = K + (T_J + 273^{\circ}\text{C}) \quad (2)$$

Solving equations 1 and 2 for K gives:

$$K = P_D \cdot (T_A + 273^{\circ}\text{C}) + \theta_{JA} \cdot P_D^2 \quad (3)$$

Where K is a constant pertaining to the particular part. K can be determined from equation 3 by measuring  $P_D$  (at equilibrium) for a known  $T_A$ . Using this value of K the values of  $P_D$  and  $T_J$  can be obtained by solving equations (1) and (2) iteratively for any value of  $T_A$ .

**DC ELECTRICAL CHARACTERISTICS** ( $V_{CC} = 5.0 \text{ Vdc} \pm 5\%$ ,  $V_{SS} = 0$ ,  $T_A = 0$  to  $70^{\circ}\text{C}$  unless otherwise noted, see Figures 2-4)

Characteristic	Symbol	Min	Typ	Max	Unit
Input High Voltage	$V_{IH}$	2.0	—	$V_{CC}$	V
Input Low Voltage	$V_{IL}$	-0.3	—	0.8	V
Input Leakage Current	$I_{in}$	—	0.1	2.5	$\mu\text{A}$
Hi-Z State Input Current ( $V_{CC} = 5.25 \text{ V}$ ) ( $V_{in} = 0.4$ to $2.4 \text{ V}$ )	$I_{TSI}$	-10	—	10	$\mu\text{A}$
Output High Voltage ( $I_{Load} = -205 \mu\text{A}$ ) ( $I_{Load} = -100 \mu\text{A}$ )	D0-D7 Other Outputs $V_{OH}$	2.4 2.4	3.0 3.0	— —	V
Output Low Voltage ( $I_{Load} = 1.6 \text{ mA}$ )	$V_{OL}$	—	0.3	0.4	V
Internal Power Dissipation (Measured at $T_A = 0^{\circ}\text{C}$ )	$P_{INT}$	—	600	750	mW
Input Capacitance	D0-D7 All Others $C_{in}$	— —	— —	12.5 10	pF
Output Capacitance	All Outputs $C_{out}$	—	—	10	pF



**BUS TIMING CHARACTERISTICS** (See Notes 1 and 2) (Reference Figures 2 and 3)

Ident. Number	Characteristic	Symbol	MC6845		MC68A45		MC68B45		Unit
			Min	Max	Min	Max	Min	Max	
1	Cycle Time	$t_{cyc}$	1.0	10**	0.67	10	0.5	10**	$\mu s$
2	Pulse Width, E Low	PWEL	430	—	280	—	210	—	ns
3	Pulse Width, E High	PWEH	450	—	280	—	220	—	ns
4	Clock Rise and Fall Time	$t_r, t_f$	—	25	—	25	—	20	ns
9	Address Hold Time (RS)	$t_{AH}$	10	—	10	—	10	—	ns
13	RS Setup Time Before E	$t_{AS}$	80	—	60	—	40	—	ns
14	R/W and $\overline{CS}$ Setup Time Before E	$t_{CS}$	80	—	60	—	40	—	ns
15	R/W and $\overline{CS}$ Hold Time	$t_{CH}$	10	—	10	—	10	—	ns
18	Read Data Hold Time	$t_{DHR}$	20	50*	20	50*	20	50*	ns
21	Write Data Hold Time	$t_{DHW}$	10	—	10	—	10	—	ns
30	Peripheral Output Data Delay Time	$t_{DDR}$	—	290	—	180	0	150	ns
31	Peripheral Input Data Setup Time	$t_{DSW}$	165	—	80	—	60	—	ns

\* The data bus output buffers are no longer sourcing or sinking current by  $t_{DHR}$  maximum (high impedance).

\*\* The E clock may be low for extended periods provided the CLK input is active.

FIGURE 2 — MC6845 BUS TIMING

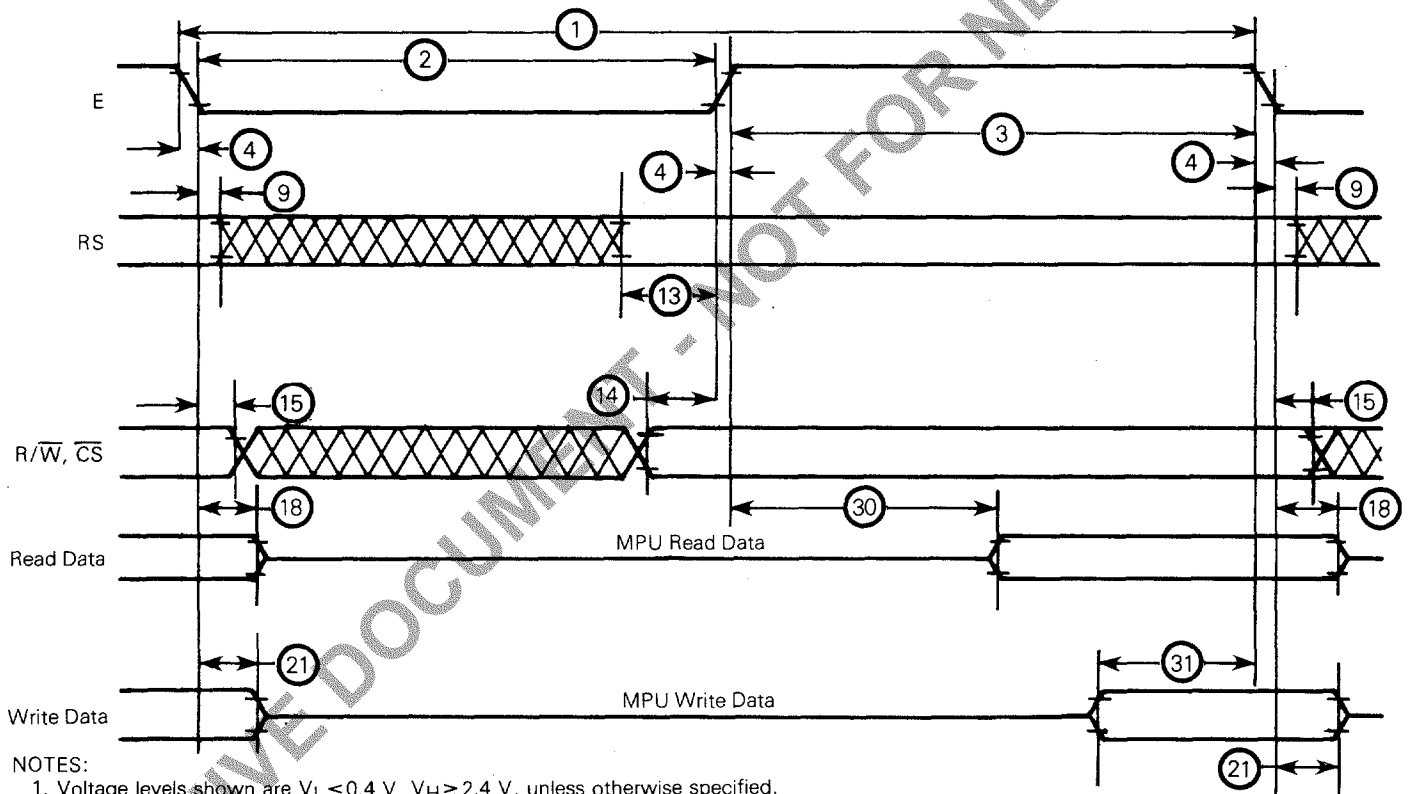

NOTES:

1. Voltage levels shown are  $V_L \leq 0.4$  V,  $V_H \geq 2.4$  V, unless otherwise specified.
2. Measurement points shown are 0.8 V and 2.0 V, unless otherwise specified.

FIGURE 3 — BUS TIMING TEST LOAD

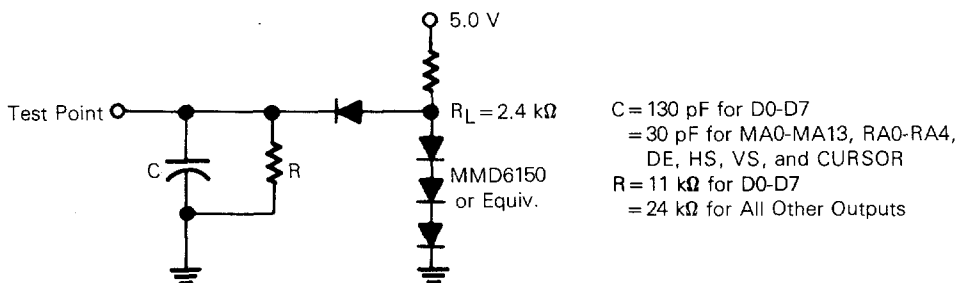

the dots. As "x" and "y" get larger a more detailed character may be created. Two common dot matrices are  $5 \times 7$  and  $7 \times 9$ . Many variations of these standards will allow Chinese, Japanese, or Arabic letters instead of English. Since characters require some space between them, a character block larger than the character is typically used, as shown in Figure 8. The figure also shows the corresponding timing and levels for a video signal that would generate the characters.

Referring to Figure 1, the CRT controller generates the refresh addresses (MA0-MA13), row addresses (RA0-RA4), and the video timing (vertical sync — VS, horizontal sync — HS, and display enable — DE). Other functions include an internal cursor register which generates a cursor output when its contents compare to the current refresh address. A light pen strobe input signal allows capture of the refresh address in an internal light pen register.

All timing in the CRTC is derived from the CLK input. In alphanumeric terminals, this signal is the character rate. The video rate or "dot" clock is externally divided by high-speed logic (TTL) to generate the CLK input. The high-speed logic must also generate the timing and control signals necessary for the shift register, latch, and MUX control.

The processor communicates with the CRTC through an 8-bit data bus by reading or writing into the 19 registers.

The refresh memory address is multiplexed between the processor and the CRTC. Data appears on a secondary bus separate from the processor's bus. The secondary data bus concept in no way precludes using the refresh RAM for other purposes. It looks like any other RAM to the processor. A number of approaches are possible for solving contentions for the refresh memory:

1. Processor always gets priority. (Generally, "hash" occurs as MPU and CRTC clocks are not synchronized.)
2. Processor gets priority access anytime, but can be synchronized by an interrupt to perform accesses only during horizontal and vertical retrace times.
3. Synchronize the processor with memory wait cycles (states).
4. Synchronize the processor to the character rate as shown in Figure 9. The M6800 processor family works very well in this configuration as constant cycle lengths are present. This method provides no overhead for the processor as there is never a contention for a memory access. All accesses are transparent.

FIGURE 8 — CHARACTER DISPLAY ON THE SCREEN AND VIDEO SIGNAL

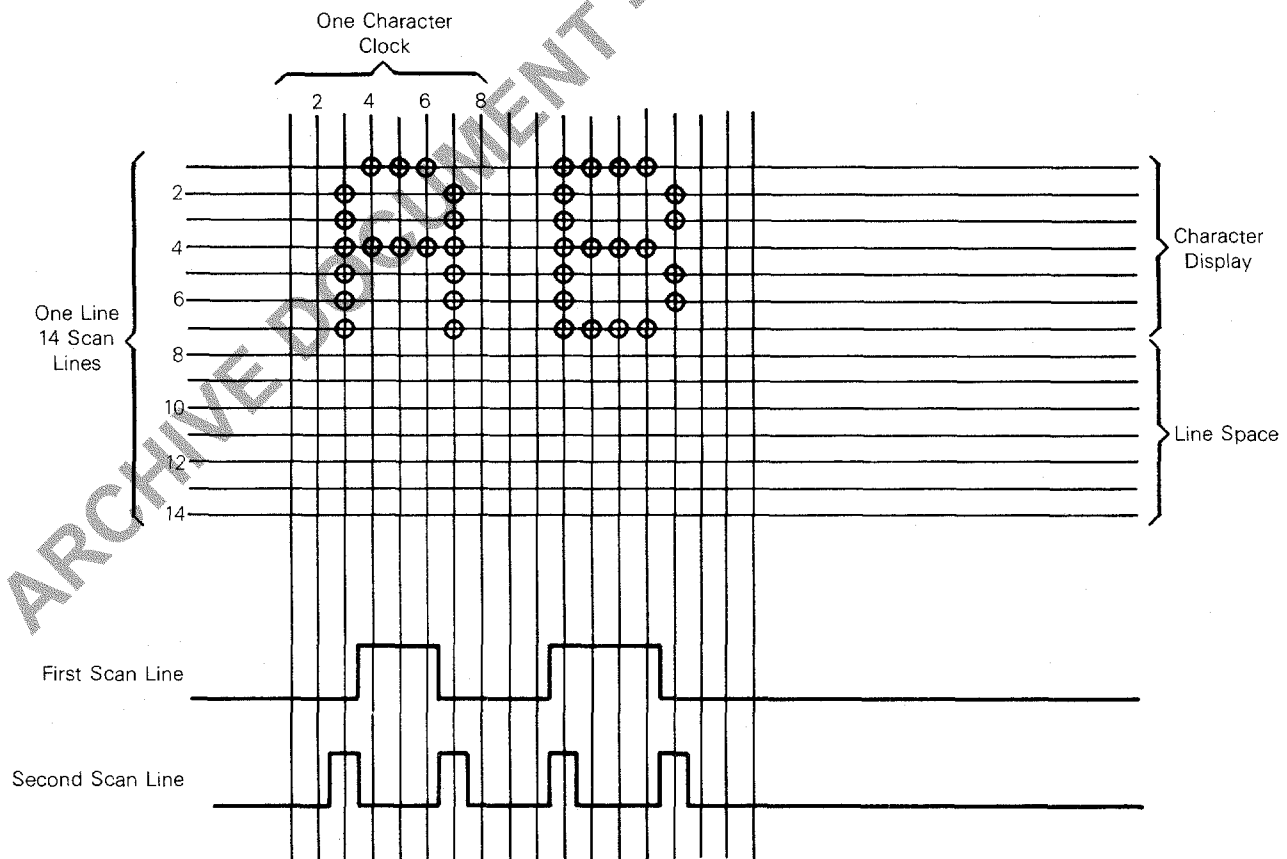
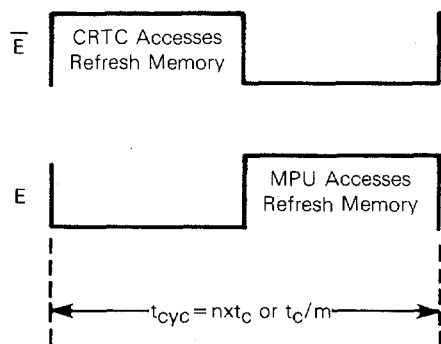

FIGURE 9 — TRANSPARENT REFRESH MEMORY  
CONFIGURATION TIMING USING M6800 FAMILY MPU



Where: m, n are integers;  $t_c$  is character period

## PIN DESCRIPTION

### PROCESSOR INTERFACE

The CRTC interfaces to a processor bus on the bidirectional data bus (D0-D7) using  $\overline{CS}$ , RS, E, and R/W for control signals.

**Data Bus (D0-D7)** — The bidirectional data lines (D0-D7) allow data transfers between the internal CRTC register file and the processor. Data bus output drivers are in the high-impedance state until the processor performs a CRTC read operation.

**Enable (E)** — The enable signal is a high-impedance TTL/MOS compatible input which enables the data bus input/output buffers and clocks data to and from the CRTC. This signal is usually derived from the processor clock. The high-to-low transition is the active edge.

**Chip Select ( $\overline{CS}$ )** — The  $\overline{CS}$  line is a high-impedance TTL/MOS compatible input which selects the CRTC, when low, to read or write to the internal register file. This signal should only be active when there is a valid stable address being decoded from the processor.

**Register Select (RS)** — The RS line is a high-impedance TTL/MOS compatible input which selects either the address register (RS=0) or one of the data register (RS=1) or the internal register file.

**Read/Write (R/W)** — The R/W line is a high-impedance TTL/MOS compatible input which determines whether the internal register file gets written or read. A write is defined as a low level.

### CRT CONTROL

The CRTC provides horizontal sync (HS), vertical sync (VS), and display enable (DE) signals.

#### NOTE

Care should be exercised when interfacing to CRT monitors, as many monitors claiming to be "TTL compatible" have transistor input circuits which require the CRTC or TTL devices buffering signals from the CRTC/video circuits to exceed the maximum-rated drive currents.

**Vertical Sync (VS) and Horizontal Sync (HS)** — These TTL-compatible outputs are active high signals which drive the monitor directly or are fed to the video processing circuitry to generate a composite video signal. The VS signal determines the vertical position of the displayed text while the HS signal determines the horizontal position of the displayed text.

**Display Enable (DE)** — This TTL-compatible output is an active high signal which indicates the CRTC is providing addressing in the active display area.

### REFRESH MEMORY/CHARACTER GENERATOR ADDRESSING

The CRTC provides memory addresses (MA0-MA13) to scan the refresh RAM. Row addresses (RA0-RA4) are also provided for use with character generator ROMs. In a graphics system, both the memory addresses and the row addresses would be used to scan the refresh RAM. Both the memory addresses and the row addresses continue to run during vertical retrace thus allowing the CRTC to provide the refresh addresses required to refresh dynamic RAMs.

**Refresh Memory Addresses (MA0-MA13)** — These 14 outputs are used to refresh the CRT screen with pages of data located within a 16K block of refresh memory. These outputs are capable of driving one standard TTL load and 30 pF.

**Row Addresses (RA0-RA4)** — These five outputs from the internal row address counter are used to address the character generator ROM. These outputs are capable of driving one standard TTL load and 30 pF.

### OTHER PINS

**Cursor** — This TTL-compatible output indicates a valid cursor address to external video processing logic. It is an active high signal.

**Clock (CLK)** — The CLK is a TTL/MOS-compatible input used to synchronize all CRT functions except for the processor interface. An external dot counter is used to derive this signal which is usually the character rate in an alphanumeric CRT. The active transition is high-to-low.



**Light Pen Strobe (LPSTB)** — A low-to-high transition on this high-impedance TTL/MOS-compatible input latches the current Refresh Address in the light pen register. The latching of the refresh address is internally synchronized to the character clock (CLK).

**VCC and VSS** — These inputs supply +5 Vdc  $\pm 5\%$  to the CRTC.

**RESET** — The  $\overline{\text{RESET}}$  input is used to reset the CRTC. A low level on the  $\overline{\text{RESET}}$  input forces the CRTC into the following state:

- All counters in the CRTC are cleared and the device stops the display operation.
- All the outputs are driven low.

#### NOTE

The horizontal sync output is not defined until after R2 is programmed.

- The control registers of the CRTC are not affected and remain unchanged.

Functionality of  $\overline{\text{RESET}}$  differs from that of other M6800 parts in the following functions:

### CRTC DESCRIPTION

The CRTC consists of programmable horizontal and vertical timing generators, programmable linear address register, programmable cursor logic, light pen capture register, and control circuitry for interface to a processor bus. A block diagram of the CRTC is shown in Figure 10.

All CRTC timing is derived from the CLK, usually the output of an external dot rate counter. Coincidence (CO) circuits continuously compare counter contents to the contents of the programmable register file, R0-R17. For horizontal timing generation, comparisons result in: 1) horizontal sync pulse (HS) of a frequency, position, and width determined by the registers; 2) horizontal display signal of a frequency, position, and duration determined by the registers.

The horizontal counter produces H clock which drives the scan line counter and vertical control. The contents of the raster counter are continuously compared to the maximum scan line address register. A coincidence resets the raster counter and clocks the vertical counter.

Comparisons of vertical counter contents and vertical registers result in: 1) vertical sync pulse (VS) of a frequency and position determined by the registers; 2) vertical display of a frequency and position determined by the registers.

The vertical control logic has other functions.

- Generate row selects, RA0-RA4, from the raster count for the corresponding interlace or non-interlace modes.
- Extend the number of scan lines in the vertical total by the amount programmed in the vertical total adjust register.

The linear address generator is driven by the CLK and locates the relative positions of characters in memory with their positions on the screen. Fourteen lines, MA0-MA13, are available for addressing up to four pages of 4K characters, eight pages of 2K characters, etc. Using the start address register, hardware scrolling through 16K characters is possible. The linear address generator repeats the same sequence of addresses for each scan line of a character row.

The cursor logic determines the cursor location, size, and blink rate on the screen. All are programmable.

The light pen strobe going high causes the current contents of the address counter to be latched in the light pen

- The  $\overline{\text{RESET}}$  input and the LPSTB input are encoded as shown in Table 1.

TABLE 1 — CRTC OPERATING MODE

RESET	LPSTB	Operating Mode
0	0	Reset
0	1	Test Mode
1	0	Normal Mode
1	1	Normal Mode

The test mode configures the memory addresses as two independent 7-bit counters to minimize test time.

- After  $\overline{\text{RESET}}$  has gone low and (LPSTB=0), MA0-MA13 and RA0-RA4 will be driven low on the falling edge of CLK.  $\overline{\text{RESET}}$  must remain low for at least one cycle of the character clock (CLK).
- The CRTC resumes the display operation immediately after the release of  $\overline{\text{RESET}}$ . DE and the CURSOR are not active until after the first frame has been displayed.

register. The contents of the light pen register are subsequently read by the processor.

Internal CRTC registers are programmed by the processor through the data bus, D0-D7, and the control signals — R/W,  $\overline{\text{CS}}$ , RS, and E.

### REGISTER FILE DESCRIPTIONS

The nineteen registers of the CRTC may be accessed through the data bus. Only two memory locations are required as one location is used as a pointer to address one of the remaining eighteen registers. These eighteen registers control horizontal timing, vertical timing, interlace operation, row address operation, and define the cursor, cursor address, start address, and light pen register. The register addresses and sizes are shown in Table 2.

#### ADDRESS REGISTER

The address register is a 5-bit write-only register used as an "indirect" or "pointer" register. It contains the address of one of the other eighteen registers. When both RS and  $\overline{\text{CS}}$  are low, the address register is selected. When  $\overline{\text{CS}}$  is low and RS is high, the register pointed to by the address register is selected.

#### TIMING REGISTERS R0-R9

Figure 11 shows the visible display area of a typical CRT monitor giving the point of reference for horizontal registers as the left-most displayed character position. Horizontal registers are programmed in character clock time units with respect to the reference as shown in Figure 12. The point of reference for the vertical registers is the top character position displayed. Vertical registers are programmed in scan line times with respect to the reference as shown in Figure 13.

**Horizontal Total Register (R0)** — This 8-bit write-only register determines the horizontal sync (HS) frequency by defining the HS period in character times. It is the total of the displayed characters plus the non-displayed character times (retrace) minus one.



FIGURE 10 — CRTIC BLOCK DIAGRAM

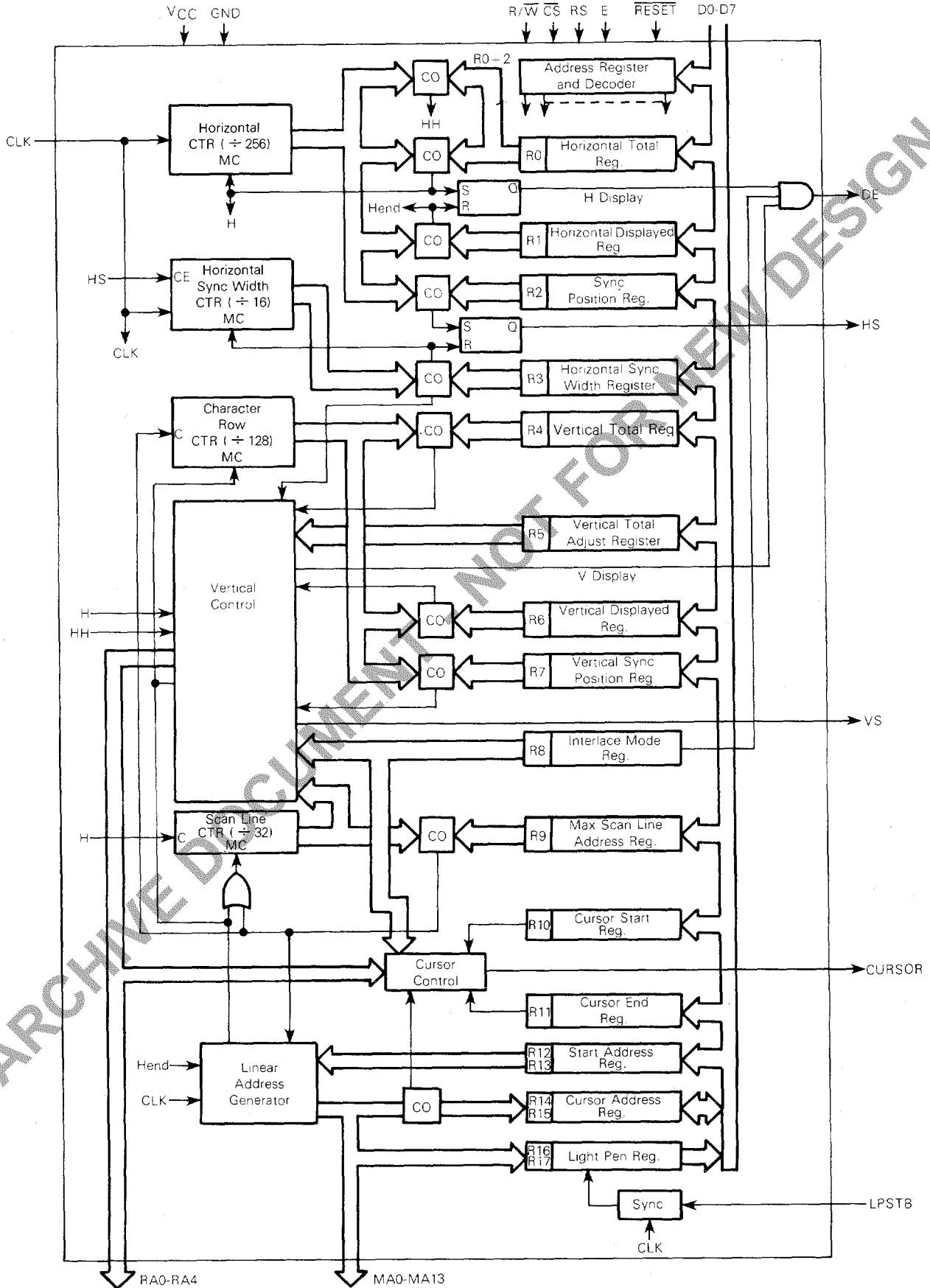

TABLE 2 — CRTC INTERNAL REGISTER ASSIGNMENT

CS	RS	Address Register					Register #	Register File	Program Unit	Read	Write	Number of Bits										
		4	3	2	1	0						7	6	5	4	3	2	1	0			
1	X	X	X	X	X	X	X	—	—	—	—	/	/	/	/	/	/	/	/	/	/	
0	0	X	X	X	X	X	AR	Address Register	—	No	Yes	/	/	/	/	/	/	/	/	/	/	
0	1	0	0	0	0	0	R0	Horizontal Total	Char.	No	Yes	/	/	/	/	/	/	/	/	/	/	
0	1	0	0	0	0	1	R1	Horizontal Displayed	Char.	No	Yes	/	/	/	/	/	/	/	/	/	/	
0	1	0	0	0	1	0	R2	H. Sync Position	Char.	No	Yes	/	/	/	/	/	/	/	/	/	/	
0	1	0	0	0	1	1	R3	Sync Width	—	No	Yes	/	/	/	/	/	/	/	/	/	/	
0	1	0	0	1	0	0	R4	Vertical Total	Char. Row	No	Yes	/	/	/	/	/	/	/	/	/	/	
0	1	0	0	1	0	1	R5	V. Total Adjust	Scan Line	No	Yes	/	/	/	/	/	/	/	/	/	/	
0	1	0	0	1	1	0	R6	Vertical Displayed	Char. Row	No	Yes	/	/	/	/	/	/	/	/	/	/	
0	1	0	0	1	1	1	R7	V. Sync Position	Char. Row	No	Yes	/	/	/	/	/	/	/	/	/	/	
0	1	0	1	0	0	0	R8	Interlace Mode and Skew	Note 1	No	Yes	/	/	/	/	/	/	/	/	/	/	
0	1	0	1	0	0	1	R9	Max Scan Line Address	Scan Line	No	Yes	/	/	/	/	/	/	/	/	/	/	
0	1	0	1	0	1	0	R10	Cursor Start	Scan Line	No	Yes	B	P								(Note 2)	
0	1	0	1	0	1	1	R11	Cursor End	Scan Line	No	Yes	/	/	/	/	/	/	/	/	/	/	/
0	1	0	1	1	0	0	R12	Start Address (H)	—	No	Yes	0	0									
0	1	0	1	1	0	1	R13	Start Address (L)	—	No	Yes	/	/	/	/	/	/	/	/	/	/	/
0	1	0	1	1	1	0	R14	Cursor (H)	—	Yes	Yes	0	0									
0	1	0	1	1	1	1	R15	Cursor (L)	—	Yes	Yes	/	/	/	/	/	/	/	/	/	/	/
0	1	1	0	0	0	0	R16	Light Pen (H)	—	Yes	No	0	0									
0	1	1	0	0	0	1	R17	Light Pen (L)	—	Yes	No	/	/	/	/	/	/	/	/	/	/	/

NOTES:

1. The interlace is shown in Table 3.
2. Bit 5 of the cursor start raster register is used for blink period control, and bit 6 is used to select blink or no-blink.

FIGURE 11 — ILLUSTRATION OF THE CRT SCREEN FORMAT

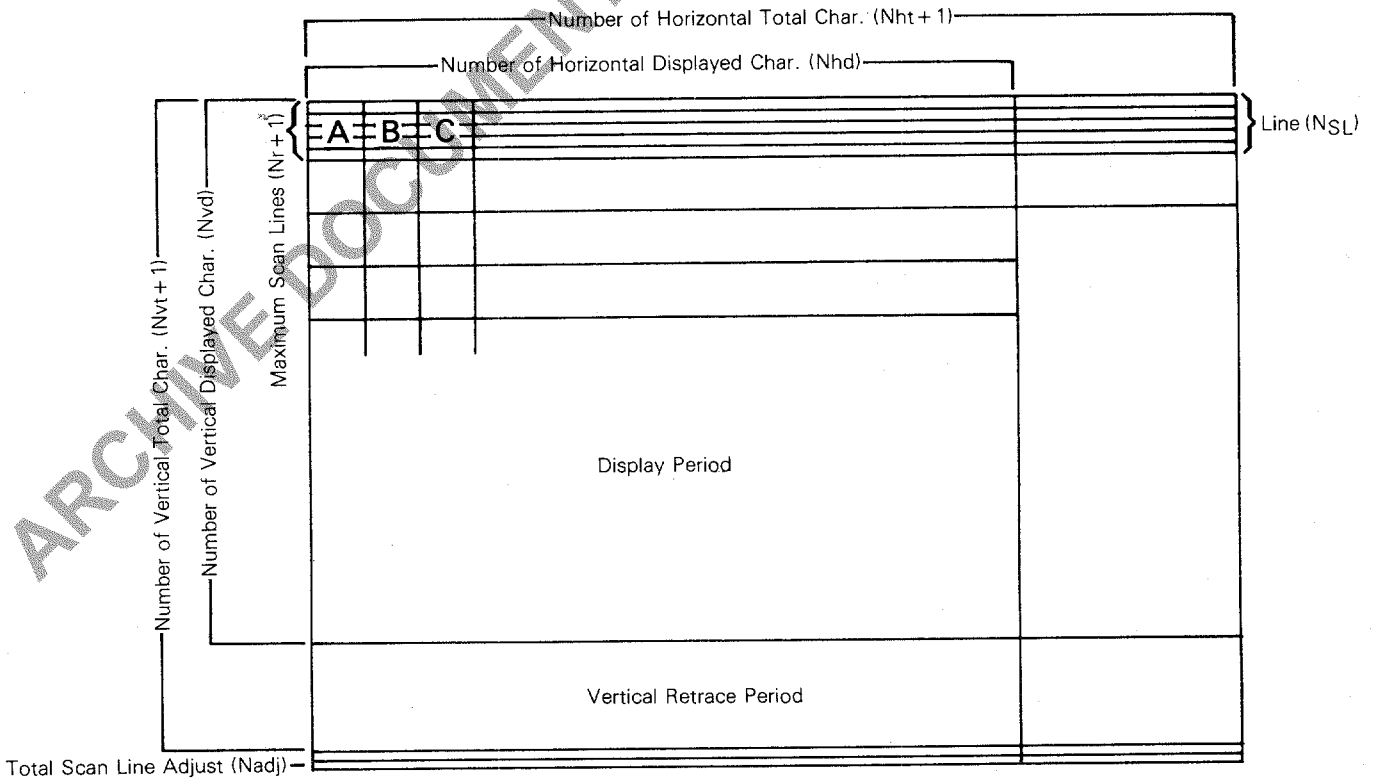

NOTE 1: Timing values are described in Table 5.



**Horizontal Displayed Register (R1)** — This 8-bit write-only register determines the number of displayed characters per line. Any 8-bit number may be programmed as long as the contents of R0 are greater than the contents of R1.

**Horizontal Sync Position Register (R2)** — This 8-bit write-only register controls the HS position. The horizontal sync position defines the horizontal sync delay (front porch) and the horizontal scan delay (back porch). When the programmed value of this register is increased, the display on the CRT screen is shifted to the left. When the programmed value is decreased the display is shifted to the right. Any 8-bit number may be programmed as long as the sum of the contents of R2 and R3 are less than the contents of R0. R2 must be greater than R1.

**Sync Width Register (R3)** — This 8-bit write-only register determines the width of the horizontal sync (HS) pulse. The vertical sync pulse width is fixed at 16 scan-line times.

The HS pulse width may be programmed from 1-to-15 character clock periods thus allowing compatibility with the HS pulse width specifications of many different monitors. If zero is written into this register then no HS is provided.

**Horizontal Timing Summary (Figure 12)** — The difference between R0 and R1 is the horizontal blanking interval. This interval in the horizontal scan period allows the beam to return (retrace) to the left side of the screen. The retrace time is determined by the monitor's horizontal scan components. Retrace time is less than the horizontal blanking interval. A good rule of thumb is to make the horizontal blanking about 20% of the total horizontal scanning period for a CRT. In inexpensive TV receivers, the beam overscans the display screen so that aging of parts does not result in underscanning. Because of this, the retrace time should be about one third the horizontal scanning period. The horizontal sync delay, HS pulse width, and horizontal scan delay are typically programmed with a 1:2:2 ratio.

**Vertical Total Register (R4) and Vertical Total Adjust Register (R5)** — The frequency of VS is determined by both R4 and R5. The calculated number of character row times is usually an integer plus a fraction to get exactly a 50 or 60 Hz vertical refresh rate. The integer number of character row times minus one is programmed in the 7-bit write-only vertical total register (R4). The fraction of character line times is programmed in the 5-bit write-only vertical total adjust register (R5) as the number of scan lines required.

**Vertical Displayed Register (R6)** — This 7-bit write-only register specifies the number of displayed character rows on the CRT screen, and is programmed in character row times. Any number smaller than the contents of R4 may be programmed into R6.

**Vertical Sync Position (R7)** — This 7-bit write-only register controls the position of vertical sync with respect to the reference. It is programmed in character row times. When the programmed value of this register is increased, the display position of the CRT screen is shifted up. When the programmed value is decreased the display position is shifted down. Any number equal to or less than the vertical total (R4) and greater than or equal to the vertical displayed (R6) may be used.

**Interlace Mode and Skew Register (R8)** — The MC6845 only allows control of the interlace modes as programmed by the low order two bits of this write-only register. Table 3 shows the interlace modes available to the user. These modes are selected using the two low order bits of this 6-bit write-only register.

TABLE 3 — INTERLACE MODE REGISTER

Bit 1	Bit 0	Mode
0	0	Normal Sync Mode (Non-Interlace)
1	0	Interlace Sync Mode
0	1	Interlace Sync and Video Mode
1	1	Interlace Sync and Video Mode

In the normal sync mode (non-interlace) only one field is available as shown in Figures 6 and 14a. Each scan line is refreshed at the VS frequency (e.g., 50 or 60 Hz).

Two interlace modes are available as shown in Figures 7, 14b, and 14c. The frame time is divided between even and odd alternating fields. The horizontal and vertical timing relationship (VS delayed by one half scan line time) results in the displacement of scan lines in the odd field with respect to the even field.

In the interlace sync mode the same information is painted in both fields as shown in Figure 14b. This is a useful mode for filling in a character to enhance readability.

In the interlace sync and video mode, shown in Figure 14c, alternating lines of the character are displayed in the even field and the odd field. This effectively doubles the given bandwidth of the CRT monitor.

Care must be taken when using either interlace mode to avoid an apparent flicker effect. This flicker effect is due to the doubling of the refresh time for all scan lines since each field is displayed alternately and may be minimized with proper monitor design (e.g., longer persistence phosphors).

In addition, there are restrictions on the programming of the CRTC registers for interlace operation:

1. The horizontal total register value, R0, must be odd (i.e., an even number of character times).
2. For interlace sync and video mode only, the maximum scan-line address, R9, must be odd (i.e., an even number of scan lines).
3. For interlace sync and video mode only, the number (Nvd) programmed into the vertical display register (R6) must be one half the actual number required. The even numbered scan lines are displayed in the even field and the odd numbered scan lines are displayed in the odd field.
4. For interlace sync and video mode only, the cursor start register (R10) and cursor end register (R11) must both be even or both odd depending on which field the cursor is to be displayed in. A full block cursor will be displayed in both the even and the odd field when the cursor end register (R11) is programmed to a value greater than the value in the maximum scan line address register (R9).



FIGURE 12 — CRTC HORIZONTAL TIMING

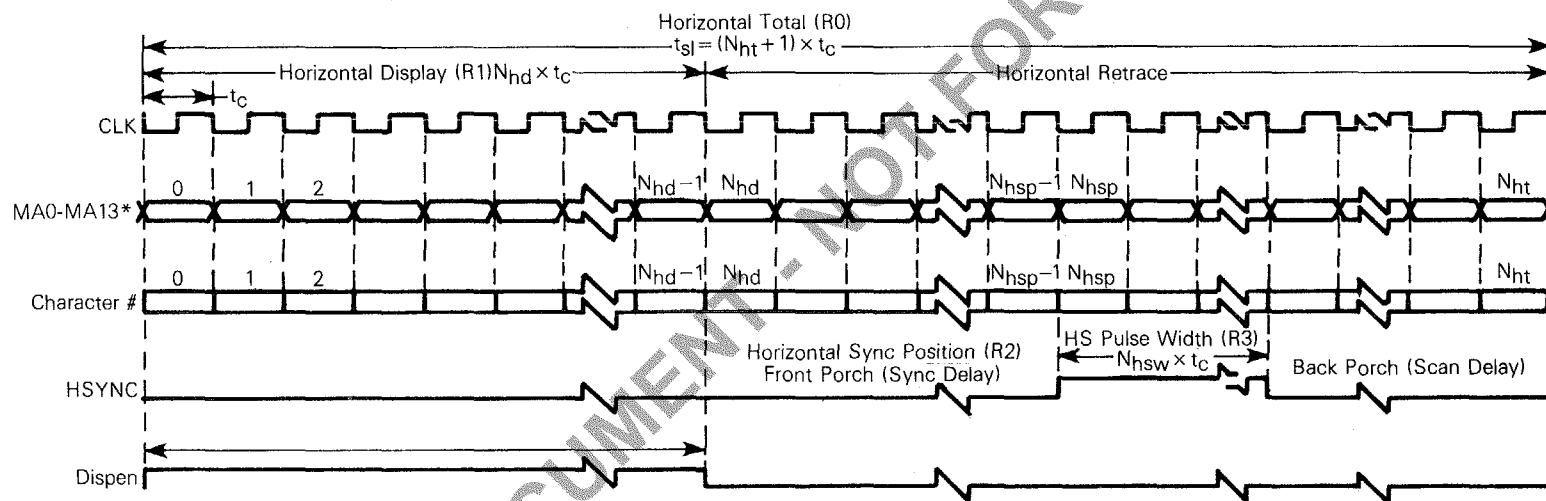

\* Timing is shown for first displayed scan row only. See chart in Figure 15 for other rows. The initial MA is determined by the contents of start address register, R12/R13. Timing is shown for R12/R13=0.

NOTE: Timing values are described in Table 5.



ARCHIVE DOCUMENT - NOT FOR NEW DESIGN

FIGURE 13 — CRTC VERTICAL TIMING

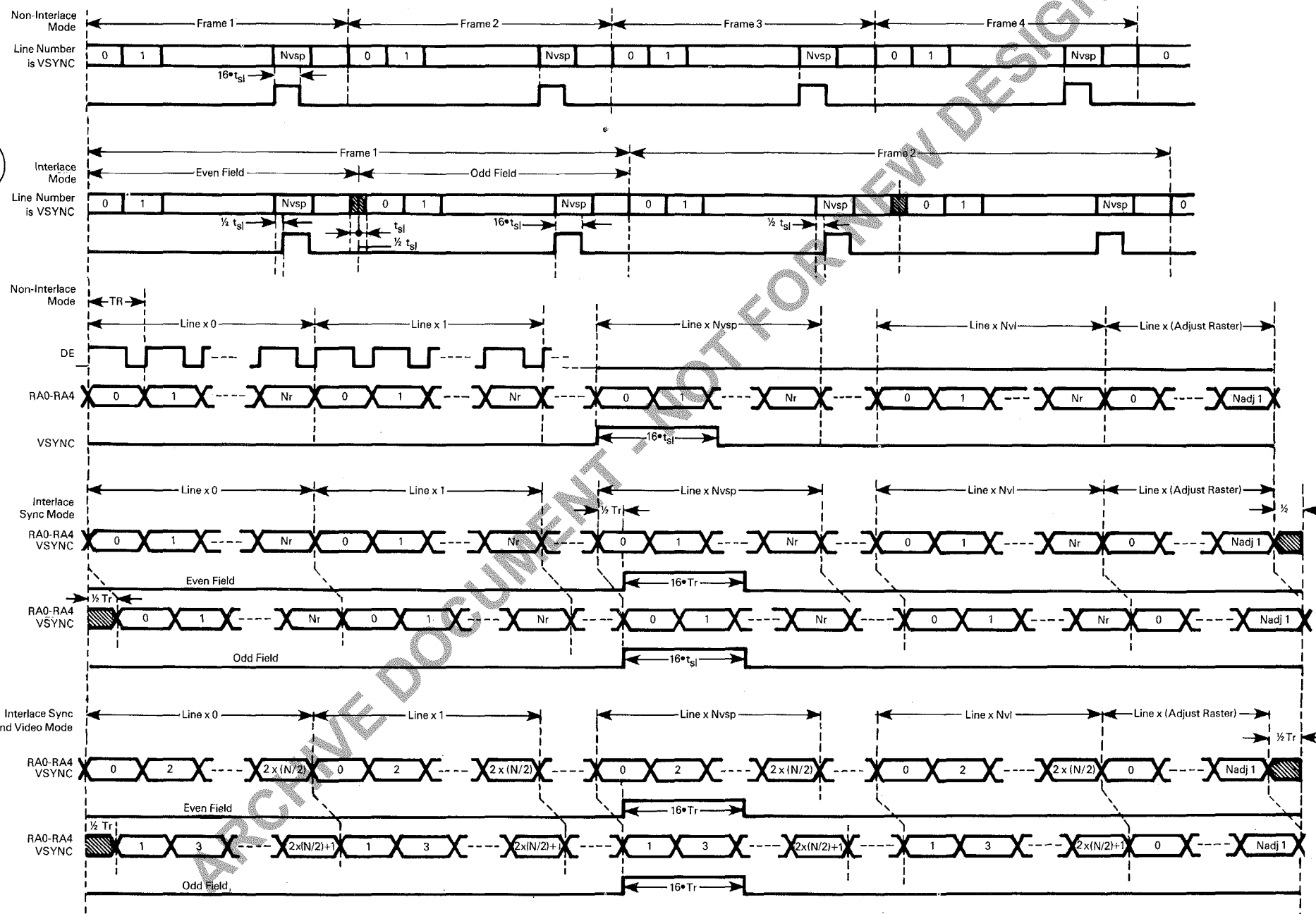

NOTES: 1. In interlace sync and video mode, maximum raster address (Nr) shall be odd.  
 2. In interlace mode, Nht shall be odd.



FIGURE 14 — INTERLACE CONTROL

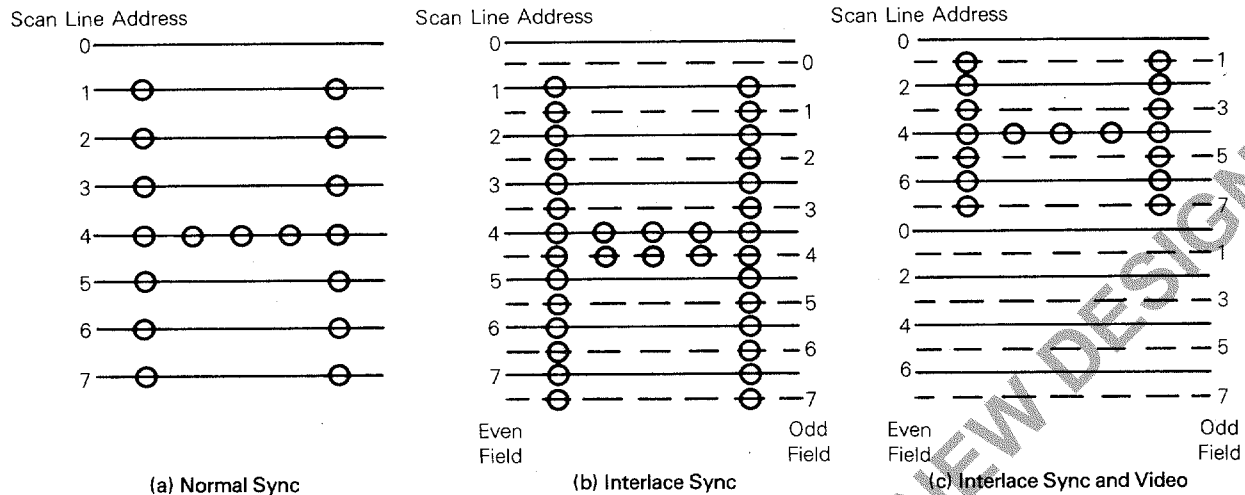

**Maximum Scan Line Address Register (R9)** — This 5-bit write-only register determines the number of scan lines per character row including the spacing; thus, controlling operation of the row address counter. The programmed value is a maximum address and is one less than the number of scan lines.

**CURSOR CONTROL**

**Cursor Start Register (R10) and Cursor End Register (R11)** — These registers allow a cursor of up to 32 scan lines in height to be placed on any scan line of the character block as shown in Figure 15. R10 is a 7-bit write-only register used to define the start scan line and the cursor blink rate. Bits 5 and 6 of the cursor start address register control the cursor operation as shown in Table 4. Non-display, display, and two blink modes (16 times or 32 times the field period) are available. R11 is a 5-bit write-only register which defines the last scan line of the cursor.

TABLE 4 — CURSOR START REGISTER

Bit 6	Bit 5	Cursor Display Mode
0	0	Non-Blink
0	1	Cursor Non-Display
1	0	Blink, 1/16 Field Rate
1	1	Blink, 1/32 Field Rate

Example of cursor display mode

When an external blink feature on characters is required, it may be necessary to perform cursor blink externally so that both blink rates are synchronized. Note that an invert/non-

invert cursor is easily implemented by programming the CRTC for a blinking cursor and externally inverting the video signal with an exclusive-OR gate.

**Cursor Register (R14-H, R15-L)** — This 14-bit read/write register pair is programmed to position the cursor anywhere in the refresh RAM area; thus, allowing hardware paging and scrolling through memory without loss of the original cursor position. It consists of an 8-bit low order (MA0-MA7) register and a 6-bit high order (MA8-MA13) register.

**OTHER REGISTERS**

**Start Address Register (R12-H, R13-L)** — This 14-bit write-only register pair controls the first address output by the CRTC after vertical blanking. It consists of an 8-bit low order (MA0-MA7) register and a 6-bit high order (MA8-MA13) register. The start address register determines which portion of the refresh RAM is displayed on the CRT screen. Hardware scrolling by character or page may be accomplished by modifying the contents of this register.

**Light Pen Register (R16-H, R17-L)** — This 14-bit read-only register pair captures the refresh address output by the CRTC on the positive edge of a pulse input to the LPSTB pin. It consists of an 8-bit low order (MA0-MA7) register and a 6-bit high order (MA8-MA13) register. Since the light pen pulse is asynchronous with respect to refresh address timing an internal synchronizer is designed into the CRTC. Due to delays (Figure 5) in this circuit, the value of R16 and R17 will need to be corrected in software. Figure 16 shows an interrupt driven approach although a polling routine could be used.



FIGURE 15 — CURSOR CONTROL

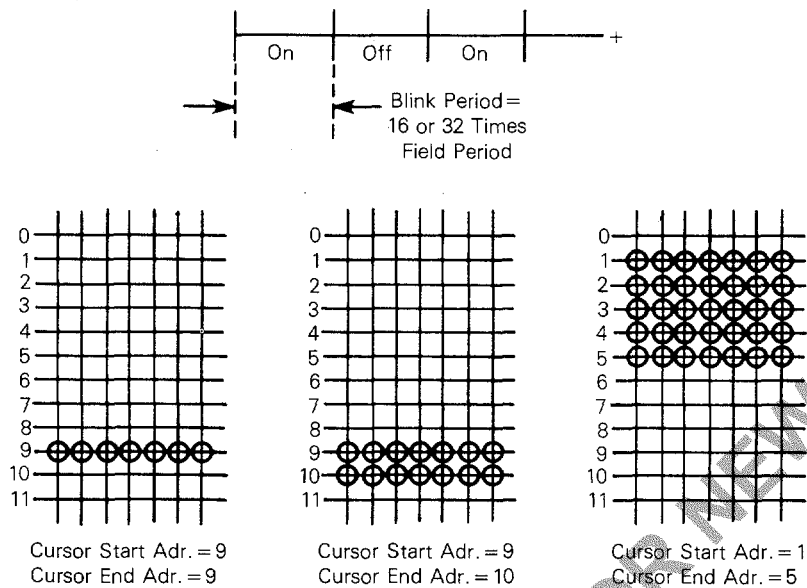
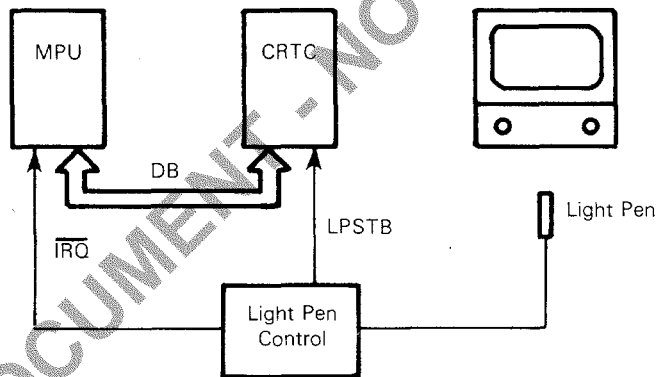

FIGURE 16 — INTERFACING OF LIGHT PEN



OPERATION OF THE CRTC

TIMING CHART OF THE CRT INTERFACE SIGNALS

Timing charts of CRT interface signals are illustrated in this section. When values listed in Table 5 are programmed into CRTC control registers, the device provides the outputs as shown in the timing diagrams (Figures 12, 13, 17, and 18). The screen format is shown in Figure 11 which illustrates the relation between refresh memory address (MA0-MA13), raster address (RA0-RA4), and the position on the screen. In this example, the start address is assumed to be zero.

TABLE 5 — VALUES PROGRAMMED INTO CRTC REGISTERS

Reg. #	Register Name	Value	Programmed Value
R0	H. Total	$N_{ht} + 1$	$N_{ht}$
R1	H. Displayed	$N_{hd}$	$N_{hd}$
R2	H. Sync Position	$N_{hsp}$	$N_{hsp}$
R3	H. Sync Width	$N_{hsw}$	$N_{hsw}$
R4	V. Total	$N_{vt} + 1$	$N_{vt}$
R5	V. Scan Line Adjust	$N_{adj}$	$N_{adj}$
R6	V. Displayed	$N_{vd}$	$N_{vd}$
R7	V. Sync Position	$N_{vsp}$	$N_{vsp}$
R8	Interlace Mode		
R9	Max. Scan Line Address	$N_{sl}$	$N_{sl}$





FIGURE 17 – CURSOR TIMING

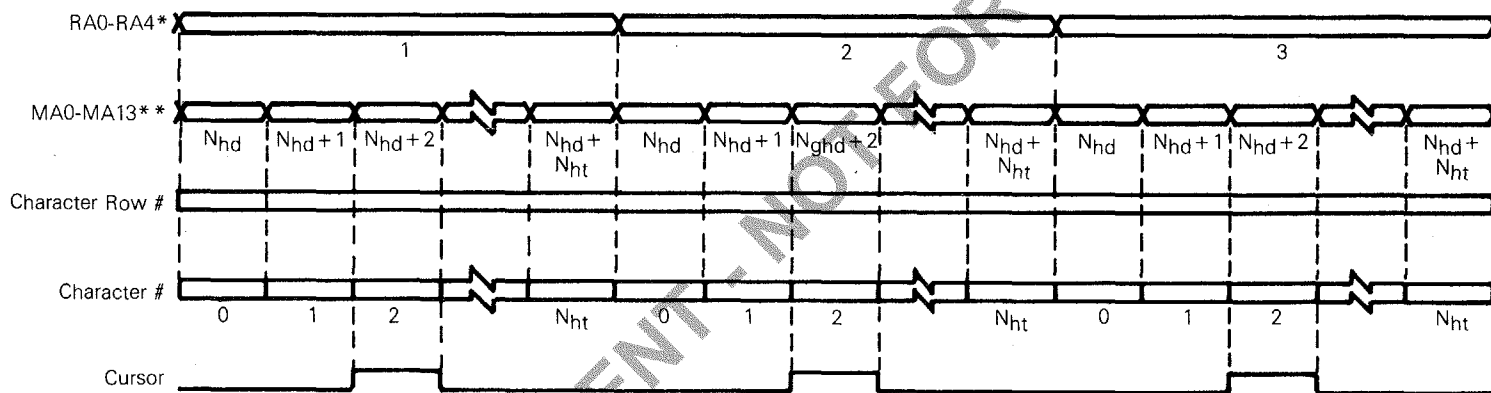

\* Timing is shown for non-interlace and interlace sync modes.

Example shown has cursor programmed as:

Cursor Register =  $N_{hd}+2$

Cursor Start = 1

Cursor End = 3

\*\* The initial MA is determined by the contents of start address register, R12/R13. Timing is shown for R12/R13=0.

NOTE 1: Timing values are described in Table 5.

ARCHIVE DOCUMENT - NOT FOR NEW DESIGN

FIGURE 18 — REFRESH MEMORY ADDRESSING (MA0-MA13) STAGE CHART

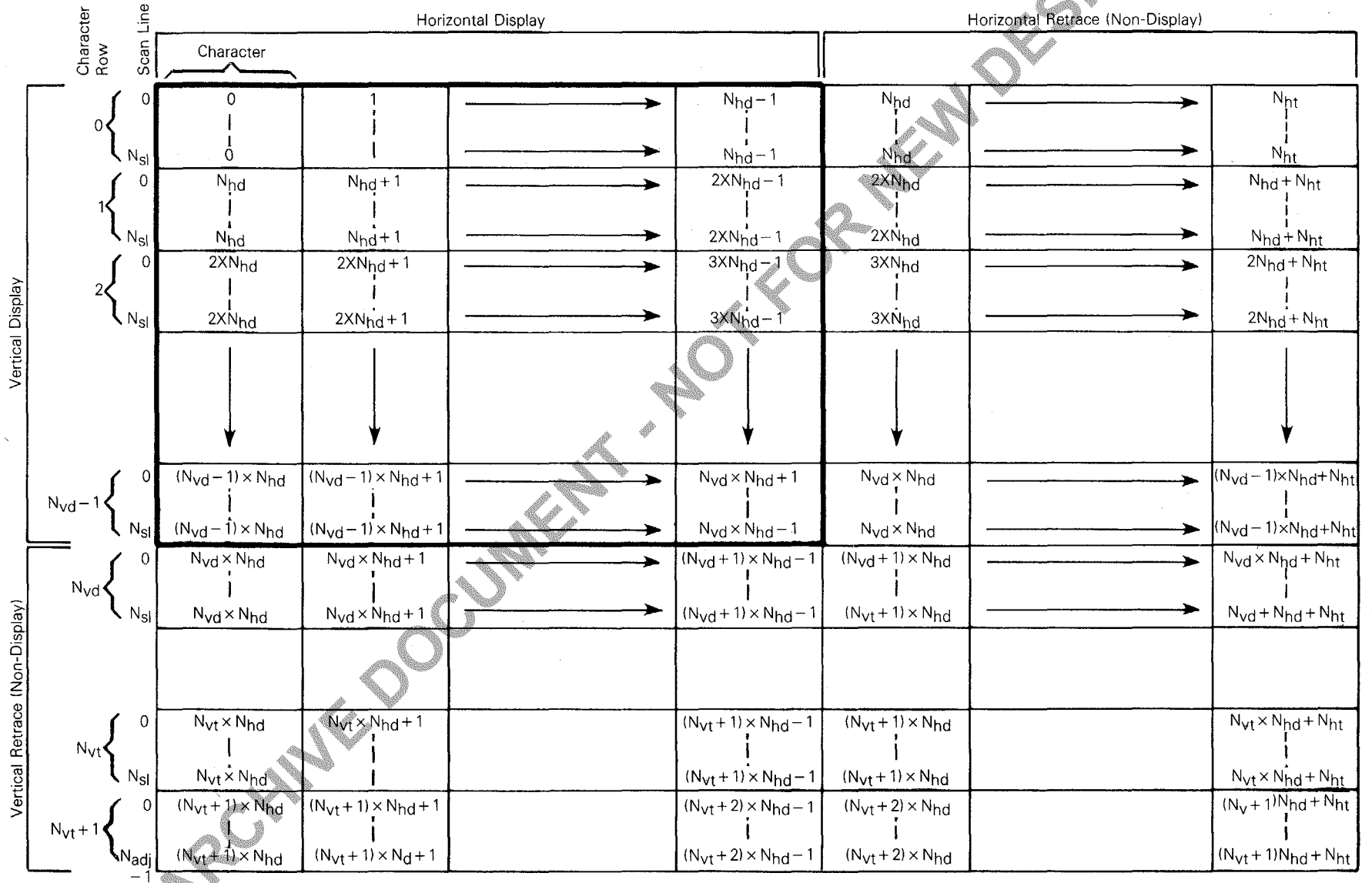

NOTE 1: The initial MA is determined by the contents of start address register, R12/R13. Timing is shown for R12/R13=0. Only non-interlace and interlace sync modes are shown.



### DETERMINING REGISTER CONTENTS

Some of the register contents are determined rather easily. They are:

Register	Name	Contents
R8	Interlace Mode Register	See Table 3
R10	Cursor Start	See Figure 15 and Table 4
R11	Cursor End	See Figure 15
R12	Start Address (H)	User programs first
R13	Start Address (L)	memory location to be displayed
R14	Cursor (H)	User programs desired
R15	Cursor (L)	cursor location
R16	Light Pen (H)	Can be loaded via
R17	Light Pen (L)	light-pen strobe only

The remaining register contents must be determined from some basic data related to the CRT monitor and from the user-desired display format. The CRT reference sheet (see Figure 19) gives a set of formulas for calculating the register contents as well as other useful characteristics of the display. This type of data is summarized under basic parameters in Figures 20 and 21; most or all of this data must be supplied by the user before he can determine the contents for registers R0-R7 and R9. All variables B<sub>1</sub>-B<sub>10</sub> are equal to basic parameters 1 through 10.

FIGURE 19 — CRT REFERENCE SHEET

Register Function		Intermediate Calculations			Register Calculations	
		Symbol	Description	Calculation	Register	Calculation
R0	Horizontal Total					
R1	Horizontal Displayed	f	Dot frequency (1st approx.)	$\frac{B_5 \cdot (B_7 + B_9)}{(1/B_1) - B_3}$	R0	$\frac{f}{B_1 \cdot (B_7 + B_9)} - 1$
R2	Horizontal Sync Position					
R3	Horizontal Sync Width	t <sub>c</sub>	Character Time	$\frac{1}{[(R0) + 1] \cdot B_1}$	R1	B <sub>5</sub>
R4	Vertical Total	f	Dot frequency	$\frac{B_7 + B_9}{t_c}$		
R5	Vertical Total Adjust				R2	$(R1) + \frac{(R3)}{2}$
R6	Vertical Displayed	t <sub>sl</sub>	Scan line time	$[(R0) + 1] \cdot t_c$	R3	$\frac{(R0) - (R1)}{3}$
R7	Vertical Sync Position	n	Total # of scan lines	$\frac{1}{B_2 \cdot t_{sl}}$		
R8	Interlace Mode				R4	N - 1
R9	Maximum Scan Line Address	N	Integer and	$\frac{n}{B_8 + B_{10}} = N + \frac{R}{B_8 + B_{10}}$	R5	R
R10	Cursor Start	R	Integer remainder			
R11	Cursor End				R6	B <sub>6</sub>
R12	Start Address (H)	t <sub>cr</sub>	Character row time	$(B_8 + B_{10}) \cdot t_{sl}$	R7	$[(R4) + 1] - \frac{16 - (R5) \geq (R7) \geq (R6)}{B_8 + B_{10}}$
R13	Start Address (L)	t <sub>hr</sub>	Horizontal retrace time	$\leq \frac{[(R0) + 1 - B_5] \cdot (B_7 + B_9)}{f}$		
R14	Cursor (H)				R9	$(B_8 + B_{10}) - 1$
R15	Cursor (L)	t <sub>vr</sub>	Vertical retrace time	$\leq \frac{B_1}{B_2} - B_6(B_8 + B_{10}) \cdot t_{sl}$		
R16	Light Pen (H)					
R17	Light Pen (L)					



In Figures 20 and 21, worksheet example calculations are shown for 32x16 and 80x24 display formats respectively. The following items are keyed to the figures. Basic parameters ① through ⑩ have been provided; items ① through ④ are data about the CRT monitor and items ⑤ through ⑩ are data about the user's desired display.

- ① Calculate the approximate dot frequency. The user should verify that the bandwidth of his CRT monitor will accommodate this frequency.
- ② Calculate R0. The resultant answer will usually be an integer plus a fraction. Assume the next high integer.
- ③ Fill in value for R1.
- ④ Calculate R3. Use the next highest integer. In these examples the sync width was chosen to be one third of the horizontal blanking interval.
- ⑤ Calculate R2. Again, use the next highest integer.
- ⑥ Calculate t<sub>c</sub>, character tie. This is the time required for one scan line of one character block to be written.
- ⑦ Calculate the exact dot frequency.
- ⑧ Calculate t<sub>sl</sub>, scan line time. This is the time required for one scan line of one character row to be written including retrace time.

- ⑨ Calculate n. This is the total number of scan lines for each frame. Discard any fraction.
- ⑩ Calculate N and R.
- ⑪ Calculate R4.
- ⑫ Fill in R5.
- ⑬ Fill in R6.
- ⑭ Calculate R7. If there is no possible value for R7, then the display demands for the CRT monitor exceed its capability. A compromise adjustment must be made in basic parameter 6, 8, or 10.
- ⑮ Calculate R9.
- ⑯ Calculate t<sub>cr</sub>. This is the time required for one character row to be written.
- ⑰ Calculate t<sub>hr</sub>. t<sub>hr</sub> > B3.
- ⑱ Calculate t<sub>vr</sub>. t<sub>vr</sub> > B4.

In Figure 20, calculation ⑮ verifies that the vertical period is 16.667 milliseconds or 60 hertz. The expression used is:

$$t_{cr} \times [(R4) + 1] + [t_{sl} \times (R5)] = Vp.$$

Another check is calculation of horizontal sync pulse width R3. t<sub>c</sub> = PW<sub>HS</sub> (typically approximately equals 4 microseconds).

For convenience, a blank worksheet is provided in Figure 22.

FIGURE 20 — CRT WORKSHEET EXAMPLE CALCULATION (32x16)

Basic Parameters (B1-B10)	Symbol	Intermediate Calculations	Register Calculations				
			Value	Register	Decimal	Hex	
1. Horizontal frequency = 15750 ± 500 ①	f'	$\frac{32 \times (5+2)}{1 - 11 \times 10^{-6}}$ 15750	= 4.27 × 10 <sup>6</sup>	② R0	$\frac{4.27 \times 10^6}{15,750 \times (5+2) - 1}$	38	26
2. Vertical frequency = 60 ⑥	t <sub>c</sub>	$\frac{1}{39 \times 15750}$	= 1.63 × 10 <sup>-6</sup>	③ R1	B <sub>5</sub> = 32	32	20
3. Minimum Horizontal retrace time = 11 × 10 <sup>-6</sup> ⑦	f	$\frac{5+2}{1.63 \times 10^{-6}}$	= 4.29 × 10 <sup>6</sup>	⑤ R2	32 + $\frac{3}{2}$	33	21
4. Minimum vertical retrace time = 10 <sup>-3</sup> ⑧	t <sub>sl</sub>	39 × 1.63 × 10 <sup>-6</sup>	= 63.6 × 10 <sup>-6</sup>	④ R3	$\frac{38-32}{3}$	2	2
5. # of displayed characters per row = 32 ⑨	n	$\frac{1}{60 \times 63.6 \times 10^{-6}}$	= 262	⑪ R4	17 - 1 =	16	10
6. # of displayed character rows = 16 ⑩	N		17	⑫ R5	R = 7	7	7
7. # of dots in character dot matrix row = 5 R	R	$\frac{262}{7+8}$	= 7	⑬ R6	B <sub>6</sub> = 16	16	10
8. # of scan lines in character matrix column = 7 ⑬	t <sub>cr</sub>	(7+8) × 63.6 × 10 <sup>-6</sup>	= 954 × 10 <sup>-6</sup>	⑭ R7	(A)	16	10
9. Number of dots between horizontal adjacents = 2 ⑰	t <sub>hr</sub>	$\frac{(38+1-32) \cdot (5+2)}{4.29 \times 10^6}$	= 11.42 × 10 <sup>-6</sup>	R8			
10. Number of scan lines between vertical adjacents = 8 ⑱	t <sub>vr</sub>	$\frac{[15750 - 16(7+8)] \times 63.6 \times 10^{-6}}{60}$	= 1.431 × 10 <sup>-3</sup>	⑮ R9	7+8-1 =	14	0E
① 16+1 - $\frac{16-7}{7+8} \geq (R7) \geq 16$				R10			
② 17 - .6 ≥ (R7) ≥ 16				R11			
				R12			
				R13			
				R14			
				R15			
		⑮ 954 × 10 <sup>-6</sup> × 17 = 16.218 × 10 <sup>-3</sup> + 63.6 × 10 <sup>-6</sup> × 7 = .445 × 10 <sup>-3</sup> $\frac{16.663 \text{ ms}}{16.663 \text{ ms}} = \frac{1}{f}$					
		f ≈ 60 Hz					



FIGURE 21 — CRTC WORKSHEET EXAMPLE CALCULATION (80 × 24)

Basic Parameters (B1-B10)		Intermediate Calculations		Register Calculations		
	Symbol		Value	Register	Decimal	Hex
1. Horizontal frequency	= <u>18,600</u> (1) $f'$	$\frac{80 \cdot (7+2)}{18600} - 11 \times 10^{-6}$	$16 \cdot 836 \times 10^6$	(2) R0	$\frac{16.836 \times 10^6 - 1}{(18,600)(9)}$	100 64
2. Vertical frequency	= <u>60</u> (6) $t_c$	$\frac{1}{(100+1) \cdot 18600}$	$532.31 \times 10^{-9}$	(3) R1	B5 = 80	80 50
3. Minimum Horizontal retrace time	= $11 \times 10^{-6}$ (7) $f$	$\frac{7+2}{532.31 \times 10^{-9}}$	$16.907 \times 10^6$	(5) R2	$80 + \frac{7}{2}$	84 54
4. Minimum vertical retrace time	= $1 \times 10^{-3}$ (8) $t_{sl}$	$(100+1)(532.31 \times 10^{-9})$	$53.76 \times 10^{-6}$	(4) R3	$\frac{R0 - R1}{3}$	7 07
5. # of displayed characters per row	= <u>80</u> (9) $n$	$\frac{1}{(60)(53.76 \times 10^{-6})}$	310	(11) R4	28 - 1	27 1B
6. # of displayed character rows	= <u>24</u> (10) $N$		28	(12) R5	R = 2	02 02
7. # of dots in character dot matrix row	= <u>7</u> R	$\frac{310}{11}$	2	(13) R6	B6 = 24	24 18
8. # of scan lines in character • matrix column	= <u>9</u> (16) $t_{cr}$	$(9+2)(53.76 \times 10^{-6})$	$591.39 \times 10^{-6}$	(14) R7	(A)	25 19
9. Number of dots between horizontal adjacents	= <u>2</u> (17) $t_{hr}$	$\leq \frac{(101-80)(7+2)}{16.907 \times 10^6}$	$11.17 \times 10^{-6}$	R8		0 0
10. Number of scan lines between vertical adjacents	= <u>2</u> (18) $t_{vr} \leq \left[ \frac{18600}{60} - 24(11) \right] 53.76 \times 10^{-6}$		$2.47 \times 10^{-3}$	(15) R9	$(9+2) - 1$	10 0A
(A) $(27+1) - \frac{(16-2)}{11} \geq R7 \geq 24$				R10		00 00
26.72 $\geq R7 \geq 24$				R11		11 0B
(B) $B2 = 1/[(t_{cp})(R4+1) + (t_{sp})(R5)]$				R12		00
$= 1/[(591.39 \times 10^6)(28) + (53.76 \times 10^{-6})(2)]$				R13		128 80
$= 1/16.667 \times 10^{-3}$				R14		128 00
$= 60$				R15		80

ARCHIVE DOCUMENT - NOT FOR NEW DESIGN



FIGURE 22 — CRTC WORKSHEET

Basic Parameters	Symbol	Intermediate Calculations		Register Calculations	
		Value	Register	Decimal	Hex
1. Horizontal frequency = _____	$f'$	_____	R0	_____	_____
2. Vertical frequency = _____	$t_c$	_____	R1	_____	_____
3. Minimum Horizontal retrace time = _____	$f$	_____	R2	_____	_____
4. Minimum vertical retrace time = _____	$t_{sl}$	_____	R3	_____	_____
5. # of displayed characters per row = _____	$n$	_____	R4	_____	_____
6. # of displayed character rows = _____	$N$	_____	R5	_____	_____
7. # of dots in character dot matrix row = _____	$R$	_____	R6	_____	_____
8. # of scan lines in character • matrix column = _____	$t_{cr}$	_____	R7	_____	_____
9. Number of dots between horizontal adjacents = _____	$t_{hr}$	_____	R8	_____	_____
10. Number of scan lines between vertical adjacents = _____	$t_{vr}$	_____	R9	_____	_____
			R10	_____	_____
			R11	_____	_____
			R12	_____	_____
			R13	_____	_____
			R14	_____	_____
			R15	_____	_____
			R16	_____	_____
			R17	_____	_____
			R18	_____	_____
			R19	_____	_____

**CRTC INITIALIZATION**

Register R0-R15 must be initialized after the system is powered up. The processor will normally load the CRTC register file from a firmware table. The program required to initialize the CRTC for a 80x24 format (example calculation #2) is shown in Figure 23.

The CRTC registers will have an initial value at power up. When using a direct drive monitor (sans horizontal oscillator) these initial values may result in out-of-tolerance operation. CRTC programming should be done immediately after power up especially in this type of system.

**ADDITIONAL CRTC APPLICATIONS**

The foremost system function which may be performed by the CRTC controller is the refreshing of dynamic RAM. This

is quite simple as the refresh addresses continually run.

Note that the LPSTB input may be used to support additional system functions other than a light pen. A digital-to-analog converter (DAC) and comparator could be configured to use the refresh addresses as a reference to a DAC composed of a resistive adder network connected to a comparator. The output of the comparator would generate the LPSTB input signifying a match between the refresh address analog level and the unknown voltage.

The light-pen strobe input could also be used as a character strobe to allow the CRTC refresh addresses to decode a keyboard matrix. Debouncing would need to be done in software.

Both the VS and HS outputs may be used as a real-time clock. Once programmed, the CRTC will provide a stable reference frequency.



FIGURE 23 — MC6800 PROGRAM FOR CRTC INITIALIZATION

PAGE 001 CRTCINIT.SA:0 MC6845 CRTC Initialization Program

```

00001          NAM      MC6845
00002          TTL      / MC6845-1 CRTC initialization program
00003          OPT      G,S,LLE=85 print FCB's, FDB's & XREF table
00004          *****
00005          * Assign CRTC addresses
00006          *
00007          9000  A CRTCAD EQU      $9000      Address Register
00008          9001  A CRTCRG EQU     CRTCAD+1    Data Register
00009          *****
00010          * Initialization program
00011          *
00012A 0000          ORG      0          a place to start
00013A 0000 5F          CLRB          clear counter
00014A 0001 CB 1020  A          LDX      #CRTTAB  table pointer
00015A 0004 F7 9000  A CRTC1 STAB     CRTCAD    load address register
00016A 0007 A6 00   A          LDAA     0,X      get register value from table
00017A 0009 B7 9001  A          STAA     CRTCRG   program register
00018A 000C 08          INX          increment counters
00019A 000D 5C          INCB
00020A 000E C1 10   A          CMPB     $10    finished?
00021A 0010 26 F2 0004      BNE     CRTC1  no: take branch
00022A 0012 3F          SWI          yes: call monitor
00023          *****
00024          * CRTC register initialization table
00025          * 80 x 24 non-interlaced format
00026A 1020          ORG      $1020    start of table
00027A 1020 65  A CRTTAB FCB     $64,$50    R0, R1 - H total & H displayed
          A 1021 50  A
00028A 1022 56  A          FCB     $54,$07    R2, R3 - HS pos. & HS width
          A 1023 09  A
00029A 1024 18  A          FCB     $1B,$02    R4, R5 - V total & V total adj.
          A 1025 0A  A
00030A 1026 18  A          FCB     $18,$19    R6, R7 - V displayed $ VS pos.
          A 1027 18  A
00031A 1028 00  A          FCB     $00,$0A    R8, R9 - Interlace & Max scan line
          A 1029 0B  A
00032A 102A 00  A          FCB     $00,$0B    R10,R11- Cursor start & end
          A 102B 0B  A
00033A 102C 0080 A          FDB     $0080    R12,R13- Start Address
00034A 102E 0080 A          FDB     $0080    R14,R15- Cursor Address
00035          END
TOTAL ERRORS 00000--00000

CRTC1  0004  CRTCAD 9000  CRTCRG 9001  CRTTAB 1020

```

Motorola reserves the right to make changes to any products herein to improve reliability, function or design. Motorola does not assume any liability arising out of the application or use of any product or circuit described herein; neither does it convey any license under its patent rights nor the rights of others.



PACKAGE DIMENSIONS

**L SUFFIX**  
CERAMIC PACKAGE  
CASE 715-05

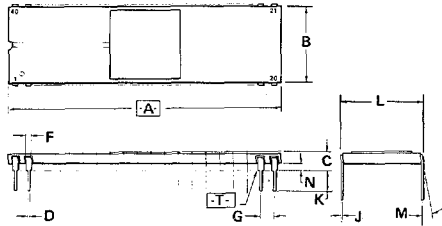

- NOTES:
1. DIMENSION  $\square$ A $\square$  IS DATUM.
  2. POSITIONAL TOLERANCE FOR LEADS:  
 $\oplus 0.25 (0.010) \text{ T A } \textcircled{\ominus}$
  3.  $\square$ T $\square$  IS SEATING PLANE.
  4. DIMENSION "L" TO CENTER OF LEADS WHEN FORMED PARALLEL.
  5. DIMENSIONING AND TOLERANCING PER ANSI Y14.5, 1973.

DIM	MILLIMETERS		INCHES	
	MIN	MAX	MIN	MAX
A	50.29	51.31	1.980	2.020
B	14.63	15.49	0.576	0.610
C	2.79	4.32	0.110	0.170
D	0.38	0.53	0.015	0.021
F	0.76	1.52	0.030	0.060
G	2.54 BSC		0.100 BSC	
J	0.20	0.33	0.008	0.013
K	2.54	4.87	0.100	0.180
L	14.99	15.65	0.590	0.616
M		10°		15°
N	1.02	1.52	0.040	0.060

**S SUFFIX**  
CERDIP PACKAGE  
CASE 734-04

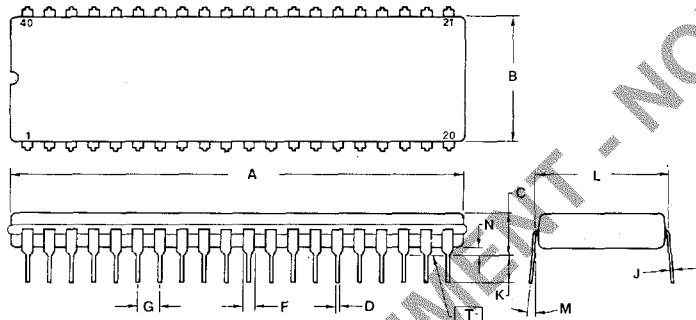

- NOTES:
1. DIM -A- IS DATUM.
  2. POSITIONAL TOLERANCE FOR LEADS:  
 $\oplus 0.25 (0.010) \text{ T A } \textcircled{\ominus}$
  3.  $\square$ T $\square$  IS SEATING PLANE.
  4. DIM L TO CENTER OF LEADS WHEN FORMED PARALLEL.
  5. DIMENSIONS A AND B INCLUDE MENISCUS.
  6. DIMENSIONING AND TOLERANCING PER ANSI Y14.5, 1973.

DIM	MILLIMETERS		INCHES	
	MIN	MAX	MIN	MAX
A	51.31	53.24	2.020	2.096
B	12.70	15.49	0.500	0.610
C	4.06	5.84	0.160	0.230
D	0.38	0.56	0.015	0.022
F	1.27	1.65	0.050	0.065
G	2.54 BSC		0.100 BSC	
J	0.20	0.30	0.008	0.012
K	3.18	4.06	0.125	0.160
L	15.24 BSC		0.600 BSC	
M		5°		15°
N	0.51	1.27	0.020	0.050

**P SUFFIX**  
PLASTIC PACKAGE  
CASE 711-03

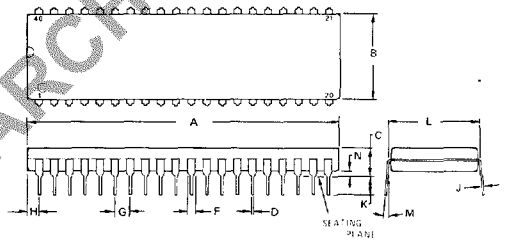

- NOTES:
1. POSITIONAL TOLERANCE OF LEADS (D), SHALL BE WITHIN 0.25 mm (0.010) AT MAXIMUM MATERIAL CONDITION, IN RELATION TO SEATING PLANE AND EACH OTHER.
  2. DIMENSION L TO CENTER OF LEADS WHEN FORMED PARALLEL.
  3. DIMENSION B DOES NOT INCLUDE MOLD FLASH.

DIM	MILLIMETERS		INCHES	
	MIN	MAX	MIN	MAX
A	51.69	52.45	2.035	2.065
B	13.72	14.22	0.540	0.560
C	3.94	5.08	0.155	0.200
D	0.36	0.56	0.014	0.022
F	1.02	1.52	0.040	0.060
G	2.54 BSC		0.100 BSC	
H	1.65	2.16	0.065	0.085
J	0.20	0.38	0.008	0.015
K	2.92	3.43	0.115	0.135
L	15.24 BSC		0.600 BSC	
M		0°		15°
N	0.51	1.02	0.020	0.040



**MOTOROLA Semiconductor Products Inc.**

3501 ED BLUESTEIN BLVD., AUSTIN, TEXAS 78721 • A SUBSIDIARY OF MOTOROLA INC.