

FEATURES

- two output pairs, adjustable from 0 to 1100 mVp-p into 75 Ω loads
- nominal 600 ps rise and fall times
- accepts SMPTE and standard ECL input levels
- operates from a single +5 or -5 volt supply
- on-chip DC restoration for low jitter
- 250 mW power dissipation
- interfaces with **GENLINX™ GS9002, GS9004A, GS9005A and GS9015A**

APPLICATIONS

- SMPTE 259M Serial Digital Systems (4:2:2 & 4fsc)
- Other Serial Digital Video Interfaces - 360 Mb/s
- General purpose high speed driver applications

PIN CONNECTIONS

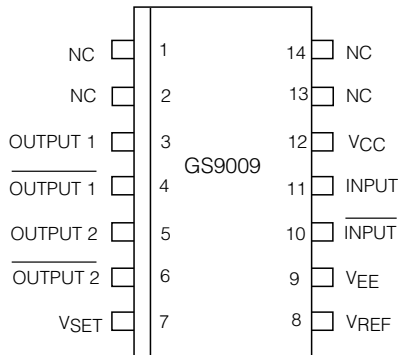

ORDERING INFORMATION

Part Number	Package Type	Temperature Range
GS9009 - CKB	14 Pin SOIC	0° to 70°C

DEVICE DESCRIPTION

The **GENLINX™** GS9009 is a bipolar integrated circuit designed to drive four 75 Ω co-axial cables at data rates exceeding 400 Mb/s. It directly interfaces with other **GENLINX™** devices and can also be used as a general purpose high speed cable driver.

The differential inputs are AC-coupled and internally DC-restored which allows correct passage of pathological check codes associated with the serial digital standards. Even though the inputs are AC coupled, static protection diodes at each input restrict the DC differential so that if the driving source uses the opposite polarity power supply, external DC blocking capacitors must be used.

Correctly terminated output signal levels are adjustable from as low as 0 mV to as high as 1100 mV with little change in other performance parameters. Performance is guaranteed for output levels between 600 mV and 1000 mV. The gain of the output stages is varied by adjusting the V_{SET} voltage with respect to an internal bandgap reference voltage V_{REF} .

Pinout is compatible with the GS9007 by interchanging pins 3,4,5,6,9,10,11,12 on the GS9009 with pins 1,2,3,4,5,6,7,8 on the GS9007. In this way, a layout can be made for either device depending on whether adjustability is desired or not.

The GS9009 is packaged in a 14 pin SOIC, and operates from a single +5 or -5 volt supply consuming typically only 250 mW of power.

FUNCTIONAL BLOCK DIAGRAM

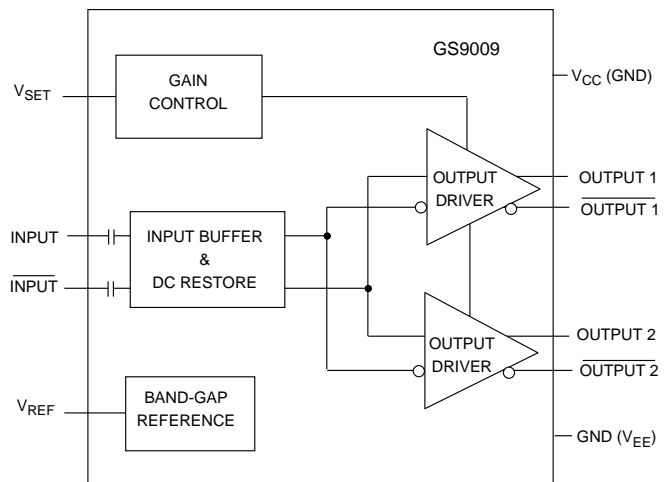

Patent No. 5,426,389.

ABSOLUTE MAXIMUM RATINGS

PARAMETER	VALUE
Supply Voltage (V_S)	5.5 V
Input Voltage Range (any input)	$V_S - 0.5$ V
Power Dissipation	300 mW
Operating Temperature Range	$0^\circ\text{C} \leq T_A \leq 70^\circ\text{C}$
Storage Temperature Range	$-65^\circ\text{C} \leq T_S \leq 150^\circ\text{C}$
Lead Temperature (soldering, 10 sec)	260°C

GS9009 CABLE DRIVER - DC ELECTRICAL CHARACTERISTICS

Conditions: $V_S = 5\text{V}$, $T_A = 0^\circ\text{C}$ to 70°C , $R_L = 150\ \Omega$ to GND and $144\ \Omega$ AC coupled unless otherwise shown

PARAMETER	SYMBOL	CONDITIONS	MIN	TYP	MAX	UNITS	NOTES
Supply Voltage	V_S		4.5	5.0	5.5	volts	
Power Consumption	P_D	4 x 150 Ω Loads DC	-	250	290	mW	
Supply Current	I_{S1}	1% Accuracy, $T_A = 25^\circ\text{C}$ $V_{SET} = (0.667) V_{REF}$	-	105	110	mA	
Supply Current	I_{S2}	DC No Loads, $T_A = 25^\circ\text{C}$	-	16	20	mA	
Reference Voltage	V_{REF}	10 k Ω to ground	-	1.2	-	volts	

GS9009 CABLE DRIVER - AC ELECTRICAL CHARACTERISTICS

Conditions: $V_S = 5\text{V}$, $T_A = 0^\circ\text{C}$ to 70°C , $R_L = 150\ \Omega$ to GND and $144\ \Omega$ AC coupled unless otherwise shown

PARAMETER	SYMBOL	CONDITIONS	MIN	TYP	MAX	UNITS	NOTES
Input Signal Amplitude	V_{IN}		700	800	1000	mVp-p	
Input Signal Rise/Fall Times	t_R, t_F		-	-	750	ps	
Output Amplitudes across 75 Ω Load (See Note 1)	V_{OUT}	$V_{SET} = (0.5) V_{REF}$	540	600	660	mVp-p	Note 1 & 2
		$V_{SET} = (0.667) V_{REF}$	720	800	880	mVp-p	Note 1 & 2
		$V_{SET} = (0.833) V_{REF}$	900	1000	1100	mVp-p	Note 1 & 2
Output Amplitude Temperature Coefficient (See Note 2)	T_C	$V_{SET} = (0.5) V_{REF}$	-	25	100	ppm/ $^\circ\text{C}$	
		$V_{SET} = (0.667) V_{REF}$	-	-12	80	ppm/ $^\circ\text{C}$	
		$V_{SET} = (0.833) V_{REF}$	-	-45	80	ppm/ $^\circ\text{C}$	
Output Rise/Fall Times (20% to 80%)	t_R, t_F	$V_{SET} = (0.5) V_{REF}$	400	630	800	ps	
		$V_{SET} = (0.667) V_{REF}$	400	575	800	ps	
		$V_{SET} = (0.833) V_{REF}$	400	530	800	ps	
Output Overshoot		$t_R = t_F = 600$ ps	-	0	-	%	See Figure 3
Jitter	t_J	at 270 Mb/s	-	-	± 25	ps	
Propagation Delay	t_P		-	1	-	ns	

NOTE 1. V_{OUT} is measured across a correctly terminated load, back matched to the device. The peak to peak voltage of the device itself is $2 \times V_{OUT}$.

2. V_{OUT} is proportional to V_{SET} and V_{SET} may be an external low impedance, high stability supply. In this case the amplitude temperature coefficient will not be guaranteed.

INPUT / OUTPUT CIRCUITS

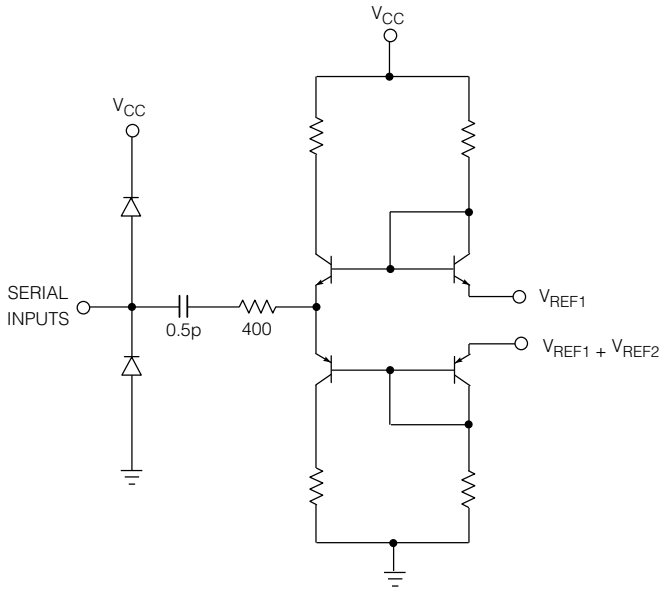

Fig. 1 Input Circuit (Pins 11 and 12)

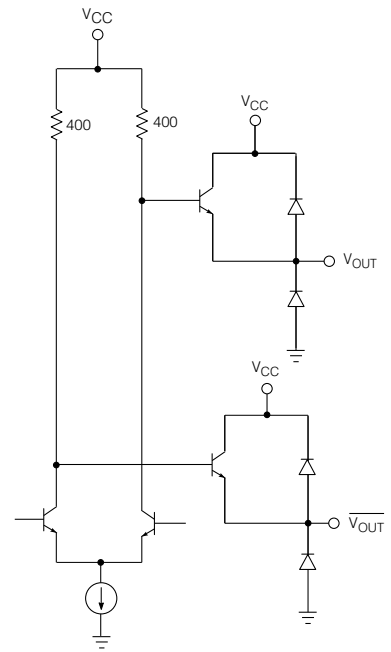

Fig. 2 Output Circuit (Pins 3, 4 and 5, 6)

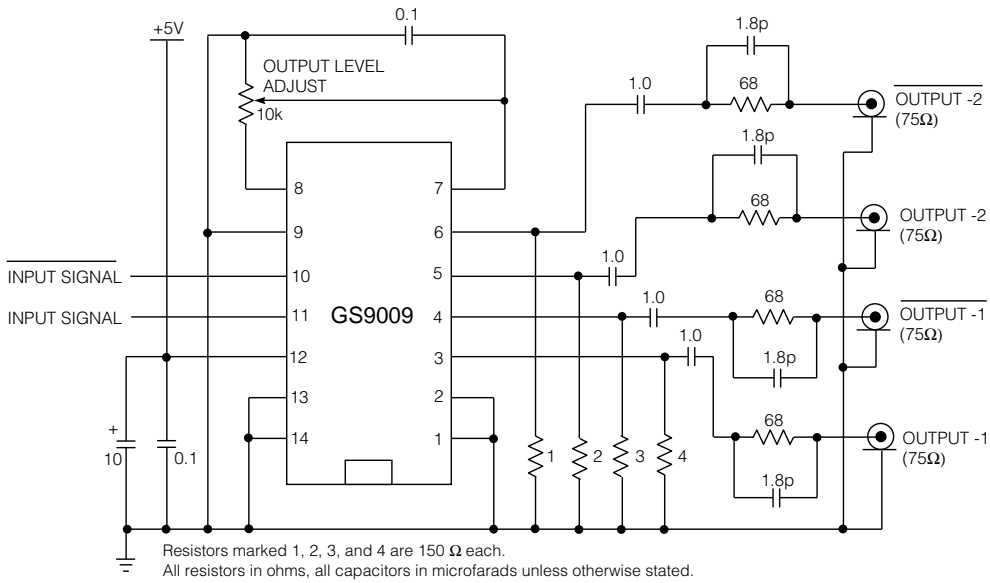
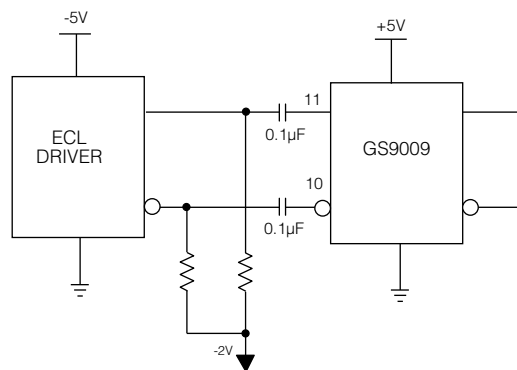

Fig. 3 Typical Application Circuit



All resistors in ohms, all capacitors in microfarads unless otherwise stated.

Fig. 4 Split Supply Interfacing

REVISION NOTES

Updated to Data Sheet, Figure 4 added

CAUTION
ELECTROSTATIC
SENSITIVE DEVICES
DO NOT OPEN PACKAGES OR HANDLE
EXCEPT AT A STATIC-FREE WORKSTATION



DOCUMENT IDENTIFICATION

PRODUCT PROPOSAL

This data has been compiled for market investigation purposes only, and does not constitute an offer for sale.

ADVANCE INFORMATION NOTE

This product is in development phase and specifications are subject to change without notice. Gennum reserves the right to remove the product at any time. Listing the product does not constitute an offer for sale.

PRELIMINARY DATA SHEET

The product is in a preproduction phase and specifications are subject to change without notice.

DATA SHEET

The product is in production. Gennum reserves the right to make changes at any time to improve reliability, function or design, in order to provide the best product possible.

Gennum Corporation assumes no responsibility for the use of any circuits described herein and makes no representations that they are free from patent infringement.

© Copyright January 1993 Gennum Corporation. All rights reserved. Printed in Canada.



LittleDiode supplies new, hard to find or obsolete electronic components and semiconductors all over the world.

With over two million different components listed you are sure to find the part you need.

Feel free to visit us today at our online store:

LittleDiode.com

Looking forward to providing you with the best possible service.