

FEATURES

- automatic cable equalization
- fully compatible with SMPTE 259M
- typically equalizes greater than 350m of high quality cable at 270Mb/s
- signal strength indicator
- output data muting when input data is lost
- output 'eye' monitor (OEM) with large signal amplitude and power down option
- low power: 240mW at 5V
- 14 pin SOIC package
- programmable output data squelch for max cable length limiting
- carrier detect with programmable threshold level
- serial data output "High Z" select to allow muxing of EQ inputs

APPLICATIONS

Front-end cable equalization for digital video systems; Input equalization for serial digital distribution amplifiers, routers, production switchers and other receiving equipment.

DESCRIPTION

The GS9024 is a high performance automatic cable equalizer designed for serial digital data rates from 143Mb/s to 540Mb/s. The GS9024 receives either single-ended or differential serial data and outputs equalized differential signals at PECL levels (800mV). The GS9024 provides up to 40dB of gain at 200MHz which will typically result in equalization of greater than 350m at 270Mb/s of Belden 8281 cable.

The GS9024 incorporates an analog signal strength indicator/carrier detect (SSI/CD) output indicating both the presence of a carrier and the amount of equalization applied to the signal. Optional external resistors allow the carrier detect threshold level to be customized to the user's requirement.

The GS9024 also features selectable High Z serial data outputs eliminating the need for input muxing circuitry in routers. In addition, the GS9024 provides an 'Output Eye Monitor' (OEM) which allows the verification of signal integrity after equalization, prior to reslicing.

The GS9024 operates from a single +5V or -5V power supply and consumes only 240mW of power. Packaged in a small 14 pin SOIC, the GS9024 is ideal for router applications where high density component placement is required.

ORDERING INFORMATION

PART NUMBER	PACKAGE	TEMPERATURE
GS9024-CKB	14 pin SOIC	0°C to 70°C
GS9024-CTB	14 pin SOIC Tape	0°C to 70°C

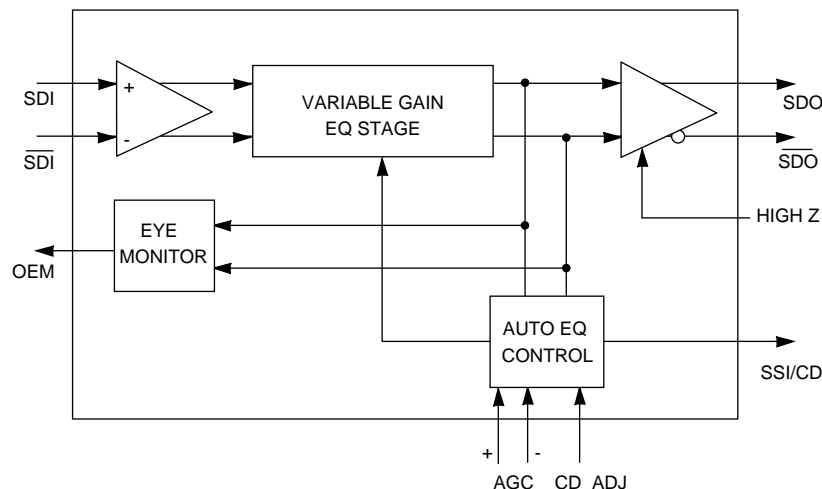

BLOCK DIAGRAM

ABSOLUTE MAXIMUM RATINGS

PARAMETER	VALUE
Supply Voltage	5.5V
Input Voltage Range (any input)	$V_{CC} + 0.5$ to $V_{EE} - 0.5V$
Operating Temperature Range	$0^{\circ}C \leq T_A \leq 70^{\circ}C$
Storage Temperature Range	$-65^{\circ}C \leq T_S \leq 150^{\circ}C$
Lead Temperature (soldering, 10 sec)	260°C

DC ELECTRICAL CHARACTERISTICS

$V_{CC} = 5V$, $V_{EE} = 0V$, $T_A = 0^{\circ}C$ TO $70^{\circ}C$ unless otherwise shown.

PARAMETER	SYMBOL	CONDITIONS	MIN	TYP ¹	MAX	UNITS	NOTES	TEST LEVEL
Supply Voltage	V_{CC}		4.75	5.0	5.25	V		
Power Consumption	P_D		-	240	-	mW		3
		with OEM active	-	340	-	mW		3
Supply Current	I_S		-	44	-	mA		1
		with OEM active	-	58	-	mA		1
Serial Data O/P Current	I_{SDO}	$R_L = 75\Omega$	-	11	-	mA		3
SDI/ \overline{SDI} Common Mode Voltage			-	2.5	-	V		1
AGC+/AGC- Mode Voltage			-	2.7	-	V		1
OEM Bias Potential			-	4.5	-	V		1
SSI/CD Output Current	I_{SOURCE}	$C_{LMAX} = 50pF$ $R_L = \infty$	-	-	18	μA		
		$C_{LMAX} = 50pF$ $R_L = 5k\Omega$	-	-	110	μA		
	I_{SINK}		-	1.0	1.5	mA		
High Z Input Voltage	V_{HIGH}		2.4	-	-	V		1
	V_{LOW}		-	-	0.8	V		1

TEST LEVELS

- 100% tested at 25°C.
- Guaranteed by design.
- Inferred or co-related value.

NOTES

- Typical values are parametric norms at 25°C.

AC ELECTRICAL CHARACTERISTICS

V_{CC} = 5V, V_{EE} = 0V, T_A = 0°C TO 70°C unless otherwise shown.

PARAMETER	SYMBOL	CONDITIONS	MIN	TYP ¹	MAX	UNITS	NOTES	TEST LEVEL
Data Rate			143	-	540	Mb/s		1
Output Signal Swing	V _{SDO}	R _L = 75Ω	700	850	1000	mV		1
Additive Jitter	t _J	270Mb/s, 300m	-	275	-	ps p-p	see Fig 5	5
		540Mb/s, 100m	-	200	-	ps p-p		5
Output Rise and Fall Times (20-80%)	t _r , t _f		0.5	0.65	-	ns		3
Output Duty Cycle Distortion			-	30	-	ps		2
Input Resistance	R _{IN}	SDI, $\overline{\text{SDI}}$	-	10	-	kΩ		2
Input Capacitance	C _{IN}	SDI, $\overline{\text{SDI}}$	-	1.0	-	pF		2
Carrier Detect Response Time	t _{CDON}	Carrier Applied R _L = ∞, C _L ≤ 50pF on SSI/CD	-	3	-	μs		2
	t _{CDOFF}	Carrier Removed R _L = ∞, C _L ≤ 50pF on SSI/CD	-	30	-	μs		2
High Z Response Time	t _{rHIGHZ}		-	17	-	ns		2
Input Return Loss		at 270MHz	15	20	-	dB	see Fig 8	3
Maximum Equalizer Gain	A _{EQ}	at 200MHz	-	40	-	dB	see Fig 4	3, 5

TEST LEVELS

- 100% tested at 25°C.
- Guaranteed by design.
- Inferred or co-related value.

4. Evaluated using test setup Figure 1.
5. Evaluated using test setup Figure 2.

NOTES

- Typical values are parametric norms at 25°C.

TEST SETUP

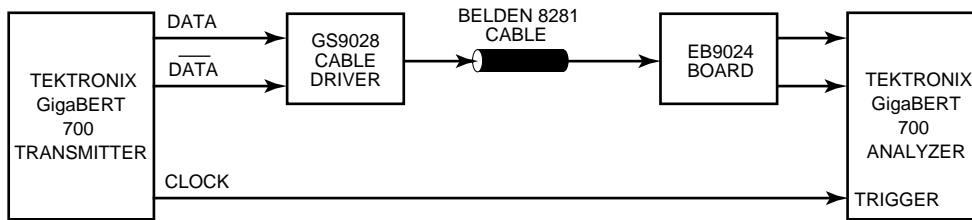

Fig. 1 Test Setup for Figure 3.

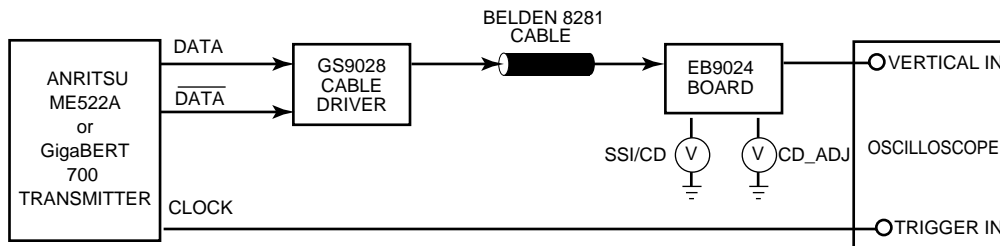
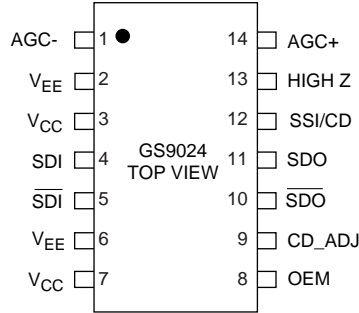

Fig. 2 Test Setup for Figures 4, 5, 6, 7, 10 and 11.

PIN CONNECTIONS



GS9024

PIN DESCRIPTIONS

NUMBER	SYMBOL	TYPE	DESCRIPTION
1, 14	AGC-, AGC+	I	External AGC capacitor.
4, 5	SDI/ $\overline{\text{SDI}}$	I	Differential serial digital data inputs.
8	OEM	O	Output 'Eye' monitor. OEM is a single ended current mode output and requires an external 50 Ω pullup resistor.
9	CD_ADJ	I	Carrier detect threshold adjust.
10, 11	$\overline{\text{SDO}}$ /SDO	O	Equalized serial digital data outputs.
12	SSI/CD	O	Signal strength indicator/Carrier Detect.
13	HIGH Z	I	The $\overline{\text{SDO}}$ /SDO outputs are High Z when this pin is HIGH. If High Z functionality is not used, this input can be left floating or tied LOW.

TYPICAL PERFORMANCE CURVES ($V_S = 5V$, $T_A = 25^\circ C$ unless otherwise shown.)

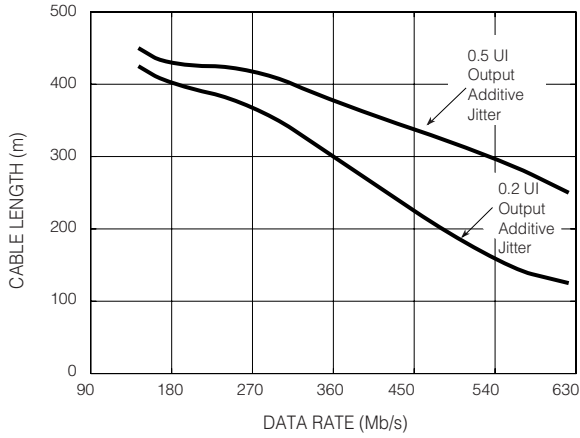

Fig. 3 Maximum Data Rate vs. Cable Length - Belden 8281n (see Test Setup in Figure 1)

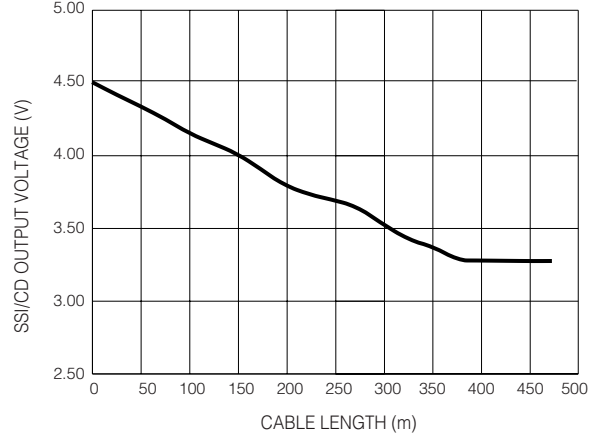

Fig. 6 SSI/CD Voltage vs. Cable Length - Belden 8281 (CD_ADJ = 0V)

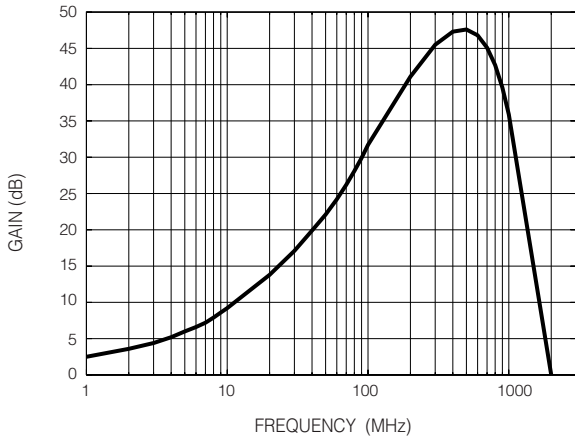

Fig. 4 Equalizer Gain vs. Frequency

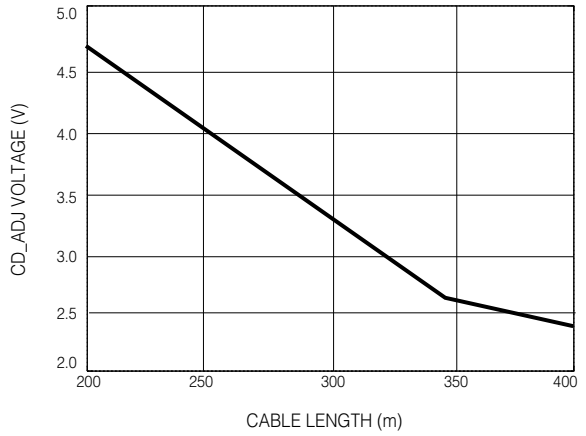

Fig. 7 Carrier Detect Adjust Voltage Threshold Characteristics

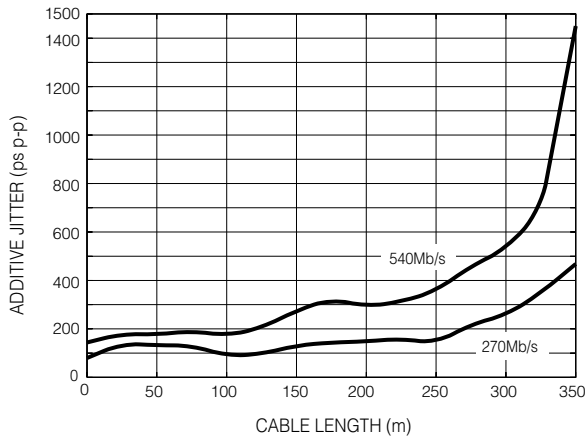
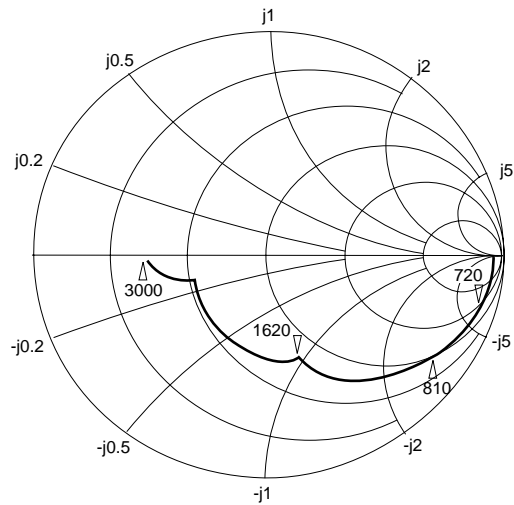

Fig. 5 Additive Jitter vs. Input Cable Length - Belden 8281



Frequencies in MHz, impedances normalized to 50Ω.

Fig. 8 Input Impedance

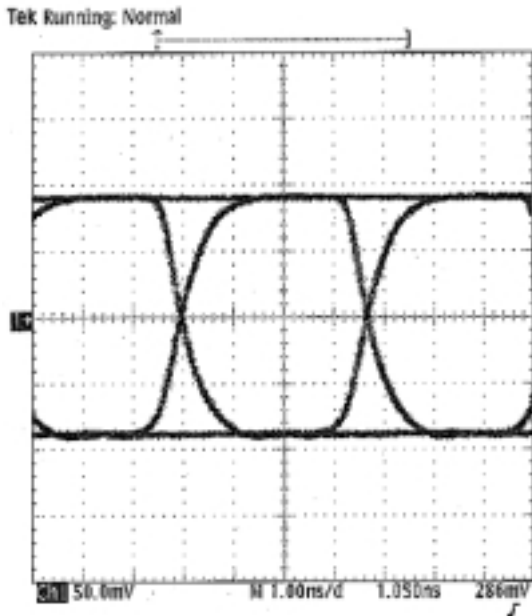

Fig. 9 Output Data Waveform at 270Mb/s, 300m

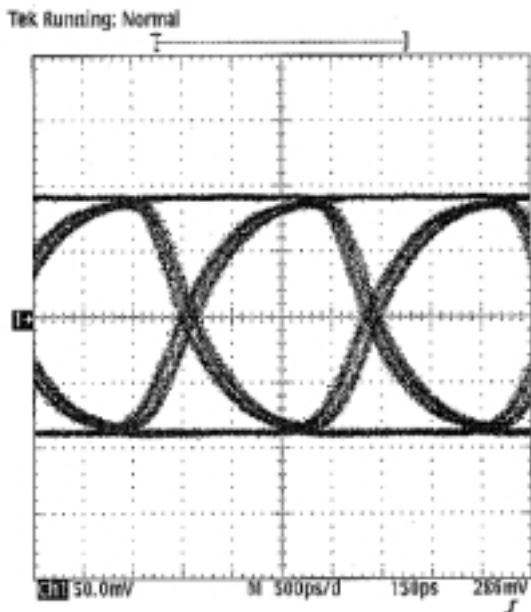

Fig. 10 Output Data Waveform at 540Mb/s, 200m

DETAILED DESCRIPTION

The GS9024 Automatic Cable Equalizer is a bipolar integrated circuit designed to equalize serial digital data signals between 30Mbps and 622Mbps. Powered from a single +5V or -5V supply, the device consumes approximately 240mW of power.

The serial data signal is connected to the input pins (SDI/ $\overline{\text{SDI}}$) either differentially or single ended. The input signal passes through a variable gain equalizing stage whose frequency response closely matches the inverse cable loss characteristic. In addition, the variation of the frequency response with control voltage imitates the

variation of the inverse cable loss characteristic with cable length. The gain stage provides up to 40dB of gain at 200MHz which will typically result in equalization of greater than 350m at 270Mb/s of Belden 8281 cable.

The edge energy of the equalized signal is monitored by a detector circuit which produces an error signal corresponding to the difference between the desired edge energy and the actual edge energy. This error signal is integrated by an external differential AGC filter capacitor (AGC+/AGC-) providing a steady control voltage for the gain stage. As the frequency response of the gain stage is automatically varied by the application of negative feedback, the edge energy of the equalized signal is kept at a constant level which is representative of the original edge energy at the transmitter.

The equalized signal is DC restored, thereby restoring its logic threshold to its corrective level regardless of shifts due to AC coupling. The digital output signals have PECL voltage levels (800mV) and are available at pins $\overline{\text{SDO}}$ and SDO.

1. OUTPUT HIGH Z

A HIGH Z pin allows the data outputs to be put into a high impedance state which disconnects them from the output traces. This feature is ideal for input expansion in router applications as it eliminates the need for input muxes or crosspoints.

2. SIGNAL STRENGTH INDICATION/CARRIER DETECT

The GS9024 incorporates an analog signal strength indicator/carrier detect output (SSI/CD) which indicates both the presence of a carrier and the amount of equalization applied to the signal. The voltage output of this pin versus cable length (signal strength) is shown in Figure 11. With 0m of cable (800mV input signal levels), the SSI/CD output voltage is approximately 4.5V.

As the cable length increases, the SSI/CD voltage decreases linearly providing accurate correlation between the SSI/CD voltage and cable length.

When the signal strength decreases to the level set at the "Carrier Detect Threshold Adjust" pin, the SSI/CD voltage goes to a logic "0" state (0.8V) and can be used to drive other TTL/CMOS compatible logic inputs. In addition, when loss of carrier is detected the $\overline{\text{SDO}}$ /SDO outputs are muted (set to a known static state).

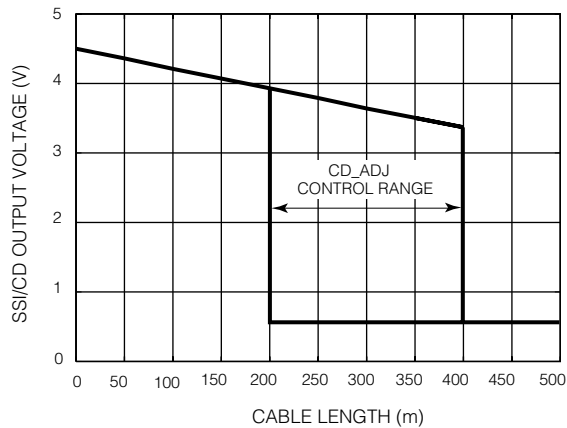

Fig. 11

3. CARRIER DETECT THRESHOLD ADJUST

The threshold level at which loss of carrier is detected is adjustable via external resistors at the CD_ADJ pin. The control voltage at the CD_ADJ pin is set by a simple resistor divider circuit. The threshold level is adjustable from 200m to 350m. By default (no external resistors), the threshold is typically 320m. Connecting this pin to Ground disables the $\overline{\text{SDO}}$ /SDO muting function and allows for maximum possible cable length equalization.

This feature is designed for use in applications such as routers where signal crosstalk and circuit noise cause the equalizer to output erroneous data when no input signal is present. This problem is not solved by using a Carrier Detect function with a fixed internal reference because the signal to noise ratio on the circuit board may be significantly less than the default signal detection level set by the on-chip reference. To solve this problem, the GS9024 provides a user adjustable threshold to meet the unique conditions that exist in each user's application. Override and internal default settings are provided to give the user total flexibility.

4. OUTPUT EYE MONITOR

The GS9024 provides an 'Output Eye Monitor' (OEM) which allows the verification of signal integrity after equalization, prior to reslicing. The OEM pin is an open collector current output that requires an external 50Ω pullup resistor. When the pullup resistor is not used, the OEM block is disabled and the internal OEM circuit is powered down. The OEM provides a 0.25Vp-p signal when driving a 50Ω oscilloscope input.

5. I/O DESCRIPTION

5.1. High Speed Analog Inputs ($\overline{\text{SDI}}$ /SDI)

SDI/ $\overline{\text{SDI}}$ are high impedance inputs which accept differential or single-ended input drive.

Figure 12 shows the recommended interface when a single-ended serial digital signal is used.

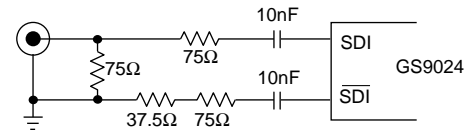

Fig. 12

5.2. High Speed Outputs ($\overline{\text{SDO}}$ /SDO)

$\overline{\text{SDO}}$ /SDO are current mode outputs that require external pullups (see Figure 13). The output signal swings are 800mV when 75Ω resistors are used. A diode can be placed between V_{CC} and the pullups to shift the signal levels down by approximately 0.7 volts. When the output traces are longer than 1 inch, controlled impedance traces should be used. The pullup resistors should be placed at the end of the output traces as they terminate the trace in its characteristic impedance (75Ω).

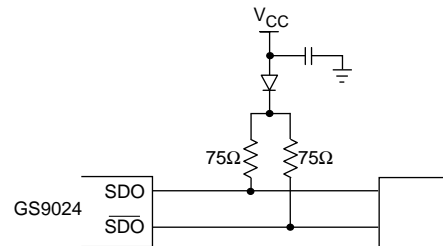
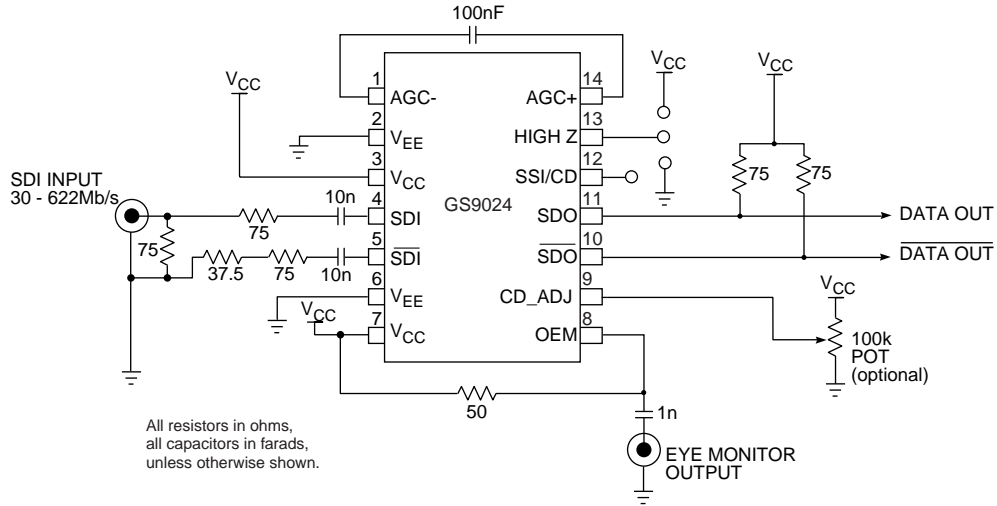

Fig. 13

TYPICAL APPLICATION CIRCUIT



PACKAGE DIMENSIONS

All dimensions in millimeters.

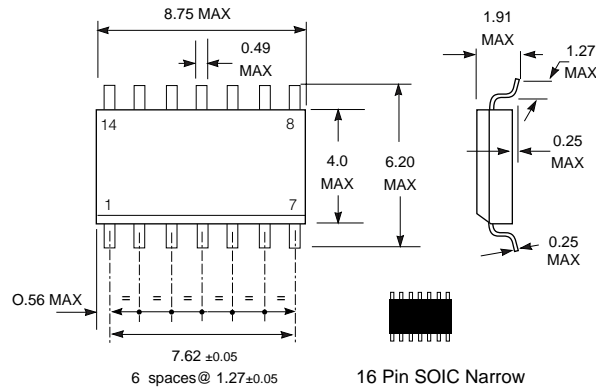

CAUTION
ELECTROSTATIC SENSITIVE DEVICES
DO NOT OPEN PACKAGES OR HANDLE EXCEPT AT A STATIC-FREE WORKSTATION



DOCUMENT IDENTIFICATION
DATA SHEET
The product is in production. Gennum reserves the right to make changes at any time to improve reliability, function or design, in order to provide the best product possible.

REVISION NOTES:
Clarified symbols for pin numbers 10 and 11;
Changed SSI/CD to SSI/CD.
For latest product information, visit www.gennum.com

GENNUM CORPORATION

MAILING ADDRESS:
P.O. Box 489, Stn. A, Burlington, Ontario, Canada L7R 3Y3
Tel. +1 (905) 632-2996 Fax. +1 (905) 632-5946

SHIPPING ADDRESS:
970 Fraser Drive, Burlington, Ontario, Canada L7L 5P5

GENNUM JAPAN CORPORATION
C-101, Miyamae Village, 2-10-42 Miyamae, Suginami-ku
Tokyo 168-0081, Japan
Tel. +81 (03) 3334-7700 Fax. +81 (03) 3247-8839

GENNUM UK LIMITED
25 Long Garden Walk, Farnham, Surrey, England GU9 7HX
Tel. +44 (0)1252 747 000 Fax +44 (0)1252 726 523



LittleDiode supplies new, hard to find or obsolete electronic components and semiconductors all over the world.

With over two million different components listed you are sure to find the part you need.

Feel free to visit us today at our online store:

LittleDiode.com

Looking forward to providing you with the best possible service.