

**EAST/WEST CORRECTION  
FOR RECTANGULAR TV-TUBES**

- LOW POWER DISSIPATION
- PULSE WIDTH MODULATOR FOR SWITCH MODE OPERATION
- OUTPUT SINK CURRENT UP TO 800mA
- OUTPUT SOURCE CURRENT UP TO 100mA
- PARASITIC PARABOLA SUPPRESSION DURING VERTICAL FLYBACK
- VERTICAL CURRENT SENSE INPUTS GROUND COMPATIBLE
- PROGRAMMABLE PARABOLA CURRENT GENERATOR FOR DIFFERENT TV-TUBES
- EXTERNAL KEYSTONE ADJUSTMENT

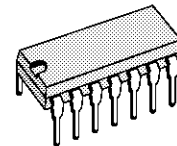

**DIP14**  
(Plastic Package)

**ORDER CODE : TDA8146**

**DESCRIPTION**

The TDA8146 is a monolithic integrated circuit in a 14 pin dual-in-line plastic package.

The TDA8146 is designed for use in the east-west pin-cushion correction by driving a diode modulator in TV and monitor applications.

Since the parabola current generator is programmable the device can operate with different CRTs.

**PIN CONNECTIONS**

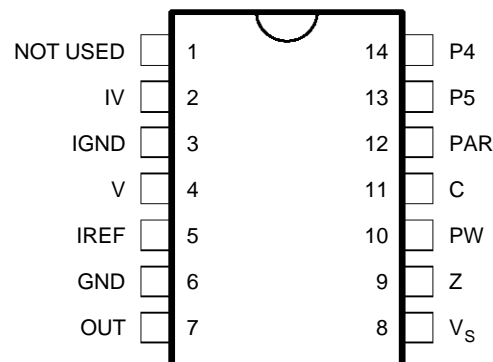

8146-01.EPS

**BLOCK DIAGRAM**

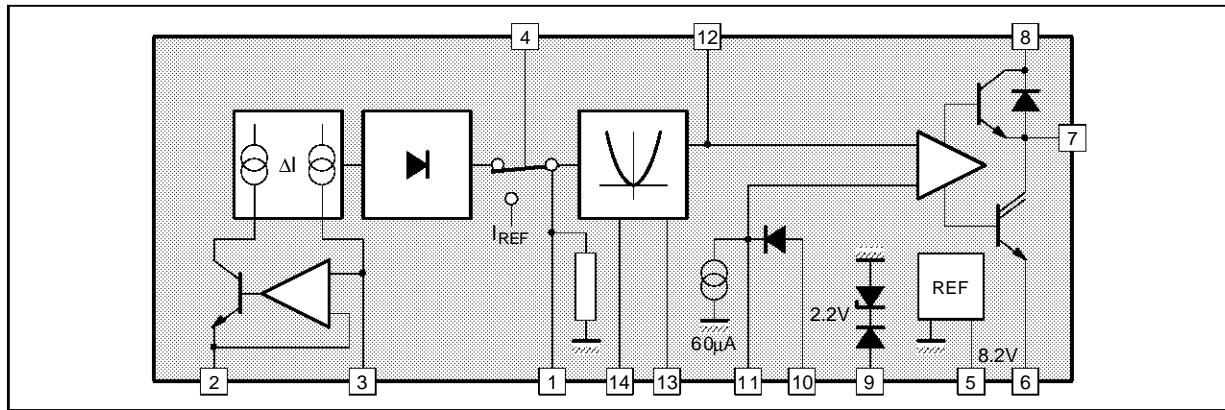

8146-02.EPS

**ABSOLUTE MAXIMUM RATINGS**

Symbol	Parameter	Value	Unit
$I_7$	Output Sink Current	800	mA
$I_7$	Output Source Current	100	mA
$V_S$	Supply Voltage	33	V
$V_4$	Vertical Flyback Input Voltage	- 0.3 to 60	V
$V_{10}$	Input Voltage at Pin 10	- 10 to $V_S$	V
$V_9$	Input Voltage at Pin 9	- 10 to 20	V
$V_{in}$	Input Voltage at all other Pins	- 0.3 to $V_S$	V
$T_{stg}$	Storage Temperature	- 40 to 150	°C
$T_j$	Junction Temperature	0 to 150	°C

8146-01.TBL

**THERMAL DATA**

Symbol	Parameter	Value	Unit
$R_{th(j-a)}$	Junction-ambient Thermal Resistance	Max. 80	°C/W

8146-02.TBL

**ELECTRICAL CHARACTERISTICS**

(refer to test circuit  $V_S = 24V$ ,  $T_j = 25^\circ C$  ; unless otherwise specified)

Symbol	Parameter	Test Conditions	Min.	Typ.	Max.	Unit
$V_S$	Supply Voltage		15	24	29	V
$I_S$	Supply Current	$V_{out} = LOW$		4	7	mA
$V_5$	Reference Voltage			8.2		V
$V_{7L}$	Saturation Voltage	$I_O = 800mA$ Sink		1.2	2	V
$V_{SAT}$	Diode Forward Voltage	$I_O = - 800mA$		1.1	1.7	V
$V_{7H}$	Saturation Voltage	$I_O = 100mA$ Source		0.8	1.25	V
$I_{11}$	Current Sink Pin 11		40	60	80	µA
$V_9$	Zener Voltage	$I_g = 5mA$	20	22	24	V
$V_{4T}$	Vertical Blanking Threshold Voltage		$V_S - 0.5$	$V_S$	$V_S + 0.5$	V
$I_4$	Vertical Blanking Input Current	$V_4 = 50V$	25	50	100	µA
$V_2$	Reference Voltage at Pin 2	$R1 = R2 = 10K$		1.3		V
$V_3$	Reference Voltage at Pin 3			1.3		V
$V_{PARO}$	Parabola Voltage at Pin 12	$\Delta V_{SE} = 0$		9.7		V
$V_C$	Parabola Voltage at Pin 12	$\Delta V_{SE} = + 0.8V$		7.05		V

8146-03.TBL

**ELECTRICAL CHARACTERISTICS** (continued)

(refer to test circuit  $V_S = 24V$ ,  $T_j = 25^\circ C$  ; unless otherwise specified)

Symbol	Parameter	Test Conditions	Min.	Typ.	Max.	Unit
$K_A$	Parabola Coefficient	$K_A = \frac{VA}{VB}$		0.25		
$K_C$	Parabola Coefficient	$K_C = \frac{VC}{VB}$ , S4 + S5 open		1.75		
$K_5$	Parabola Coefficient	$K_5 = \frac{VC5}{VC}$ , S4 or S5 Closed		1.07		
$K_4$	Parabola Coefficient	$K_4 = \frac{VC4}{VC}$ , S4 + S5 Closed		1.17		
$K_S$	Parabola Symmetry	$K_S = \frac{VC}{VD}$	0.94	1.0	1.06	
$K_F$	Flyback Coefficient	$K_F = \frac{VC}{VD}$ , $V_4 = 15V$		1.0		

8146-04.TBL

**TEST CIRCUIT**

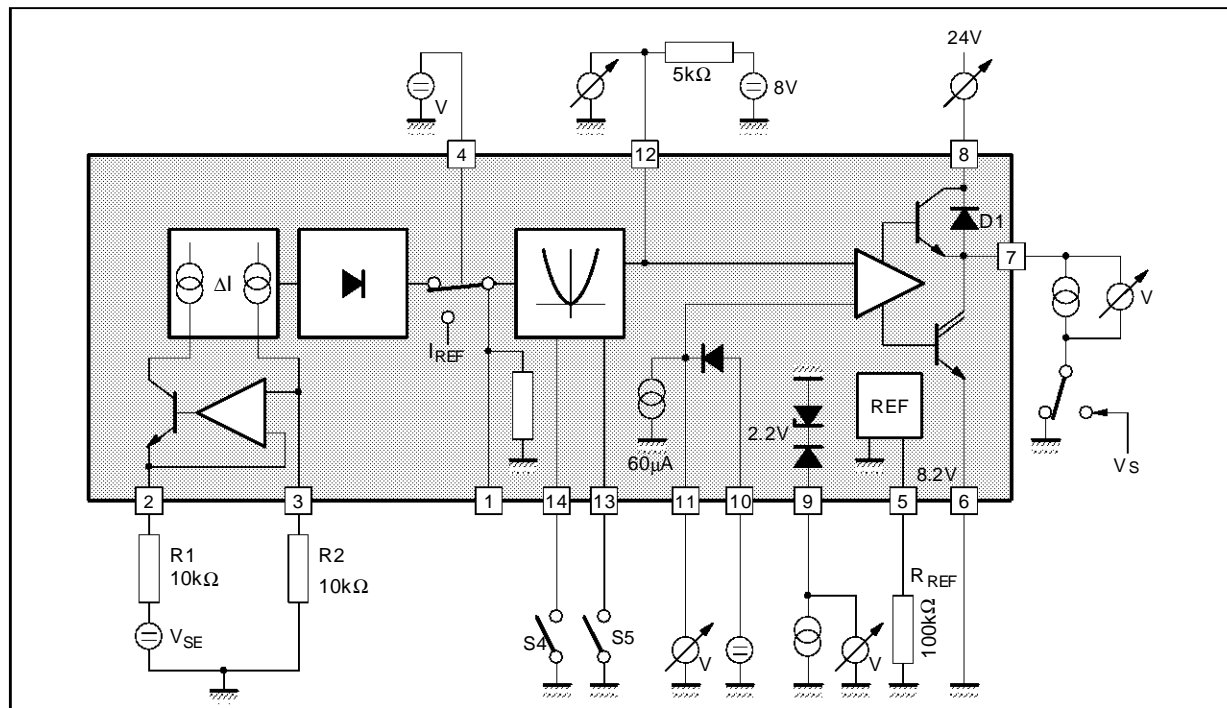

8146-03.EPS

PARABOLA CHARACTERISTICS

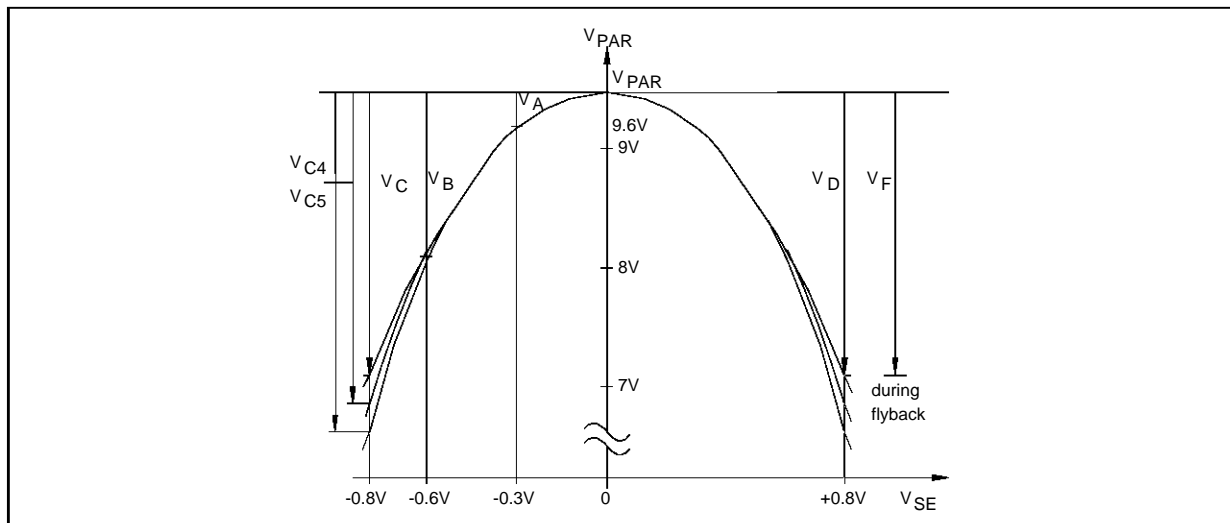

8146-04.EPS

APPLICATION DIAGRAM

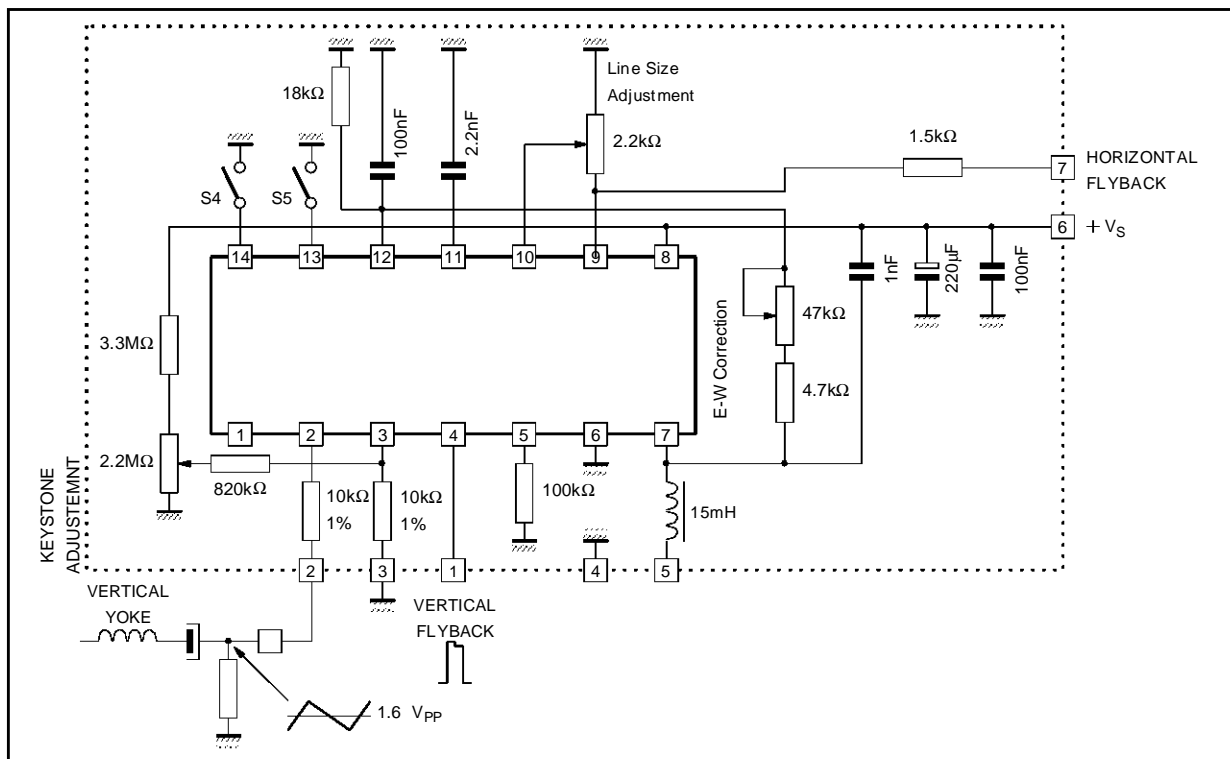

8146-05.EPS

**PACKAGE MECHANICAL DATA**  
14 PINS - PLASTIC DIP

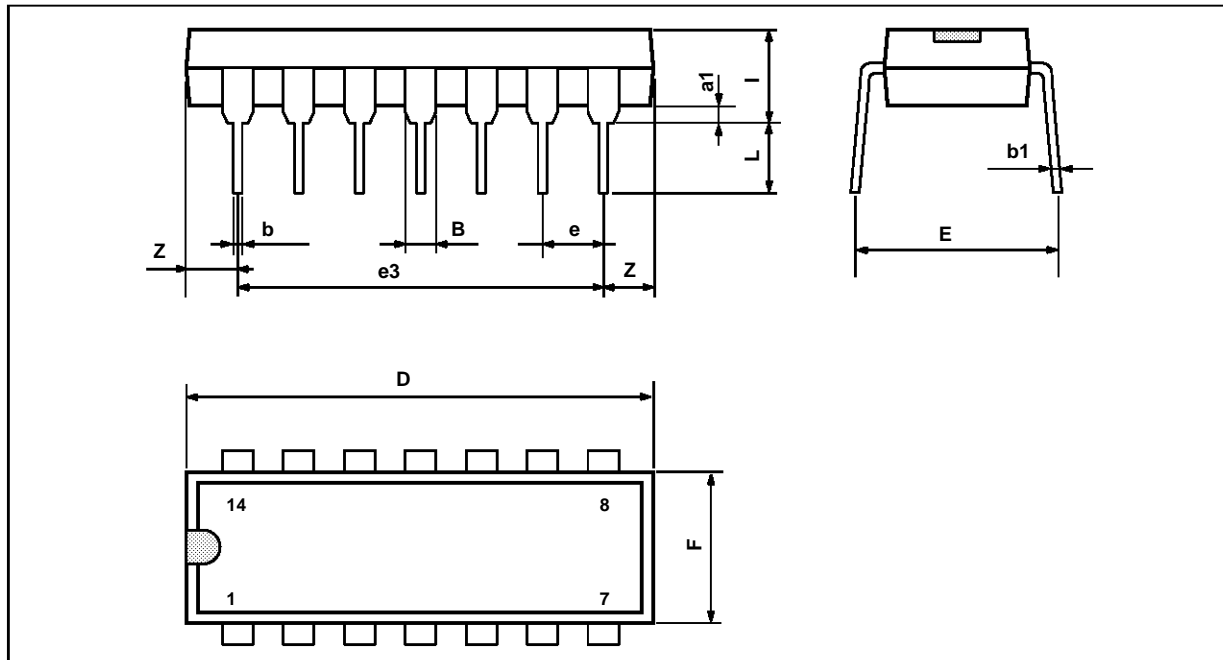

PIM-DIP14.EPS

Dimensions	Millimeters			Inches		
	Min.	Typ.	Max.	Min.	Typ.	Max.
a1	0.51			0.020		
B	1.39		1.65	0.055		0.065
b		0.5			0.020	
b1		0.25			0.010	
D			20			0.787
E		8.5			0.335	
e		2.54			0.100	
e3		15.24			0.600	
F			7.1			0.280
i			5.1			0.201
L		3.3			0.130	
Z	1.27		2.54	0.050		0.100

DIP14.TBL

Information furnished is believed to be accurate and reliable. However, SGS-THOMSON Microelectronics assumes no responsibility for the consequences of use of such information nor for any infringement of patents or other rights of third parties which may result from its use. No licence is granted by implication or otherwise under any patent or patent rights of SGS-THOMSON Microelectronics. Specifications mentioned in this publication are subject to change without notice. This publication supersedes and replaces all information previously supplied. SGS-THOMSON Microelectronics products are not authorized for use as critical components in life support devices or systems without express written approval of SGS-THOMSON Microelectronics.

© 1994 SGS-THOMSON Microelectronics - All Rights Reserved

Purchase of I<sup>2</sup>C Components of SGS-THOMSON Microelectronics, conveys a license under the Philips I<sup>2</sup>C Patent. Rights to use these components in a I<sup>2</sup>C system, is granted provided that the system conforms to the I<sup>2</sup>C Standard Specifications as defined by Philips.

SGS-THOMSON Microelectronics GROUP OF COMPANIES

Australia - Brazil - China - France - Germany - Hong Kong - Italy - Japan - Korea - Malaysia - Malta - Morocco  
The Netherlands - Singapore - Spain - Sweden - Switzerland - Taiwan - Thailand - United Kingdom - U.S.A.