

FEATURES

- two-quadrant video multiplication
- operation from ± 4.5 V to ± 13.2 V supply voltages
- 20 MHz ± 0.1 dB video & control channel bandwidth
- ultra low differential gain & differential phase
- convenient 8 pin package

APPLICATIONS

- Multimedia Graphics Overlay
- Production Switchers
- Linear Keyers

PIN CONNECTIONS

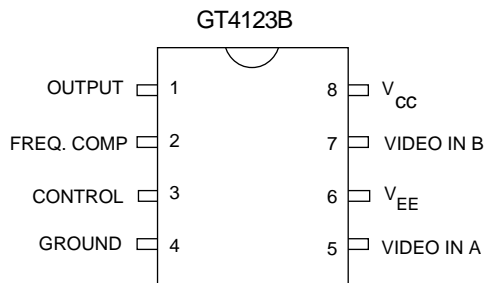

ORDERING INFORMATION

Part Number	Package Type	Temperature Range
GT4123BCDA	8 pin PDIP	0° to 70° C
GT4123BCKA	8 pin SOIC	0° to 70° C
GT4123BCTA	8 pin SOIC Tape	0° to 70° C

DESCRIPTION

The GT4123B is a monolithic dual-channel video multiplier for use in a wide range of applications including broadcast and multimedia.

Featuring two wideband video inputs and a single control input, the GT4123B achieves broadcast quality mixing of two video input signals to a single output by implementing the function:

$$V_O = [(V_C \cdot V_A) + (1 - V_C) \cdot V_B]$$

where V_C is the control input voltage, which may be varied continuously over the range 0 V to 1 V, and V_A and V_B are the video input signals.

The GT4123B is a low power version of the GT4123 and GT4123A Video Multipliers which operates from ± 5 V supply voltages and typically draws only 15 mA of current.

FUNCTIONAL BLOCK DIAGRAM

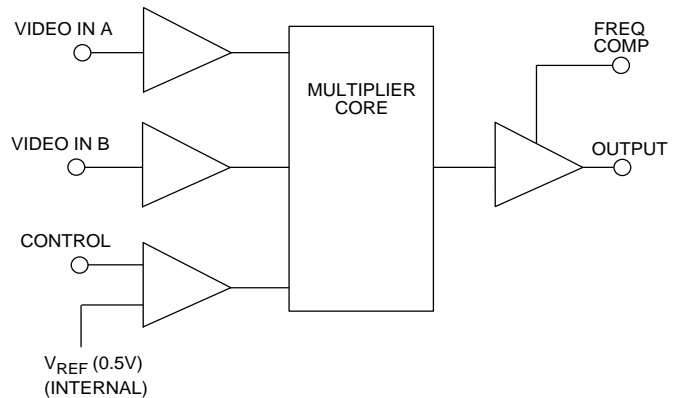

ABSOLUTE MAXIMUM RATINGS

PARAMETER	VALUE/UNITS
Supply Voltage	±13.5 V
Operating Temperature Range	0°C ≤ T _A ≤ 70°C
Storage Temperature Range	-65°C ≤ T _S ≤ 150°C
Lead Temperature (soldering, 10 seconds)	260°C
Video Input Voltage	±5 V
Control Input Voltage	±5 V
Video Input Differential Voltage	±5 V

CAUTION
ELECTROSTATIC
SENSITIVE DEVICES
DO NOT OPEN PACKAGES OR HANDLE
EXCEPT AT A STATIC-FREE WORKSTATION



ELECTRICAL CHARACTERISTICS GT4123B V_S = ±5V, T_A = 0°C to 70°C, R_L = 10kΩ, C_L = 10pF unless otherwise shown.

	PARAMETER	SYMBOL	CONDITIONS	MIN	TYP	MAX	UNITS
POWER SUPPLIES	Supply Voltage	±V _S		±4.5	±5	±13.2	V
	+ Supply Current	I+		-	15	19.5	mA
	- Supply Current	I-		-	15	19.5	mA
SIGNAL PATH	Common Mode Input Signal	V _{IN CM}	Supply Voltage = ±5 V Positive Excursion Limit Negative Excursion Limit	- -	- -	2.2 -3.5	V V
	Bandwidth	BW _{0.05}	±0.05 dB, V _{IN} = 150 mVp-p	10	-	-	MHz
		BW _{0.1}	±0.1 dB, V _{IN} = 150 mVp-p	20	25	-	MHz
	Differential Gain	∂g	V _{IN} = 40 IRE, 0V CM at 3.58 MHz and 4.43 MHz	-	0.01	0.02	%
	Differential Phase	∂p	V _{IN} = 40 IRE, 0V CM at 3.58 MHz and 4.43 MHz	-	0.01	0.03	deg
	PP Signal / RMS Noise	S/N	V _{SIG} = 1 Vp-p,	60	70	-	dB
	Gain	A _V	100 kHz (β = 100%)	-0.02	-0.005	-	dB
	Delay	t _{d SIG}		-	4	10	ns
	Power Supply Rejection Ratio	PSRR	f = 1 kHz	70	-	-	dB
			f = 10 MHz	25	-	-	dB
	Off Isolation & Crosstalk	V _{A or B} /V _O	f _{SIG} = 5 MHz (see note 1)	70	75	-	dB
		V _C /V _{A or B}	f _{SIG} = 5 MHz (see note 2)	80	85	-	dB
	Output Offset		Channel A or Channel B	-	-	±15	mV
	Offset Difference		Channel A - Channel B	0	-	±5	mV
Input Resistance	R _{IN}	f = 1 MHz	100	-	-	kΩ	
Input Capacitance	C _{IN}		-	2.0	-	pF	
Output Resistance	R _{OUT}	f = 1 MHz	-	-	0.50	Ω	
Output Capacitance	C _{OUT}		-	2.0	-	pF	
CONTROL CHANNEL	Bandwidth	BW _{0.1}	at ±0.1 dB, V _{IN} = 150 mVp-p	15	20	-	MHz
	Delay	t _{D CONT}		-	4	10	ns
	Linearity			-	-	1.5	%
	Control Breakthrough		V _C = 0 to 1 V f _C = 1 to 10 MHz	-	-	-35	dB
	Crossfade Balance		V _C = 0 to 1 V f _C = 3.58 MHz	-15	0	+15	mV
	Control Range	V _C		0	-	+1	V

- NOTE:**
- V_A or B = +1 Vp-p, output taken from OUTPUT
 - V_C = +1 Vp-p, output taken from V_A or V_B

DETAILED DESCRIPTION

The GT4123B is a low power two quadrant video multiplier for use in a wide range of applications including broadcast and multimedia.

The internal topology of the device is shown in Figure 1 below.

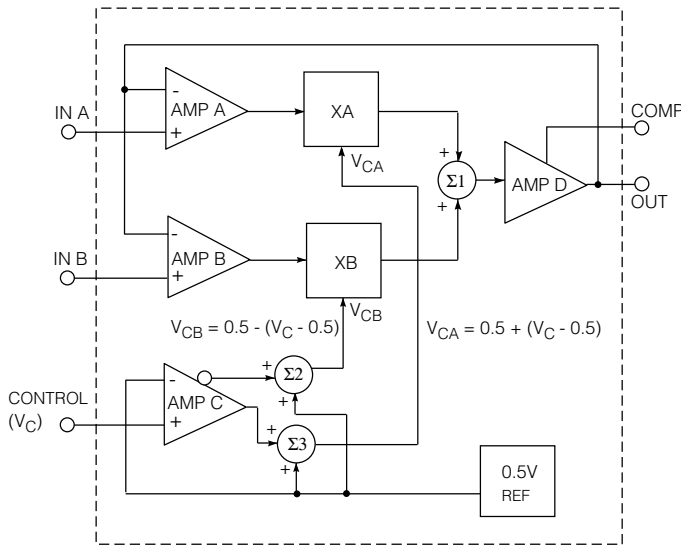

Fig. 1 Functional Block Diagram of the GT4123B

Each input is applied to a differential amplifier (AMP A and AMP B). From the amplifiers, the signals are passed to analog multiplier circuits (XA and XB) whose outputs are the product of the input signals and internally generated controlling voltages V_{CA} and V_{CB} .

The internal control voltages are derived from a unity gain differential amplifier (AMP C) whose outputs (true and invert) are the difference between an internal 0.5 V reference voltage, and the externally applied CONTROL voltage. In addition, the internal DC offset of 0.5 V is applied to the controlling voltage summing circuits $\Sigma 2$ and $\Sigma 3$.

$$\text{Therefore, } V_{CA} = 0.5 \text{ V} + (V_C - 0.5 \text{ V}) \quad \text{and} \\ V_{CB} = 0.5 \text{ V} - (V_C - 0.5 \text{ V})$$

When the control input V_C equals 0.5 volts, $V_{CA} = 0.5 \text{ V}$ and $V_{CB} = 0.5 \text{ V}$, and 50% of each input signal passes to the output of the multiplier stages.

When V_C is less than 0.5 V, V_{CA} reduces and V_{CB} increases in proportion so that less of Channel A and more of Channel B signal is transferred. Similarly, when V_C is greater than 0.5 V, the opposite occurs.

The SPAN or control range is internally set so that a CONTROL voltage of 0 V completely cuts off Channel A and fully turns on Channel B. Similarly, a CONTROL voltage of 1 V will fully turn on Channel A and completely turn off Channel B.

There is a small dead band at either end of the CONTROL input. The amount of dead band is about 100 mV. The CONTROL input can be preceded by an operational amplifier to overcome the dead band and level shift the control signal so that other than 0 to 1 V range can be used. The bandwidth of the CONTROL input is in the order of 20 MHz at $\pm 0.1 \text{ dB}$ to allow for very fast KEY signals.

The linear portion of the transfer characteristic has a linearity of better than 1.5%.

The outputs from the multipliers are applied to an analog summing circuit ($\Sigma 1$) whose output feeds a wideband amplifier (Amp D) and presents the mixed signals to the outside world. The inverting nodes of each input are directly connected to the output.

In this manner, the closed loop gain is nearly unity providing wideband, stable operation. Because the devices have only 8 pins and require virtually no external parts, the GT4123B lends itself to high density, multi-function PC board layouts in devices such as RGB mixers and four layer keyers where close control law tracking is essential.

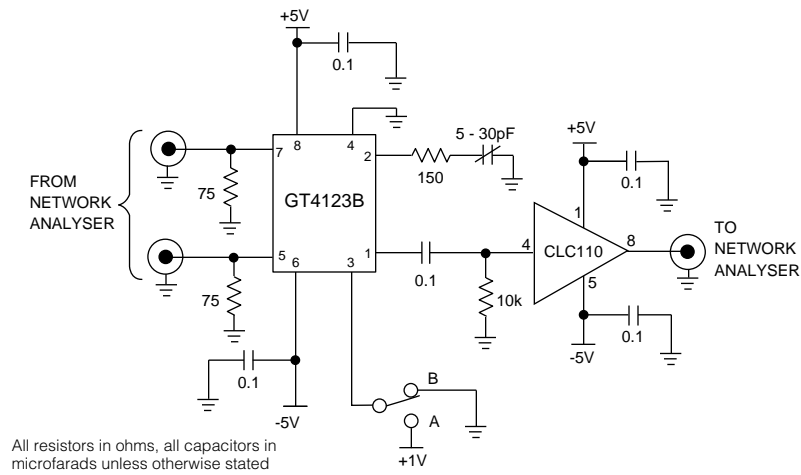

Fig. 2 Frequency Response, Cross Talk, Differential Gain & Phase Test Circuit

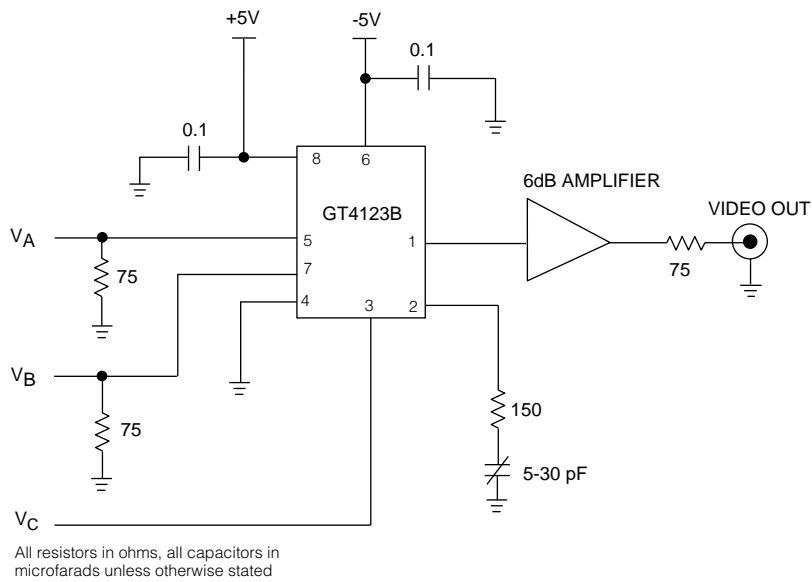

Fig. 3 Typical Application Circuit

GT4123B TYPICAL PERFORMANCE CURVES ($V_s = \pm 5V$, unless otherwise specified)

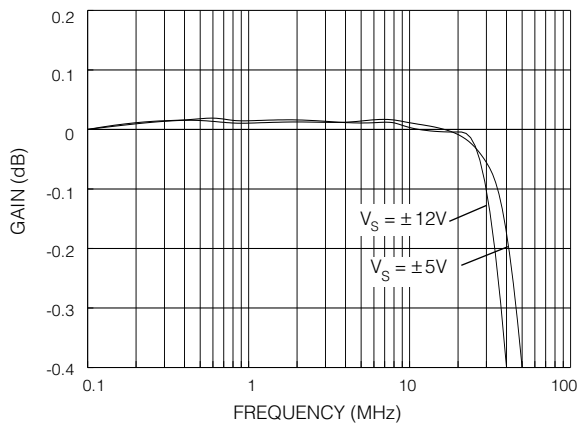

Fig. 4 Frequency Response

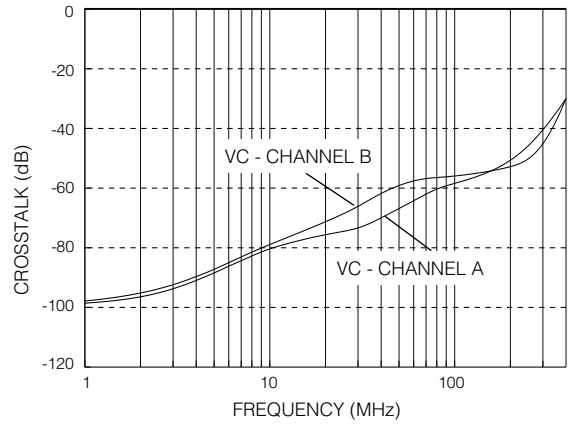

Fig. 5 Crosstalk vs Frequency

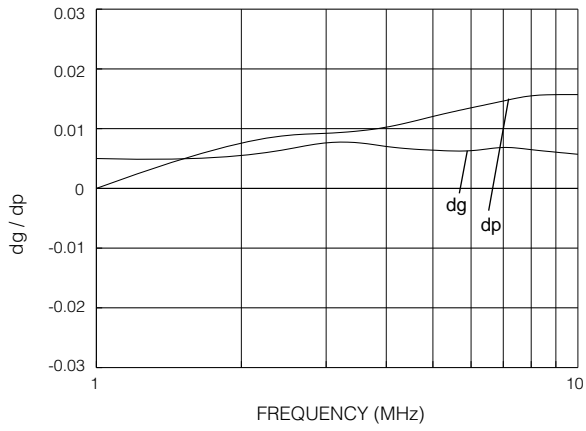

Fig. 6 dg & dp vs Frequency

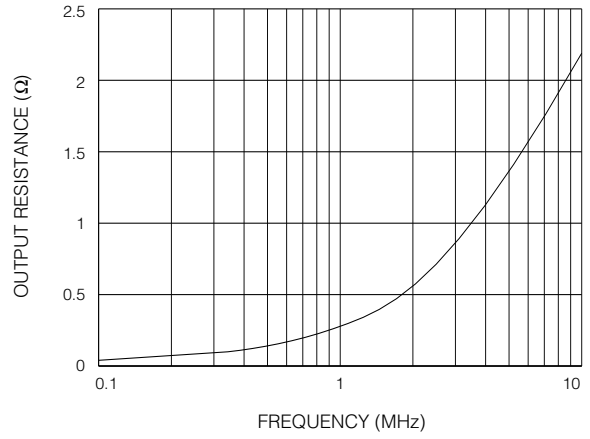

Fig. 7 Output Resistance vs Frequency

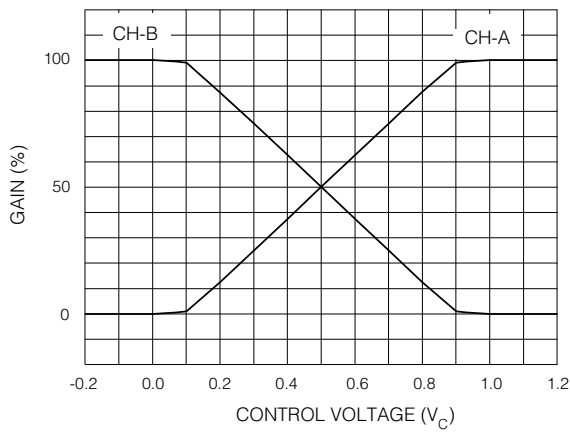

Fig. 8 Control Characteristics

DOCUMENT IDENTIFICATION

PRODUCT PROPOSAL

This data has been compiled for market investigation purposes only, and does not constitute an offer for sale.

ADVANCE INFORMATION NOTE

This product is in a development phase and specifications are subject to change without notice. Gennum reserves the right to remove the product at any time. Listing the product does not constitute an offer for sale.

PRELIMINARY DATA SHEET

The product is in a preproduction phase and specifications are subject to change without notice.

DATA SHEET

The product is in production. Gennum reserves the right to make changes at any time to improve reliability, function or design, in order to provide the best product possible.



LittleDiode supplies new, hard to find or obsolete electronic components and semiconductors all over the world.

With over two million different components listed you are sure to find the part you need.

Feel free to visit us today at our online store:

LittleDiode.com

Looking forward to providing you with the best possible service.