

GTLP8T306 8-Bit LVTTTL-to-GTLP Bus Transceiver

General Description

The GTLP8T306 is an 8-bit bus transceiver that provides LVTTTL to GTLP signal level translation. The device provides a high speed interface between cards operating at LVTTTL logic levels and a backplane operating at GTLP logic levels. High speed backplane operation is a direct result of GTLP's reduced output swing (<1V), reduced input threshold levels and output edge rate control. The edge rate control minimizes bus settling time. GTLP is a Fairchild Semiconductor derivative of the Gunning Transceiver Logic (GTL) JEDEC standard JESD8-3.

Fairchild's GTLP has internal output edge-rate control and is process, voltage, and temperature (PVT) compensated. Its function is similar to BTL and GTL but with different output levels and receiver thresholds. The GTLP output LOW level is typically less than 0.5V, the output HIGH level is 1.5V and the receiver threshold is 1.0V.

Features

- Bidirectional interface between GTL/GTLP and LVTTTL logic levels
- Output Edge Rate Control to minimize noise on the GTLP port
- Power up/down/off high impedance for live insertion
- Standard 245 function
- CMOS technology for low power dissipation
- 5V tolerant inputs and outputs on the A-Port
- Bus-hold data inputs on the A-Port eliminates the need for external pull-up resistors on unused inputs
- LVTTTL compatible driver and control inputs
- Flow through pinout optimizes PCB layout
- Open drain on GTLP to support wired-or connection
- A-Port source/sink -24 mA/+24 mA
- B-Port sink 50 mA
- Recommended Operating Temperature -40°C to +85°C

Ordering Code:

Order Number	Package Number	Package Description
GTLP8T306MTC	MTC24	24-Lead Thin Shrink Small Outline Package (TSSOP), JEDEC MO-153, 4.4mm Wide

Devices also available in Tape and Reel. Specify by appending the suffix letter "X" to the ordering code.

Logic Symbol

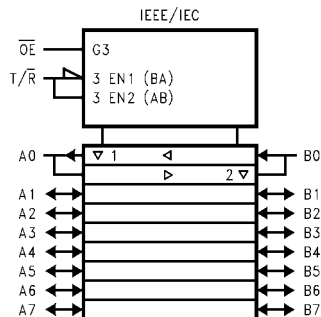

Connection Diagram

\overline{OE}	1	24	T/\overline{R}
V_{CC}	2	23	V_{REF}
A0	3	22	B0
A1	4	21	B1
A2	5	20	B2
A3	6	19	B3
GND	7	18	GND
A4	8	17	B4
A5	9	16	B5
A6	10	15	B6
A7	11	14	B7
GND	12	13	GND

Pin Descriptions

Pin Names	Description
\overline{OE}	Output Enable (Active LOW)
T/\overline{R}	Transmit/Receive Input
A0–A7	Side A Inputs or 3-STATE Outputs
B0–B7	Side B Inputs or 3-STATE Outputs
V_{REF}	GTLP Reference Voltage

Truth Table

Inputs		Output
\overline{OE}	T/\overline{R}	
H	X	HIGH Z on Bus A and Bus B
L	L	Bus B Data to Bus A
L	H	Bus A Data to Bus B

Functional Description

The GTLP8T306 is an 8-bit transceiver providing the standard 245 functionality that supports both GTL and GTLP signal levels.

Data polarity is non-inverting and the data flow direction is controlled by the T/\overline{R} pin. The outputs are enabled to allow data through the device when \overline{OE} is LOW otherwise both the A and B ports are placed in a HIGH impedance state.

Logic Diagram

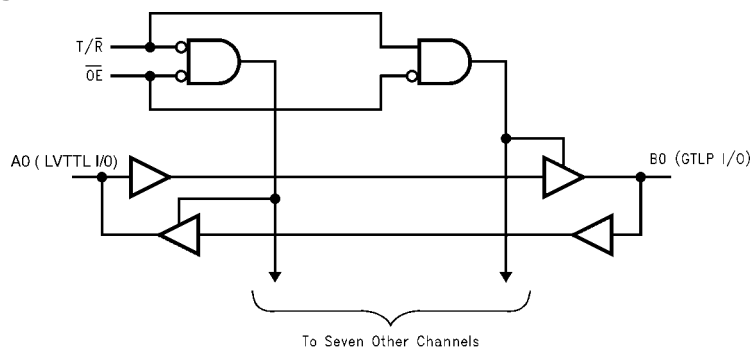

Absolute Maximum Ratings (Note 1)

Supply Voltage (V_{CC})	-0.5V to 7.0V
DC Input Voltage (V_I)	-0.5V to +7.0V
DC Output Voltage (V_O)	
Outputs 3-STATE	-0.5V to +7.0V
Outputs Active (Note 2)	-0.5V to 7.0V
DC Output Sink Current into A-Port I_{OL}	48 mA
DC Output Source Current from A-Port I_{OH}	-48 mA
DC Output Sink Current into B-Port in the LOW State, I_{OL}	100 mA
DC Input Diode Current (I_{IK})	
$V_I < 0V$	-50 mA
DC Output Diode Current (I_{OK})	
$V_O < 0V$	-50 mA
$V_O > V_{CC}$	+50 mA
ESD Rating	>2000V
Storage Temperature (T_{STG})	-65°C to +150°C

Recommended Operating Conditions (Note 3)

Supply Voltage V_{CC}	3.15V to 3.45V
Bus Termination Voltage (V_{TT})	
GTL	1.35V to 1.65V
GTL	1.14V to 1.26V
Input Voltage (V_I) on A-Port and control pins	0V to 5.5V
HIGH Level Output Current (I_{OH})	
A-Port	-24 mA
LOW Level Output Current (I_{OL})	
A-Port	+24 mA
B-Port	+50 mA
Operating Temperature (T_A)	-40°C to +85°C

Note 1: The Absolute Maximum Ratings are those values beyond which the safety of the device cannot be guaranteed. The device should not be operated at these limits. The parametric values defined in the Electrical Characteristics tables are not guaranteed at the absolute maximum rating. The "Recommended Operating Conditions" table will define the conditions for actual device operation.

Note 2: I_O Absolute Maximum Rating must be observed.

Note 3: Unused inputs must be held high or low.

DC Electrical Characteristics

Over Recommended Operating Free-Air Temperature Range, $V_{REF} = 1.0V$ (unless otherwise noted).

Symbol		Test Conditions		Min	Typ (Note 4)	Max	Units	
V_{IH}	B-Port			$V_{REF} + 0.05$		V_{TT}	V	
	Others			2.0			V	
V_{IL}	B-Port			0.0		$V_{REF} - 0.05$	V	
	Others					0.8	V	
V_{REF}	GTLP				1.0		V	
	GTL				0.8		V	
V_{IK}		$V_{CC} = 3.15V$	$I_I = -18\text{ mA}$			-1.2	V	
V_{OH}	A-Port	$V_{CC} = \text{Min to Max}$ (Note 5)	$I_{OH} = -100\ \mu A$	$V_{CC} - 0.2$			V	
		$V_{CC} = 3.15V$	$I_{OH} = -12\text{ mA}$	2.4				
			$I_{OH} = -24\text{ mA}$	2.0				
V_{OL}	A-Port	$V_{CC} = \text{Min to Max}$ (Note 5)	$I_{OL} = 100\ \mu A$			0.2	V	
		$V_{CC} = 3.15V$	$I_{OL} = 24\text{ mA}$			0.5		
	B-Port	$V_{CC} = 3.15V$		$I_{OL} = 40\text{ mA}$			0.4	V
				$I_{OL} = 50\text{ mA}$			0.55	
I_I	A-Port	$V_{CC} = 3.45V$	$V_I = 5.5V$ $V_I = 0V$			20 -20	μA	
	Control Pins	$V_{CC} = 3.45V$	$V_I = 5.5V$ $V_I = 0V$			5 -5	μA	
	B-Port	$V_{CC} = 3.45V$	$V_I = V_{TT}$ $V_I = 0$			5 -5	μA	
I_{OFF}	A-Port	$V_{CC} = 0$	V_I or $V_O = 0$ to $4.5V$			100	μA	
I_I (Hold)	A-Port	$V_{CC} = 3.15V$	$V_I = 0.8V$ $V_I = 2.0V$	75 -20			μA	
I_{OZH}	A-Port	$V_{CC} = 3.45V$	$V_O = 3.45V$			20	μA	
	B-Port			$V_O = 1.5V$				5
I_{OZL}	A-Port	$V_{CC} = 3.45V$	$V_O = 0$			-20	μA	
	B-Port	$V_{CC} = 3.45V$	$V_O = 0.55$			-5		
I_{CC}	A or B Ports	$V_{CC} = 3.45V$ $I_O = 0$ $V_I = V_{CC}$ or GND	Outputs HIGH		7	18	mA	
			Outputs LOW		8	20		
			Outputs Disabled		8	20		
I_{CC} (Note 6)	A-Port and Control Pins	$V_{CC} = 3.45V$ A or Control Inputs at V_{CC} or GND	One Input at $V_{CC} - 0.6V$		0	1	mA	
C_{IN}	Control Pins		$V_I = V_{CC}$ or 0		5		pF	
	A-Port		$V_I = V_{CC}$ or 0		7			
	B-Port		$V_I = V_{CC}$ or 0		9			

Note 4: All typical values are $V_{CC} = 3.3V$ and $T_A = 25^\circ C$.

Note 5: For conditions shown as Min, use the appropriate value specified under recommended operating conditions.

Note 6: This is the increase in supply current for each input that is at the specified LVTTTL voltage level rather than V_{CC} or GND.

AC Electrical Characteristics

Over recommended range of supply voltage and operating free air-temperature, $V_{REF} = 1.0V$ (unless otherwise noted).
 $C_L = 30\text{ pF}$ for B-Port and $C_L = 50\text{ pF}$ for A-Port.

Symbol	From (Input)	To (Output)	Min	Typ (Note 7)	Max	Units
t_{PLH}	An	Bn	1.0	4.0	7.5	ns
t_{PHL}			1.0	5.1	7.5	
t_{PLH}	Bn	An	1.0	5.8	8.3	ns
t_{PHL}			1.0	4.9	8.3	
t_{RISE}	Transition Time, B Outputs (20% to 80%)			2.6		ns
t_{FALL}	Transition Time, B Outputs (20% to 80%)			2.6		ns
t_{RISE}	Transition Time, A Outputs (10% to 90%)			2.5		ns
t_{FALL}	Transition Time, A Outputs (10% to 90%)			2.5		ns
t_{PZH}, t_{PZL}	\overline{OE}	An	1.0	4.5	9.5	ns
t_{PHZ}, t_{PLZ}			1.0	4.9	9.5	
t_{PLH}	\overline{OE}	Bn	1.0	5.4	9.5	ns
t_{PHL}			1.0	6.0	9.5	

Note 7: All typical values are at $V_{CC} = 3.3V$ and $T_A = 25^\circ C$.

Physical Dimensions inches (millimeters) unless otherwise noted

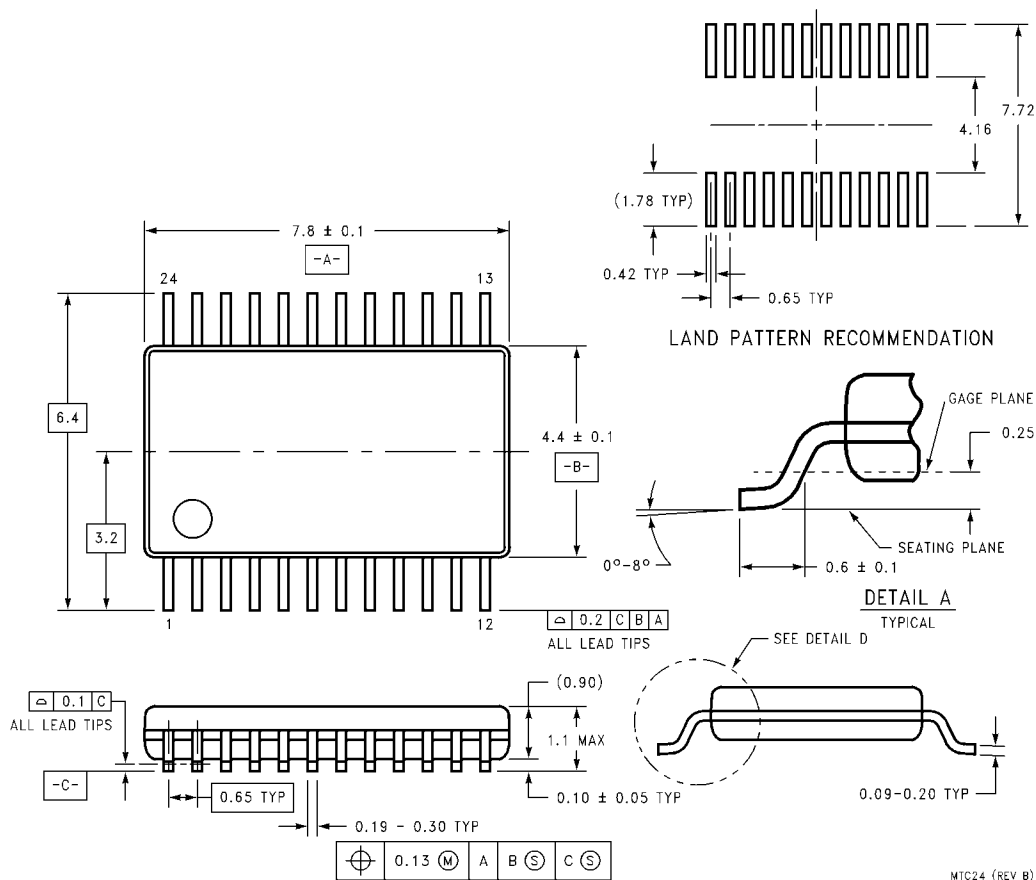

**24-Lead Thin Shrink Small Outline Package, JEDEC MO-153, 4.4mm Wide
Package Number MTC24**

MTC24 (REV B)

LIFE SUPPORT POLICY

FAIRCHILD'S PRODUCTS ARE NOT AUTHORIZED FOR USE AS CRITICAL COMPONENTS IN LIFE SUPPORT DEVICES OR SYSTEMS WITHOUT THE EXPRESS WRITTEN APPROVAL OF THE PRESIDENT OF FAIRCHILD SEMICONDUCTOR CORPORATION. As used herein:

1. Life support devices or systems are devices or systems which, (a) are intended for surgical implant into the body, or (b) support or sustain life, and (c) whose failure to perform when properly used in accordance with instructions for use provided in the labeling, can be reasonably expected to result in a significant injury to the user.
2. A critical component in any component of a life support device or system whose failure to perform can be reasonably expected to cause the failure of the life support device or system, or to affect its safety or effectiveness.

www.fairchildsemi.com