

FEATURES

- 20 ns switching time (toggle)
- make-before-break switching
- 100 MHz at ± 0.1 dB, bandwidth (flattened)
- typically 0.04 dB insertion loss at 1 MHz
- typically 0.03 % differential gain at 3.58 MHz
- typically 0.01 degree differential phase at 3.58 MHz

FUNCTIONAL BLOCK DIAGRAM

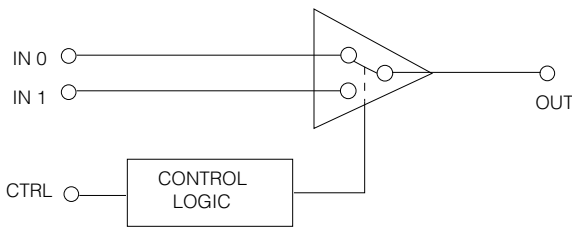

ABSOLUTE MAXIMUM RATINGS

PARAMETER	VALUE
Supply Voltage	± 6.0 V
Operating Temperature Range	0°C to 70°C
Storage Temperature Range	-65°C to 150°C
Lead Temperature (Soldering, 10 Sec)	260°C
Analog Input Voltage (IN 0, IN 1)	$V_{EE} < V_{IN} < V_{CC} + 0.3$ V
Control Input Voltage Range	-5 V $< V_{CTRL} < V_{CC} + 0.3$ V

ORDERING INFORMATION

Part Number	Package Type	Temperature Range
GY4102ACDA	8 pin PDIP	0 - 70°C
GY4102ACKA	8 pin SOIC	0 - 70°C

CIRCUIT DESCRIPTION

The GY4102A is a bipolar, monolithic SPDT video switch incorporating fast control logic. The analog signal path is characterised by low differential gain, low differential phase and low insertion loss, coupled with a ± 0.1 dB bandwidth of typically 100 MHz into a 10 pF load, using an external series resistor.

In demanding video applications the GY4102A features a typical switching glitch of less than 30 mV over a 3 ns period. The device offers toggle rates up to 50 MHz. The control input is TTL and 5 V CMOS compatible.

APPLICATIONS

- Sub-pixel video switching
- Fast data sampling
- Modulation
- Special Effects video switching

PIN CONNECTIONS

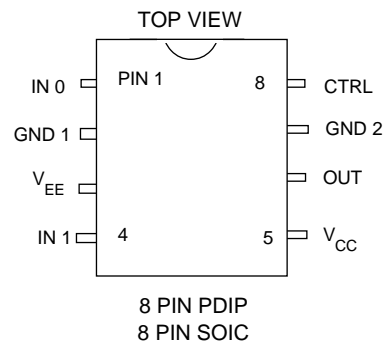

TRUTH TABLE

CTRL	OUTPUT
0	IN 0
1	IN 1

AVAILABLE PACKAGING

- 8 pin PDIP
- 8 pin SOIC

ELECTRICAL CHARACTERISTICS ($V_S = \pm 5V$ DC, $T_A = 0 - 70^\circ\text{C}$, $C_L = 10\text{pF}$, $R_L = 10\text{k}\Omega$ unless otherwise shown)

	PARAMETER	SYMBOL	CONDITIONS	MIN	TYP	MAX	UNITS
DC SUPPLY	Supply Voltage	$\pm V_S$		4.5	5	5.5	V
	Supply Current	I+		-	23	30	mA
		I-			-	25	32
LOGIC	Control Input Bias	I_{CTRL}	Control = 1	-	5	25	μA
	Logic Level threshold	V_{LOGIC}	1	2	-	-	V
			0	-	-	0.8	V
STATIC	Analog Input Bias Current	I_{BIAS}	Selected channel	-	12	30	μA
	Deselected channel		-	26	60	μA	
	Signal Voltage Swing	V_{SIG}	Extremes before clipping occurs	-1.5	-	+3	V
	Output Offset Voltage	V_{OS}	$T_A = 25^\circ\text{C}$	-6	+4	+14	mV
	Output Offset Voltage	$V_{OSCH-CH}$	$T_A = 25^\circ\text{C}$ channel to channel	-	1	5	mV
	Output Offset Drift	$\Delta V_{OS}/T$		-	+93	+200	$\mu\text{V}/^\circ\text{C}$
DYNAMIC	Input Resistance	R_{IN}	Channel On	500	-	-	$\text{k}\Omega$
	Input Capacitance	C_{IN}	Channel On	1.3	-	-	pF
	Frequency Response		DC - 100 MHz $R_S = 33\ \Omega$	-	± 0.2	-	dB
	Flatness		DC - 8 MHz $R_S = 33\ \Omega$	-	-	± 0.01	dB
	Insertion Loss	I.L.	$f = 1\text{ MHz}$	-	0.04	-	dB
	Differential Gain	dg	$f = \text{colorburst } 3.58 \text{ or } 4.43\text{ MHz}$	-	0.03	-	%
	Differential Phase	dp	$f = \text{colorburst } 3.58 \text{ or } 4.43\text{ MHz}$	-	0.01	-	degrees
	Crosstalk (all hostile)	$XTALK_{AH}$	$f = 10\text{ MHz}$ see fig. 3	75	80	-	dB
	Slew Rate	+SR	$V_{IN} = 2\text{ Vp-p}$ $T_A = 25^\circ\text{C}$	400	620	-	$\text{V}/\mu\text{s}$
-SR		250		330	-	$\text{V}/\mu\text{s}$	

SWITCHING CHARACTERISTICS ($V_S = \pm 5V$, $T_A = 0 - 70^\circ\text{C}$, $C_L = 10\text{pF}$, $R_S = 33\ \Omega$, $R_L = 10\text{k}\Omega$)

PARAMETER	SYMBOL	CONDITIONS	MIN	TYP	MAX	UNITS	
Delay Time (see Figure 7)	$t_{d(on1)}$	$V_{SIG} = 0 - 1\text{ V}$	-	5.4	9	ns	
	$t_{d(on2)}$		-	8.2	13	ns	
	$t_{d(off1)}$	$V_{SIG} = 1 - 0\text{ V}$	-	6	11	ns	
	$t_{d(off2)}$		-	12.5	22	ns	
Settling Time (see Figure 7a)	$t_{S(on)}$	To 0.5 IRE on 0 to 1 V output, $T_A = 25^\circ$	-	9	15	ns	
(see Figure 7b)	$t_{S(off)}$	To 0.5 IRE on 1 to 0 V output, $T_A = 25^\circ\text{C}$	-	7	15	ns	
Switching Transient * (Unfiltered)		POS.	Amplitude	-	+30	+50	mV
			Duration	-	3	5	ns
		NEG.	Amplitude	-	-20	-30	mV
			Duration	-	2	3	ns

* CH0 = CH1 = GND

TYPICAL PERFORMANCE CURVES FOR GY4102A

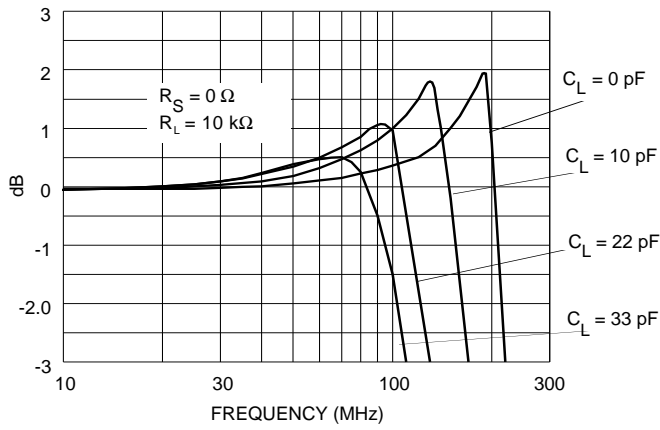

Fig. 1 GY4102A Frequency Response

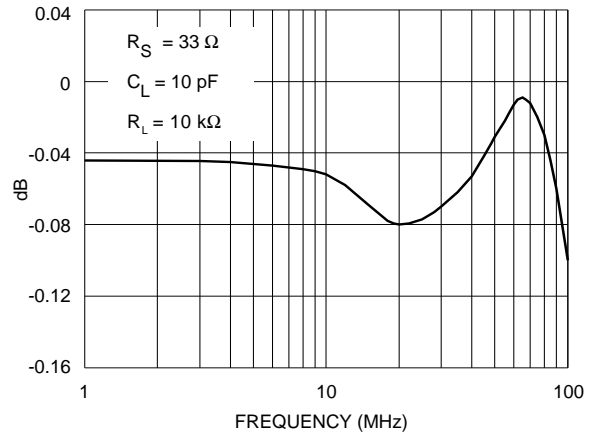

Fig. 2 GY4102A Flattened Frequency Response

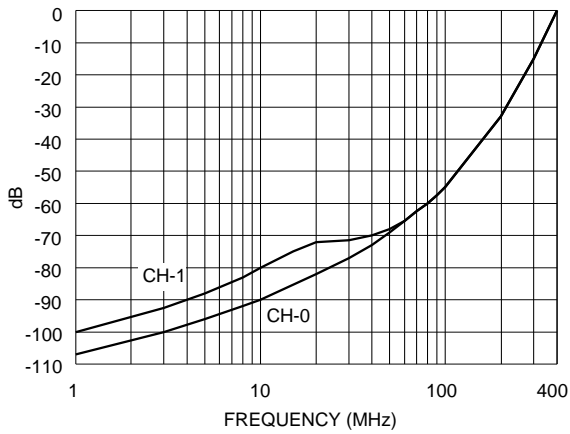

Fig. 3 GY4102A Crosstalk vs Frequency

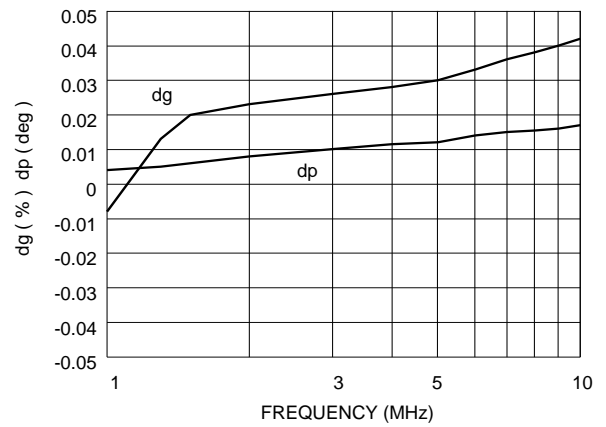
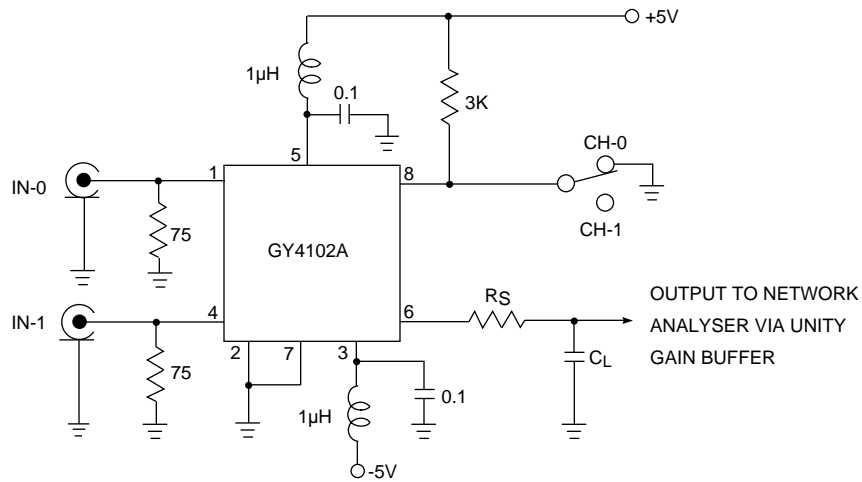

Fig. 4 GY4102A Differential Gain & Phase

An evaluation board and application note on the GY4102A is available.
Please quote EB4102 for the board and AN 520 - 2 for the application note.
There is no charge for these items.

GY4102A TEST CIRCUITS



All resistors in ohms, all capacitors in microfarads unless otherwise stated

Fig. 5 Frequency Response

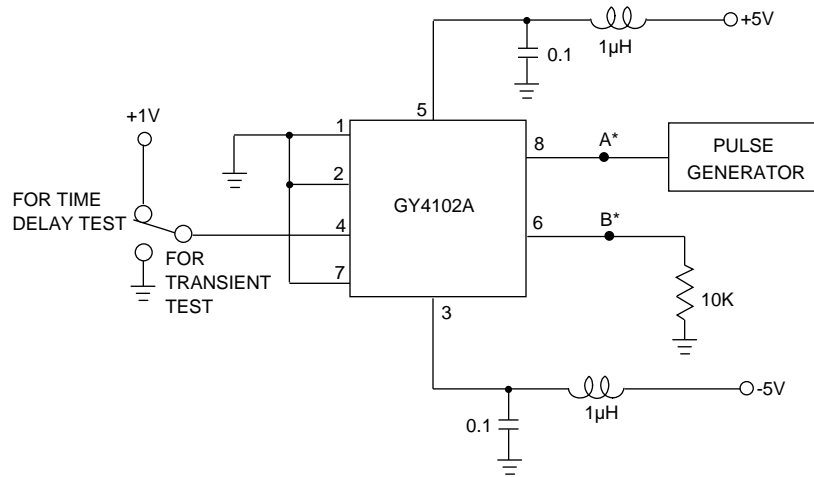

*USE ULTRA LOW CAPACITANCE SCOPE PROBES AT POINTS A & B

PULSE GENERATOR CHARACTERISTICS $t_r = t_f \leq 1 \text{ ns}$ $V_o = 5 \text{ V}$ $p_{rr} \leq 20 \text{ MHz}$

All resistors in ohms, all capacitors in microfarads unless otherwise stated

Fig. 6 Switching Transient / Time Delays

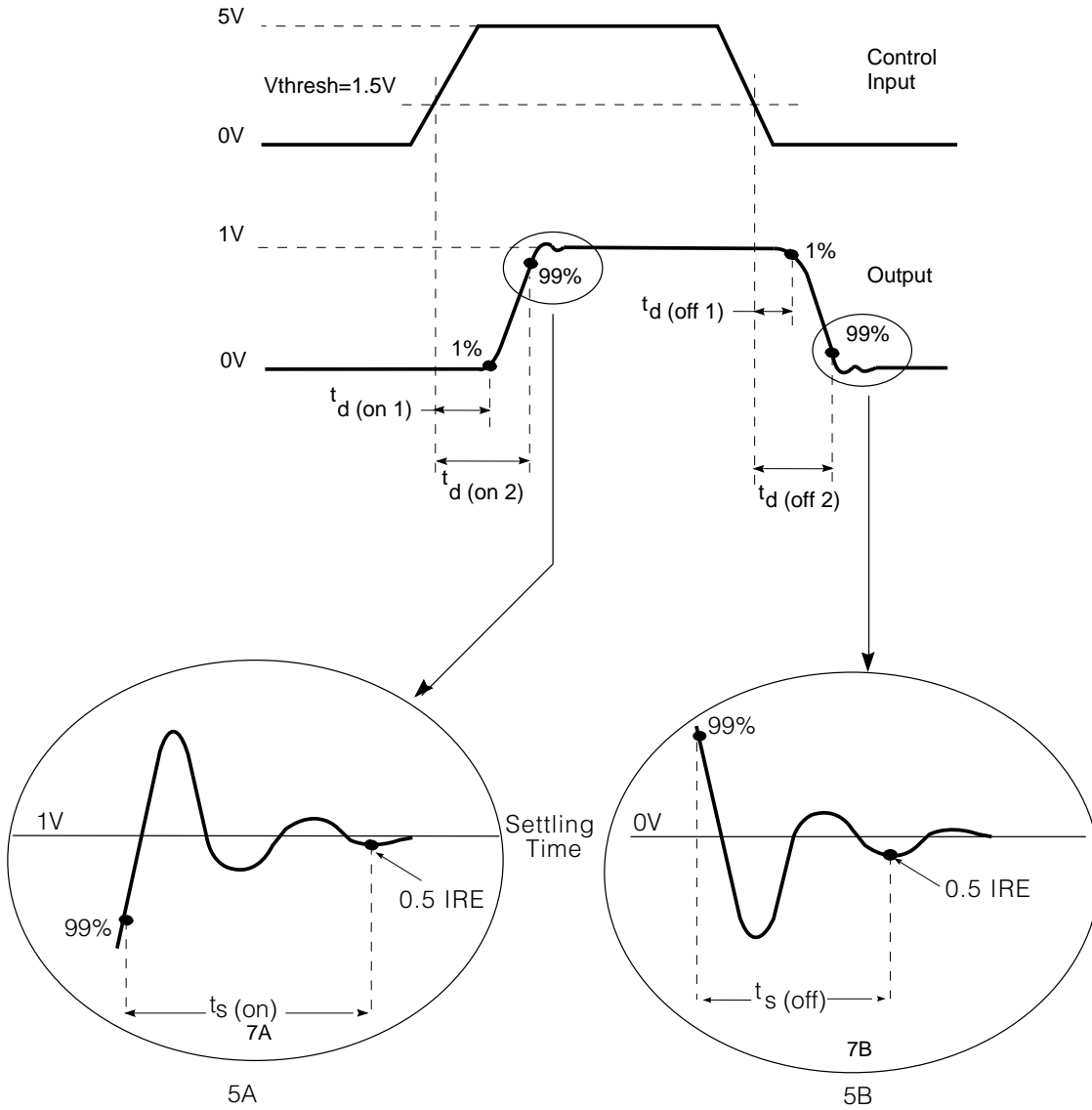



Fig. 7 Delay Time

CAUTION
ELECTROSTATIC
SENSITIVE DEVICES
DO NOT OPEN PACKAGES OR HANDLE
EXCEPT AT A STATIC-FREE WORKSTATION



DOCUMENT IDENTIFICATION

PRODUCT PROPOSAL

This data has been compiled for market investigation purposes only, and does not constitute an offer for sale.

ADVANCE INFORMATION NOTE

This product is in development phase and specifications are subject to change without notice. Gennum reserves the right to remove the product at any time. Listing the product does not constitute an offer for sale.

PRELIMINARY DATA SHEET

The product is in a preproduction phase and specifications are subject to change without notice.

DATA SHEET

The product is in production. Gennum reserves the right to make changes at any time to improve reliability, function or design, in order to provide the best product possible.

Gennum Corporation assumes no responsibility for the use of any circuits described herein and makes no representations that they are free from patent infringement.

© Copyright February 1991 Gennum Corporation . Revision Date: January 1993. All rights reserved. Printed in Canada.



LittleDiode supplies new, hard to find or obsolete electronic components and semiconductors all over the world.

With over two million different components listed you are sure to find the part you need.

Feel free to visit us today at our online store:

LittleDiode.com

Looking forward to providing you with the best possible service.