

H11AG1

H11AG2

H11AG3

DESCRIPTION

The H11AG series consists of a Gallium-Aluminum-Arsenide IRED emitting diode coupled with a silicon phototransistor in a dual in-line package. This device provides the unique feature of the high current transfer ratio at both low output voltage and low input current. This makes it ideal for use in low power logic circuits, telecommunications equipment and portable electronics isolation applications.

FEATURES

- High efficiency low degradation liquid epitaxial IRED
- Logic level compatible, input and output currents, with CMOS and LS/TTL
- High DC current transfer ratio at low input currents
- Underwriters Laboratory (UL) recognized File #E90700

APPLICATIONS

- CMOS driven solid state reliability
- Telephone ring detector
- Digital logic isolation

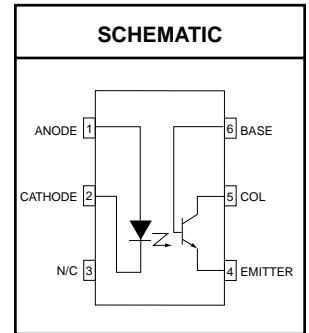
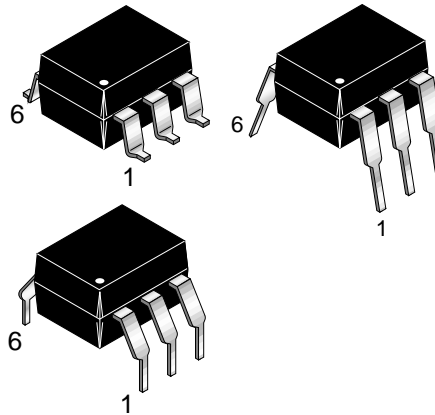

ABSOLUTE MAXIMUM RATINGS

Parameters	Symbol	Device	Value	Units
TOTAL DEVICE				
Storage Temperature	T _{STG}	All	-55 to +150	°C
Operating Temperature	T _{OPR}	All	-55 to +100	°C
Lead Solder Temperature	T _{SOL}	All	260 for 10 sec	°C
Total Device Power Dissipation @ 25°C (LED plus detector) Derate Linearly From 25°C	P _D	All	260	mW
			3.5	mW/°C
EMITTER				
Continuous Forward Current	I _F	All	50	mA
Reverse Voltage	V _R	All	6	V
Forward Current - Peak (1 μs pulse, 300 pps)	I _{F(pk)}	All	3.0	A
LED Power Dissipation 25°C Ambient Derate Linearly From 25°C	P _D	All	75	mW
			1.0	mW/°C
DETECTOR				
Detector Power Dissipation @ 25°C Derate Linearly from 25°C	P _D	All	150	mW
			2.0	mW/°C
Continuous Collector Current		All	50	mA

H11AG1

H11AG2

H11AG3

ELECTRICAL CHARACTERISTICS ($T_A = 0-70^\circ\text{C}$ Unless otherwise specified.)

INDIVIDUAL COMPONENT CHARACTERISTICS

Parameters	Test Conditions	Symbol	Device	Min	Typ	Max	Units
EMITTER							
Input Forward Voltage	$I_F = 1 \text{ mA}$	V_F	All			1.5	V
Reverse Leakage Current	$V_R = 5 \text{ V}, T_A = 25^\circ\text{C}$	I_R	All			10	μA
	$V_R = 5 \text{ V}, T_A = 70^\circ\text{C}$	I_R	All			100	μA
Capacitance	$V = 0, f = 1.0 \text{ MHz}$	C_J	All			100	pF
DETECTOR							
Breakdown Voltage							
Collector to Emitter	$I_C = 1.0 \text{ mA}, I_F = 0$	BV_{CEO}	All	30			V
Collector to Base	$I_C = 100 \mu\text{A}, I_F = 0$	BV_{CBO}	All	70			V
Emitter to Collector	$I_C = 100 \mu\text{A}, I_F = 0$	BV_{ECO}	All	7			V
Leakage Current							
Collector to Emitter	$V_{CE} = 10 \text{ V}, I_F = 0$	I_{CEO}	All		5	10	μA
Capacitance	$V_{CE} = 10 \text{ V}, f = 1 \text{ MHz}$	C_{CE}	All		2		pF

ISOLATION CHARACTERISTICS

Parameters	Test Conditions	Symbol	Min	Typ	Max	Units
Input-Output Isolation Voltage	$I_{I-0} \leq 1 \mu\text{A}, t = 1 \text{ min.}$	V_{ISO}	5300			Vac(rms)

TRANSFER CHARACTERISTICS ($T_A = 25^\circ\text{C}$ Unless otherwise specified.)

DC Characteristics	Test Conditions	Symbol	Device	Min	Typ	Max	Units
Current Transfer Ratio	$I_F = 1 \text{ mA}, V_{CE} = 5 \text{ V}$	CTR	H11AG1	300			%
			H11AG2	200			
			H11AG3	100			
	$I_F = 1 \text{ mA}, V_{CE} = 0.6 \text{ V}$	CTR	H11AG1	100			
			H11AG2	50			
			H11AG3	20			
$I_F = 0.2 \text{ mA}, V_{CE} = 1.5 \text{ V}$	CTR	H11AG1	100				
		H11AG2	50				
Saturation Voltage	$I_F = 2.0 \text{ mA}, I_C = 0.5 \text{ mA}$	$V_{CE(SAT)}$	All			.40	V
AC Characteristics							
Non-Saturated Switching Times							
Turn-On Time	$R_L = 100 \Omega, I_F = 1 \text{ mA}, V_{CC} = 5 \text{ V}$	t_{on}	All		5		μS
Turn-Off Time	$R_L = 100 \Omega, I_F = 1 \text{ mA}, V_{CC} = 5 \text{ V}$	t_{off}	All		5		μS

H11AG1

H11AG2

H11AG3

Figure 1. LED Forward Voltage vs. Forward Current

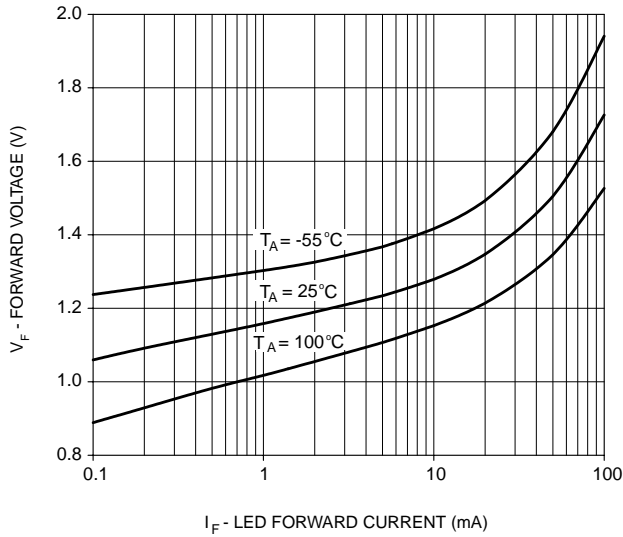

Figure 2. Normalized Current Transfer Ratio vs. Forward Current

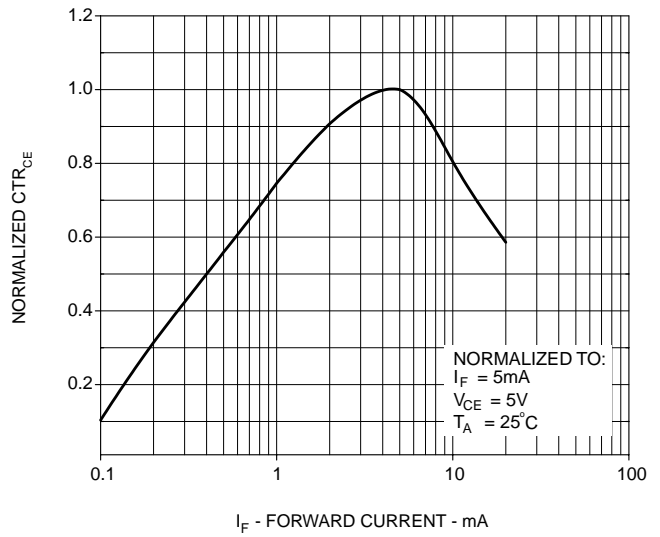

Figure 3. Normalized CTR vs. Temperature

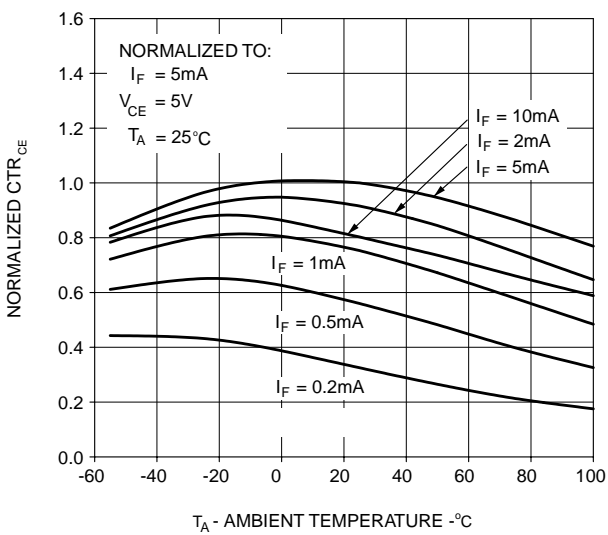
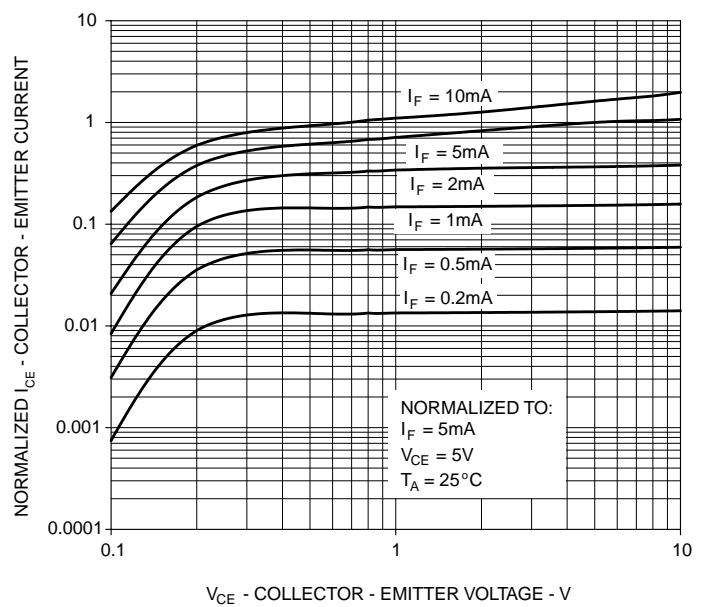

Figure 4. Normalized Collector vs. Collector - Emitter Voltage



H11AG1

H11AG2

H11AG3

Figure 5. Normalized Collector Base Photocurrent Ratio vs. Forward Current

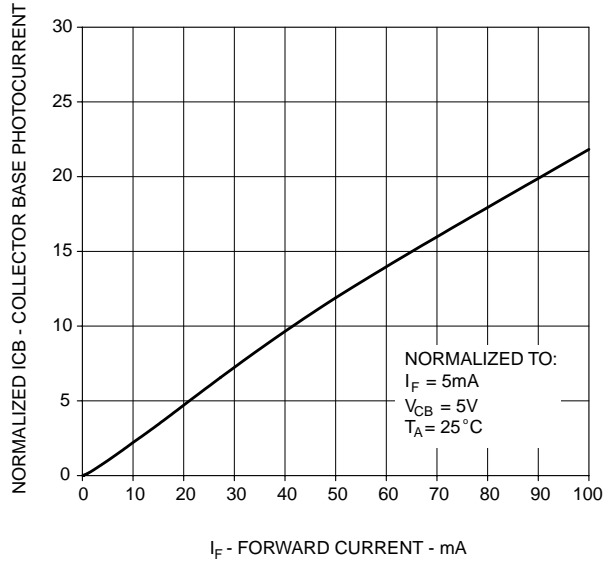

Figure 6. Normalized Collector - Base Current vs. Temperature

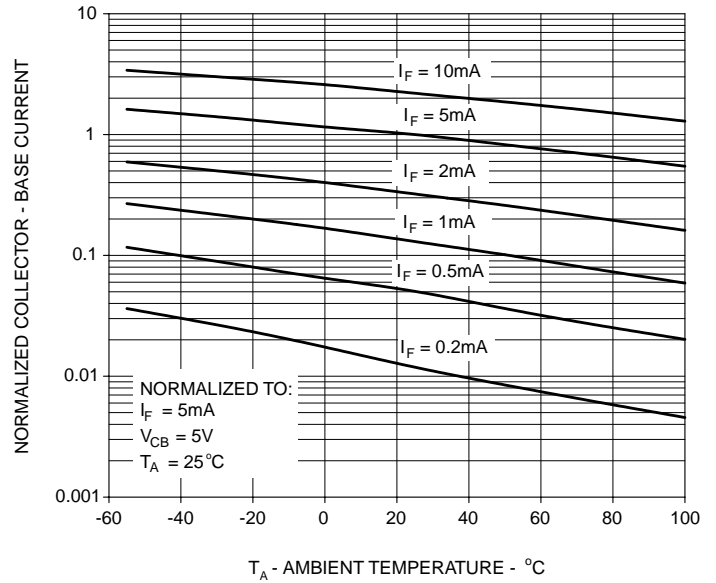
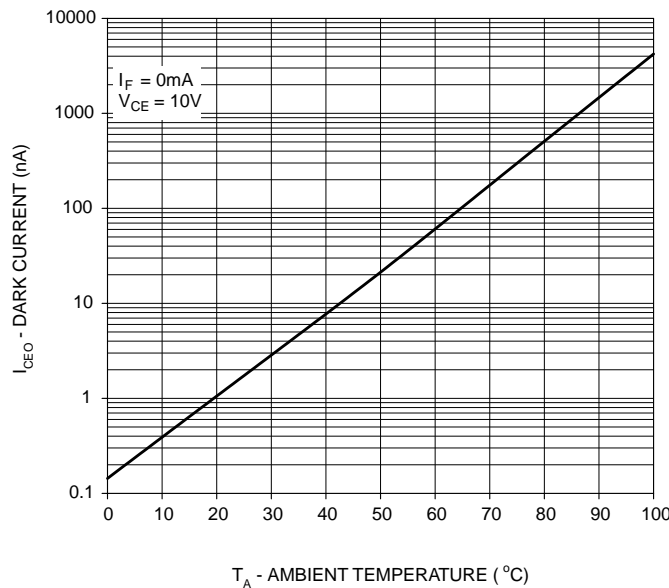

Figure 7. Collector-Emitter Dark Current vs. Ambient Temperature



H11AG1

H11AG2

H11AG3

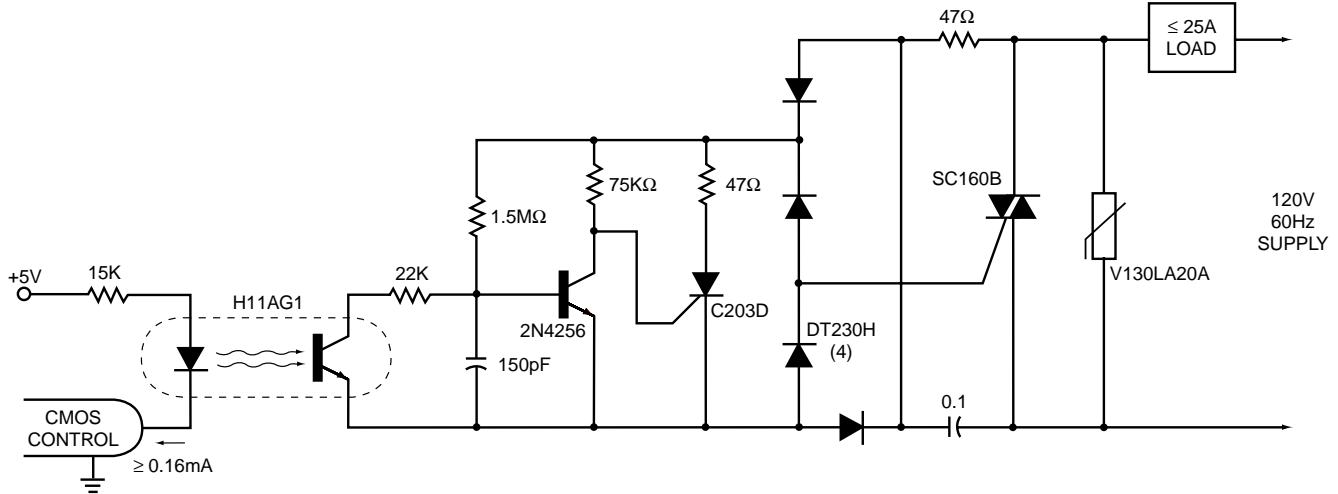
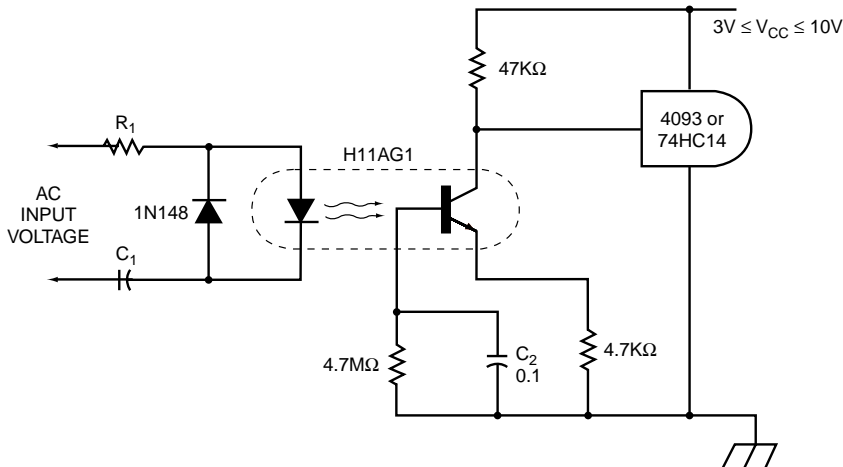

Figure 8. CMOS Input, 3KW, Zero Voltage Switching Solid State Relay

The H11AG1's superior performance at low input currents allows standard CMOS logic circuits to directly operate a 25A solid state relay. Circuit operation is as follows: power switching is provided by the SC160B, 25A triac. Its gate is controlled by the C203B via the DT230H rectifier bridge. The C203B turn-on is inhibited by the 2N4256 when line voltage is above 12V and/or the H11AG is off. False trigger and dv/dt protection are provided by the combination of the MOV® varistor and RC snubber network.



INPUT	R ₁	C ₁	Z
40-90 VRMS 20 Hz	75 K 1/10 W	0.1 μF 100 V	109K
95-135 VRMS 60 Hz	180 K 1/10 W	12 ηF 200 V	285K
200-280 VRMS 50/60 Hz	390 K 1/4 W	6.80 ηF 400 V	550K

DC component of input voltage is ignored due to C1

Figure 9. Telephone Ring Detector/A.C. Line CMOS Input Isolator

The H11AG1 uses less input power than the neon bulb traditionally used to monitor telephone and line voltages. Additionally, response time can be tailored to ignore telephone dial tap, switching transients and other undesired signals by modifying the value of C2. The high impedance to line voltage also can simply board layout spacing requirements.

H11AG1

H11AG2

H11AG3

Package Dimensions (Through Hole)

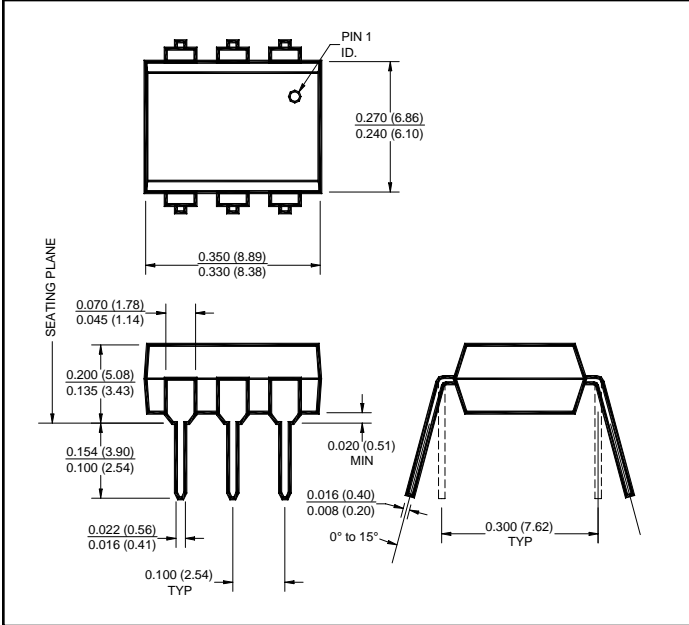

Package Dimensions (Surface Mount)

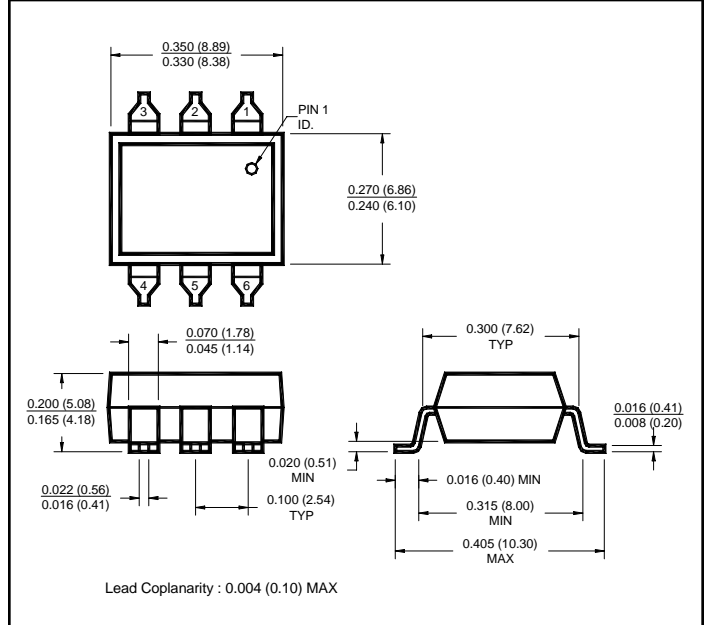

Package Dimensions (0.4" Lead Spacing)

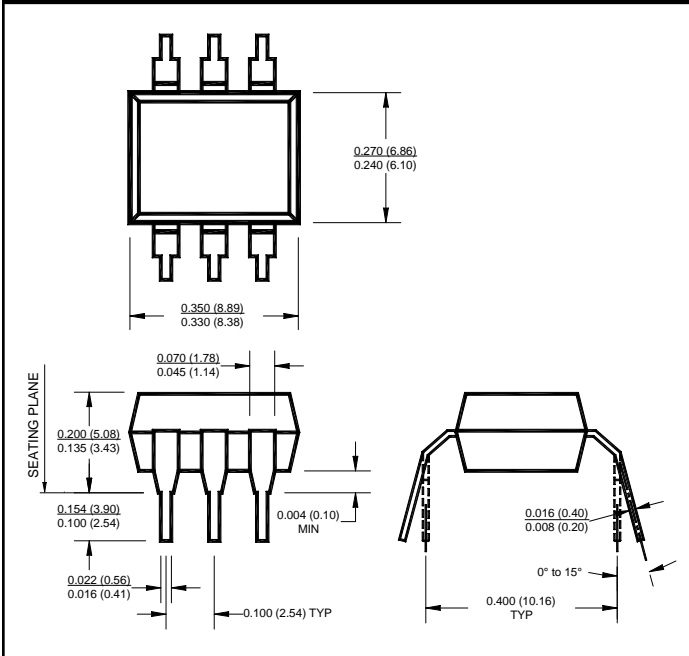

Recommended Pad Layout for Surface Mount Leadform

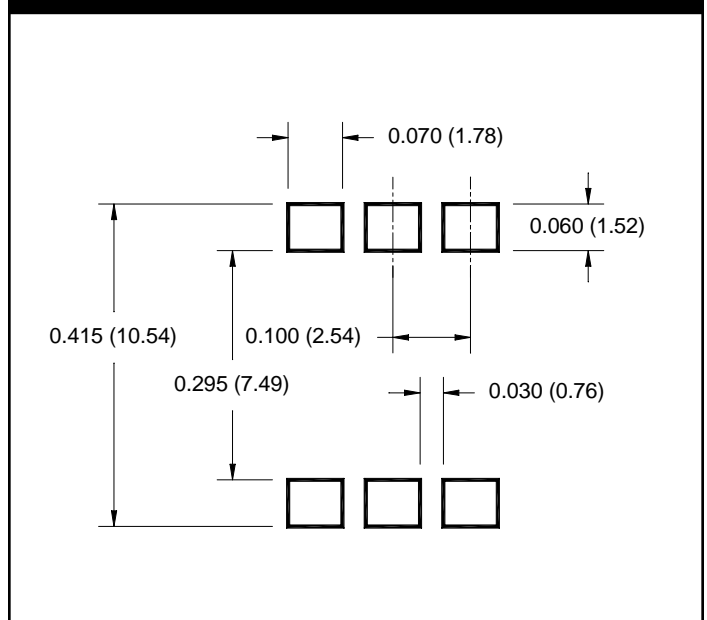

NOTE

All dimensions are in inches (millimeters)

H11AG1

H11AG2

H11AG3

Option	Order Entry Identifier	Description
S	.S	Surface Mount Lead Bend
SD	.SD	Surface Mount; Tape and reel
W	.W	0.4" Lead Spacing
300	.300	VDE 0884
300W	.300W	VDE 0884, 0.4" Lead Spacing
3S	.3S	VDE 0884, Surface Mount
3SD	.3SD	VDE 0884, Surface Mount, Tape & Reel

Carrier Tape Specifications ("D" Taping Orientation)

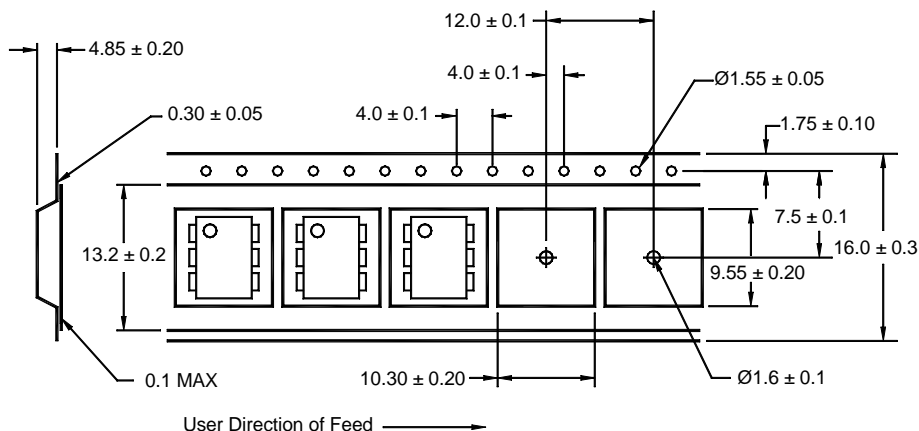

NOTE

All dimensions are millimeters

MARKING INFORMATION

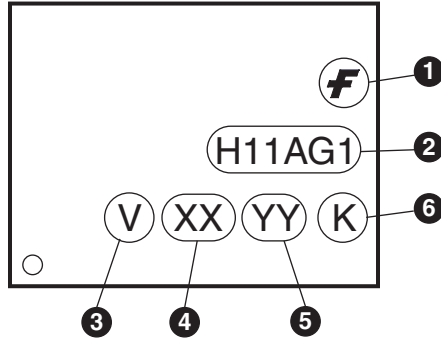

Definitions	
1	Fairchild logo
2	Device number
3	VDE mark (Note: Only appears on parts ordered with VDE option – See order entry table)
4	Two digit year code, e.g., '03'
5	Two digit work week ranging from '01' to '53'
6	Assembly package code

Reflow Profile (Black Package, No Suffix)

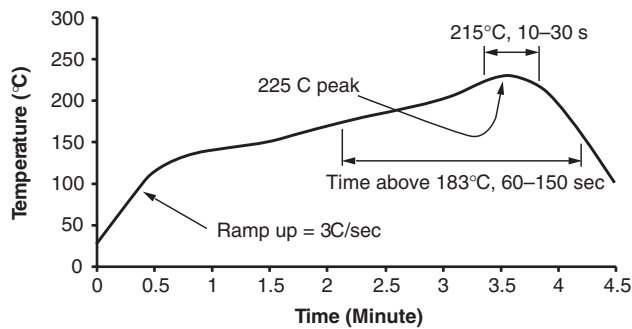

- Peak reflow temperature: 225°C (package surface temperature)
- Time of temperature higher than 183°C for 60–150 seconds
- One time soldering reflow is recommended

TRADEMARKS

The following are registered and unregistered trademarks Fairchild Semiconductor owns or is authorized to use and is not intended to be an exhaustive list of all such trademarks.

ACEx™	FAST®	ISOPLANAR™	Power247™	Stealth™
ActiveArray™	FASTr™	LittleFET™	PowerEdge™	SuperFET™
Bottomless™	FPST™	MICROCOUPLER™	PowerSaver™	SuperSOT™-3
CoolFET™	FRFET™	MicroFET™	PowerTrench®	SuperSOT™-6
CROSSVOLT™	GlobalOptoisolator™	MicroPak™	QFET®	SuperSOT™-8
DOMET™	GTO™	MICROWIRE™	QS™	SyncFET™
EcoSPARK™	HiSeC™	MSX™	QT Optoelectronics™	TinyLogic®
E ² CMOS™	μC™	MSXPro™	Quiet Series™	TINYOPTO™
EnSigna™	i-Lo™	OCX™	RapidConfigure™	TruTranslation™
FACT™	ImpliedDisconnect™	OCXPro™	RapidConnect™	UHC™
FACT Quiet Series™		OPTOLOGIC®	μSerDes™	UltraFET®
Across the board. Around the world.™		OPTOPLANAR™	SILENT SWITCHER®	VCX™
The Power Franchise®		PACMAN™	SMART START™	
Programmable Active Droop™		POP™	SPM™	

DISCLAIMER

FAIRCHILD SEMICONDUCTOR RESERVES THE RIGHT TO MAKE CHANGES WITHOUT FURTHER NOTICE TO ANY PRODUCTS HEREIN TO IMPROVE RELIABILITY, FUNCTION OR DESIGN. FAIRCHILD DOES NOT ASSUME ANY LIABILITY ARISING OUT OF THE APPLICATION OR USE OF ANY PRODUCT OR CIRCUIT DESCRIBED HEREIN; NEITHER DOES IT CONVEY ANY LICENSE UNDER ITS PATENT RIGHTS, NOR THE RIGHTS OF OTHERS.

LIFE SUPPORT POLICY

FAIRCHILD'S PRODUCTS ARE NOT AUTHORIZED FOR USE AS CRITICAL COMPONENTS IN LIFE SUPPORT DEVICES OR SYSTEMS WITHOUT THE EXPRESS WRITTEN APPROVAL OF FAIRCHILD SEMICONDUCTOR CORPORATION. As used herein:

1. Life support devices or systems are devices or systems which, (a) are intended for surgical implant into the body, or (b) support or sustain life, or (c) whose failure to perform when properly used in accordance with instructions for use provided in the labeling, can be reasonably expected to result in significant injury to the user.
2. A critical component is any component of a life support device or system whose failure to perform can be reasonably expected to cause the failure of the life support device or system, or to affect its safety or effectiveness.

PRODUCT STATUS DEFINITIONS

Definition of Terms

Datasheet Identification	Product Status	Definition
Advance Information	Formative or In Design	This datasheet contains the design specifications for product development. Specifications may change in any manner without notice.
Preliminary	First Production	This datasheet contains preliminary data, and supplementary data will be published at a later date. Fairchild Semiconductor reserves the right to make changes at any time without notice in order to improve design.
No Identification Needed	Full Production	This datasheet contains final specifications. Fairchild Semiconductor reserves the right to make changes at any time without notice in order to improve design.
Obsolete	Not In Production	This datasheet contains specifications on a product that has been discontinued by Fairchild semiconductor. The datasheet is printed for reference information only.



LittleDiode supplies new, hard to find or obsolete electronic components and semiconductors all over the world.

With over two million different components listed you are sure to find the part you need.

Feel free to visit us today at our online store:

LittleDiode.com

Looking forward to providing you with the best possible service.