

# DS1691A/DS3691 (RS-422/RS-423) Line Drivers with TRI-STATE® Outputs

## General Description

The DS1691A/DS3691 are low power Schottky TTL line drivers designed to meet the requirements of EIA standards RS-422 and RS-423. They feature 4 buffered outputs with high source and sink current capability with internal short circuit protection. A mode control input provides a choice of operation either as 4 single-ended line drivers or 2 differential line drivers. A rise time control pin allows the use of an external capacitor to slow the rise time for suppression of near end crosstalk to other receivers in the cable. Rise time capacitors are primarily intended for waveshaping output signals in the single-ended driver mode. Multipoint applications in differential mode with waveshaping capacitors is not allowed.

With the mode select pin low, the DS1691A/DS3691 are dual-differential line drivers with TRI-STATE outputs. They feature  $\pm 10V$  output common-mode range in TRI-STATE mode and 0V output unbalance when operated with  $\pm 5V$  supply.

## Features

- Dual RS-422 line driver with mode pin low, or quad RS-423 line driver with mode pin high
- TRI-STATE outputs in RS-422 mode
- Short circuit protection for both source and sink outputs
- Outputs will not clamp line with power off or in TRI-STATE
- 100 $\Omega$  transmission line drive capability
- Low  $I_{CC}$  and  $I_{EE}$  power consumption
  - RS-422:  $I_{CC} = 9$  mA/driver typ
  - RS-423:  $I_{CC} = 4.5$  mA/driver typ;  
 $I_{EE} = 2.5$  mA/driver typ
- Low current PNP inputs compatible with TTL, MOS and CMOS
- Pin compatible with AM26LS30

## Connection Diagrams

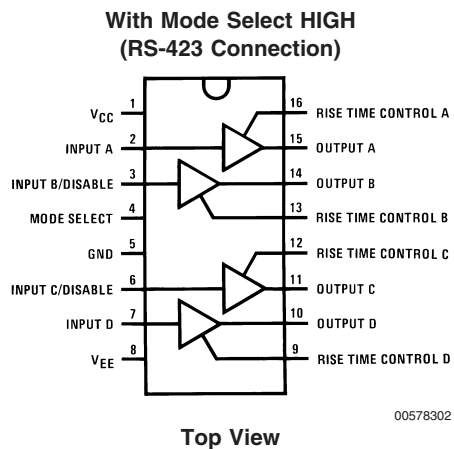
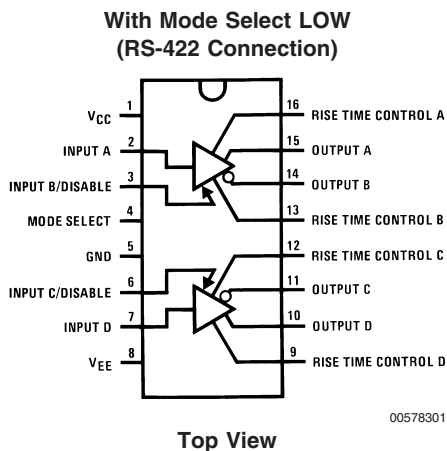

## Ordering Information

Order Number	Package Type	NS Package Number
DS3691M	SO Package	M16A
DS3691N	Molded DIP	N16E
For Complete Military Product Specifications, refer to the appropriate SMD or MDS.		
DS1691AJ/883	Ceramic DIP	J16A

TRI-STATE® is a registered trademark of National Semiconductor Corporation.

**Absolute Maximum Ratings** (Note 2)

If Military/Aerospace specified devices are required, please contact the National Semiconductor Sales Office/Distributors for availability and specifications.

Supply Voltage	
$V_{CC}$	7V
$V_{EE}$	-7V
Maximum Power Dissipation (Note 1) at 25°C	
Cavity Package	1509 mW
Molded DIP Package	1476 mW
SO Package	1051 mW
Input Voltage	15V
Output Voltage (Power OFF)	±15V
Storage Temperature	-65°C to +150°C
Lead Temperature (Soldering, 4 seconds)	260°C

**Operating Conditions**

	Min	Max	Units
Supply Voltage			
DS1691A			
$V_{CC}$	4.5	5.5	V
$V_{EE}$	-4.5	-5.5	V
DS3691			
$V_{CC}$	4.75	5.25	V
$V_{EE}$	-4.75	-5.25	V
Temperature ( $T_A$ )			
DS1691A	-55	+125	°C
DS3691	0	+70	°C

**Note 1:** Derate cavity package 10.1 mW/°C above 25°C; derate molded DIP package 11.9 mW/°C above 25°C. Derate SO package 8.41 mW/°C above 25°C.

**DC Electrical Characteristics** (Notes 3, 4, 5, 6)

Symbol	Parameter	Conditions	Min	Typ	Max	Units	
<b>RS-422 CONNECTION, <math>V_{EE}</math> CONNECTION TO GROUND, MODE SELECT ≤ 0.8V</b>							
$V_{IH}$	High Level Input Voltage		2			V	
$V_{IL}$	Low Level Input Voltage				0.8	V	
$I_{IH}$	High Level Input Current	$V_{IN} = 2.4V$		1	40	μA	
		$V_{IN} \leq 15V$		10	100	μA	
$I_{IL}$	Low Level Input Current	$V_{IN} = 0.4V$		-30	-200	μA	
$V_I$	Input Clamp Voltage	$I_{IN} = -12\text{ mA}$			-1.5	V	
$V_O$ $\overline{V_O}$	Differential Output Voltage $V_{A,B}$	$R_L = \infty$	$V_{IN} = 2V$		3.6	6.0	V
			$V_{IN} = 0.8V$		-3.6	-6.0	V
$V_T$ $\overline{V_T}$	Differential Output Voltage $V_{A,B}$	$R_L = 100\Omega$ $V_{CC} \geq 4.75V$	$V_{IN} = 2V$	2	2.4		V
			$V_{IN} = 0.8V$	-2	-2.4		V
$V_{OS}, \overline{V_{OS}}$	Common-Mode Offset Voltage	$R_L = 100\Omega$		2.5	3	V	
$ V_T  -  \overline{V_T} $	Difference in Differential Output Voltage	$R_L = 100\Omega$		0.05	0.4	V	
$ V_{OS}  -  \overline{V_{OS}} $	Difference in Common-Mode Offset Voltage	$R_L = 100\Omega$		0.05	0.4	V	
$V_{SS}$	$ V_T - \overline{V_T} $	$R_L = 100\Omega, V_{CC} \geq 4.75V$	4.0	4.8		V	
$V_{CMR}$	Output Voltage Common-Mode Range	$V_{DISABLE} = 2.4V$	±10			V	
$I_{XA}$	Output Leakage Current Power OFF	$V_{CC} = 0V$	$V_{CMR} = 10V$		100	μA	
$I_{XB}$			$V_{CMR} = -10V$		-100	μA	
$I_{OX}$	TRI-STATE Output Current	$V_{CC} = \text{Max}$ $V_{EE} = 0V \text{ and } -5V$	$V_{CMR} \leq 10V$		100	μA	
			$V_{CMR} \geq -10V$		-100	μA	
$I_{SA}$	Output Short Circuit Current	$V_{IN} = 0.4V$	$V_{OA} = 6V$		80	150	mA
			$V_{OB} = 0V$		-80	-150	mA
$I_{SB}$	Output Short Circuit Current	$V_{IN} = 2.4V$	$V_{OA} = 0V$		-80	-150	mA
			$V_{OB} = 6V$		80	150	mA
$I_{CC}$	Supply Current			18	30	mA	

**AC Electrical Characteristics** (Note 6) $T_A = 25^\circ\text{C}$ 

Symbol	Parameter	Conditions	Min	Typ	Max	Units
<b>RS-422 CONNECTION, <math>V_{CC} = 5\text{V}</math>, MODE SELECT = 0.8V</b>						
$t_r$	Output Rise Time	$R_L = 100\Omega$ , $C_L = 500\text{ pF}$ (Figure 1)		120	200	ns
$t_f$	Output Fall Time	$R_L = 100\Omega$ , $C_L = 500\text{ pF}$ (Figure 1)		120	200	ns
$t_{PDH}$	Output Propagation Delay	$R_L = 100\Omega$ , $C_L = 500\text{ pF}$ (Figure 1)		120	200	ns
$t_{PDL}$	Output Propagation Delay	$R_L = 100\Omega$ , $C_L = 500\text{ pF}$ (Figure 1)		120	200	ns
$t_{PZL}$	TRI-STATE Delay	$R_L = 450\Omega$ , $C_L = 500\text{ pF}$ , $C_C = 0\text{ pF}$ (Figure 4)		250	350	ns
$t_{PZH}$	TRI-STATE Delay	$R_L = 450\Omega$ , $C_L = 500\text{ pF}$ , $C_C = 0\text{ pF}$ (Figure 4)		180	300	ns
$t_{PLZ}$	TRI-STATE Delay	$R_L = 450\Omega$ , $C_L = 500\text{ pF}$ , $C_C = 0\text{ pF}$ (Figure 4)		180	300	ns
$t_{PHZ}$	TRI-STATE Delay	$R_L = 450\Omega$ , $C_L = 500\text{ pF}$ , $C_C = 0\text{ pF}$ (Figure 4)		250	350	ns

**DC Electrical Characteristics** (Notes 3, 4, 5, 6)

Symbol	Parameter	Conditions	Min	Typ	Max	Units	
<b>RS-423 CONNECTION, <math> V_{CC}  =  V_{EE} </math>, MODE SELECT <math>\geq 2\text{V}</math></b>							
$V_{IH}$	High Level Input Voltage		2			V	
$V_{IL}$	Low Level Input Voltage				0.8	V	
$I_{IH}$	High Level Input Current	$V_{IN} = 2.4\text{V}$		1	40	$\mu\text{A}$	
		$V_{IN} \leq 15\text{V}$		10	100	$\mu\text{A}$	
$I_{IL}$	Low Level Input Current	$V_{IN} = 0.4\text{V}$		-30	-200	$\mu\text{A}$	
$V_I$	Input Clamp Voltage	$I_{IN} = -12\text{ mA}$			-1.5	V	
$V_O$	Output Voltage	$R_L = \infty$ , (Note 7) $V_{CC} \geq 4.75\text{V}$	$V_{IN} = 2\text{V}$	4.0	4.4	6.0	V
$\overline{V}_O$			$V_{IN} = 0.4\text{V}$	-4.0	-4.4	-6.0	V
$V_T$	Output Voltage	$R_L = 450\Omega$ $V_{CC} \geq 4.75\text{V}$	$V_{IN} = 2.4\text{V}$	3.6	4.1		V
$\overline{V}_T$			$V_{IN} = 0.4\text{V}$	-3.6	-4.1		V
$ V_T  -  \overline{V}_T $	Output Unbalance	$ V_{CC}  =  V_{EE}  = 4.75\text{V}$ , $R_L = 450\Omega$		0.02	0.4	V	
$I_{X^+}$	Output Leakage Power OFF	$V_{CC} = V_{EE} = 0\text{V}$	$V_O = 6\text{V}$	2	100	$\mu\text{A}$	
$I_{X^-}$	Output Leakage Power OFF	$V_{CC} = V_{EE} = 0\text{V}$	$V_O = -6\text{V}$	-2	-100	$\mu\text{A}$	
$I_{S^+}$	Output Short Circuit Current	$V_O = 0\text{V}$	$V_{IN} = 2.4\text{V}$	-80	-150	mA	
$I_{S^-}$	Output Short Circuit Current	$V_O = 0\text{V}$	$V_{IN} = 0.4\text{V}$	80	150	mA	
$I_{SLEW}$	Slew Control Current			$\pm 140$		$\mu\text{A}$	
$I_{CC}$	Positive Supply Current	$V_{IN} = 0.4\text{V}$ , $R_L = \infty$		18	30	mA	
$I_{EE}$	Negative Supply Current	$V_{IN} = 0.4\text{V}$ , $R_L = \infty$		-10	-22	mA	

**Note 2:** "Absolute Maximum Ratings" are those values beyond which the safety of the device cannot be guaranteed. They are not meant to imply that the devices should be operated at these limits. The tables of "Electrical Characteristics" provide conditions for actual device operation.

**Note 3:** Unless otherwise specified, min/max limits apply across the  $-55^\circ\text{C}$  to  $+125^\circ\text{C}$  temperature range for the DS1691A and across the  $0^\circ\text{C}$  to  $+70^\circ\text{C}$  range for the DS3691. All typicals are given for  $V_{CC} = 5\text{V}$  and  $T_A = 25^\circ\text{C}$ .  $V_{CC}$  and  $V_{EE}$  as listed in operating conditions.

**Note 4:** All currents into device pins are positive; all currents out of device pins are negative. All voltages are referenced to ground unless otherwise specified.

**Note 5:** Only one output at a time should be shorted.

**Note 6:** Symbols and definitions correspond to EIA RS-422 and/or RS-423 where applicable.

**Note 7:** At  $-55^\circ\text{C}$ , the output voltage is  $+3.9\text{V}$  minimum and  $-3.9\text{V}$  minimum.

**AC Electrical Characteristics** (Note 6) $T_A = 25^\circ\text{C}$ 

Symbol	Parameter	Conditions	Min	Typ	Max	Units
<b>RS-423 CONNECTION, <math>V_{CC} = 5\text{V}</math>, <math>V_{EE} = -5\text{V}</math>, MODE SELECT = 2.4V</b>						
$t_r$	Rise Time	$R_L = 450\Omega$ , $C_L = 500\text{ pF}$ , $C_C = 0$ (Figure 2)		120	300	ns
$t_f$	Fall Time	$R_L = 450\Omega$ , $C_L = 500\text{ pF}$ , $C_C = 0$ (Figure 2)		120	300	ns
$t_r$	Rise Time	$R_L = 450\Omega$ , $C_L = 500\text{ pF}$ , $C_C = 50\text{ pF}$ (Figure 3)		3.0		$\mu\text{s}$
$t_f$	Fall Time	$R_L = 450\Omega$ , $C_L = 500\text{ pF}$ , $C_C = 50\text{ pF}$ (Figure 3)		3.0		$\mu\text{s}$
$t_{rc}$	Rise Time Coefficient	$R_L = 450\Omega$ , $C_L = 500\text{ pF}$ , $C_C = 50\text{ pF}$ (Figure 3)		0.06		$\mu\text{s/pF}$

# AC Electrical Characteristics (Note 6) (Continued)

$T_A = 25^\circ\text{C}$

Symbol	Parameter	Conditions	Min	Typ	Max	Units
$t_{PDH}$	Output Propagation Delay	$R_L = 450\Omega, C_L = 500\text{ pF}, C_C = 0$ (Figure 2)		180	300	ns
$t_{PDL}$	Output Propagation Delay	$R_L = 450\Omega, C_L = 500\text{ pF}, C_C = 0$ (Figure 2)		180	300	ns

## AC Test Circuits and Switching Time Waveforms

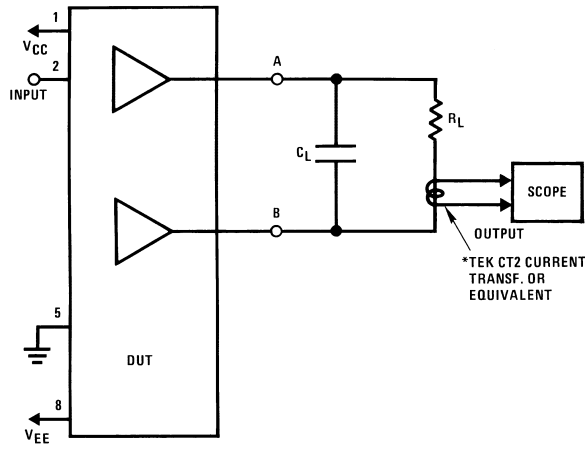

00578303

FIGURE 1. Differential Connection

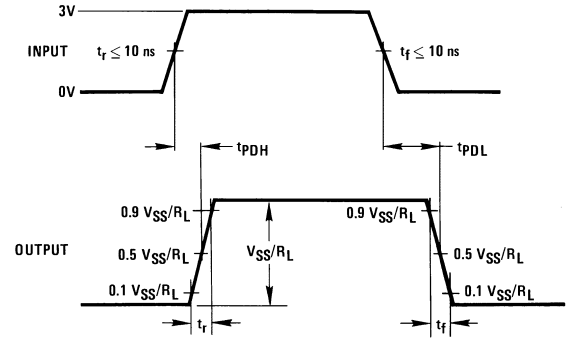

00578304

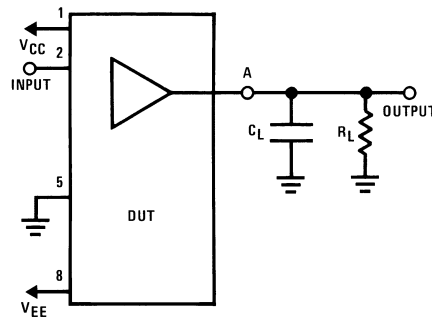

00578305

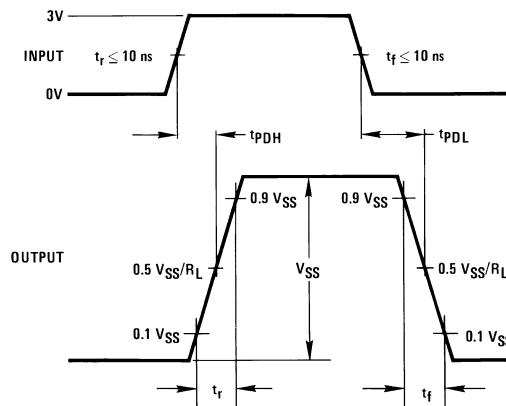

00578306

FIGURE 2. RS-423 Connection

AC Test Circuits and Switching Time Waveforms (Continued)

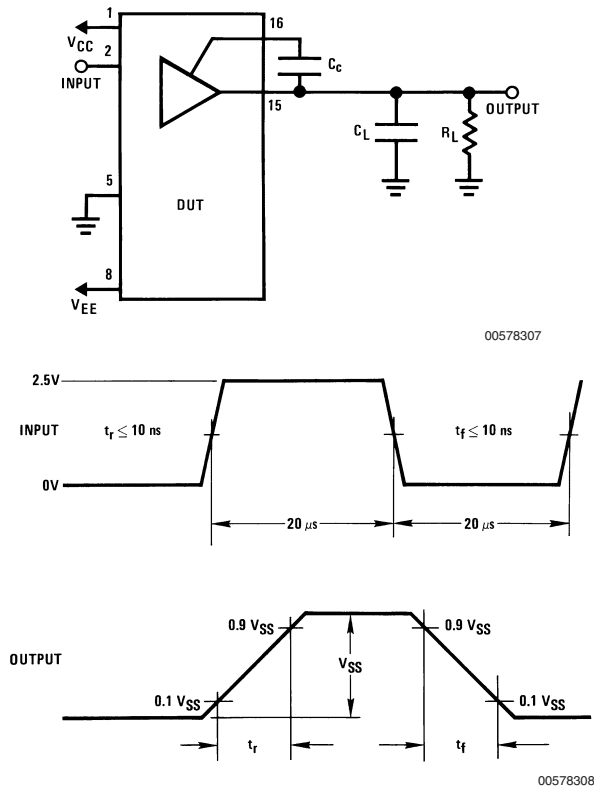

FIGURE 3. Rise Time Control for RS-423

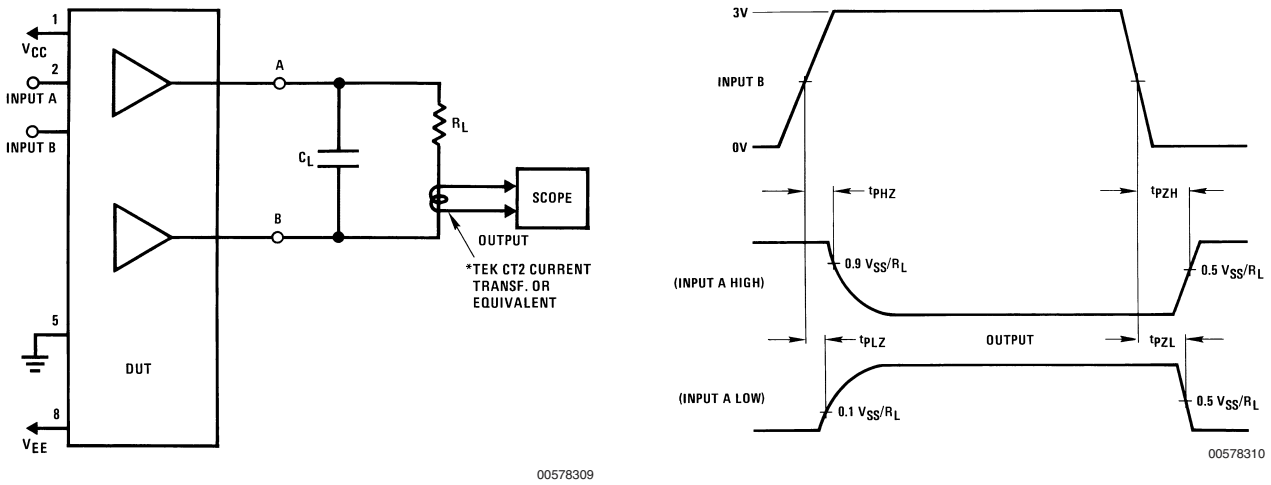

FIGURE 4. TRI-STATE Delays

## Switching Waveforms

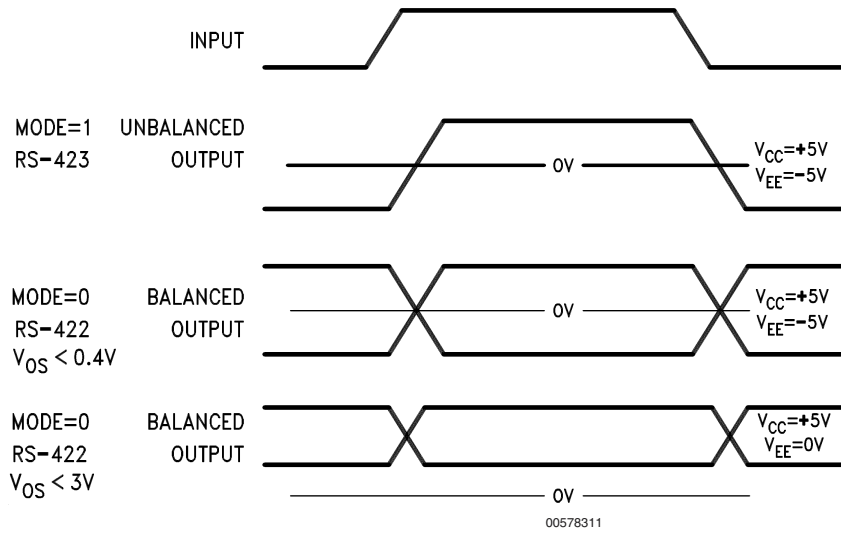
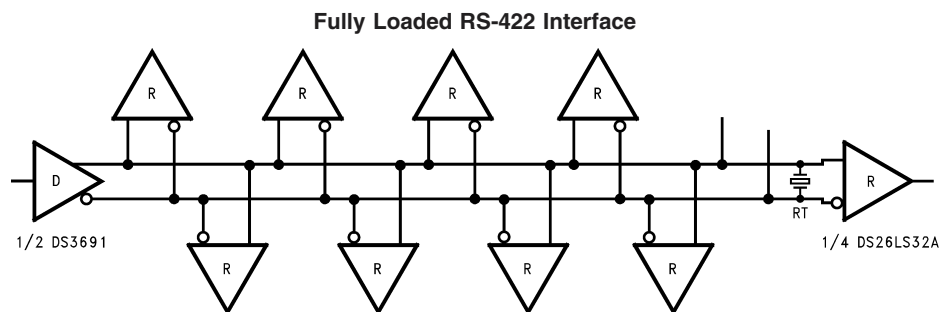

FIGURE 5. Typical Output Voltage

## Truth Table

Operation	Inputs			Outputs	
	Mode	A (D)	B (C)	A (D)	B (C)
RS-422	0	0	0	0	1
	0	0	1	TRI-STATE	TRI-STATE
	0	1	0	1	0
	0	1	1	TRI-STATE	TRI-STATE
RS-423	1	0	0	0	0
	1	0	1	0	1
	1	1	0	1	0
	1	1	1	1	1

## Typical Application Information



00578313

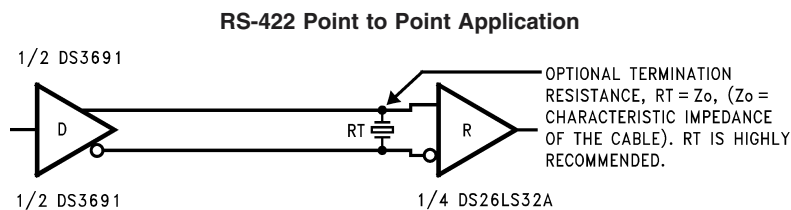

00578314

Typical Application Information (Continued)

Fully Loaded RS-423 Interface

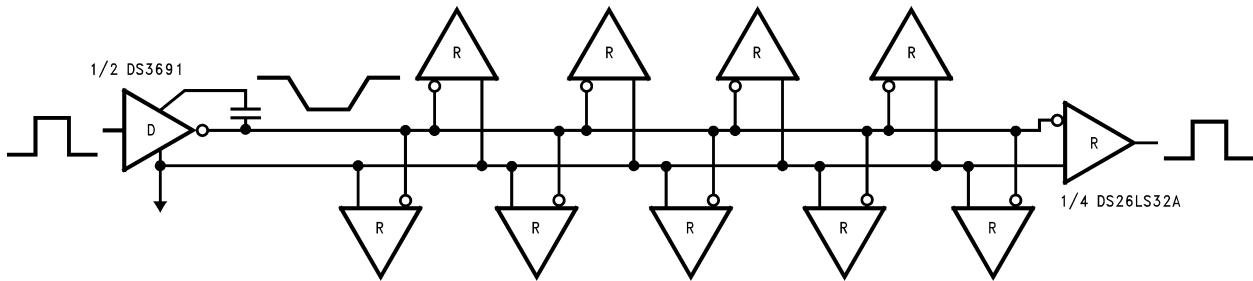

00578315

Differential Application with Rise Time Control

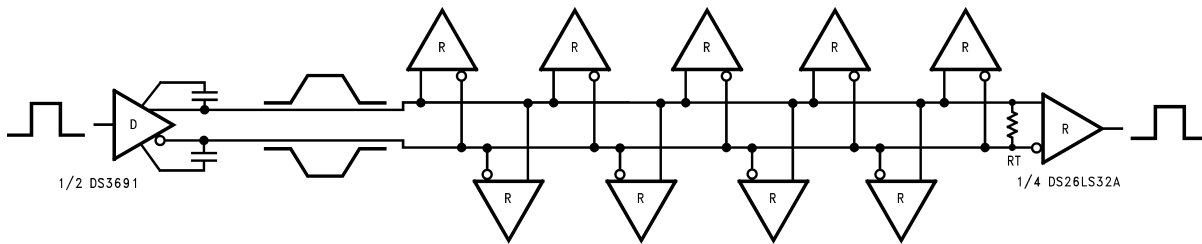

00578316

\*Note: Controlled edge allows longer stub lengths. Multiple Drivers are NOT allowed.

Dual RS-423 Inverting Driver

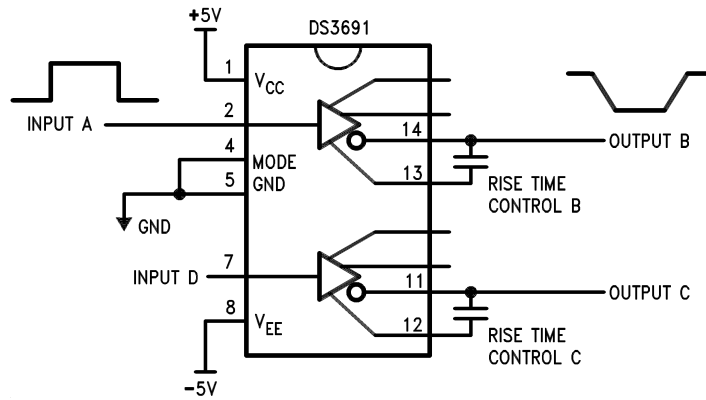

00578317

# Typical Rise Time Control Characteristics (RS-423 Mode)

Rise Time vs External Capacitor

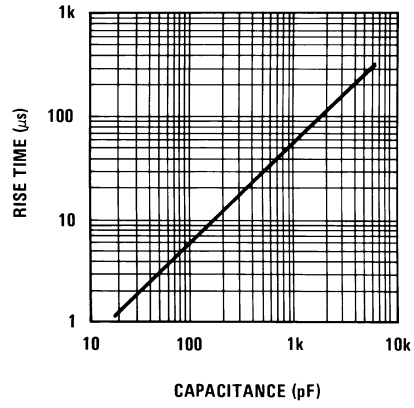

00578312

**Physical Dimensions** inches (millimeters)

unless otherwise noted

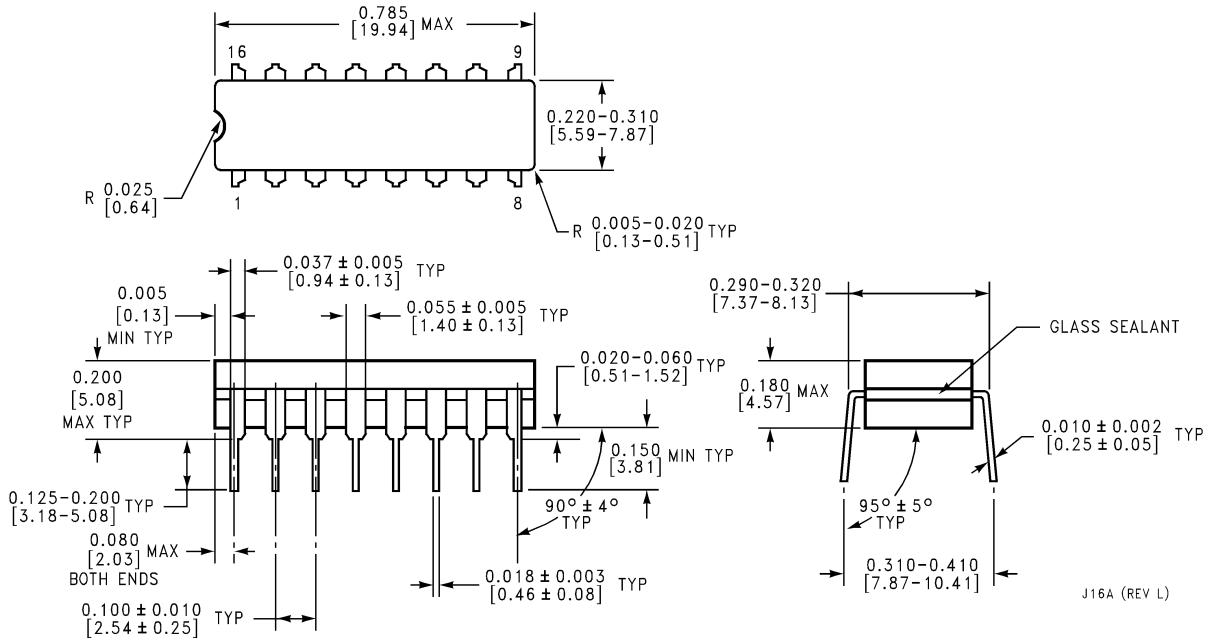

**Ceramic Dual-In-Line Package (J)**  
**Order Number DS1691AJ/883**  
**NS Package Number J16A**

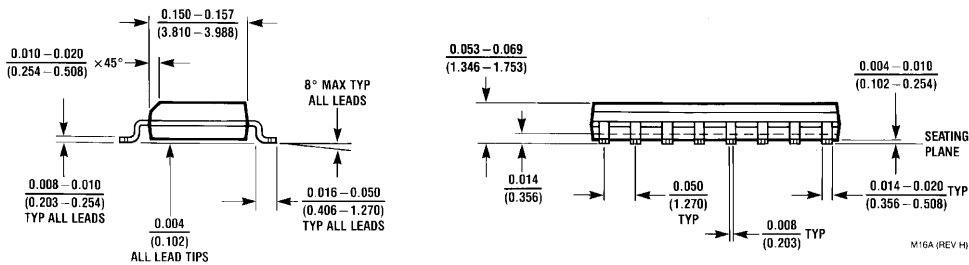
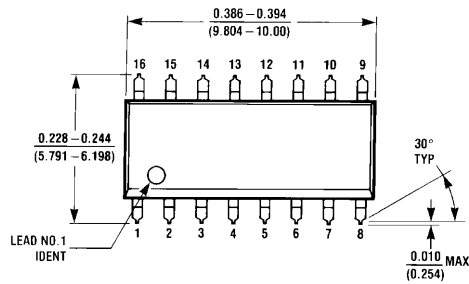

**SO Package (M)**  
**Order Number DS3691M**  
**NS Package Number M16A**

**Physical Dimensions** inches (millimeters) unless otherwise noted (Continued)

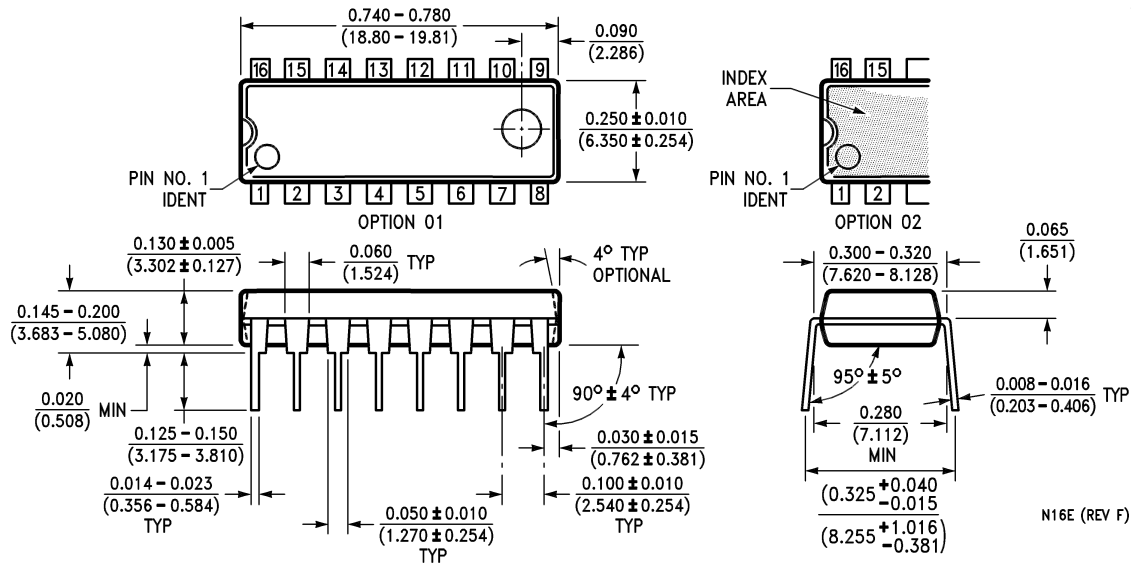

**Molded Dual-In-Line Package (N)**  
**Order Number DS3691N**  
**NS Package Number N16E**

**LIFE SUPPORT POLICY**

NATIONAL'S PRODUCTS ARE NOT AUTHORIZED FOR USE AS CRITICAL COMPONENTS IN LIFE SUPPORT DEVICES OR SYSTEMS WITHOUT THE EXPRESS WRITTEN APPROVAL OF THE PRESIDENT AND GENERAL COUNSEL OF NATIONAL SEMICONDUCTOR CORPORATION. As used herein:

1. Life support devices or systems are devices or systems which, (a) are intended for surgical implant into the body, or (b) support or sustain life, and whose failure to perform when properly used in accordance with instructions for use provided in the labeling, can be reasonably expected to result in a significant injury to the user.
2. A critical component is any component of a life support device or system whose failure to perform can be reasonably expected to cause the failure of the life support device or system, or to affect its safety or effectiveness.

**BANNED SUBSTANCE COMPLIANCE**

National Semiconductor certifies that the products and packing materials meet the provisions of the Customer Products Stewardship Specification (CSP-9-111C2) and the Banned Substances and Materials of Interest Specification (CSP-9-111S2) and contain no "Banned Substances" as defined in CSP-9-111S2.

 <p><b>National Semiconductor</b>  Americas Customer Support Center  Email: new.feedback@nsc.com  Tel: 1-800-272-9959</p>	<p><b>National Semiconductor</b>  Europe Customer Support Center  Fax: +49 (0) 180-530 85 86  Email: europe.support@nsc.com  Deutsch Tel: +49 (0) 69 9508 6208  English Tel: +44 (0) 870 24 0 2171  Français Tel: +33 (0) 1 41 91 8790</p>	<p><b>National Semiconductor</b>  Asia Pacific Customer Support Center  Email: ap.support@nsc.com</p>	<p><b>National Semiconductor</b>  Japan Customer Support Center  Fax: 81-3-5639-7507  Email: jpn.feedback@nsc.com  Tel: 81-3-5639-7560</p>
--	--	---	--

# National Semiconductor was acquired by Texas Instruments.

[http://www.ti.com/corp/docs/investor\\_relations/pr\\_09\\_23\\_2011\\_national\\_semiconductor.html](http://www.ti.com/corp/docs/investor_relations/pr_09_23_2011_national_semiconductor.html)

This file is the datasheet for the following electronic components:

DS1691AJ/883 - <http://www.ti.com/product/ds1691aj/883?HQS=TI-null-null-dscatalog-df-pf-null-wwe>

DS3691MX - <http://www.ti.com/product/ds3691mx?HQS=TI-null-null-dscatalog-df-pf-null-wwe>

DS3691N - <http://www.ti.com/product/ds3691n?HQS=TI-null-null-dscatalog-df-pf-null-wwe>

5962-8672101EA - <http://www.ti.com/product/5962-8672101ea?HQS=TI-null-null-dscatalog-df-pf-null-wwe>

DS3691M - <http://www.ti.com/product/ds3691m?HQS=TI-null-null-dscatalog-df-pf-null-wwe>



LittleDiode supplies new, hard to find or obsolete electronic components and semiconductors all over the world.

With over two million different components listed you are sure to find the part you need.

Feel free to visit us today at our online store:

[LittleDiode.com](http://LittleDiode.com)

Looking forward to providing you with the best possible service.