



H1563P / H1563S

HIGH-EFFICIENCY DC/DC CONVERTER

Description

The H1563 is a monolithic control circuit containing the primary functions required for DC to DC converters and highside-sensed constant current source. The device consists of an internal temperature compensated reference, comparator, controlled duty cycle oscillator with an active current sense circuit, bootstrapped driver, and high current output switch. This device is specifically designed to construct a constant current source for battery chargers with a minimum number of external components. Bootstrapped driver can drive the NPN output switch to saturation for higher efficiency and less heat dissipation. The H1563 can deliver 1.5A continuous current without requiring a heat sink.

Features

- 3V to 40V Input Voltage Operation
- Internal 2A Peak Current Switch
- 1.5A Continuous Output Current
- Bootstrapped Driver
- High Side Current Sense Capability
- High Efficiency (up to 90%)
- Internal $\pm 2\%$ Reference
- Low Quiescent Current at 1.6mA
- Frequency Operation from 100Hz to 100KHz

Applications

- Constant Current Source for Battery Chargers
- Saver for Cellular Phone
- Step-Down DC-DC Converter Module

Typical Application Circuit

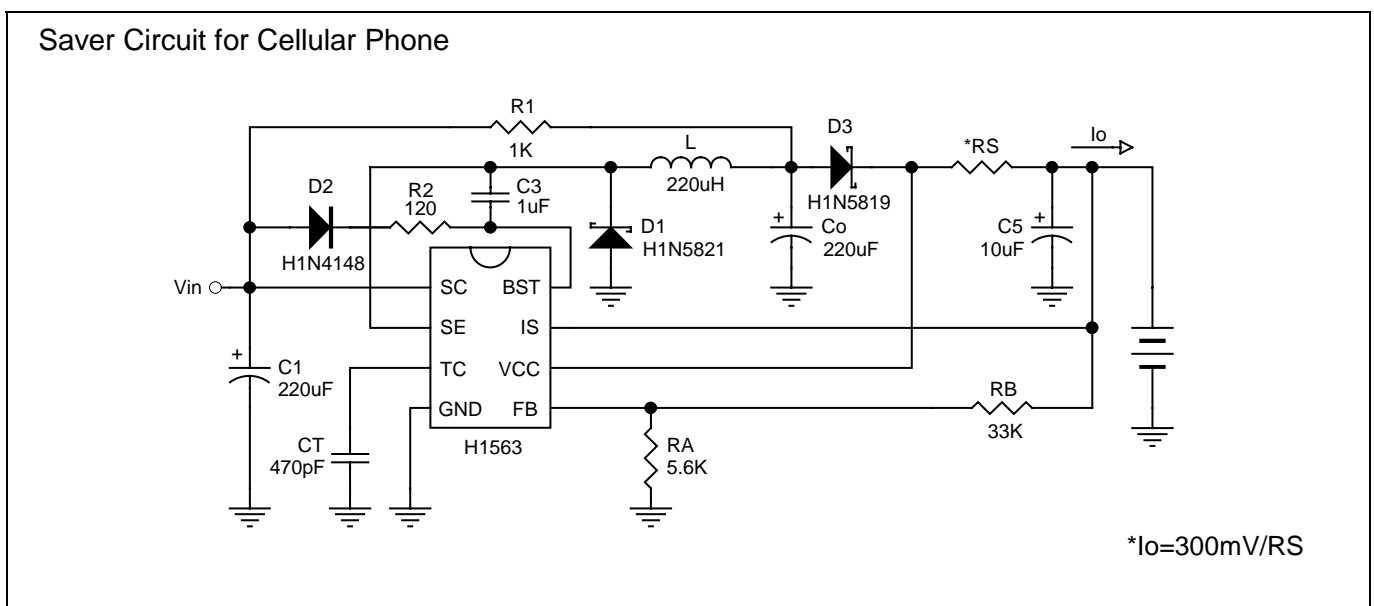



Pin Connections

Order No.		Pin1: SC-2A Switch Collector	Pin5: FB-Feedback Comparator Inverting Input
H1563P (Plastic DIP)		Pin2: SE-Darlington Switch Emitter	Pin6: VCC-Power Supply Input
H1563S (Plastic SO)		Pin3: TC-Oscillator Timing Capacitor	Pin7: IS-Highside Current Sense Input
		Pin4: GND-Power Ground	Pin8: BST-Bootstrapped Driver Collector

Block Diagram

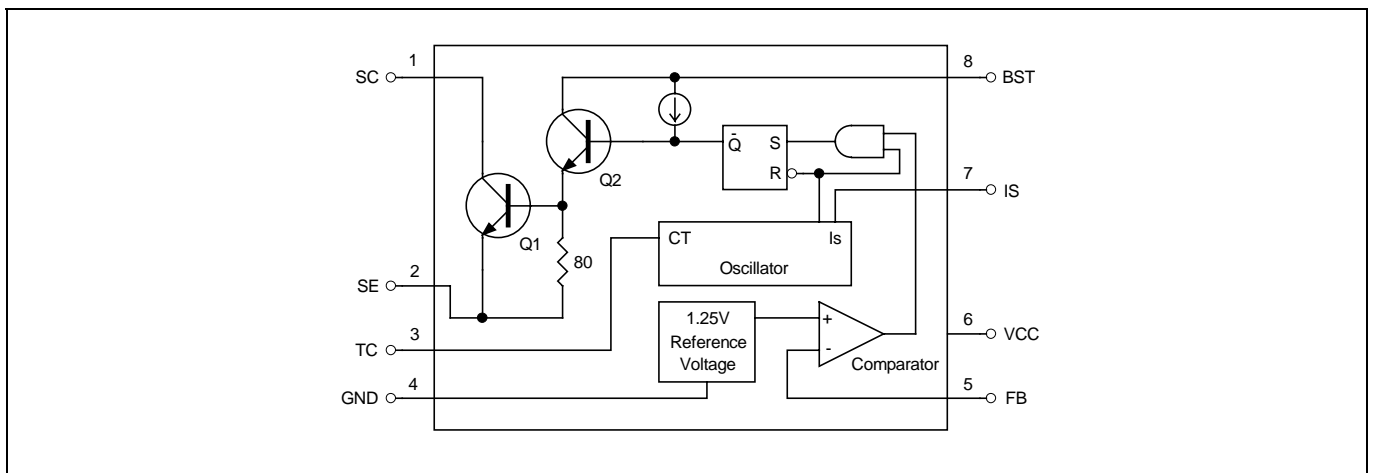

Absolute Maximum Rating

Rating	Symbol	Value	Unit
Power Supply Voltage	Vcc	40	Vdc
Comparator Input Voltage Range	Vir	0.3 ~ +40	Vdc
Switch Collector Voltage	Vc(switch)	40	Vdc
Switch Emitter Voltage (Vpin1=40V)	Ve(switch)	40	Vdc
Switch Collector to Emitter Voltage	Vce(switch)	40	Vdc
Driver Collector Voltage	Vc(driver)	40	Vdc
Switch Current	Isw	2	A
Operating Junction Temperature	Tj	150	°C
Operating Ambient Temperature Range	Ta	0 to +70	°C
Storage Temperature Range	Tstg	-65 to +150	°C
DIP Package Power Dissipation and Thermal Characteristics:			
Ta=25°C		1.5	W
Thermal Resistance		85	°C/W
SO Package Power Dissipation and Thermal Characteristics:			
Ta=25°C		1.2	W
Thermal Resistance		105	°C/W



Test Circuit

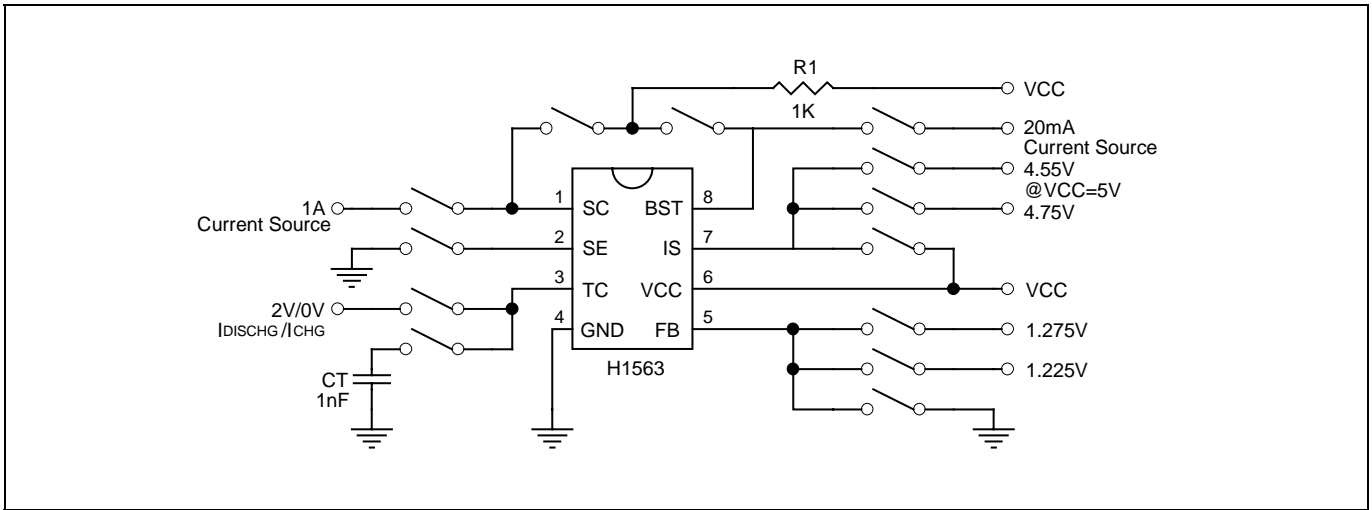

Characteristics Curve

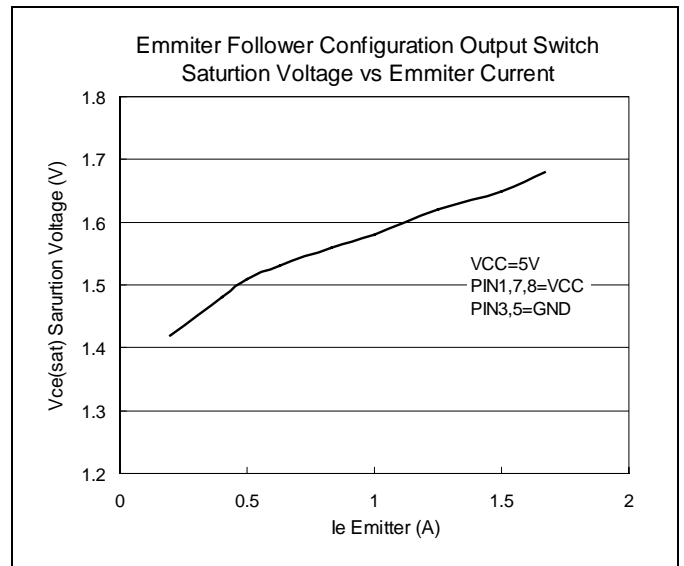
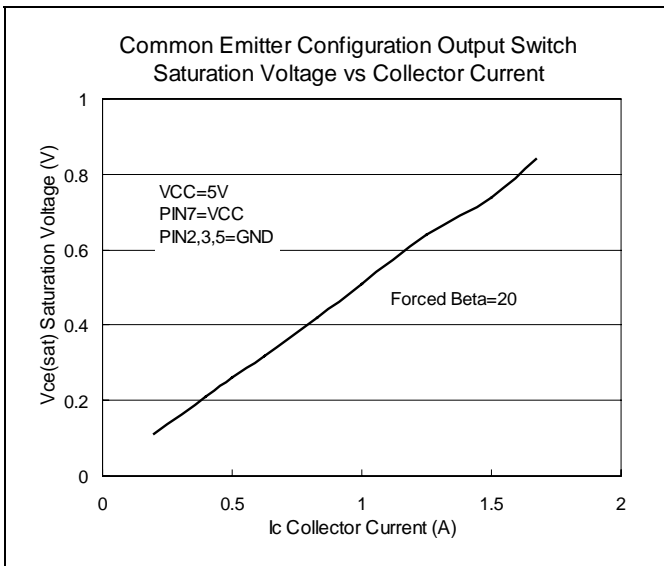
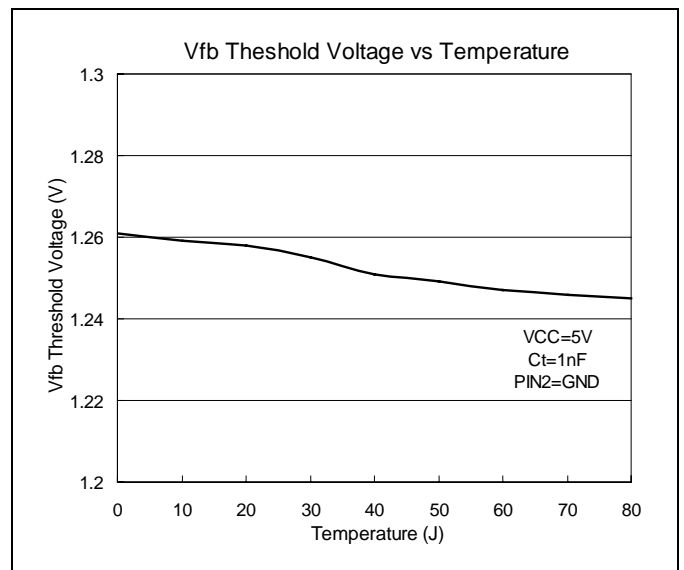
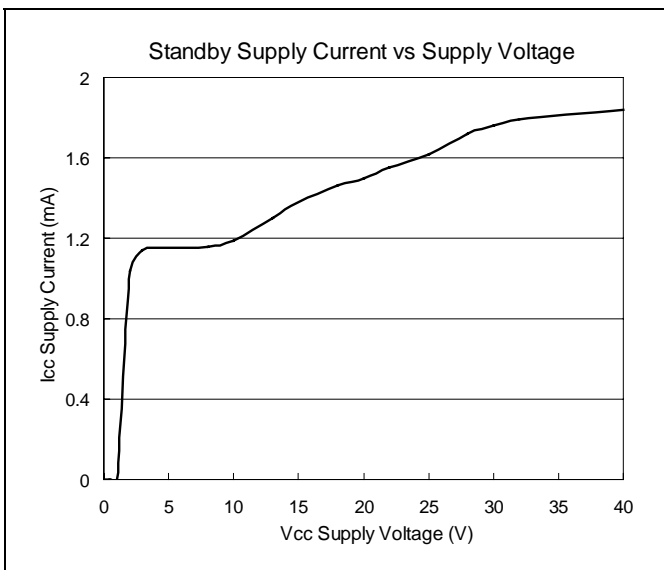



Electrical Characteristics (V_{CC}=5V, T_a=25°C, unless otherwise specified)

Parameter	Test Condition	Symbol	Min.	Typ.	Max.	Unit
<i>Oscillator</i>						
Charging Current	5V ≤ V _{CC} ≤ 40V	I _{chg}	24	35	42	uA
Discharge Current	5V ≤ V _{CC} ≤ 40V	I _{dischg}	140	220	260	uA
Voltage Swing	Pin3	V _{Osc}	-	0.6	-	V
Discharge to Charge Current Ratio	V _{IS} = V _{CC}	I _{Dischg} /I _{chg}	-	6	-	
Current Limit Sense Voltage	I _{Chg} =I _{dischg}	V _{CC} -V _{IS}	250	300	350	mV
<i>Output Switch</i>						
Saturation Voltage, Emitter Follower Connection	I _{SE} =1A, V _{BST} =V _{SC} =V _{CC}	V _{CE} (Sat)	-	1	1.3	V
Saturation Voltage	I _{SC} =1A, I _{BST} =50mA (Forced β ≈ 20)	V _{CE} (Sat)	-	0.4	0.7	V
DC Current Gain	I _{SC} =1A, V _{CE} =5V	h _{FE}	35	120	-	
Collector Off-State Current	V _{CE} =30V	I _{CC} (Off)	-	10	-	nA
<i>Comparator</i>						
Threshold Voltage	T _a =25°C	V _{FB}	1.227	1.25	1.273	V
	0°C ≤ T _a ≤ 70°C		1.21	-	1.29	V
Threshold Voltage Line Regulation	3V ≤ V _{CC} ≤ 40V	REG _{Line}	-	3	6	mV
Input Bias Current	V _{IN} =0V	I _{IB}	-	20	400	nA
Supply Current	V _{IS} =V _{CC} , V _{Pin5} >V _{FB} 5V ≤ V _{CC} ≤ 40V, C _T =1nF Pin2=Gnd Remaining pins open	I _{CC}	-	1.6	3	mA

Application Information

Design Formula Table

Calculation	Step-Down	Step-Up
ton / toff	$V_{out} + V_F / (V_{in(min)} - V_{sat} - V_{out})$	$V_{out} + V_F - V_{in(min)} / (V_{in(min)} - V_{sat})$
(ton+toff) max	1 / F _{min}	1 / F _{min}
C _T	4*10 ⁻⁵ ton	4*10 ⁻⁵ ton
I _C (switch)	2*I _{out} (max)	2*I _{out} (max)*(ton+toff / toff)
R _S	0.3 / I _C (switch)	0.3 / I _C (switch)
L(min)	$((V_{in(min)} - V_{sat} - V_{out}) / I_{C}(switch)) * ton(max)$	$((V_{in(min)} - V_{sat}) / I_{C}(switch)) * ton(max)$
C _O	$I_{C}(switch) * (ton+toff) / 8V_{Ripple(P-P)}$	$I_{out} * ton / V_{Ripple(P-P)}$

V_{sat}: Saturation voltage of the output switch.

V_F: Forward voltage of the ringback rectifier.

The following power supply characteristics must be chosen:

V_{in}: Nominal input voltage.

V_{out}: Desired output voltage. |V_{out}|=1.25*(1+R_B/R_A)

I_{out}: Desired output current

F_{min}: Minimum desired switching frequency at selected values for V_{in} and I_{out}.

V_{Ripple(P-P)}: Desired peak to peak output ripple voltage in practice, the calculated value will need to be increased due to the capacitor equivalent series resistance and board layout. The ripple voltage should be kept to a low value since it will directly effect the line and load regulation.



Application Information (Continuos)

Fig.1 Step-Down Converter

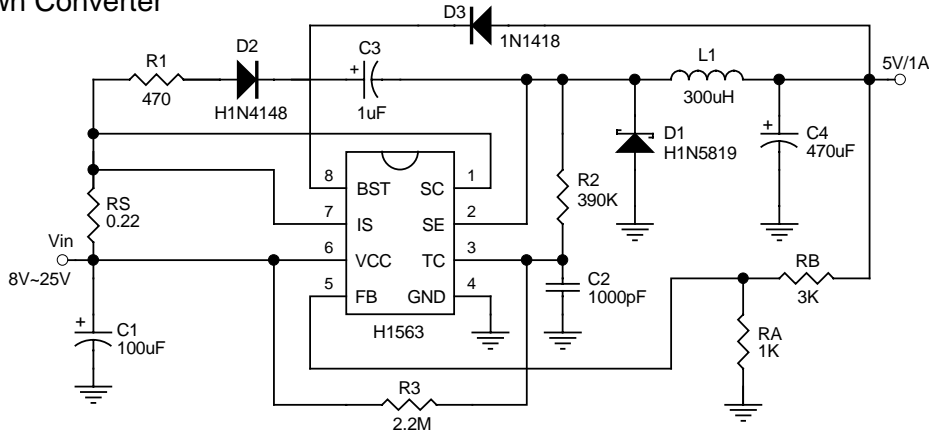

Line Regulation: 40mV ($V_{in}=10V\sim 20V$, @ $I_o=1A$)
 Load Regulation: 20mV ($V_{in}=15V$, @ $I_o=100mA\sim 1A$)
 Short Circuit Current: 1.3A ($V_{in}=15V$, @ $R_L=0.1\Omega$)

Fig.2 Step-Down Converter With External 5V Bootstrap

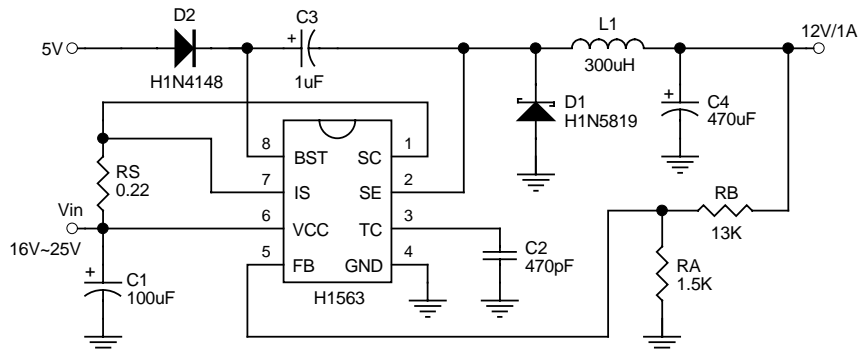
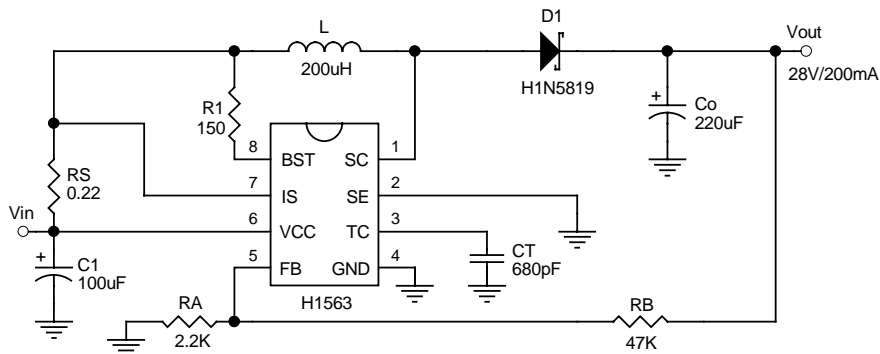

Fig.3 Step-Up Converter



Line Regulation: 100mV ($V_{in}=8V\sim 16V$, @ $I_o=200mA$)
 Load Regulation: 40mV ($V_{in}=12V$, @ $I_o=80mA\sim 200mA$)



Fig.4 Step-Up Converter With External NPN Switch

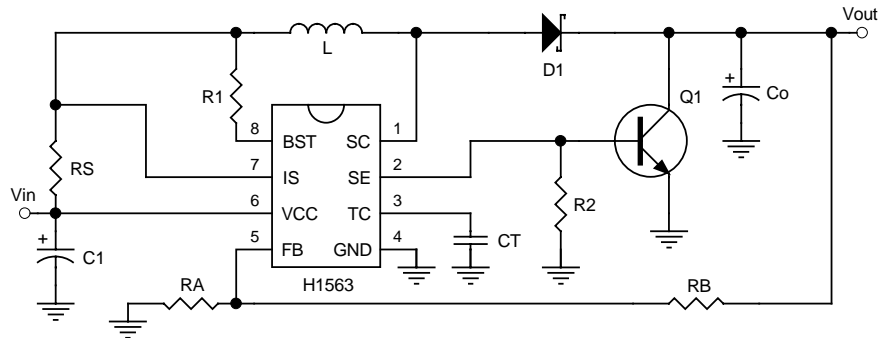
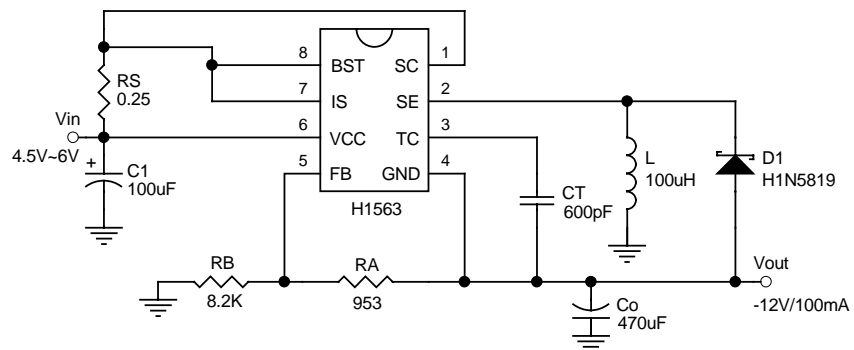

Fig.5 Inverting Converter



Line Regulation: 20mV ($V_{in}=4.5V\sim 6V$, @ $I_o=100mA$)
Load Regulation: 100mV ($V_{in}=5V$, @ $I_o=10mA\sim 100mA$)



H1563P Dimension (DIP-8P)

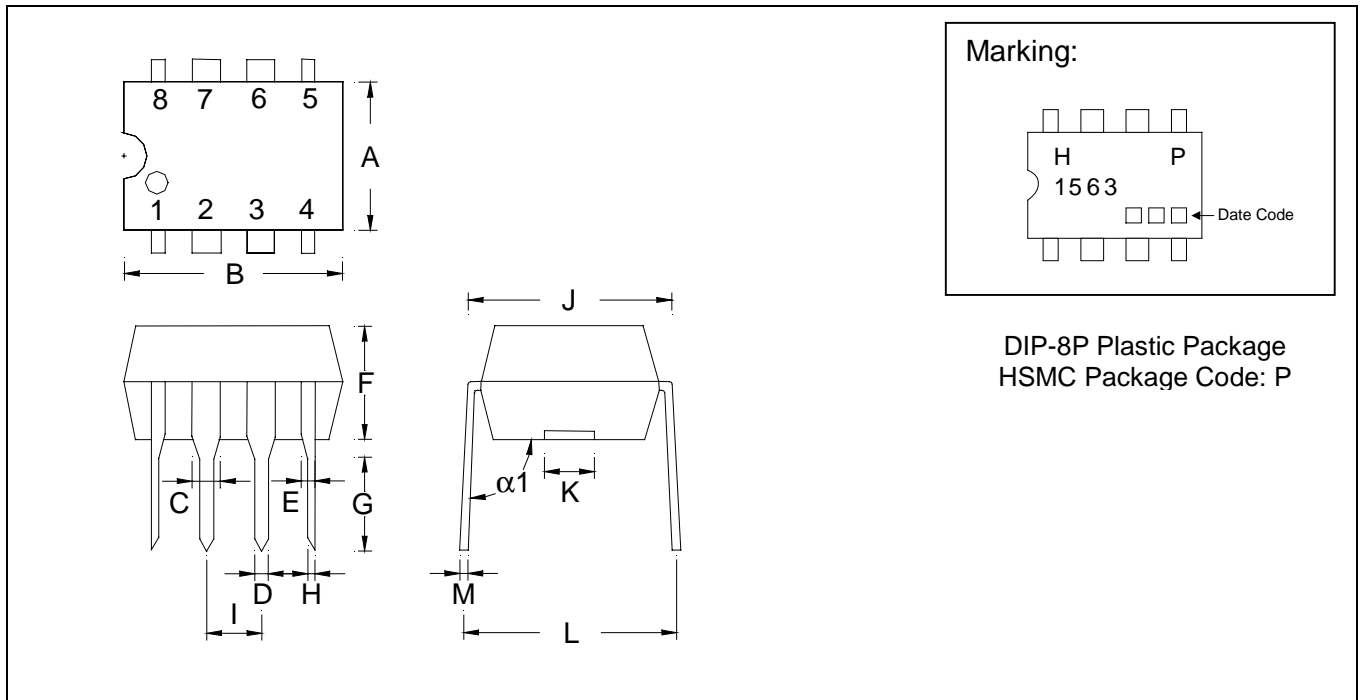

*: Typical

DIM	Inches		Millimeters		DIM	Inches		Millimeters	
	Min.	Max.	Min.	Max.		Min.	Max.	Min.	Max.
A	0.2480	0.2520	6.29	6.40	H	0.0150	0.0210	0.38	0.53
B	0.3630	0.3670	9.22	9.32	I	0.0898	0.1098	2.28	2.79
C	-	*0.0600	-	*1.52	J	0.2950	0.3050	7.49	7.74
D	-	*0.0500	-	*1.27	K	-	*0.1181	-	*3.00
E	-	*0.0390	-	*0.99	L	0.3370	0.7470	8.56	8.81
F	0.1280	0.1320	3.25	3.35	M	0.0090	0.0150	0.229	0.381
G	0.1250	0.1400	3.17	3.55	$\alpha 1$	94°	97°	94°	97°

- Notes: 1.Dimension and tolerance based on our Spec. dated Sep. 07,1997.
 2.Controlling dimension: millimeters.
 3.Maximum lead thickness includes lead finish thickness, and minimum lead thickness is the minimum thickness of base material.
 4.If there is any question with packing specification or packing method, please contact your local HSMC sales office.

Material:

- Lead: 42 Alloy; solder plating
- Mold Compound: Epoxy resin family, flammability solid burning class: UL94V-0



H1563S Dimension (SOP-8P)

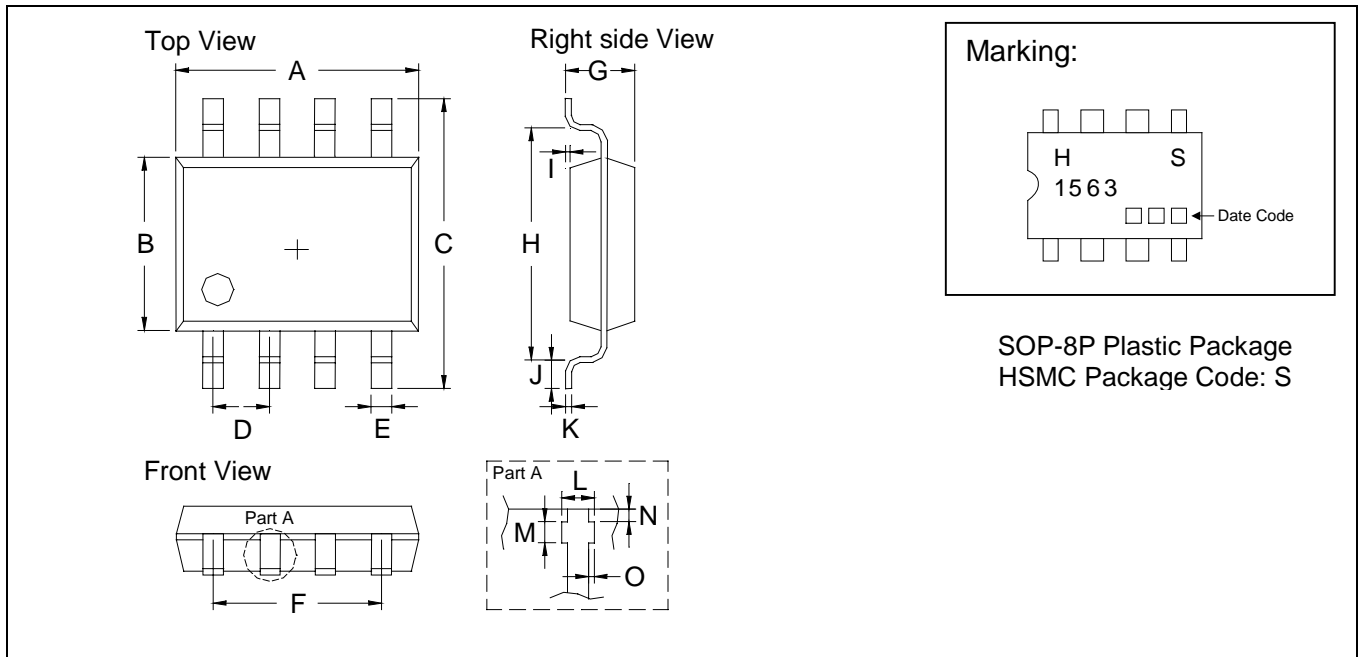

*: Typical

DIM	Inches		Millimeters		DIM	Inches		Millimeters	
	Min.	Max.	Min.	Max.		Min.	Max.	Min.	Max.
A	0.1909	0.2007	4.85	5.10	I	0.0019	0.0078	0.05	0.20
B	0.1515	0.1555	3.85	3.95	J	0.0118	0.0275	0.30	0.70
C	0.2283	0.2441	5.80	6.20	K	0.0074	0.0098	0.19	0.25
D	0.0480	0.0519	1.22	1.32	L	0.0145	0.0204	0.37	0.52
E	0.0145	0.0185	0.37	0.47	M	0.0090	0.0110	0.23	0.28
F	0.1472	0.1527	3.74	3.88	N	0.0031	0.0051	0.08	0.13
G	0.0570	0.0649	1.45	1.65	O	0.0000	0.0059	0.00	0.15
H	0.1889	0.2007	4.80	5.10					

- Notes:
- 1.Dimension and tolerance based on our Spec. dated Mar. 01, 2001.
 - 2.Controlling dimension: millimeters.
 - 3.Maximum lead thickness includes lead finish thickness, and minimum lead thickness is the minimum thickness of base material.
 - 4.If there is any question with packing specification or packing method, please contact your local HSMC sales office.

Material:

- Lead: 42 Alloy; solder plating
- Mold Compound: Epoxy resin family, flammability solid burning class: UL94V-0

Important Notice:

- All rights are reserved. Reproduction in whole or in part is prohibited without the prior written approval of HSMC.
- HSMC reserves the right to make changes to its products without notice.
- **HSMC semiconductor products are not warranted for use in Life-Support Applications, or systems.**
- HSMC assumes no liability for any consequence of customer product design, infringement of patents, or application assistance.

Head Office And Factory:

- **Head Office** (Hi-Sincerity Microelectronics Corp.): 10F.,No. 61, Sec. 2, Chung-Shan N. Rd. Taipei Taiwan R.O.C.
 Tel: 886-2-25212056 Fax: 886-2-25632712, 25368454
- **Factory 1:** No. 38, Kuang Fu S. Rd., Fu-Kou Hsin-Chu Industrial Park Hsin-Chu Taiwan. R.O.C
 Tel: 886-3-5983621~5 Fax: 886-3-5982931



LittleDiode supplies new, hard to find or obsolete electronic components and semiconductors all over the world.

With over two million different components listed you are sure to find the part you need.

Feel free to visit us today at our online store:

LittleDiode.com

Looking forward to providing you with the best possible service.