



# H34063AP

DC-TO-DC CONVERTER INTEGRATE CIRCUIT DEVICES

## Description

The H34063AP Series is a monolithic control circuit containing the primary functions required for DC-to-DC converters. These devices consist of an internal temperature compensated reference, comparator, controlled duty cycle oscillator with an active current limit circuit, driver and high current output switch. This series was specifically by Hi-Sincerity Microelectronics Corp.

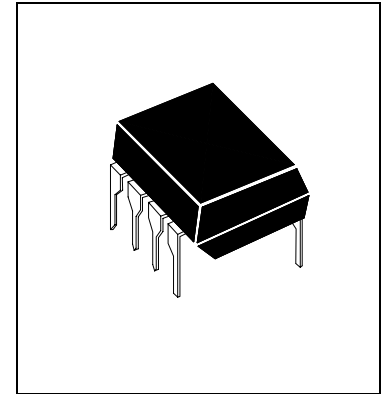

## Features

- 3V to 40V Input Voltage Operation
- Internal 1.6A Peak Current Switch
- Internal  $\pm 1.8\%$  Reference
- Low Quiescent Current at 1.6mA
- Frequency Operation from 100Hz~100KHz
- Current Limiting

## Applications

- Saver for Cellular Phone
- DC-DC Converter Module

## Typical Application Circuit

Fig1.Saver Circuit for Cellular Phone

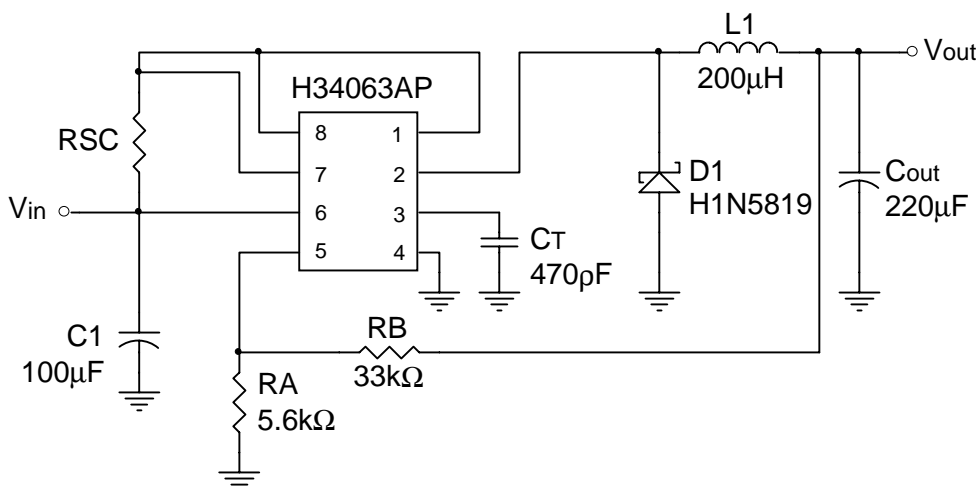



### Pin Connections

	Pin1:Switch Collector	Pin5:Comparator Inverting Input
	Pin2:Switch Emitter	Pin6:Vcc
	Pin3:Timing Capacitor	Pin7:lpk Sense
	Pin4:Gnd	Pin8:Driver Collector

### Absolute Maxium Rating

Supply Voltage .....	40 V
Comparator Input Voltage Range .....	-0.3V ~ 40 V
Switch Collector Voltage .....	40 V
Switch Emitter Voltage .....	40 V
Switch Collector to Emitter Voltage .....	40 V
Driver Collector Voltage .....	40 V
Switch Current .....	1.6 A
Power Dissipation DIP Package Ta=25°C .....	1.0 W
Thermal Resistance Junction To Air.....	125 °C / W
Operating Junction Temperature.....	125 °C
Operating Ambient Temperature Range .....	0 ~ 70 °C
Storage Temperature Range.....	-40 °C ~ 125 °C

### Electrical Characteristics (Vcc=5V,Ta=25°C, unless otherwise specified)

Parameter	Test Condition	Symbol	Min.	Typ.	Max.	Unit
<i>Oscillator</i>						
Charging Current	5.0V≤VCC≤40V	Ichg	24	35	42	uA
Discharge Current	5.0V≤VCC≤40V	Idischg	140	220	260	uA
Voltage Amplitude	Pin3	VOSC	-	0.6	-	V
Discharge to Charge Current Ratio	VIPK(Sense) =VCC	IDischg/Ichg	5.2	6.5	7.5	
Current Limit Sense Voltage	IChg=Idischg	VIPK(Sence)	250	300	350	mV
<i>Output Switch</i>						
Saturation Voltage, Darlington Connection	ISW=1.0A, VC(Driver)=VC(Switch)	VCE(Sat)	-	1.0	1.3	V
Saturation Voltage	ISW=1.0A, IC(Driver)=50mA (Forced β ≈ 20)	VCE(Sat)	-	0.4	0.7	V
DC Current Gain	ISW=1.0A, VCE=5.0V	hFE	50	75	-	V
Collector Off-State Current	VCE=30V	ICC(Off)	-	0.01	100	UA
<i>Comparator</i>						
Threshold Voltage	0°C≤Ta≤70°C	VFB	1.227	1.250	1.273	V
Threshold Voltage			1.210	-	1.29	
Threshold Voltage Line Regulation	3.0V≤VCC≤40V	Regline	-	1.5	6	mV
Input Bias Current	VIN=0V	IIB	-	-20	-400	nA
Supply Current	VIPK(Sence)=VCC VPin5>VFB, 5.0V≤VCC≤40V CT=0.0001uF,Pin2=Gnd Remaining pins open	ICC	-	1.6	3	mA



### Block Diagram

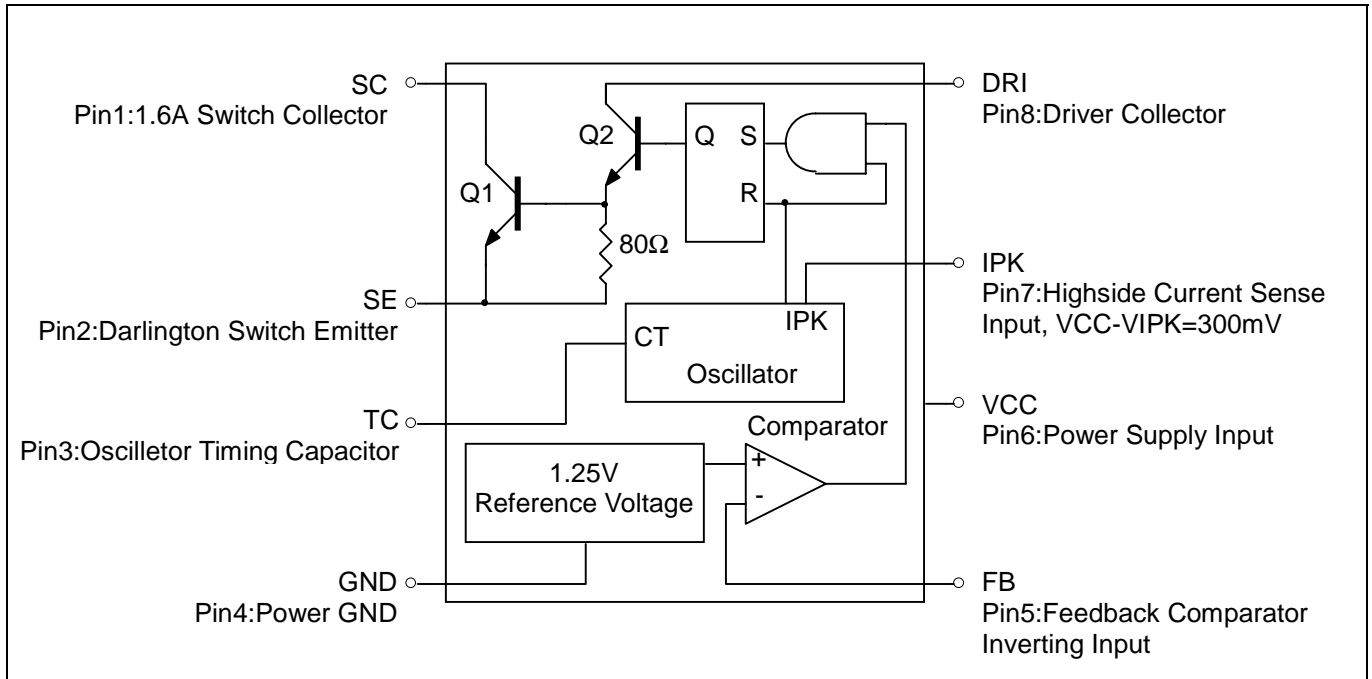

### Application Information

#### Design Formula Table

Calculation	Step-Down	Step-Up	Voltage-Inverting
ton / toff	$\frac{V_{out}+V_F}{V_{in(min)} - V_{sat}-V_{Out}}$	$\frac{V_{out}+V_F-V_{in(min)}}{V_{in(min)}-V_{sat}}$	$\frac{ V_{out}  + V_F}{V_{in}-V_{sat}}$
(ton + toff) max	1/Fmin	1/Fmin	1/Fmin
CT	$4*10^{-5}ton$	$4*10^{-5}ton$	$4*10^{-5}ton$
IC(switch)	$2*I_{out(max)}$	$2*I_{out(max)}(ton+toff/toff)$	$2*I_{out(max)}(ton+toff/toff)$
RS	$0.3 / IC(switch)$	$0.3 / IC(switch)$	$0.3 / IC(switch)$
L(min)	$\frac{(V_{in(min)}-V_{sat}-V_{out})}{IC(switch)} * ton(max)$	$\frac{(V_{in(min)}-V_{sat})}{IC(switch)} * ton(max)$	$\frac{(V_{in(min)}-V_{sat})}{IC(switch)} * ton(max)$
Co	$\frac{IC(switch)*(ton+toff)}{8V_{Ripple(P-P)}}$	$\frac{I_{out}*ton}{V_{Ripple(P-P)}}$	$\frac{I_{out}*ton}{V_{Ripple(P-P)}}$

Vsat : Saturation voltage of the output switch.

VF : Forward voltage drop of the ringback rectifier.

The following power supply characteristics must be chosen :

Vin : Nominal input voltage.

Vout : Desired output voltage.  $|V_{out}|=1.25*(1+R_B/R_A)$

Iout- Desired output current

Fmin : Minimum desired output switching frequency at the selected values for Vin and Iout.

VRipple(P-P) : Desired peak to peak output ripple voltage in practice, the calculated value will need to be increased due to the capacitor equivalent series resistance and board layout. The ripple voltage should be kept to a low value since it will directly effect the line and load regulation.



### Application Information (Continuos)

Fig.2 Step-Up Converter

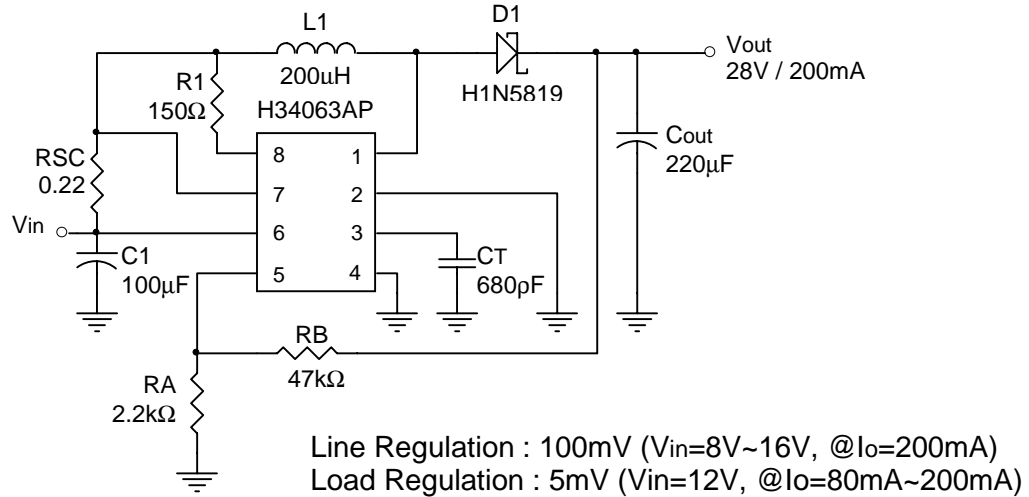

Fig.3 Step-Up Converter With External NPN Switch

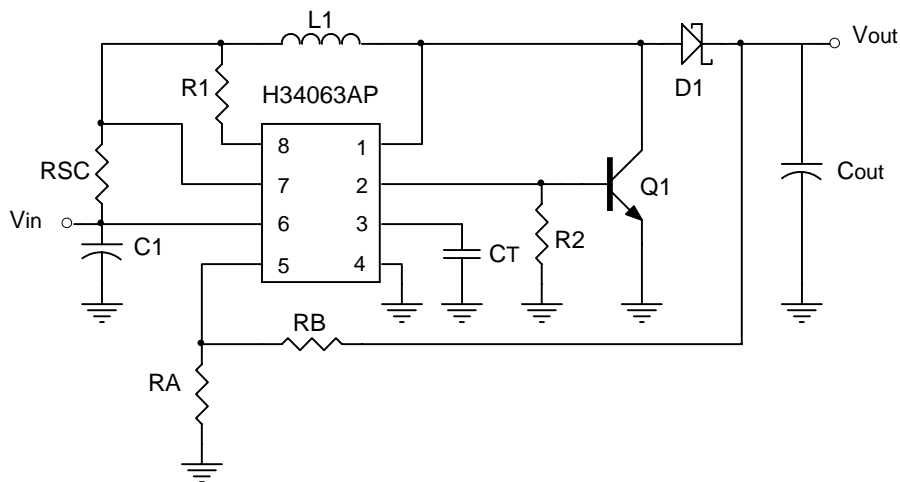

Fig.4 Step-Down Converter

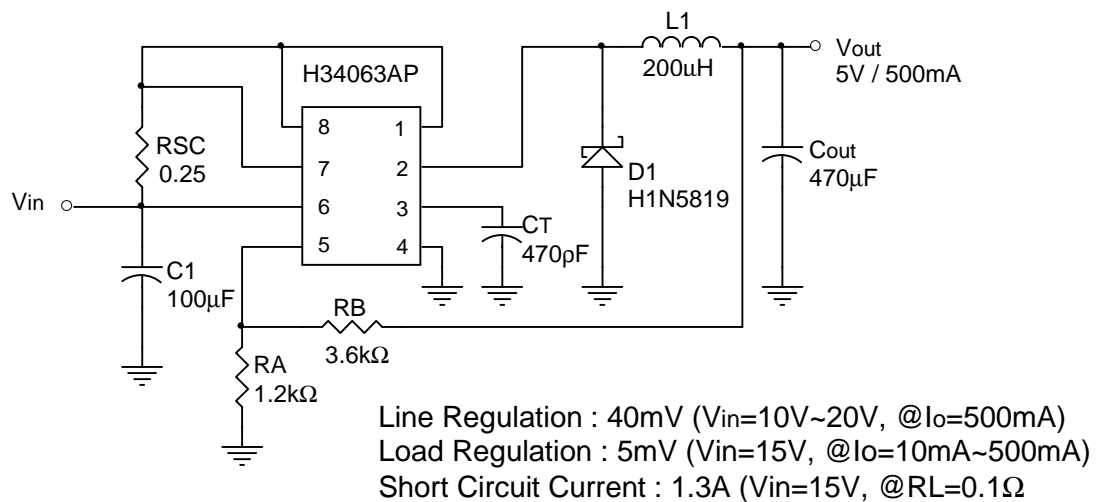



Fig.5 Step-Down Converter With External PNP Saturation Switch

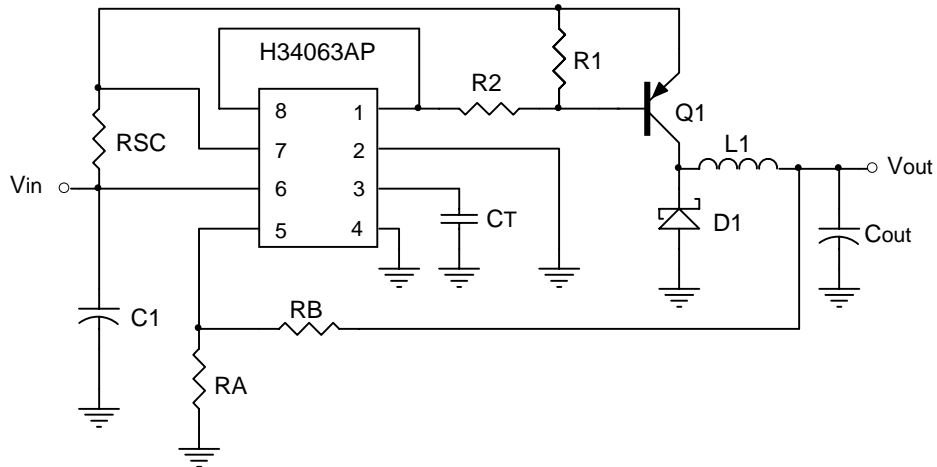

Fig.6 Voltage Inverting Converter

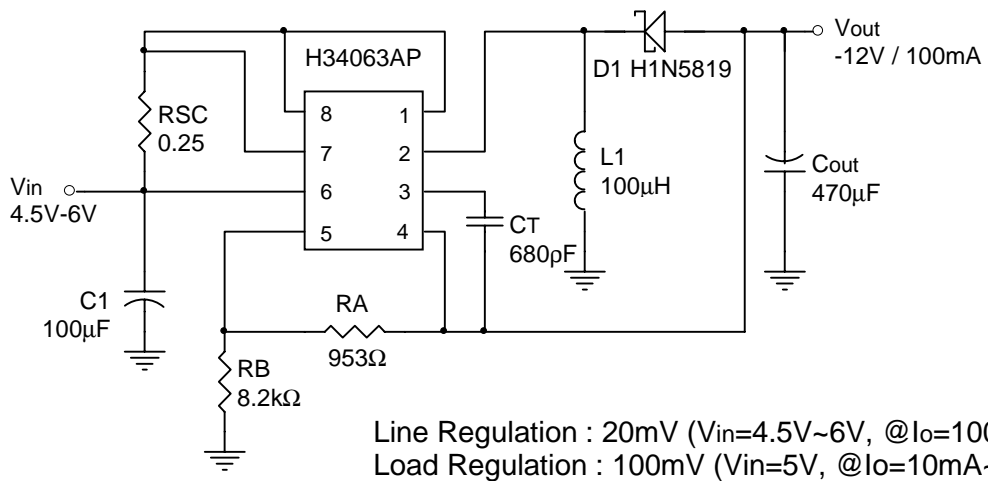
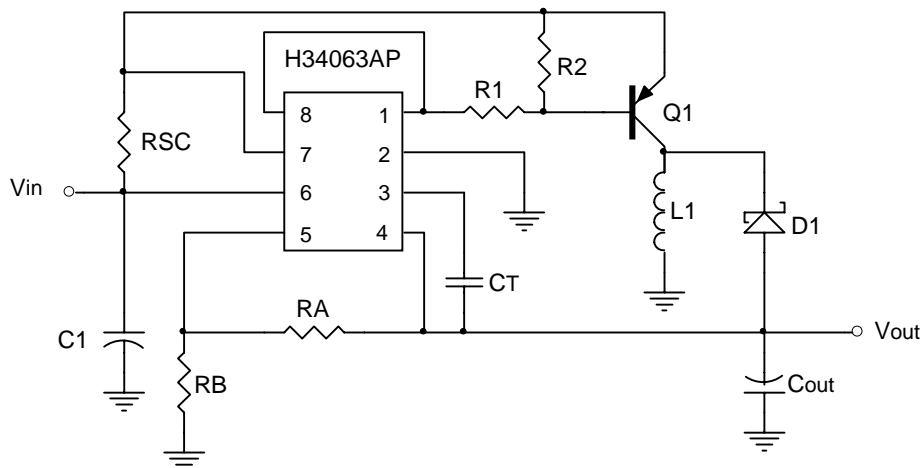
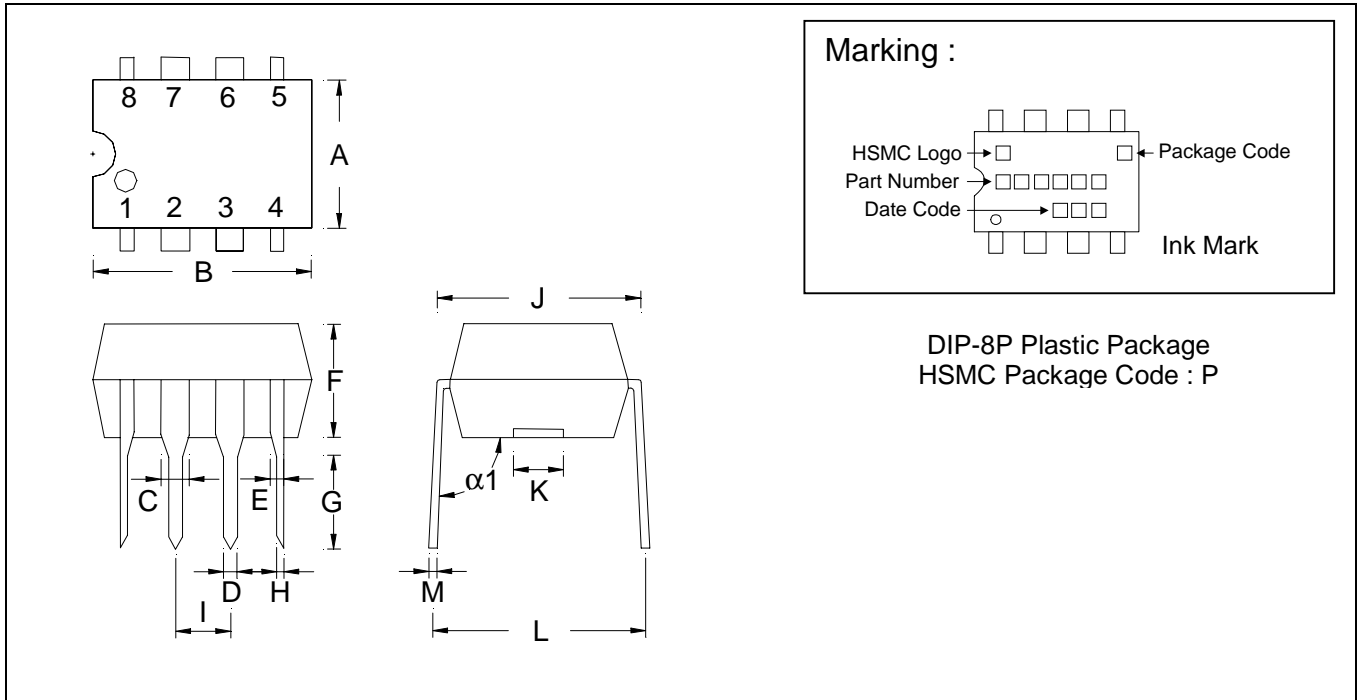

Fig.7 Voltage Inverting Converter With External PNP Saturation Switch





### DIP-8P Dimension



\*:Typical

DIM	Inches		Millimeters		DIM	Inches		Millimeters	
	Min.	Max.	Min.	Max.		Min.	Max.	Min.	Max.
A	0.2480	0.2520	6.29	6.40	H	0.0150	0.0210	0.38	0.53
B	0.3630	0.3670	9.22	9.32	I	0.0898	0.1098	2.28	2.79
C	-	*0.0600	-	*1.52	J	0.2950	0.3050	7.49	7.74
D	-	*0.0500	-	*1.27	K	-	*0.1181	-	*3.00
E	-	*0.0390	-	*0.99	L	0.3370	0.7470	8.56	8.81
F	0.1280	0.1320	3.25	3.35	M	0.0090	0.0150	0.229	0.381
G	0.1250	0.1400	3.17	3.55	$\alpha 1$	94°	97°	94°	97°

- Notes :**
- 1.Dimension and tolerance based on our Spec. dated Sep. 07,1997.
  - 2.Controlling dimension : millimeters.
  - 3.Maximum lead thickness includes lead finish thickness, and minimum lead thickness is the minimum thickness of base material.
  - 4.If there is any question with packing specification or packing method, please contact your local HSMC sales office.

**Material :**

- Lead : 42 Alloy ; solder plating
- Mold Compound : Epoxy resin family, flammability solid burning class:UL94V-0

**Important Notice :**

- All rights are reserved. Reproduction in whole or in part is prohibited without the prior written approval of HSMC.
- HSMC reserves the right to make changes to its products without notice.
- **HSMC semiconductor products are not warranted to be suitable for use in Life-Support Applications, or systems.**
- HSMC assumes no liability for any consequence of customer product design, infringement of patents, or application assistance.

**Head Office And Factory :**

- **Head Office** (Hi-Sincerity Microelectronics Corp.) : 10F.,No. 61, Sec. 2, Chung-Shan N. Rd. Taipei Taiwan R.O.C.  
 Tel : 886-2-25212056 Fax : 886-2-25632712, 25368454
- **Factory 1** : No. 38, Kuang Fu S. Rd., Fu-Kou Hsin-Chu Industrial Park Hsin-Chu Taiwan. R.O.C  
 Tel : 886-3-5983621~5 Fax : 886-3-5982931
- **Factory 2** : No. 17-1, Ta-Tung Rd., Fu-Kou Hsin-Chu Industrial Park Hsin-Chu Taiwan. R.O.C  
 Tel : 886-3-5977061 Fax : 886-3-5979220



LittleDiode supplies new, hard to find or obsolete electronic components and semiconductors all over the world.

With over two million different components listed you are sure to find the part you need.

Feel free to visit us today at our online store:

[LittleDiode.com](http://LittleDiode.com)

Looking forward to providing you with the best possible service.