

# LM317L

## 3-Terminal Adjustable Regulator

### General Description

The LM317L is an adjustable 3-terminal positive voltage regulator capable of supplying 100mA over a 1.2V to 37V output range. It is exceptionally easy to use and requires only two external resistors to set the output voltage. Further, both line and load regulation are better than standard fixed regulators. Also, the LM317L is available packaged in a standard TO-92 transistor package which is easy to use.

In addition to higher performance than fixed regulators, the LM317L offers full overload protection. Included on the chip are current limit, thermal overload protection and safe area protection. All overload protection circuitry remains fully functional even if the adjustment terminal is disconnected.

Normally, no capacitors are needed unless the device is situated more than 6 inches from the input filter capacitors in which case an input bypass is needed. An optional output capacitor can be added to improve transient response. The adjustment terminal can be bypassed to achieve very high ripple rejection ratios which are difficult to achieve with standard 3-terminal regulators.

Besides replacing fixed regulators, the LM317L is useful in a wide variety of other applications. Since the regulator is "floating" and sees only the input-to-output differential voltage, supplies of several hundred volts can be regulated as long as the maximum input-to-output differential is not exceeded.

Also, it makes an especially simple adjustable switching regulator, a programmable output regulator, or by connecting a fixed resistor between the adjustment and output, the LM317L can be used as a precision current regulator. Supplies with electronic shutdown can be achieved by clamping the adjustment terminal to ground which programs the output to 1.2V where most loads draw little current.

The LM317L is available in a standard TO-92 transistor package, the SO-8 package, and 6-Bump micro SMD package. The LM317L is rated for operation over a  $-25^{\circ}\text{C}$  to  $125^{\circ}\text{C}$  range.

### Features

- Adjustable output down to 1.2V
- Guaranteed 100 mA output current
- Line regulation typically 0.01%V
- Load regulation typically 0.1%
- Current limit constant with temperature
- Eliminates the need to stock many voltages
- Standard 3-lead transistor package
- 80 dB ripple rejection
- Available in TO-92, SO-8, or 6-Bump micro SMD package
- Output is short circuit protected
- See AN-1112 for micro SMD considerations

### Connection Diagrams

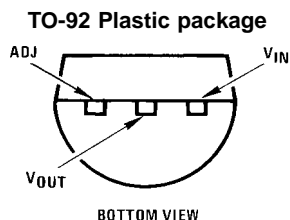

DS009064-4

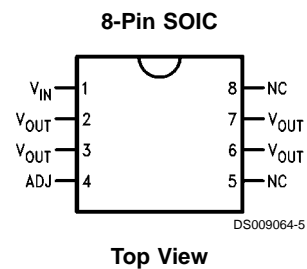

DS009064-5

**Connection Diagrams** (Continued)

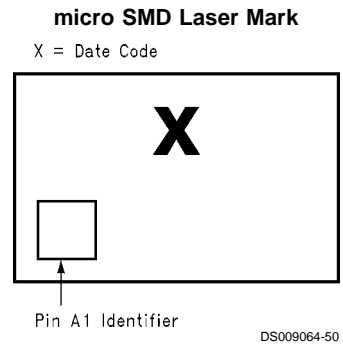
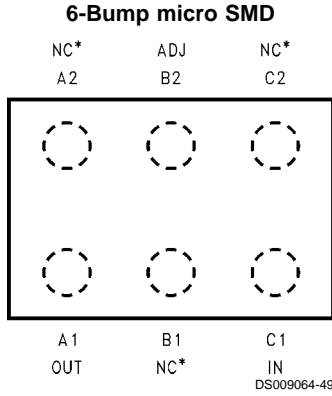

\*NC = Not Internally connected.

**Top View  
(Bump Side Down)**

| Package          | Part Number  | Package Marking | Media Transport         | NSC Drawing |
|------------------|--------------|-----------------|-------------------------|-------------|
| TO-92            | LM317LZ      | LM317LZ         | 1.8k Units per Box      | Z03A        |
| 8-Pin SOIC       | LM317LM      | LM317LM         | Rails                   | M08A        |
| 6-Bump micro SMD | * LM317LIBP  | —               | 250 Units Tape and Reel | BPA06HPB    |
|                  | * LM317LIBPX | —               | 3k Units Tape and Reel  |             |

**Note:** The micro SMD package marking is a single digit manufacturing Date Code only.

**Absolute Maximum Ratings** (Note 1)

If Military/Aerospace specified devices are required, please contact the National Semiconductor Sales Office/Distributors for availability and specifications.

|                                      |                    |
|--------------------------------------|--------------------|
| Power Dissipation                    | Internally Limited |
| Input-Output Voltage Differential    | 40V                |
| Operating Junction Temperature Range | -40°C to +125°C    |

|   |                 |
|---|-----------------|
| Storage Temperature                     | -55°C to +150°C |
| Lead Temperature (Soldering, 4 seconds) | 260°C           |
| Output is Short Circuit Protected       |                 |
| ESD rating to be determined.            |                 |

**Electrical Characteristics** (Note 2)

| Parameter                               | Conditions   | Min       | Typ                      | Max        | Units  |
|---|--|-----------|--------------------------|------------|--|
| Line Regulation                         | $T_J = 25^\circ\text{C}$ , $3\text{V} \leq (V_{\text{IN}} - V_{\text{OUT}}) \leq 40\text{V}$ , $I_L \leq 20\text{mA}$ (Note 3)                             |           | 0.01                     | 0.04       | %/V  |
| Load Regulation                         | $T_J = 25^\circ\text{C}$ , $5\text{mA} \leq I_{\text{OUT}} \leq I_{\text{MAX}}$ , (Note 3)   |           | 0.1                      | 0.5        | %  |
| Thermal Regulation                      | $T_J = 25^\circ\text{C}$ , 10ms Pulse  |           | 0.04                     | 0.2        | %/W  |
| Adjustment Pin Current                  |  |           | 50                       | 100        | $\mu\text{A}$  |
| Adjustment Pin Current Change           | $5\text{mA} \leq I_L \leq 100\text{mA}$<br>$3\text{V} \leq (V_{\text{IN}} - V_{\text{OUT}}) \leq 40\text{V}$ , $P \leq 625\text{mW}$                       |           | 0.2                      | 5          | $\mu\text{A}$  |
| Reference Voltage                       | $3\text{V} \leq (V_{\text{IN}} - V_{\text{OUT}}) \leq 40\text{V}$ , (Note 4)<br>$5\text{mA} \leq I_{\text{OUT}} \leq 100\text{mA}$ , $P \leq 625\text{mW}$ | 1.20      | 1.25                     | 1.30       | V  |
| Line Regulation                         | $3\text{V} \leq (V_{\text{IN}} - V_{\text{OUT}}) \leq 40\text{V}$ , $I_L \leq 20\text{mA}$ (Note 3)  |           | 0.02                     | 0.07       | %/V  |
| Load Regulation                         | $5\text{mA} \leq I_{\text{OUT}} \leq 100\text{mA}$ , (Note 3)  |           | 0.3                      | 1.5        | %  |
| Temperature Stability                   | $T_{\text{MIN}} \leq T_J \leq T_{\text{MAX}}$  |           | 0.65                     |            | %  |
| Minimum Load Current                    | $(V_{\text{IN}} - V_{\text{OUT}}) \leq 40\text{V}$<br>$3\text{V} \leq (V_{\text{IN}} - V_{\text{OUT}}) \leq 15\text{V}$                                    |           | 3.5<br>1.5               | 5<br>2.5   | mA   |
| Current Limit                           | $3\text{V} \leq (V_{\text{IN}} - V_{\text{OUT}}) \leq 13\text{V}$<br>$(V_{\text{IN}} - V_{\text{OUT}}) = 40\text{V}$                                       | 100<br>25 | 200<br>50                | 300<br>150 | mA   |
| Rms Output Noise, % of $V_{\text{OUT}}$ | $T_J = 25^\circ\text{C}$ , $10\text{Hz} \leq f \leq 10\text{kHz}$  |           | 0.003                    |            | %  |
| Ripple Rejection Ratio                  | $V_{\text{OUT}} = 10\text{V}$ , $f = 120\text{Hz}$ , $C_{\text{ADJ}} = 0$<br>$C_{\text{ADJ}} = 10\mu\text{F}$  |           | 65<br>66                 |            | dB<br>dB   |
| Long-Term Stability                     | $T_J = 125^\circ\text{C}$ , 1000 Hours   |           | 0.3                      | 1          | %  |
| Thermal Resistance Junction to Ambient  | Z Package 0.4" Leads<br>Z Package 0.125 Leads<br>SO-8 Package<br>6-Bump micro SMD  |           | 180<br>160<br>165<br>290 |            | $^\circ\text{C/W}$<br>$^\circ\text{C/W}$<br>$^\circ\text{C/W}$<br>$^\circ\text{C/W}$ |
| Thermal Rating of SO Package            |  |           | 165                      |            | $^\circ\text{C/W}$   |

**Note 1:** "Absolute Maximum Ratings" indicate limits beyond which damage to the device may occur. Operating Ratings indicate conditions for which the device is functional, but do not guarantee specific performance limits.

**Note 2:** Unless otherwise noted, these specifications apply:  $-25^\circ\text{C} \leq T_J \leq 125^\circ\text{C}$  for the LM317L;  $V_{\text{IN}} - V_{\text{OUT}} = 5\text{V}$  and  $I_{\text{OUT}} = 40\text{mA}$ . Although power dissipation is internally limited, these specifications are applicable for power dissipations up to 625 mW.  $I_{\text{MAX}}$  is 100 mA.

**Note 3:** Regulation is measured at constant junction temperature, using pulse testing with a low duty cycle. Changes in output voltage due to heating effects are covered under the specification for thermal regulation.

**Note 4:** Thermal resistance of the TO-92 package is  $180^\circ\text{C/W}$  junction to ambient with 0.4" leads from a PC board and  $160^\circ\text{C/W}$  junction to ambient with 0.125" lead length to PC board.

# Typical Performance Characteristics (Output capacitor = 0 $\mu$ F unless otherwise noted.)

## Load Regulation

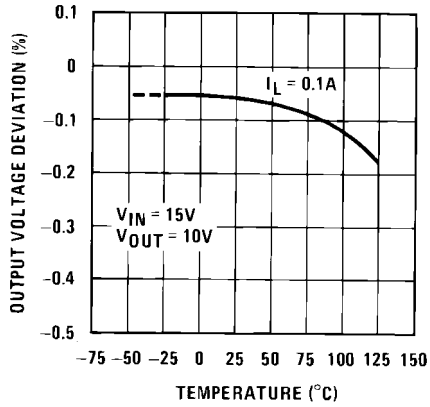

## Current Limit

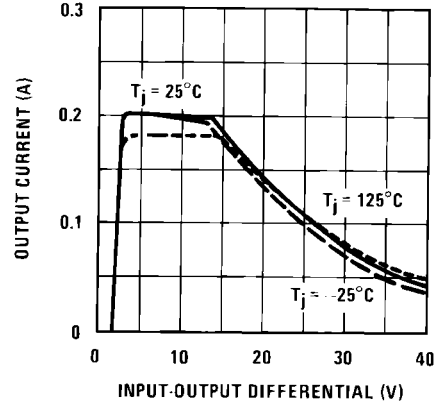

## Adjustment Current

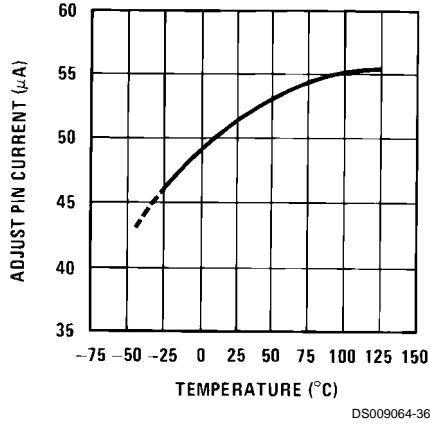

## Dropout Voltage

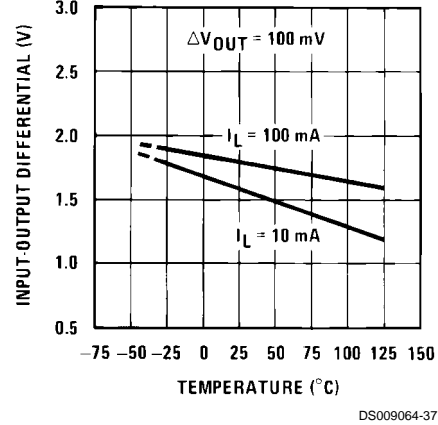

## Reference Voltage Temperature Stability

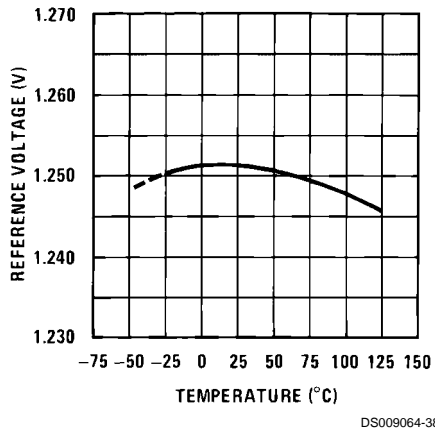

## Minimum Operating Current

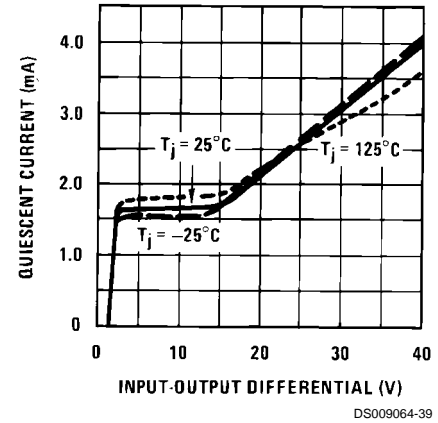

# Typical Performance Characteristics (Output capacitor = 0μF unless otherwise noted.) (Continued)

Ripple Rejection

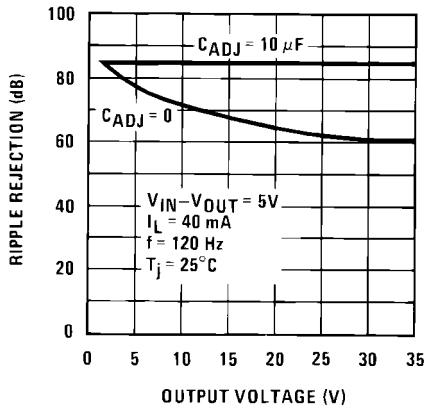

DS009064-40

Ripple Rejection

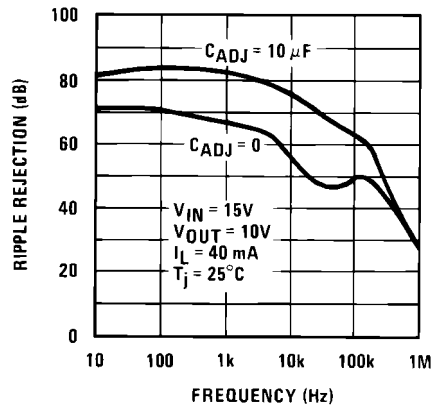

DS009064-41

Output Impedance

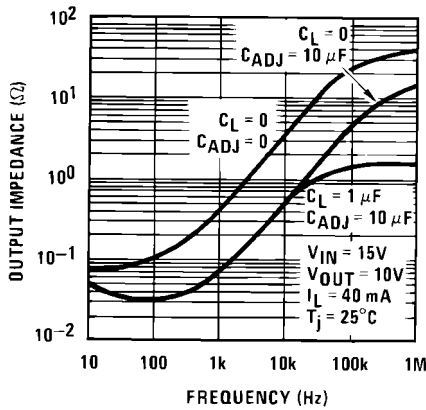

DS009064-42

Line Transient Response

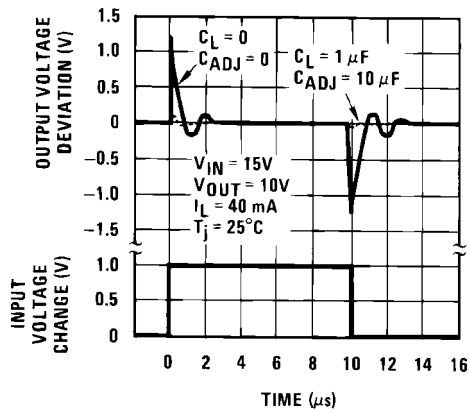

DS009064-43

Load Transient Response

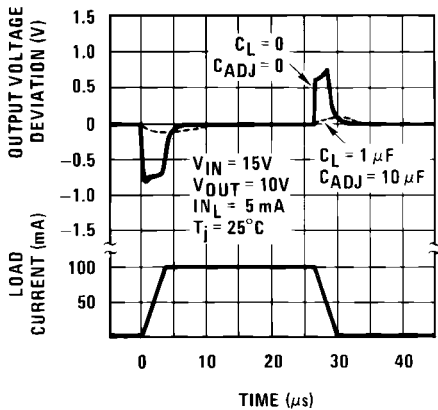

DS009064-44

Thermal Regulation

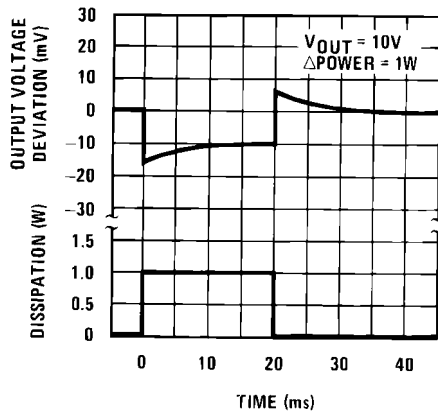

DS009064-45

## Application Hints

In operation, the LM317L develops a nominal 1.25V reference voltage,  $V_{REF}$ , between the output and adjustment terminal. The reference voltage is impressed across program resistor R1 and, since the voltage is constant, a constant current  $I_1$  then flows through the output set resistor R2, giving an output voltage of

$$V_{OUT} = V_{REF} \left( 1 + \frac{R2}{R1} \right) + I_{ADJ}(R2)$$

Since the 100 $\mu$ A current from the adjustment terminal represents an error term, the LM317L was designed to minimize  $I_{ADJ}$  and make it very constant with line and load changes. To do this, all quiescent operating current is returned to the output establishing a minimum load current requirement. If there is insufficient load on the output, the output will rise.

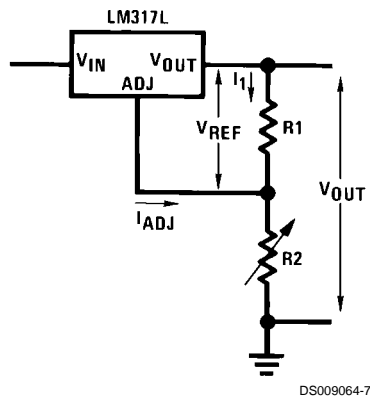

FIGURE 1.

### External Capacitors

An input bypass capacitor is recommended in case the regulator is more than 6 inches away from the usual large filter capacitor. A 0.1 $\mu$ F disc or 1 $\mu$ F solid tantalum on the input is suitable input bypassing for almost all applications. The device is more sensitive to the absence of input bypassing when adjustment or output capacitors are used, but the above values will eliminate the possibility of problems.

The adjustment terminal can be bypassed to ground on the LM317L to improve ripple rejection and noise. This bypass capacitor prevents ripple and noise from being amplified as the output voltage is increased. With a 10 $\mu$ F bypass capacitor 80 dB ripple rejection is obtainable at any output level. Increases over 10 $\mu$ F do not appreciably improve the ripple rejection at frequencies above 120Hz. If the bypass capacitor is used, it is sometimes necessary to include protection diodes to prevent the capacitor from discharging through internal low current paths and damaging the device.

In general, the best type of capacitors to use is solid tantalum. *Solid tantalum capacitors have low impedance even at high frequencies.* Depending upon capacitor construction, it takes about 25 $\mu$ F in aluminum electrolytic to equal 1 $\mu$ F solid tantalum at high frequencies. Ceramic capacitors are also good at high frequencies; but some types have a large decrease in capacitance at frequencies around 0.5MHz. For this reason, a 0.01 $\mu$ F disc may seem to work better than a 0.1 $\mu$ F disc as a bypass.

Although the LM317L is stable with no output capacitors, like any feedback circuit, certain values of external capacitance can cause excessive ringing. This occurs with values be-

tween 500 pF and 5000 pF. A 1 $\mu$ F solid tantalum (or 25 $\mu$ F aluminum electrolytic) on the output swamps this effect and insures stability.

### Load Regulation

The LM317L is capable of providing extremely good load regulation but a few precautions are needed to obtain maximum performance. The current set resistor connected between the adjustment terminal and the output terminal (usually 240 $\Omega$ ) should be tied directly to the output of the regulator rather than near the load. This eliminates line drops from appearing effectively in series with the reference and degrading regulation. For example, a 15V regulator with 0.05 $\Omega$  resistance between the regulator and load will have a load regulation due to line resistance of 0.05 $\Omega$  x  $I_L$ . If the set resistor is connected near the load the effective line resistance will be 0.05 $\Omega$  (1 + R2/R1) or in this case, 11.5 times worse.

Figure 2 shows the effect of resistance between the regulator and 240 $\Omega$  set resistor.

With the TO-92 package, it is easy to minimize the resistance from the case to the set resistor, by using two separate leads to the output pin. The ground of R2 can be returned near the ground of the load to provide remote ground sensing and improve load regulation.

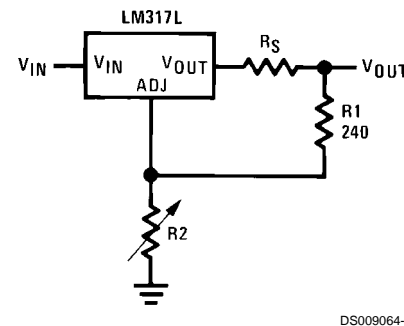

FIGURE 2. Regulator with Line Resistance in Output Lead

### Thermal Regulation

When power is dissipated in an IC, a temperature gradient occurs across the IC chip affecting the individual IC circuit components. With an IC regulator, this gradient can be especially severe since power dissipation is large. Thermal regulation is the effect of these temperature gradients on output voltage (in percentage output change) per watt of power change in a specified time. Thermal regulation error is independent of electrical regulation or temperature coefficient, and occurs within 5ms to 50ms after a change in power dissipation. Thermal regulation depends on IC layout as well as electrical design. The thermal regulation of a voltage regulator is defined as the percentage change of  $V_{OUT}$ , per watt, within the first 10ms after a step of power is applied. The LM317L specification is 0.2%/W, maximum.

In the Thermal Regulation curve at the bottom of the Typical Performance Characteristics page, a typical LM317L's output changes only 7mV (or 0.07% of  $V_{OUT} = -10V$ ) when a 1W pulse is applied for 10 ms. This performance is thus well inside the specification limit of 0.2%/W x 1W = 0.2% maximum. When the 1W pulse is ended, the thermal regulation again shows a 7 mV change as the gradients across the LM317L chip die out. Note that the load regulation error of about 14 mV (0.14%) is additional to the thermal regulation error.

## Application Hints (Continued)

### Protection Diodes

When external capacitors are used with *any* IC regulator it is sometimes necessary to add protection diodes to prevent the capacitors from discharging through low current points into the regulator. Most 10 $\mu$ F capacitors have low enough internal series resistance to deliver 20A spikes when shorted. Although the surge is short, there is enough energy to damage parts of the IC.

When an output capacitor is connected to a regulator and the input is shorted, the output capacitor will discharge into the output of the regulator. The discharge current depends on the value of the capacitor, the output voltage of the regulator, and the rate of decrease of  $V_{IN}$ . In the LM317L,

this discharge path is through a large junction that is able to sustain a 2A surge with no problem. This is not true of other types of positive regulators. For output capacitors of 25  $\mu$ F or less, the LM317L's ballast resistors and output structure limit the peak current to a low enough level so that there is no need to use a protection diode.

The bypass capacitor on the adjustment terminal can discharge through a low current junction. Discharge occurs when *either* the input or output is shorted. Internal to the LM317L is a 50 $\Omega$  resistor which limits the peak discharge current. No protection is needed for output voltages of 25V or less and 10 $\mu$ F capacitance. *Figure 3* shows an LM317L with protection diodes included for use with outputs greater than 25V and high values of output capacitance.

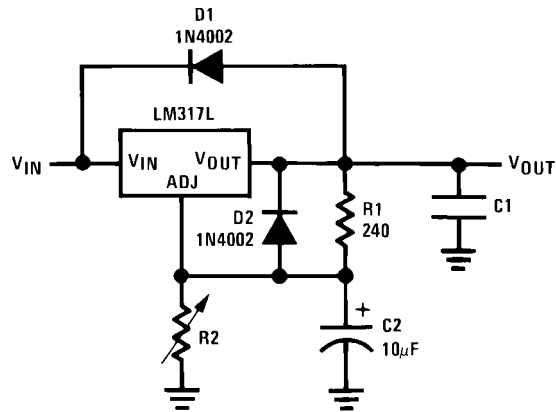

DS009064-9

$$V_{OUT} = 1.25V \left( 1 + \frac{R2}{R1} \right) I_{ADJ} R2$$

D1 protects against C1  
D2 protects against C2

**FIGURE 3. Regulator with Protection Diodes**

### LM317L micro SMD Light Sensitivity

Exposing the LM317L micro SMD package to bright sunlight may cause the  $V_{REF}$  to drop. In a normal office environment of fluorescent lighting the output is not affected. The LM317

micro SMD does not sustain permanent damage from light exposure. Removing the light source will cause LM317L's  $V_{REF}$  to recover to the proper value.



# Typical Applications

## Digitally Selected Outputs

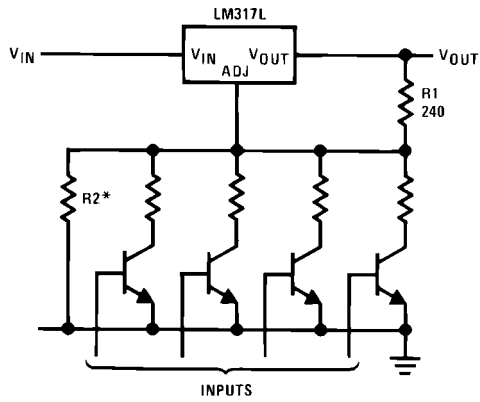

DS009064-11

\*Sets maximum  $V_{OUT}$

## High Gain Amplifier

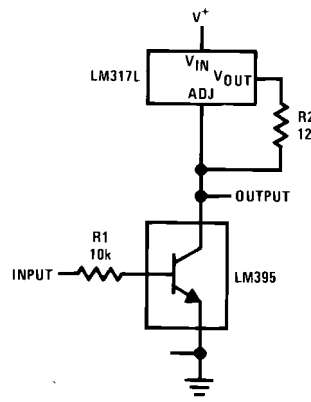

DS009064-12

## Adjustable Current Limiter

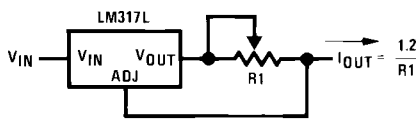

DS009064-13

$12 \leq R1 \leq 240$

## Precision Current Limiter

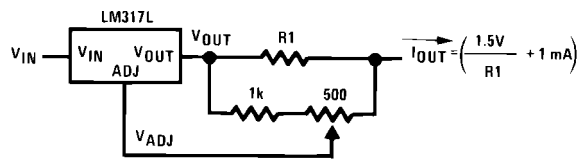

DS009064-14

## Slow Turn-On 15V Regulator

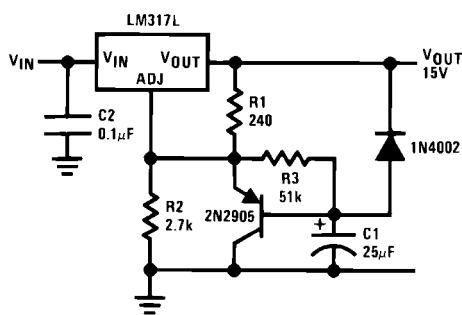

DS009064-15

## Adjustable Regulator with Improved Ripple Rejection

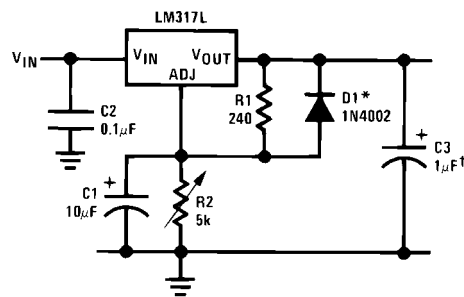

DS009064-16

†Solid tantalum

\*Discharges C1 if output is shorted to ground

# Typical Applications (Continued)

### High Stability 10V Regulator

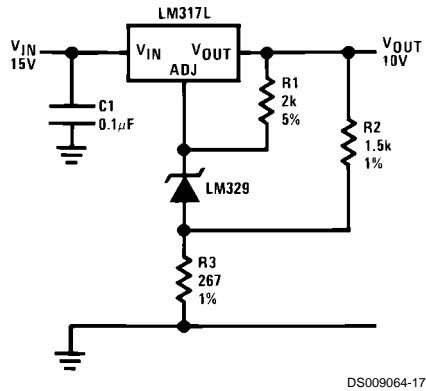

DS009064-17

### Adjustable Regulator with Current Limiter

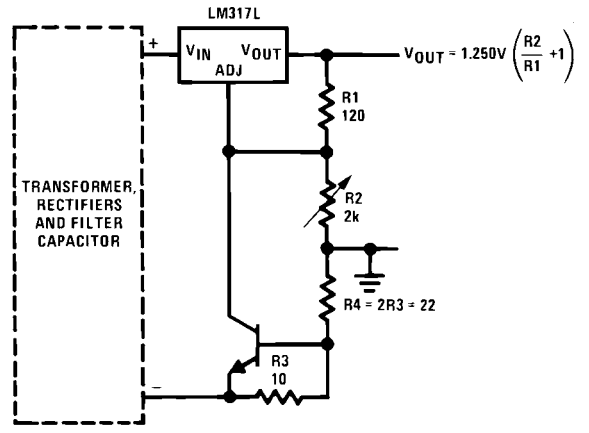

DS009064-18

Short circuit current is approximately  $600 \text{ mV}/R3$ , or 60mA (compared to LM317LZ's 200mA current limit).  
At 25mA output only 3/4V of drop occurs in R3 and R4.

### 0V–30V Regulator

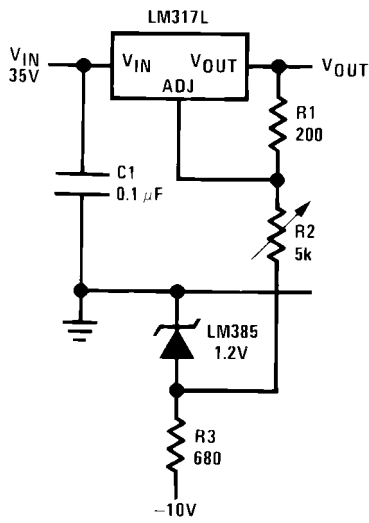

DS009064-19

Full output current not available at high input-output voltages

### Regulator With 15mA Short Circuit Current

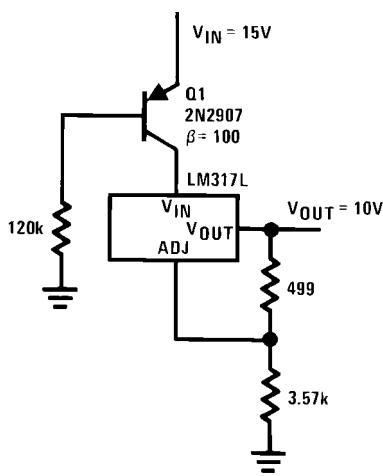

DS009064-20

### Power Follower

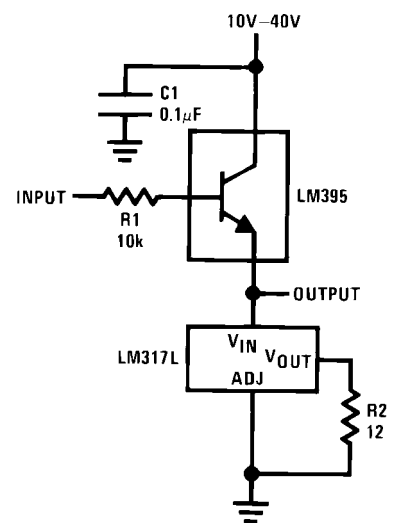

DS009064-21

### Adjusting Multiple On-Card Regulators with Single Control\*

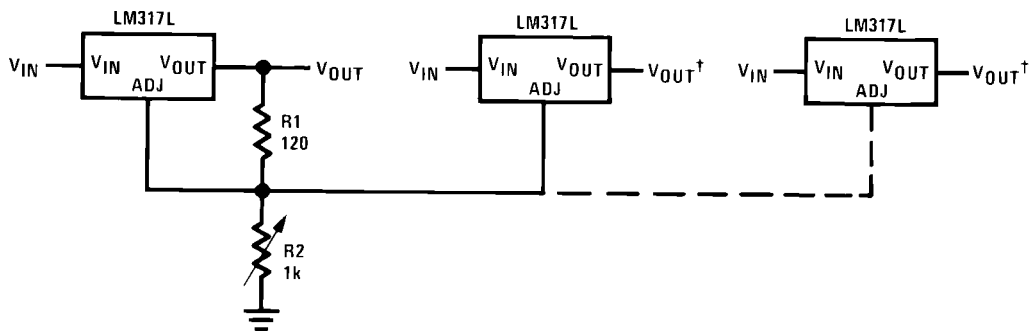

DS009064-22

\*All outputs within  $\pm 100\text{mV}$   
†Minimum load  $-5\text{mA}$

# Typical Applications (Continued)

100mA Current Regulator

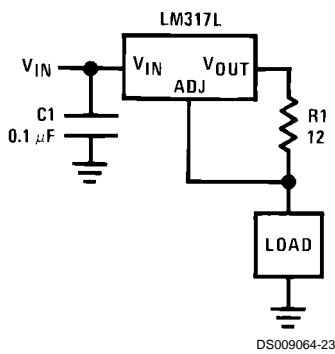

1.2V–12V Regulator with Minimum Program Current

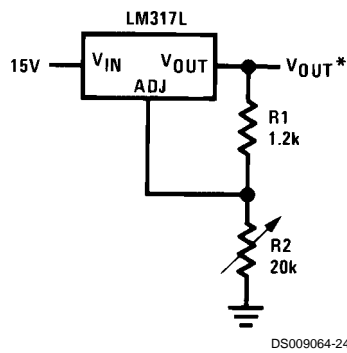

\*Minimum load current ≈ 2 mA

50mA Constant Current Battery Charger for Nickel-Cadmium Batteries

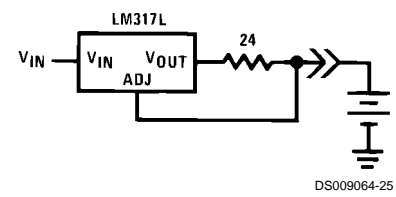

5V Logic Regulator with Electronic Shutdown\*

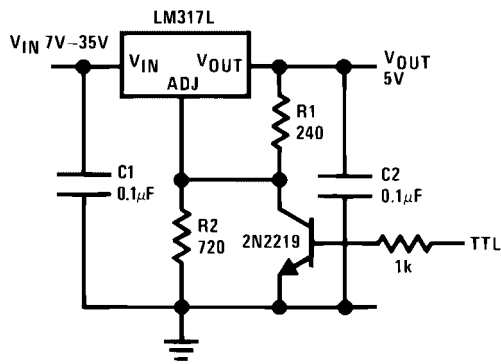

\*Minimum output ≈ 1.2V

Current Limited 6V Charger

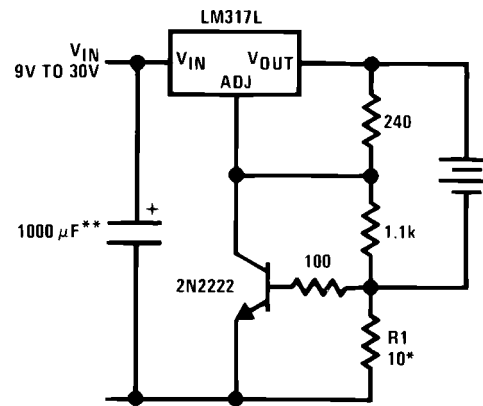

\*Sets peak current,  $I_{PEAK} = 0.6V/R1$

\*\*1000μF is recommended to filter out any input transients.

Typical Applications (Continued)

Short Circuit Protected 80V Supply

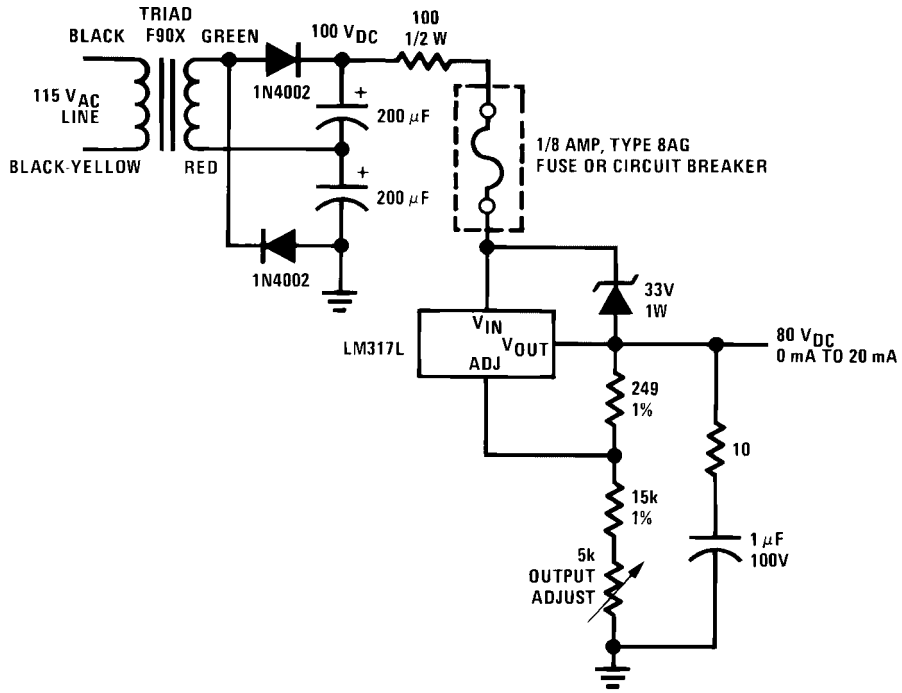

DS009064-28

Basic High Voltage Regulator

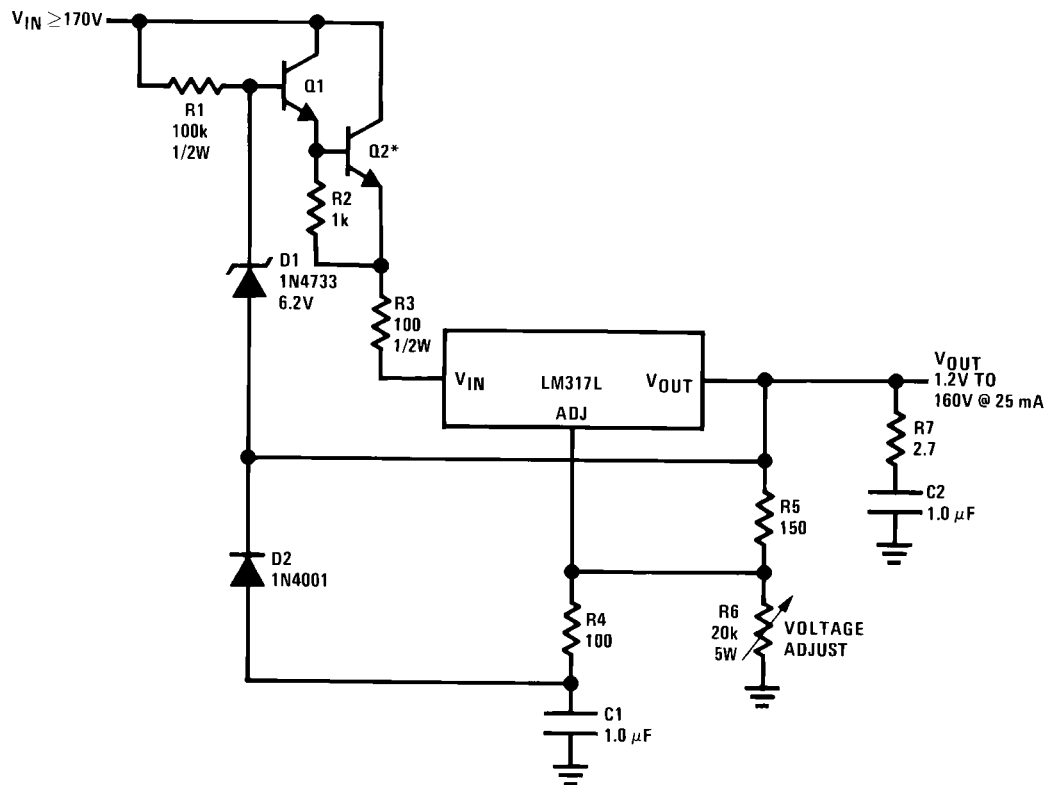

DS009064-29

Q1, Q2: NSD134 or similar  
 C1, C2: 1µF, 200V mylar\*\*  
 \*Heat sink

Typical Applications (Continued)

Precision High Voltage Regulator

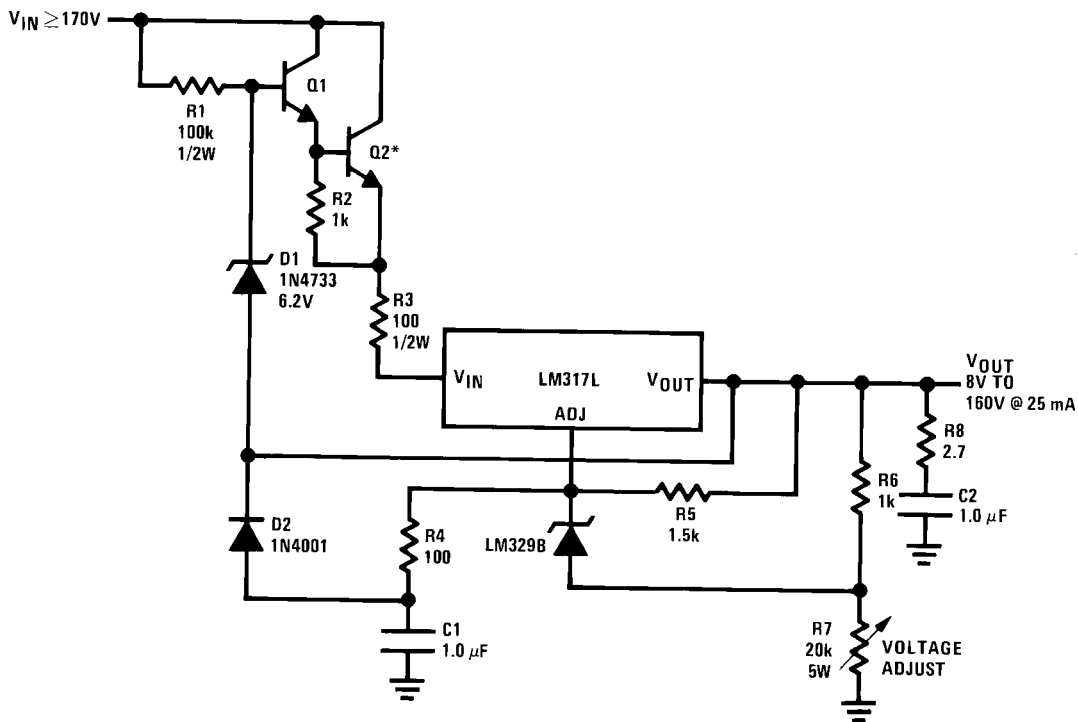

DS009064-30

Q1, Q2: NSD134 or similar  
C1, C2: 1µF, 200V mylar\*\*

\*Heat sink

\*\*Mylar is a registered trademark of DuPont Co.

Tracking Regulator

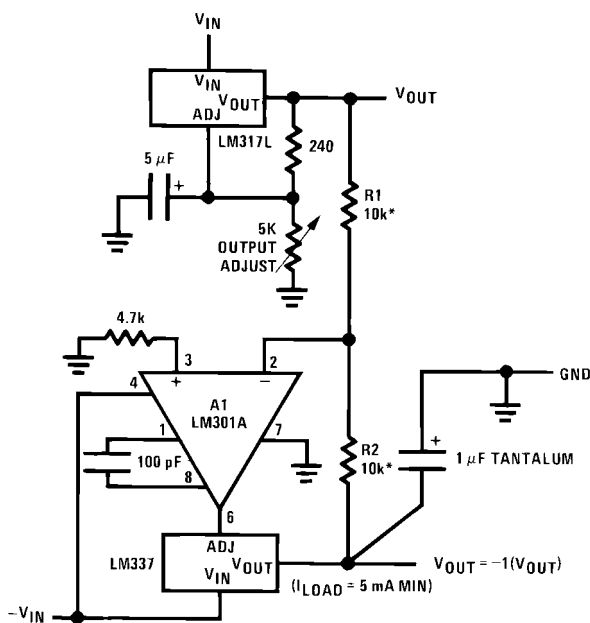

DS009064-31

A1 = LM301A, LM307, or LF13741 only

R1, R2 = matched resistors with good TC tracking

Regulator With Trimmable Output Voltage

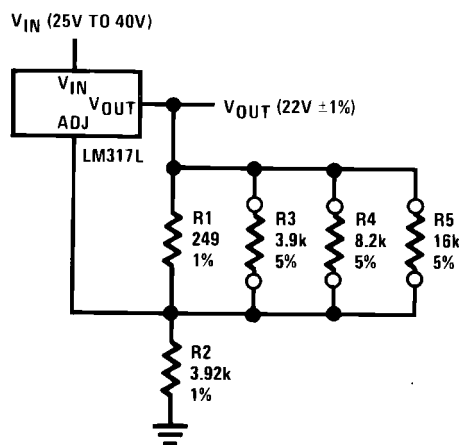

DS009064-32

Trim Procedure:

- If  $V_{OUT}$  is 23.08V or higher, cut out R3 (if lower, don't cut it out).
- Then if  $V_{OUT}$  is 22.47V or higher, cut out R4 (if lower, don't).
- Then if  $V_{OUT}$  is 22.16V or higher, cut out R5 (if lower, don't).

This will trim the output to well within  $\pm 1\%$  of  $22.00 V_{DC}$ , without any of the expense or uncertainty of a trim pot (see LB-46). Of course, this technique can be used at any output voltage level.



**Physical Dimensions** inches (millimeters) unless otherwise noted

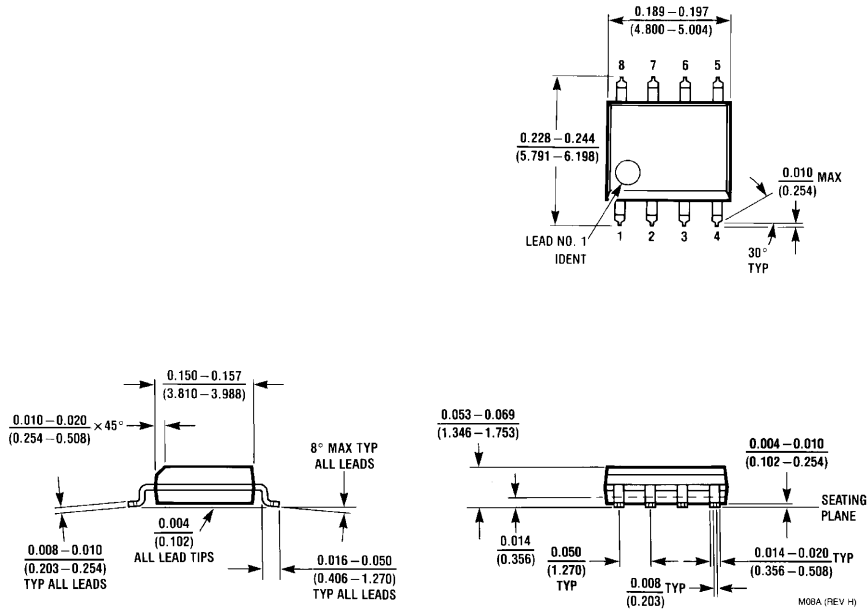

**SO-8 Molded Package**  
NS Package Number M08A

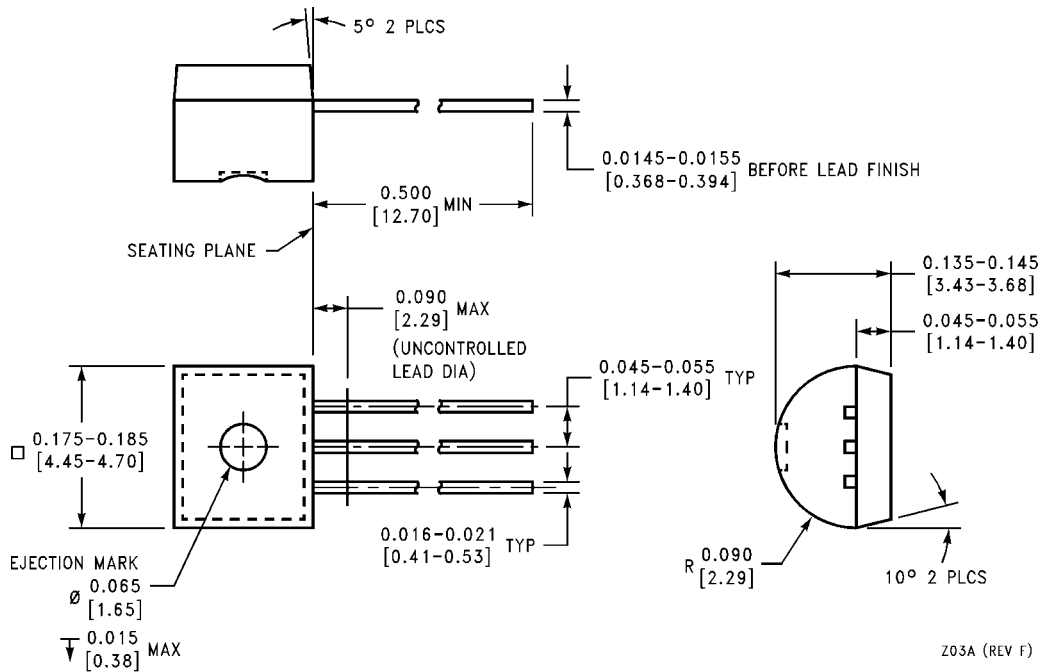

**TO-92 Plastic Package (Z)**  
NS Package Number Z03A

**Physical Dimensions** inches (millimeters) unless otherwise noted (Continued)

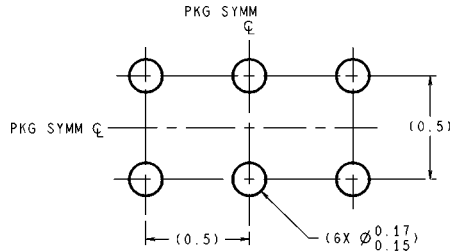

DIMENSIONS ARE IN MILLIMETERS

**LAND PATTERN RECOMMENDATION**

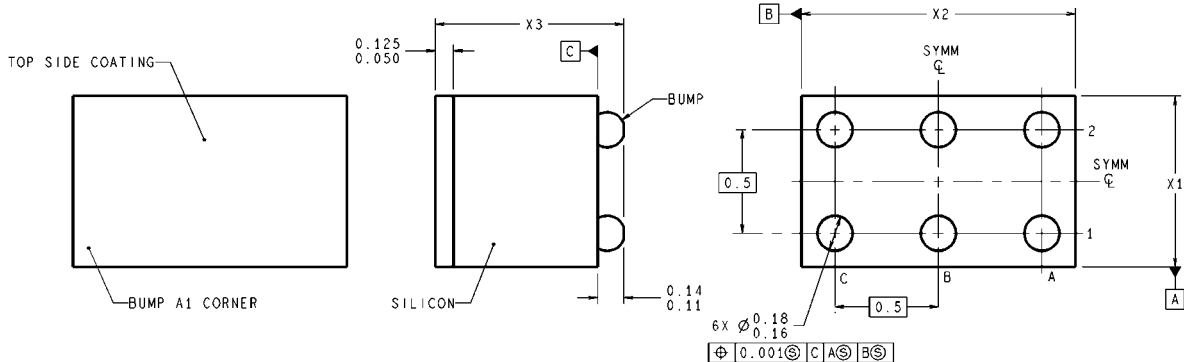

BPA06XXX (Rev C)

NOTE: UNLESS OTHERWISE SPECIFIED.

1. EPOXY COATING
2. 63Sn/37Pb EUTECTIC BUMP.
3. RECOMMEND NON-SOLDER MASK DEFINED LANDING PAD.
4. PIN A1 IS ESTABLISHED BY LOWER LEFT CORNER WITH RESPECT TO TEXT ORIENTATION PINS ARE NUMBERED COUNTERCLOCKWISE.
5. XXX IN DRAWING NUMBER REPRESENTS PACKAGE SIZE VARIATION WHERE  $X_1$  IS PACKAGE WIDTH,  $X_2$  IS PACKAGE LENGTH AND  $X_3$  IS PACKAGE HEIGHT.
6. REFERENCE JEDEC REGISTRATION MO-211, VARIATION BC.

**6-Bump micro SMD**  
**NS Package Number BPA06HPB**  
 $X_1 = 0.955$   $X_2 = 1.615$   $X_3 = 0.850$

**LIFE SUPPORT POLICY**

NATIONAL'S PRODUCTS ARE NOT AUTHORIZED FOR USE AS CRITICAL COMPONENTS IN LIFE SUPPORT DEVICES OR SYSTEMS WITHOUT THE EXPRESS WRITTEN APPROVAL OF THE PRESIDENT AND GENERAL COUNSEL OF NATIONAL SEMICONDUCTOR CORPORATION. As used herein:

1. Life support devices or systems are devices or systems which, (a) are intended for surgical implant into the body, or (b) support or sustain life, and whose failure to perform when properly used in accordance with instructions for use provided in the labeling, can be reasonably expected to result in a significant injury to the user.
2. A critical component is any component of a life support device or system whose failure to perform can be reasonably expected to cause the failure of the life support device or system, or to affect its safety or effectiveness.



**National Semiconductor Corporation**  
 Americas  
 Email: support@nsc.com

www.national.com

**National Semiconductor Europe**  
 Fax: +49 (0) 180-530 85 86  
 Email: europe.support@nsc.com  
 Deutsch Tel: +49 (0) 69 9508 6208  
 English Tel: +44 (0) 870 24 0 2171  
 Français Tel: +33 (0) 1 41 91 8790

**National Semiconductor Asia Pacific Customer Response Group**  
 Tel: 65-2544466  
 Fax: 65-2504466  
 Email: ap.support@nsc.com

**National Semiconductor Japan Ltd.**  
 Tel: 81-3-5639-7560  
 Fax: 81-3-5639-7507