HA12207NT

Audio Signal Processor for Cassette Deck

HITACHI

ADE-207-197B (Z)

3rd Edition
Jun. 1999

Description

HA12207NT is silicon monolithic bipolar IC providing PB equalizer, REC equalizer system and each electronic control switch in one chip.

Functions

- PB equalizer × 2 channel
- REC equalizer × 2 channel
- Each electronic control switch to change REC/PB etc.
- REC MUTE
- REC head return switch

Features

- REC equalizer is very small number of external parts, built-in 2 types of frequency characteristics.
- PB equalizer circuit built-in.
- REC /PB of high speed mode are possible with TYPE 1(Normal tape).
- Controllable from direct micro-computer output.
- Available to reduce substrate-area because of high integration and small external parts.
- As the pins arrangement resembles HA12185NT, it can design the board that is replaced with HA12185NT.

HA12207NT

Pin Description, Equivalent Circuit ($V_{CC} = 10.5V$, $V_{ref} = 5.6V$, $T_a = 25^\circ C$, No signal, The value in the table show typical value.)

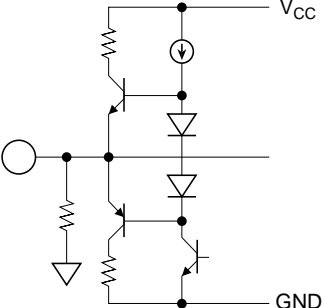
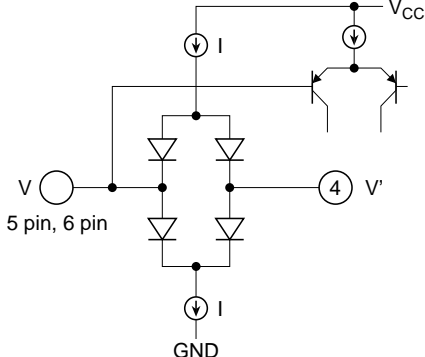
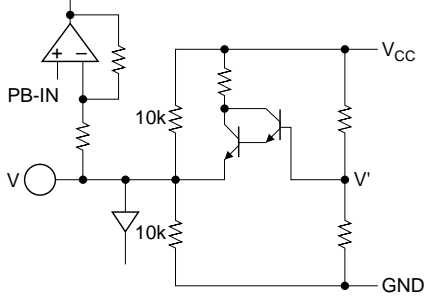
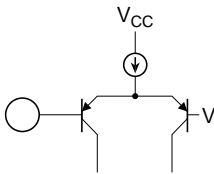
Pin No.	Pin Name	Note	Equivalent Circuit	Pin Description
1	V_{CC}	$V = V_{CC}$		V_{CC} pin
2	RECOUT (L)	$V = V_{ref}$		REC-EQ output
3	RECOUT (R)			
4	REC-RETURN	$V = V_{ref}$ $V' = V_{ref}$		REC return
5	PB-IN B (L)			PB B Deck input
6	PB-IN B (R)			
7	VREF	$V = V_{ref}$ $V' = V_{CC} / 2$		Reference
8	PB-IN A (L)	$V = V_{ref}$		PB A deck input
9	PB-IN A (R)			

Pin Description, Equivalent Circuit ($V_{CC} = 10.5V$, $V_{ref} = 5.6V$, $T_a = 25^\circ C$, No signal, The value in the table show typical value.)

Pin No.	Pin Name	Note	Equivalent Circuit	Pin Description
10	PB-NF (L)	PB-IN = V_{ref}		PB EQ feed back
11	PB-NF (R)			
12	PB-EQ (L)	PBOUT = V_{ref}		NAB output
13	PB-EQ (R)			
20	REC IN (R)	$V = V_{ref}$		REC-EQ input
21	REC IN (L)			
14	PBOUT (R)	$V = V_{ref}$		PB output
15	PBOUT (L)			

HA12207NT

Pin Description, Equivalent Circuit ($V_{CC} = 10.5V$, $V_{ref} = 5.6V$, $T_a = 25^\circ C$, No signal, The value in the table show typical value.)

Pin No.	Pin Name	Note	Equivalent Circuit	Pin Description
16	$\overline{A/B}$	$I = 20\mu A$		Mode control input
17	HSP			
18	\overline{MUTE}			
19	IREF	$V = 1.9V$		Equalizer reference current input
22	GND			GND pin

Block Diagram

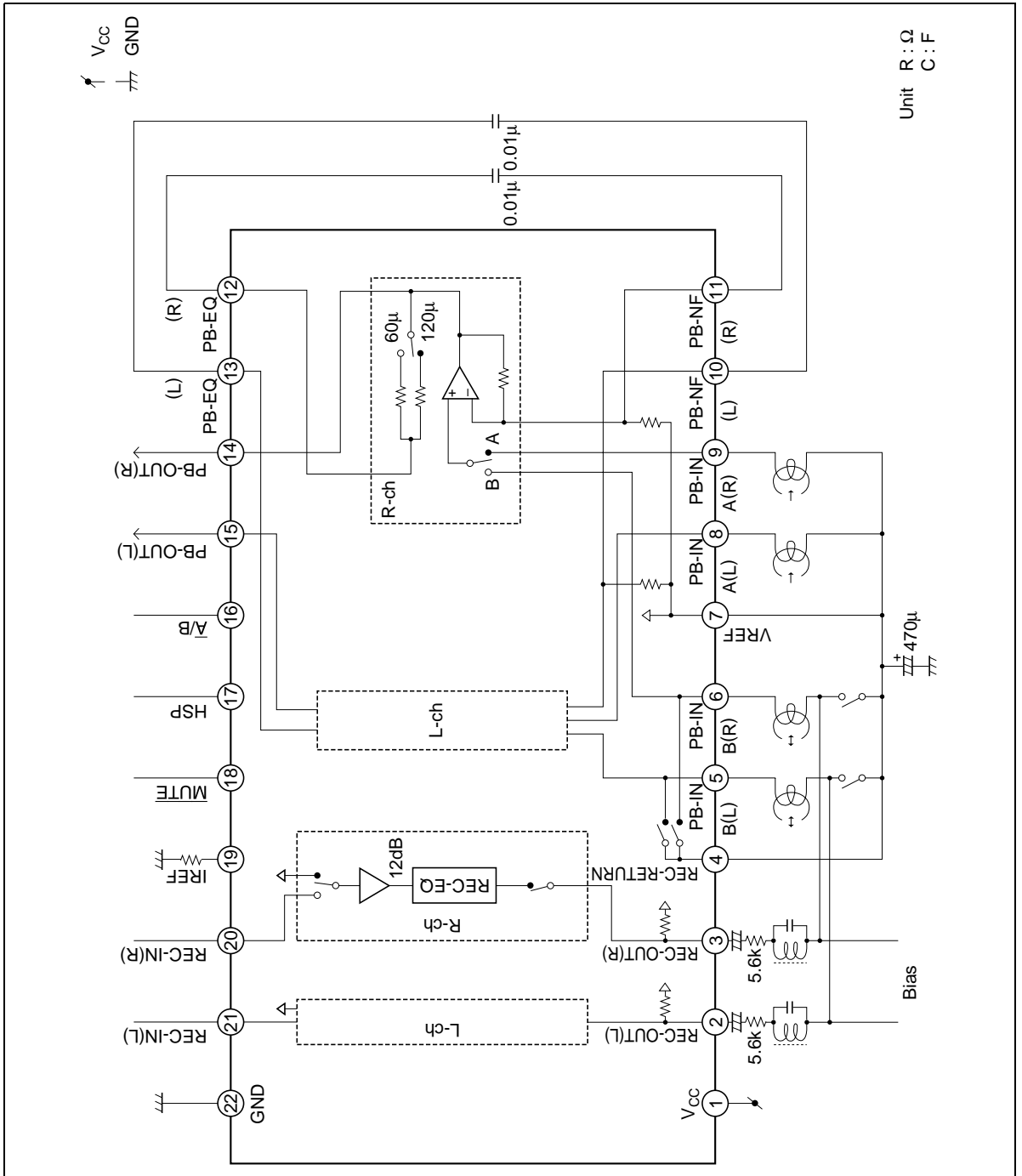

HA12207NT

Parallel Data Format

Pin No.	Pin Name	L	H
17	HSP	Normal *	Hi speed
16	$\overline{A/B}$	Ain active *	Bin active
		Return SW ON *	Return SW OFF
		REC OUT active *	REC OUT HIZ
18	\overline{MUTE}	MUTE ON *	MUTE OFF

Note: Unforced pin state

Functional Description

Power Supply Range

HA12207NT is designed to operate on single supply, shown by table 1.

Table 1 Supply Voltage

Item	Power Supply Range
Single Supply	9.5V to 15.0V

Reference Voltage

As AC reference (V_{ref}) of this IC has not a current drivability, V_{ref} fluctuates by A/B switching of PB-EQ.

Provided it causes you anxiety, please supply 7 pin with approximate $1/2 V_{CC}$ voltage.

For example, a suitable circuit is shown by figure 1.

This IC has a capacitor charger for the V_{ref} , indicated to the pin interface circuit figure.

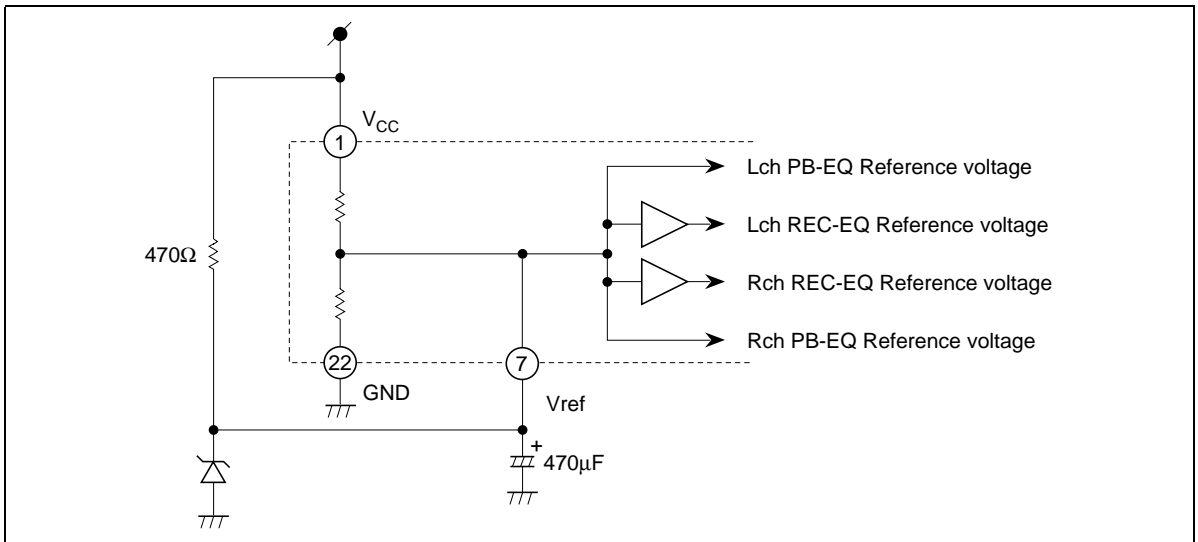

Figure 1 Reference Voltage Circuit

HA12207NT

Operating Mode Control

HA12207NT provides fully electronic switching circuits. And each operating mode control is controlled by parallel data (DC voltage).

Table 2 shows the control voltage of each control input pin.

Table 2 Control Voltage (Vth)

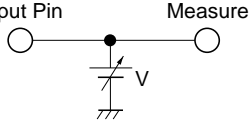
Pin No.	Lo	Hi	Unit	Test Condition
16, 17	0.0 to 1.0	4.0 to V_{CC}	V	Input Pin 
18	0.0 to 3.0	4.0 to V_{CC}	V	

- Note:
- Each pin is pulled down with 100kΩ internal resistor. 16 to 18 pins are low-level when each pin is open.
 - Over shoot level and under shoot level of input signal must be the standardized.
(High: Less than V_{CC} , Low: More than $-0.2V$)

Block Diagram

Figure 2 shows the block diagram.

As this IC is built-in REC return switch, the configuration system can be simple system using a few external component and the REC/PB head.

As this IC adopted Hi-z SW of REC-EQ output and the input mute system, it realizes REC mute attenuation and pop-noise reduction securing in REC mute.

About these logics, please look at the Parallel Data Format.

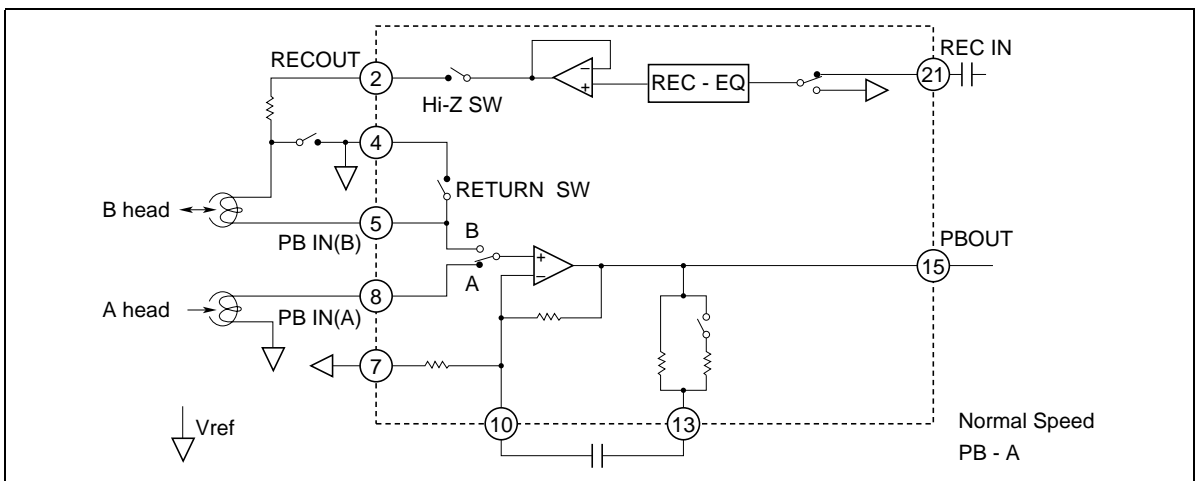

Figure 2 Block Diagram (Lch)

Level Block Diagram

The gain establishment of PB-EQ considers PB output level {(external AMP+PB AMP)=300mV(Dolby Level)} like figure 3 as the target.

Regarding REC-EQ adjust the gain in front of input to this IC.

The level diagram of 1kHz is shown figure 4. (Normal speed)

Similarly to PB, it consider Dolby level as a standard. And R1 needs the value more than 5.6kΩ.

Because mode establishment resistances are built-in, REC-EQ frequency characteristics are respectively fixed value.

In case the change of the frequency characteristics are necessary, please inquire the responsible agent because the adjustment of resistors is necessary.

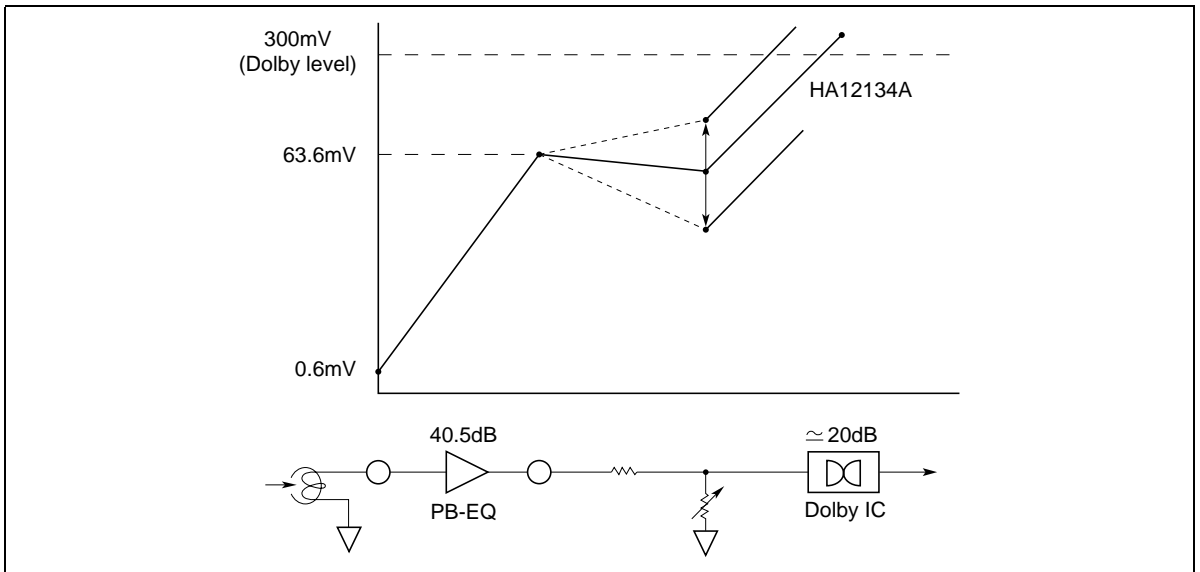

Figure 3 PB Level Block Diagram (Normal Speed, 1kHz)

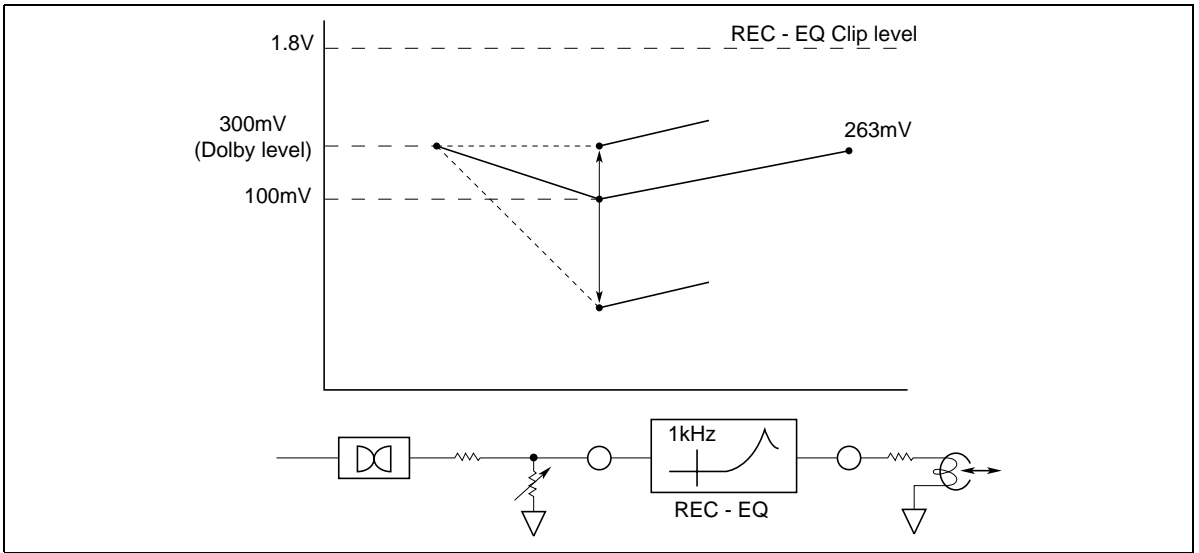

Figure 4 REC Level Block Diagram (Normal Speed, 1kHz)

Absolute Maximum Rating (Ta = 25°C)

Item	Symbol	Rating	Unit	Note
Max supply voltage	V _{cc} max	16	V	
Power dissipation	Pd	500	mW	Ta ≤ 75°C
Operating temperature	Topr	-40 to +75	°C	
Storage temperature	Tstg	-55 to +125	°C	
Operating voltage	Vopr	9.5 to 15	V	

Note: HA12207NT operates on single supply voltage.

Electrical Characteristics (Ta = 25°C, V_{CC} = 10.5V, V_{ref} = 5.25V)

Item	Symbol	Min	Typ	Max	Unit	Test Condition				Application Terminal					
						IC Condition				Input Output					
						A/B	HSP	MUTE	fin (Hz)	Vin (mVrms)	Other	R	L	R	L
Quiescent current	I _Q	16.0	22.4	32.0	mA	A	Normal	MUTE	—	No signal	—	—	—	1	
Logical threshold	V _{IL} (1)	-0.2	—	1.0	V	—	—	—	—	—	—	—	—	16, 17	
	V _{IL} (2)	-0.2	—	3.0	V	—	—	—	—	—	—	—	—	18	
	V _{IH}	4.0	—	V _{CC}	V	—	—	—	—	—	—	—	—	16, 17, 18	
PB-REC crosstalk	CT PB/REC(1)	50	60	—	dB	A/B	Normal	Mute	1k	*1	REC-EQ → PB-EQ	20	21	14	15
	CT PB/REC(2)	60	70	—	dB	A	Normal	Mute	1k	*1	PB-EQ → REC-EQ	9	8	3	2
PB-EQ gain	G _V PB(1)	37.5	40.5	43.5	dB	A/B	Normal	Mute	1k	0.6	—	9/6	8/5	14	15
	G _V PB(2)	33.2	36.2	39.2	dB	A/B	Normal	Mute	10k	0.6	—	9/6	8/5	14	15
	G _V PB(3)	27.5	30.5	33.5	dB	A/B	High	Mute	20k	0.6	—	9/6	8/5	14	15
PB-EQ maximum output	V _{omax} PB	0.3	0.6	—	Vrms	A/B	Normal	Mute	1k	—	THD=1%*2	9/6	8/5	14	15
PB-EQ THD	THD PB	—	0.1	0.5	%	A/B	Normal	Mute	1k	0.6	—	9/6	8/5	14	15
PB-EQ noise voltage	V _N PB	—	90	180	μVrms	A/B	Normal	Mute	—	—	Rg=820Ω, DIN-AUDIO	9/6	8/5	14	15
PB-EQ channel separation	CT R/L(1)	50	60	—	dB	A/B	Normal	Mute	1k	*1	—	8/5	9/6	14	15
PB-EQ crosstalk	CT A/B	60	70	—	dB	A	Normal	Mute	1k	*1	—	6	5	14	15
						B						9	8		

Note: 1. Large level without clipping
 2. V_{CC}=9.5V, V_{ref}=4.75V

Electrical Characteristics (Ta = 25°C, V_{CC} = 10.5V, V_{ref} = 5.25V) (cont)

Item	Symbol	Test Condition						Application Terminal							
		IC Condition						Input			Output				
		A/B	HSP	MUTE	fin (Hz)	Vin (mVrms)	Other	R	L	R	L	R	L	COM	
	Min	Typ	Max	Unit											
REC-EQ frequency response Normal speed	G _V REC-NN1	6.9	8.4	9.9	dB	A	Normal	Mute OFF	1k	10		20	21	3	2
	G _V REC-NN2	10.3	12.3	14.3	dB	A	Normal	Mute OFF	5k	10		20	21	3	2
	G _V REC-NN3	18.7	21.7	24.7	dB	A	Normal	Mute OFF	10k	10		20	21	3	2
REC-EQ frequency response High speed	G _V REC-HN1	7.6	9.1	10.6	dB	A	High	Mute OFF	2k	10		20	21	3	2
	G _V REC-HN2	12.1	14.1	16.1	dB	A	High	Mute OFF	10k	10		20	21	3	2
	G _V REC-HN3	19.9	22.9	25.9	dB	A	High	Mute OFF	20k	10		20	21	3	2
REC-EQ channel separation	CT R/L(2)	50	60	—	dB	A	Normal	Mute OFF	1k	*3		20	21	3	2
REC-MUTE attenuation	R-MUTE ATT	70	80	—	%	A	Normal	Mute	1k	*3		20	21	3	2
REC-EQ maximum output	V _{omax} REC	1.2	1.8	—	V _{rms}	A	Normal	Mute OFF	1k	—	THD=1%*4	20	21	3	2
REC-EQ THD	THD REC	—	0.35	0.7	%	A	Normal	Mute OFF	1k	100		20	21	3	2
REC-EQ S/N	S/N REC	52	56	—	dB	A	Normal	Mute OFF	—	—	Rg=5.1kΩ, A-WTG	20	21	3	2

Note: 3. Large level without clipping

4. V_{CC}=9.5V, V_{ref}=4.75V

Test Circuit

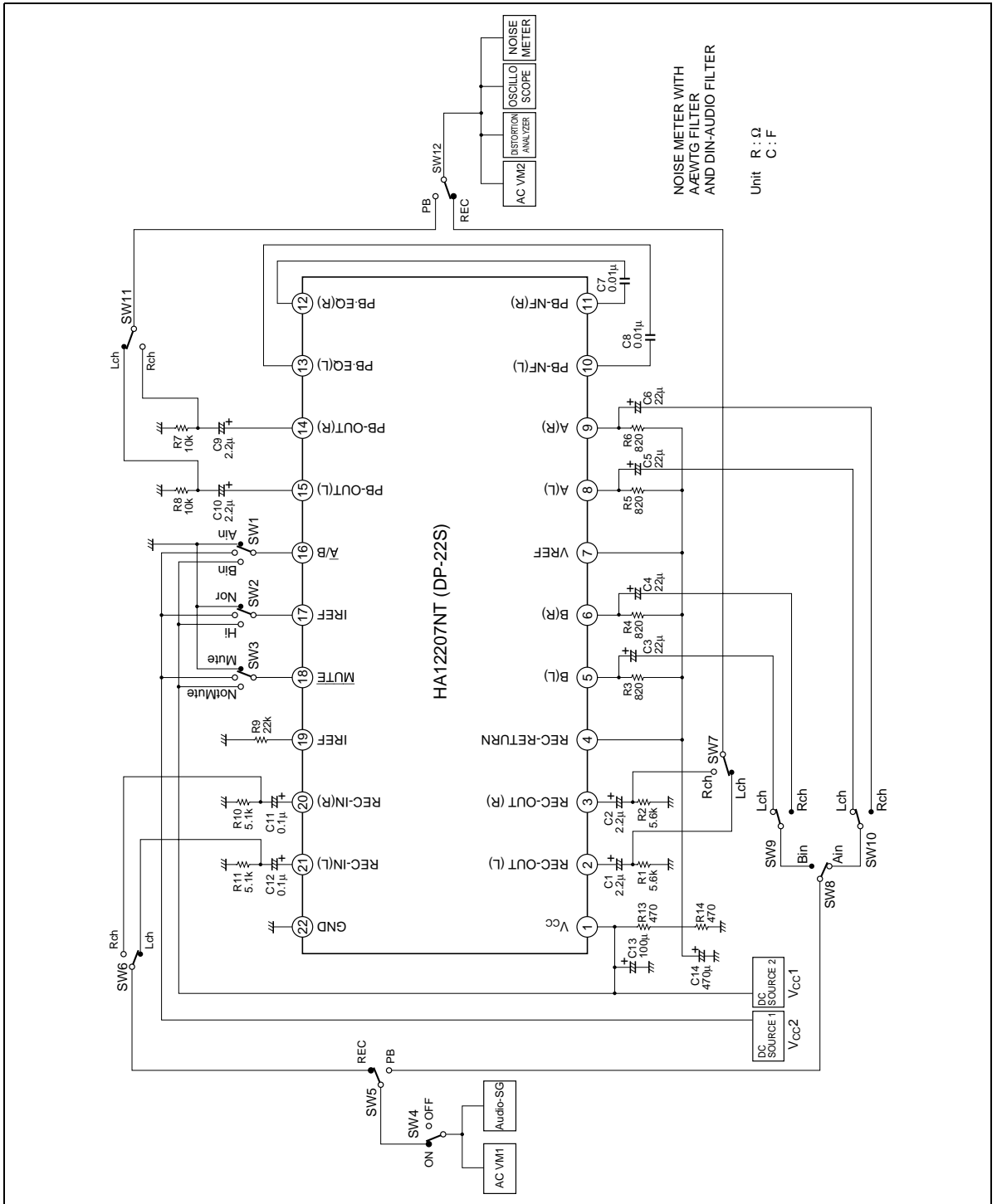

Characteristic Curves

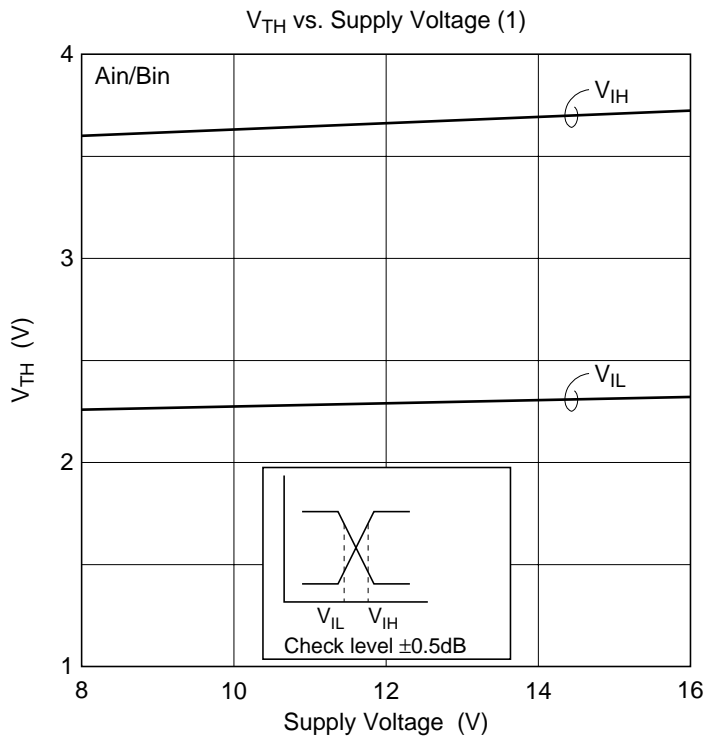
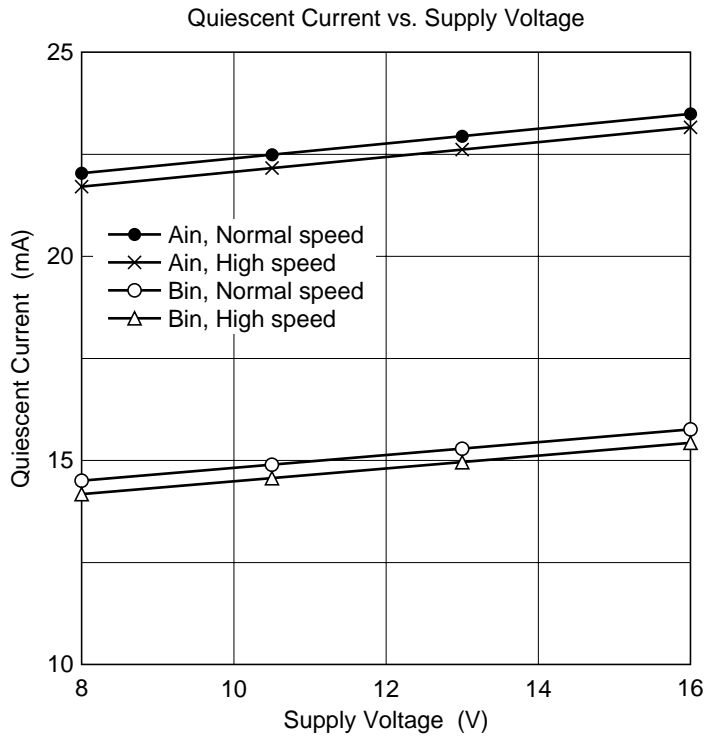

V_{TH} vs. Supply Voltage (2)

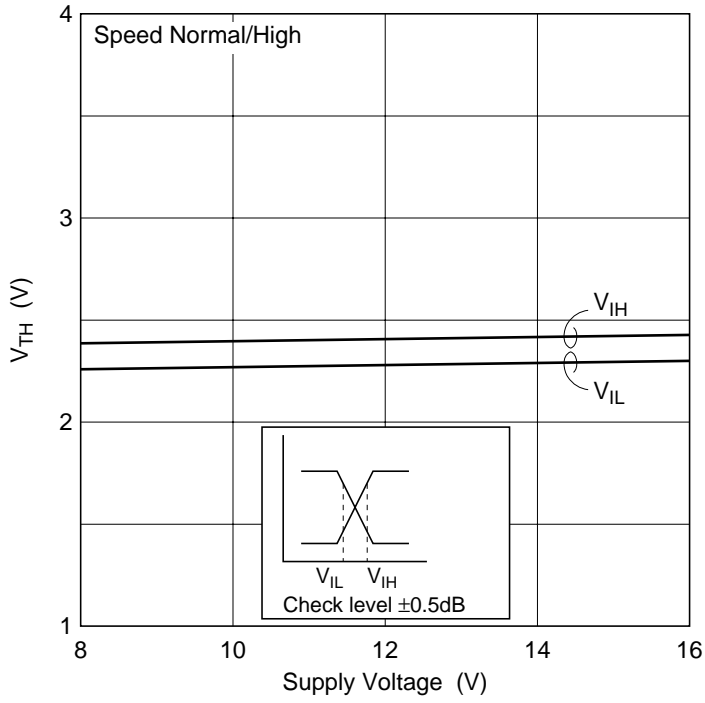

V_{TH} vs. Supply Voltage (3)

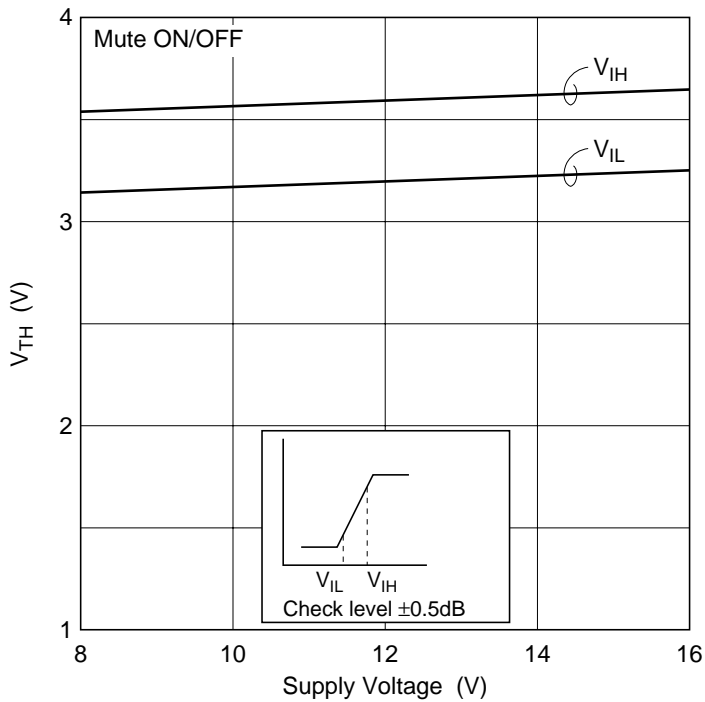

Altered Reference Voltage vs. External Impedance

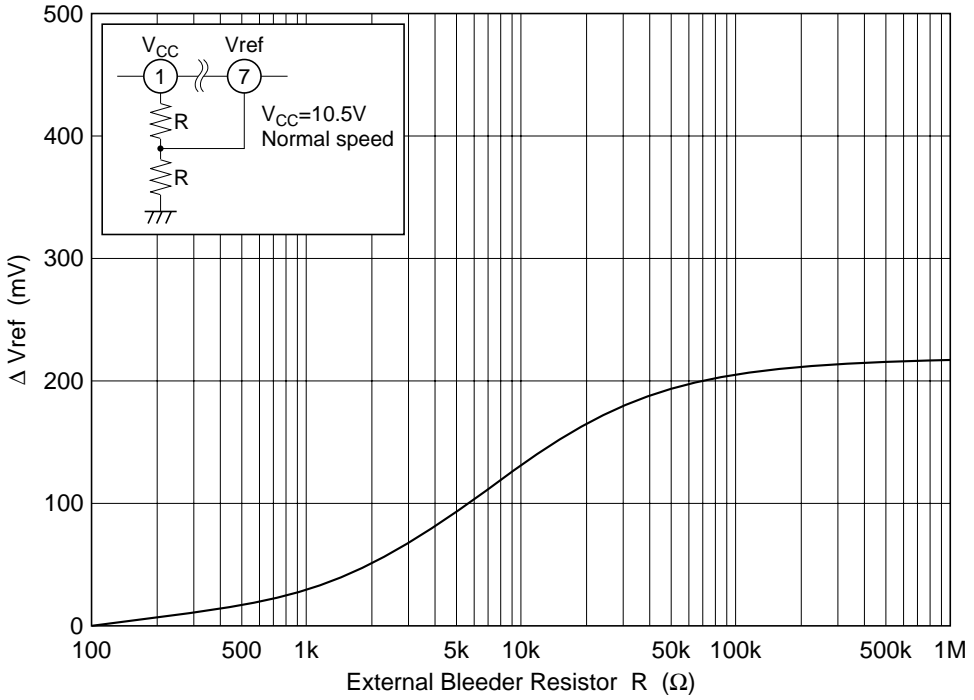

REC-EQ \rightarrow PB-EQ Mode Crosstalk vs. Frequency

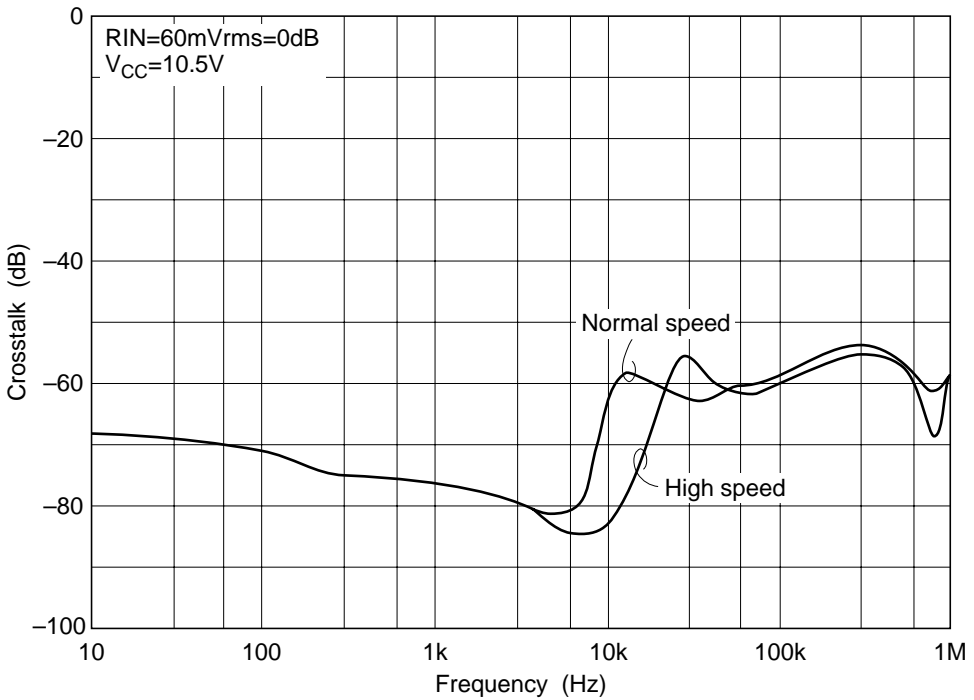

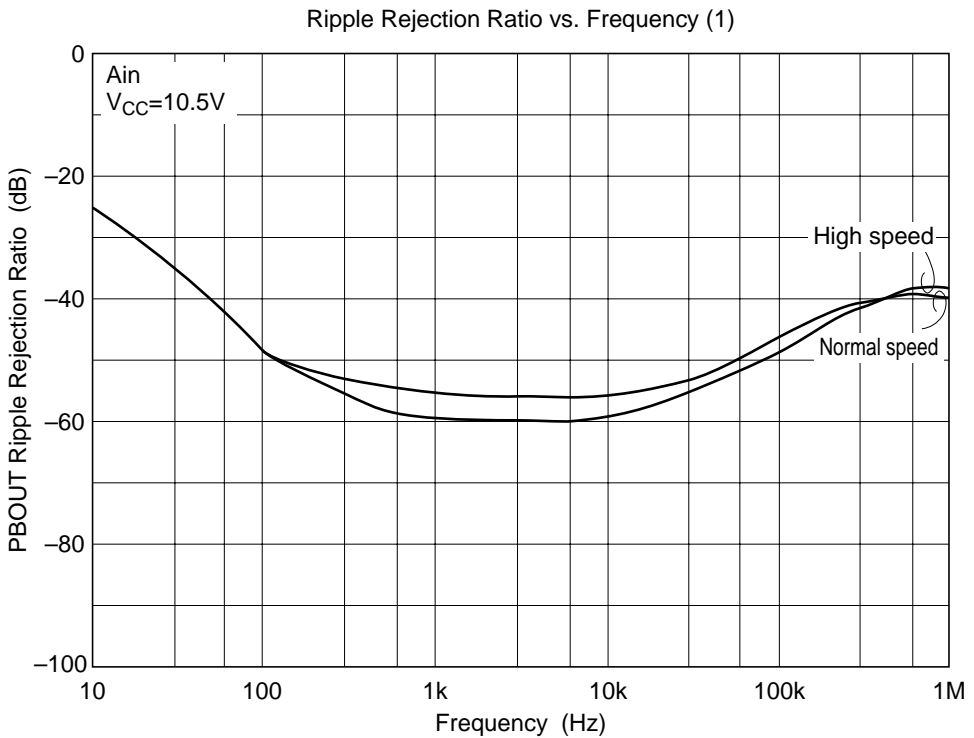
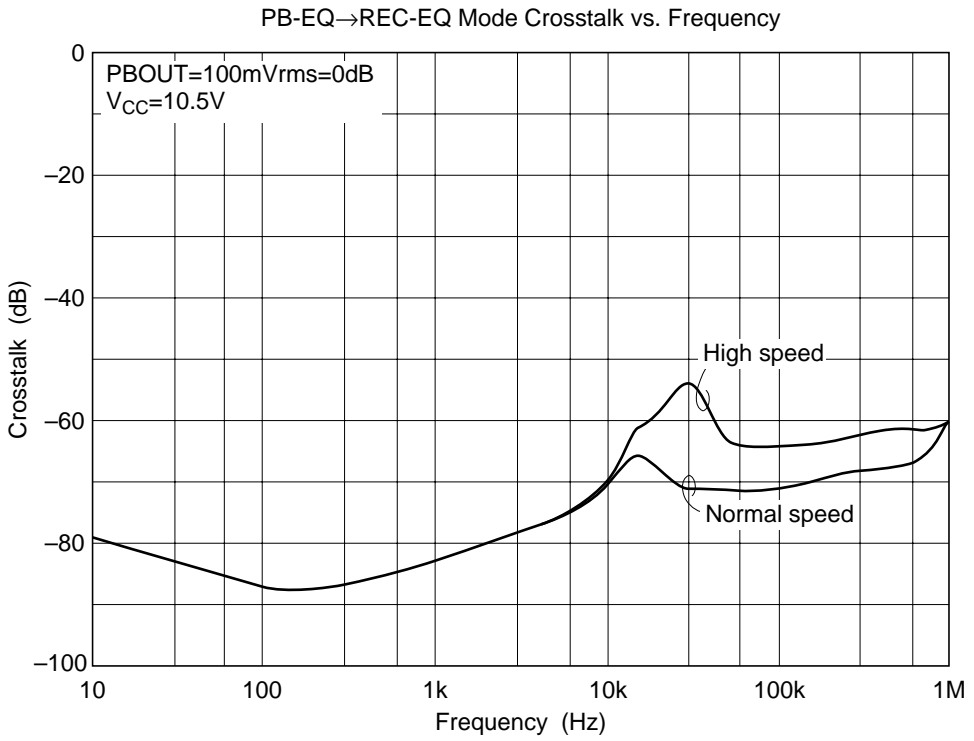

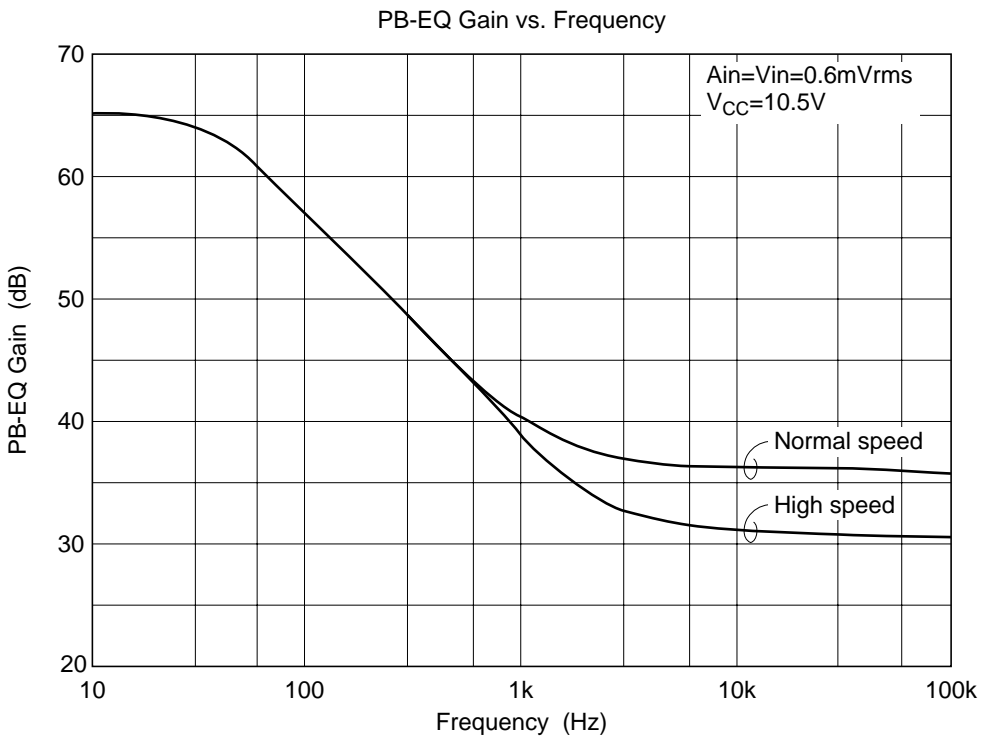
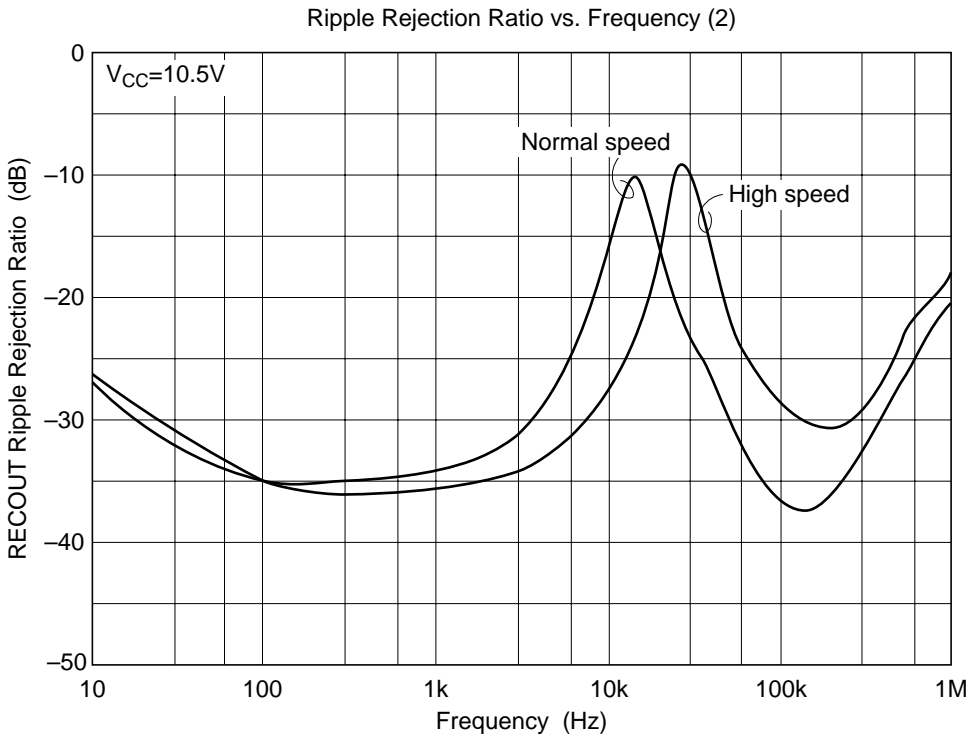

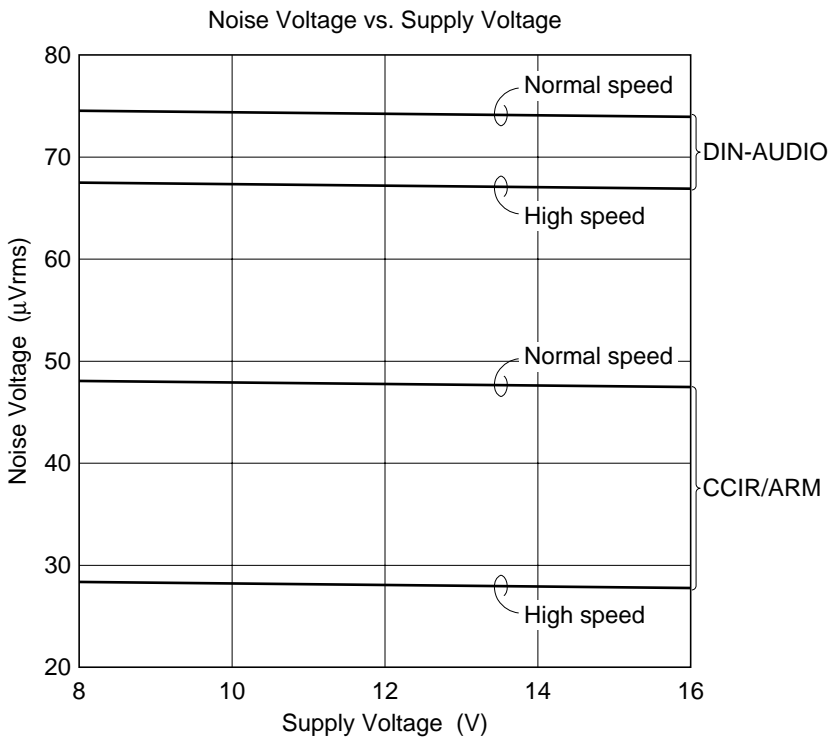
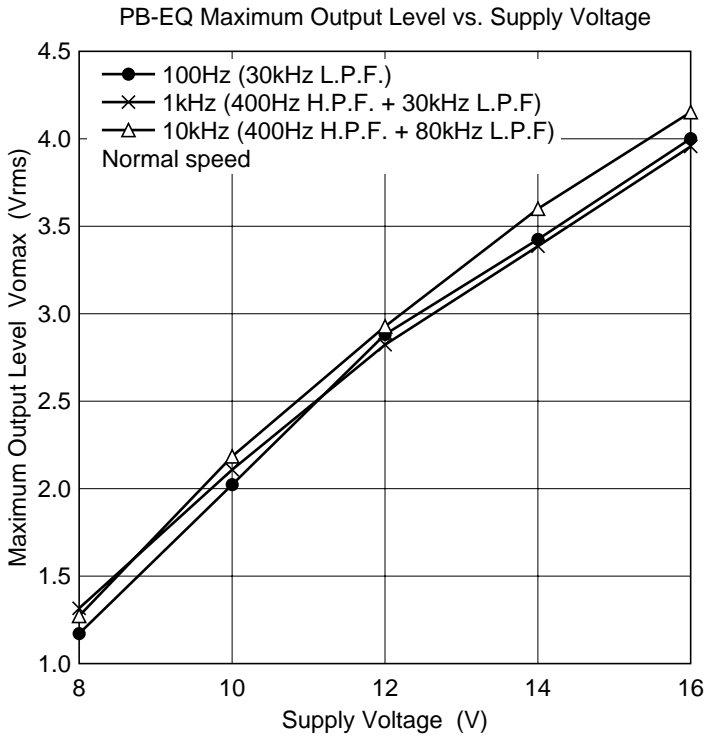

PB-EQ Total Harmonic Distortion vs. Output Level

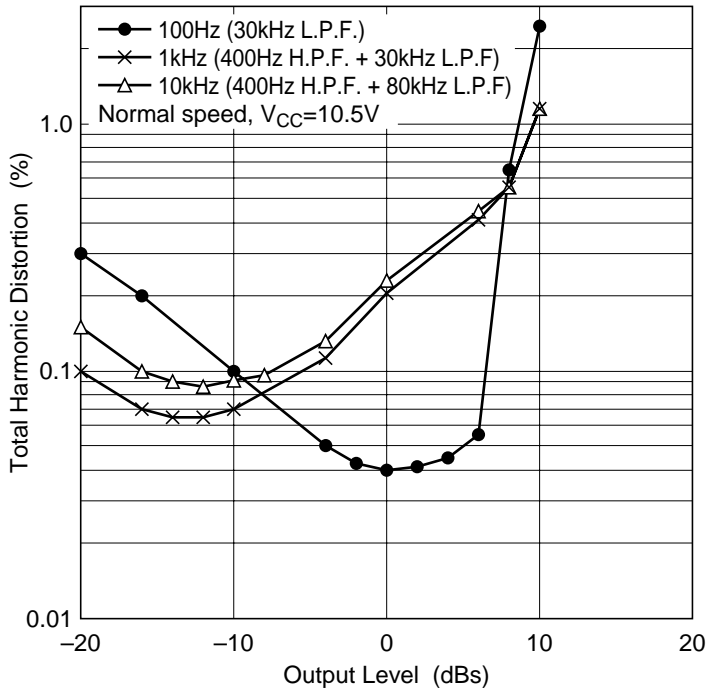

PB-EQ Crosstalk (Ain→Bin) vs. Frequency

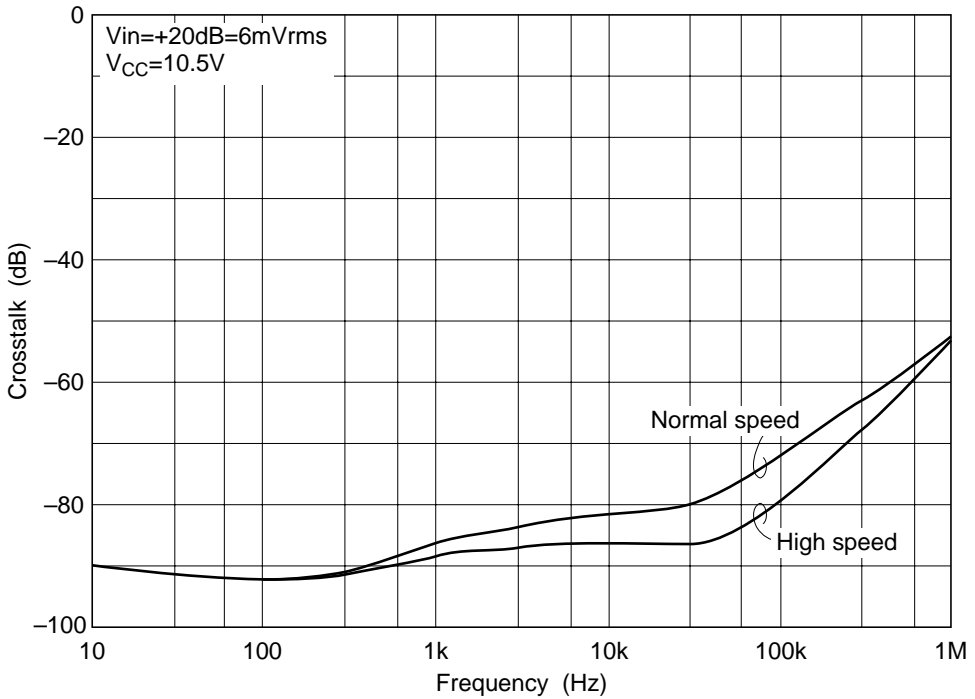

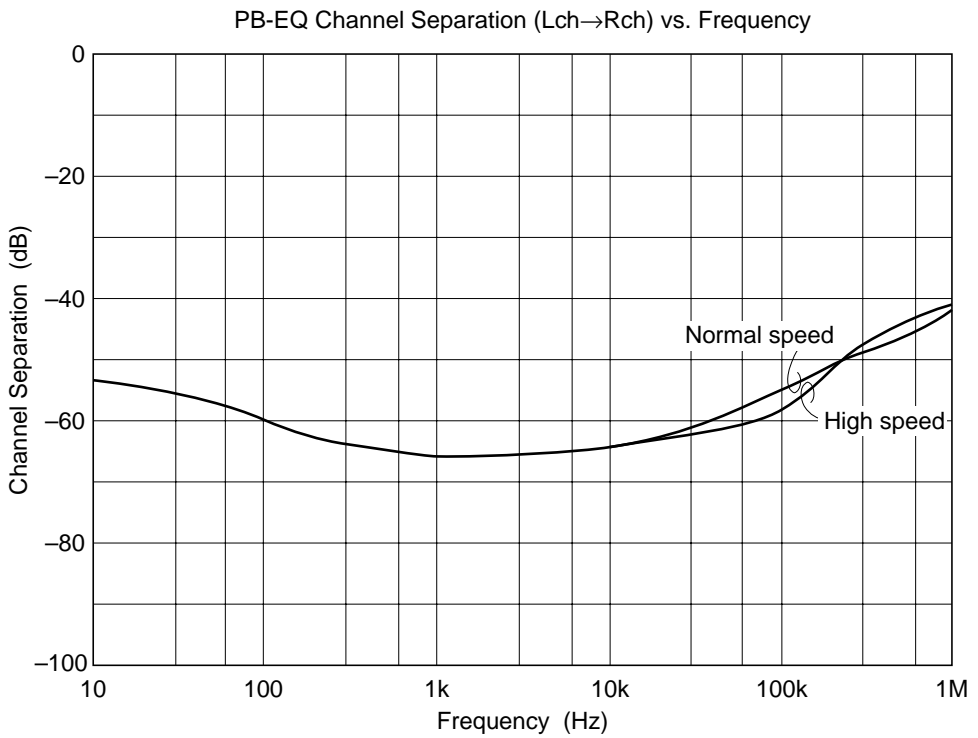
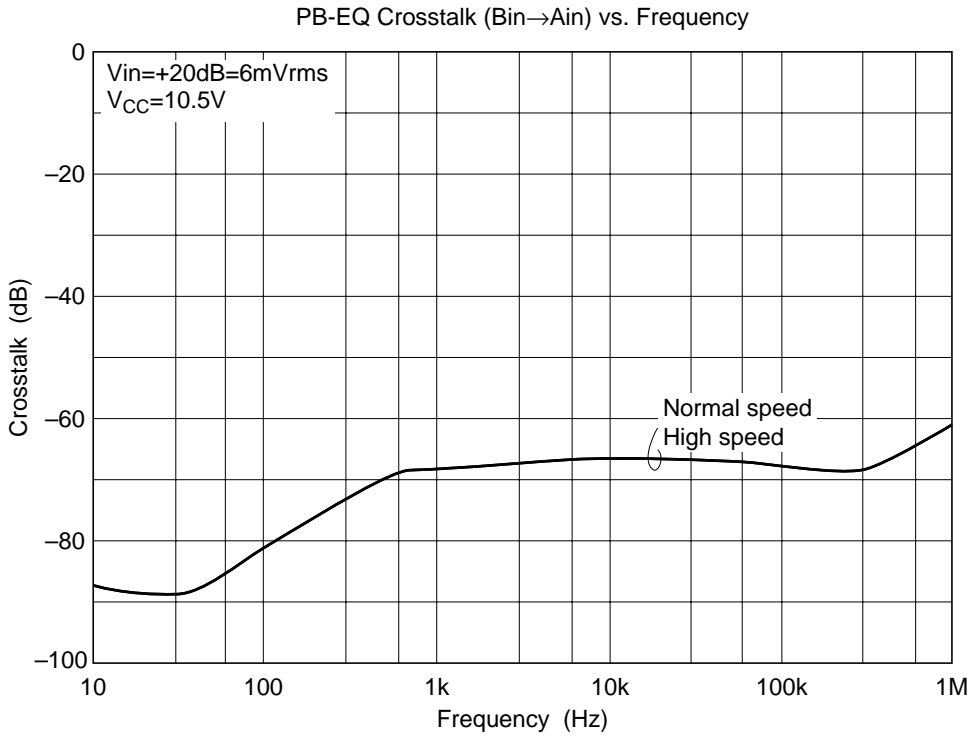

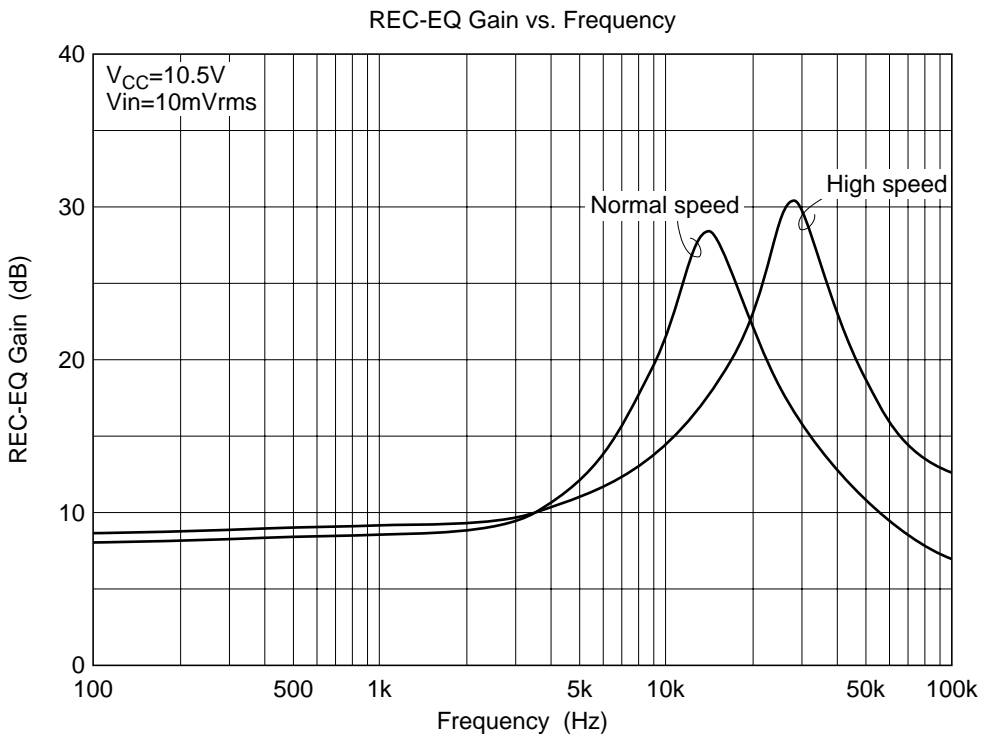
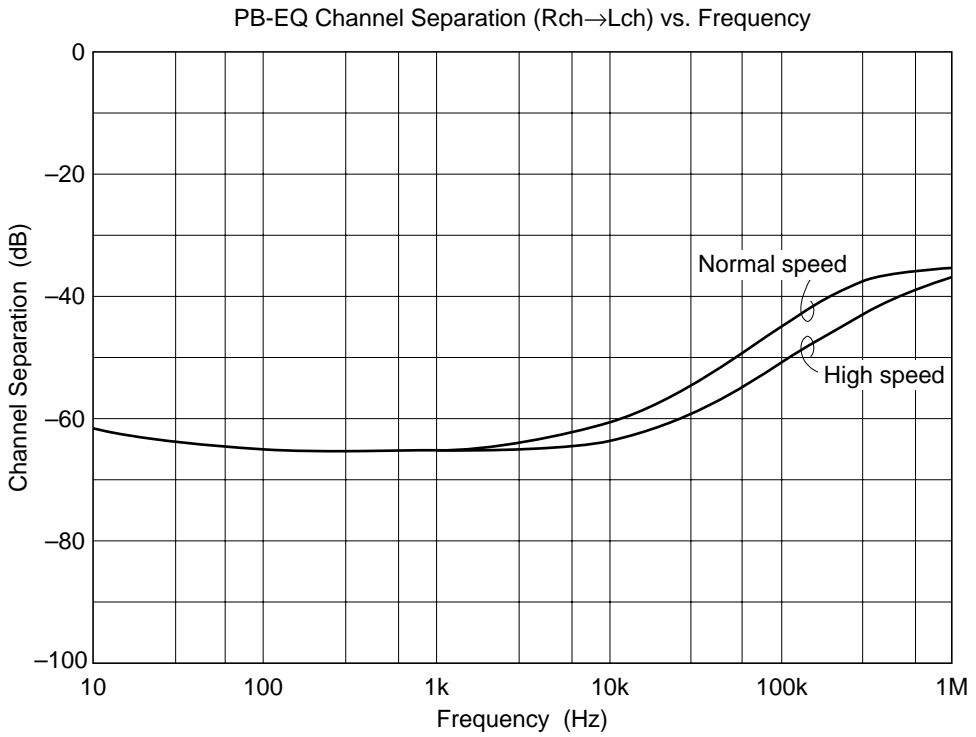

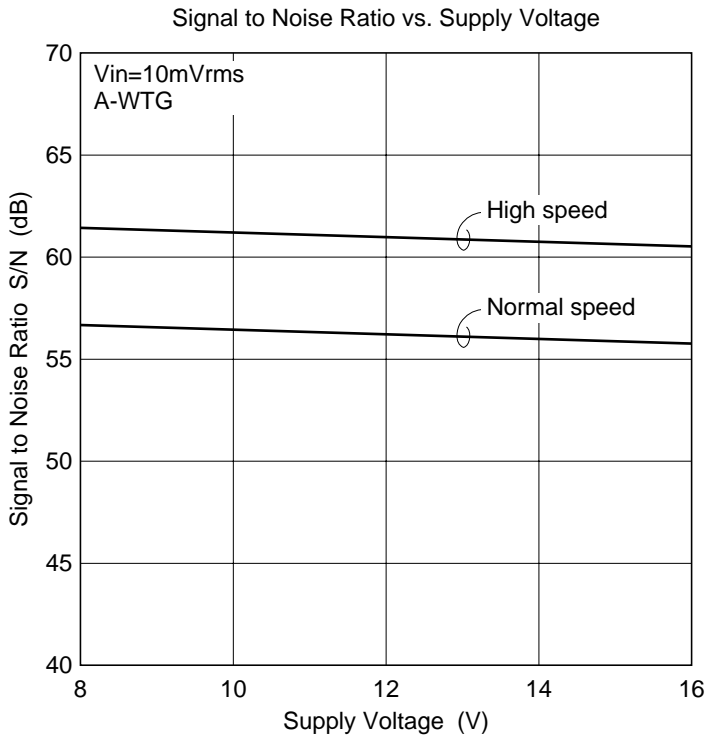
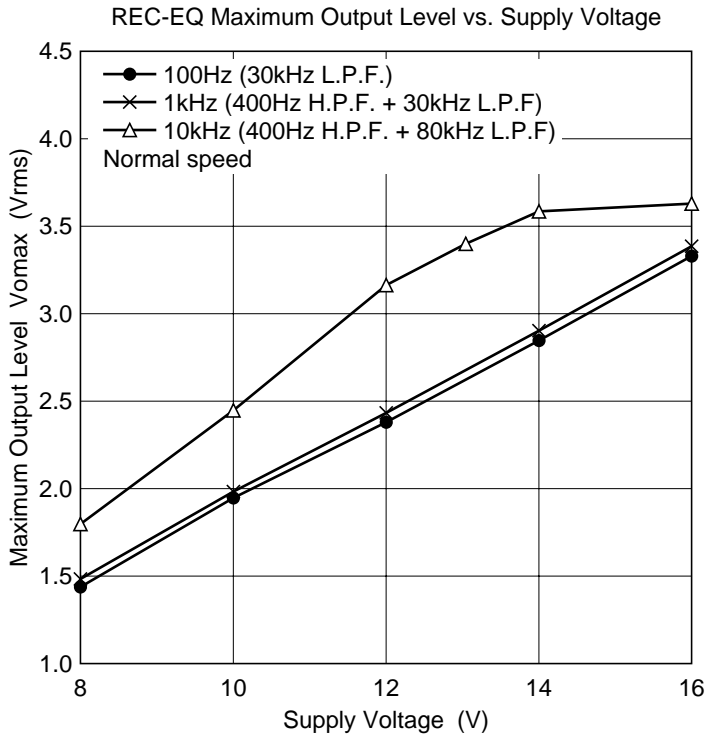

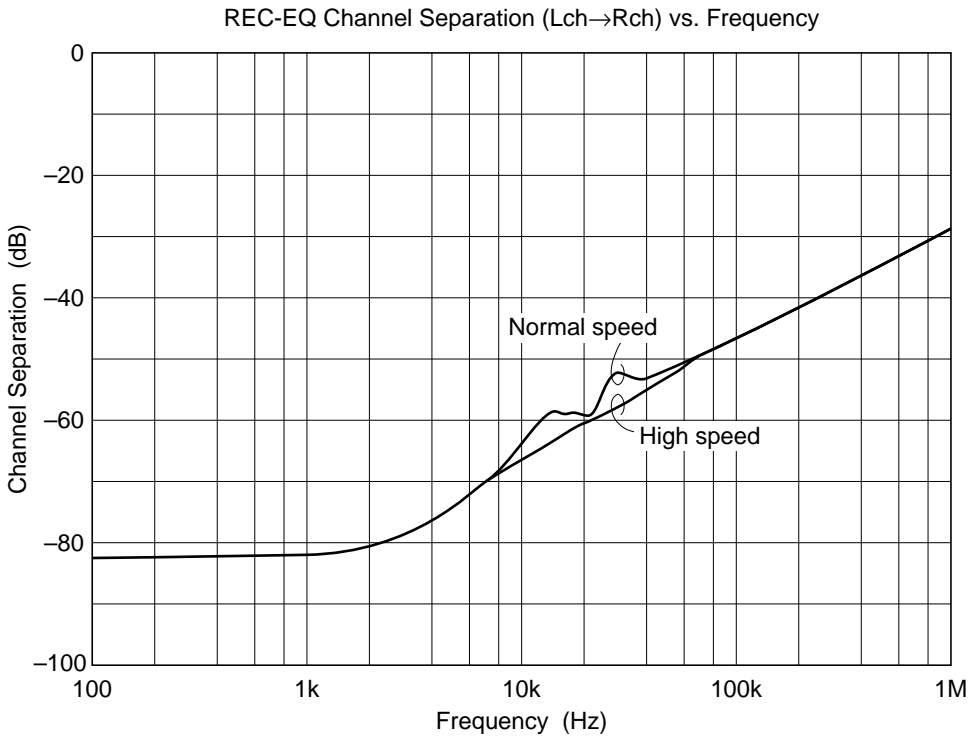
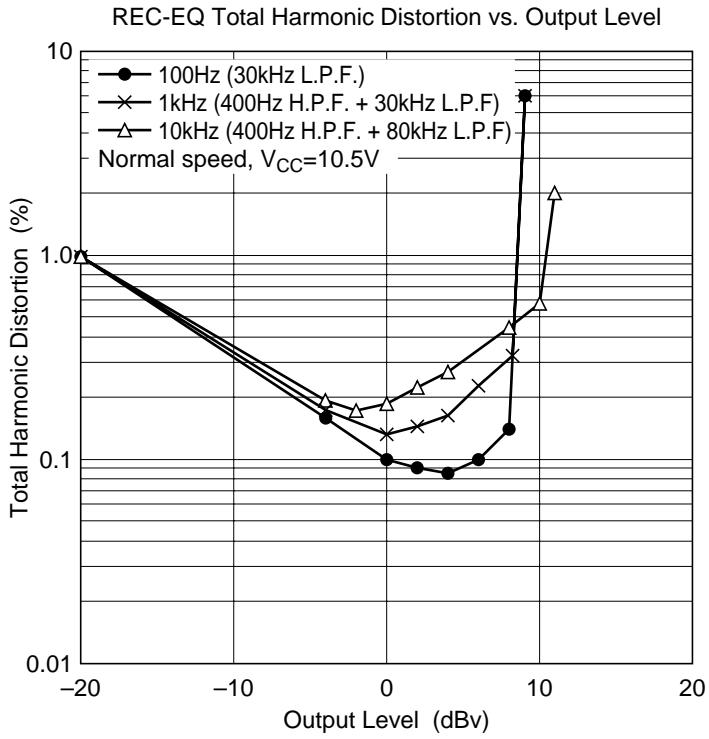

Mute Attenuation vs. Frequency

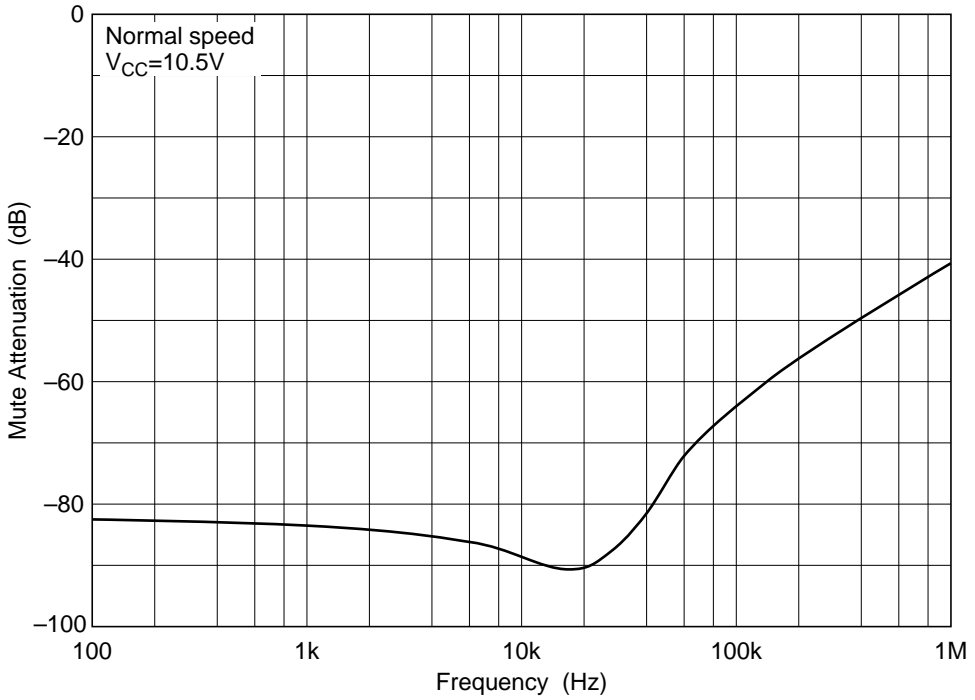

REC-RETURN SW Resistor vs. Input Level

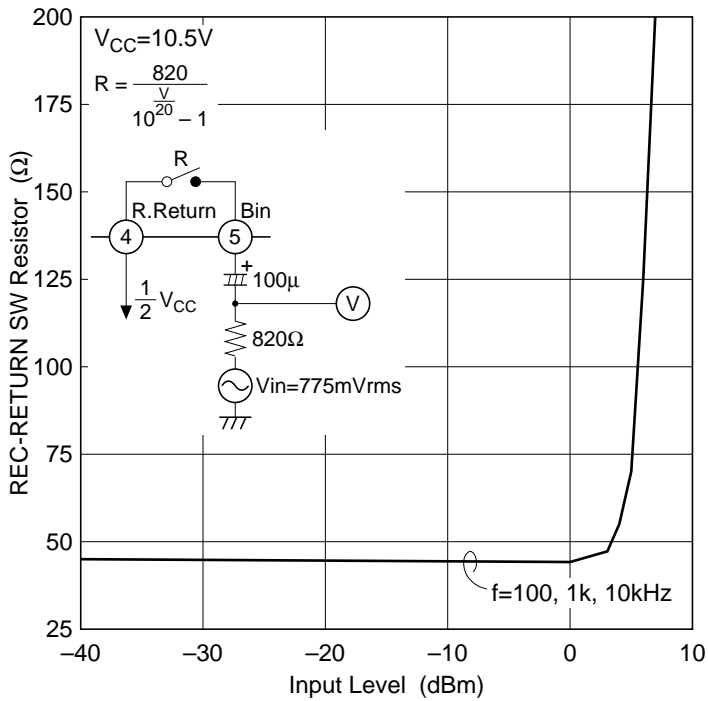

HA12207NT

Package Dimensions

Unit: mm

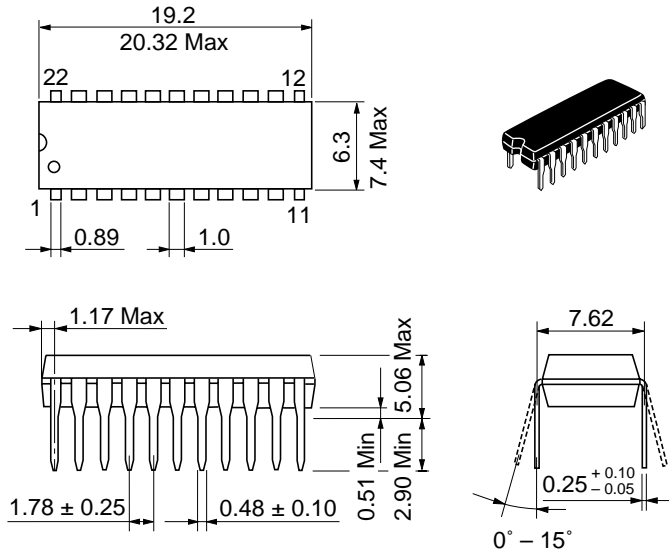

Hitachi Code	DP-22NS
JEDEC	—
EIAJ	Conforms
Weight (reference value)	0.90 g

Disclaimer

1. Hitachi neither warrants nor grants licenses of any rights of Hitachi's or any third party's patent, copyright, trademark, or other intellectual property rights for information contained in this document. Hitachi bears no responsibility for problems that may arise with third party's rights, including intellectual property rights, in connection with use of the information contained in this document.
2. Products and product specifications may be subject to change without notice. Confirm that you have received the latest product standards or specifications before final design, purchase or use.
3. Hitachi makes every attempt to ensure that its products are of high quality and reliability. However, contact Hitachi's sales office before using the product in an application that demands especially high quality and reliability or where its failure or malfunction may directly threaten human life or cause risk of bodily injury, such as aerospace, aeronautics, nuclear power, combustion control, transportation, traffic, safety equipment or medical equipment for life support.
4. Design your application so that the product is used within the ranges guaranteed by Hitachi particularly for maximum rating, operating supply voltage range, heat radiation characteristics, installation conditions and other characteristics. Hitachi bears no responsibility for failure or damage when used beyond the guaranteed ranges. Even within the guaranteed ranges, consider normally foreseeable failure rates or failure modes in semiconductor devices and employ systemic measures such as fail-safes, so that the equipment incorporating Hitachi product does not cause bodily injury, fire or other consequential damage due to operation of the Hitachi product.
5. This product is not designed to be radiation resistant.
6. No one is permitted to reproduce or duplicate, in any form, the whole or part of this document without written approval from Hitachi.
7. Contact Hitachi's sales office for any questions regarding this document or Hitachi semiconductor products.

Sales Offices

HITACHI

Hitachi, Ltd.

Semiconductor & Integrated Circuits.
 Nippon Bldg., 2-6-2, Ohte-machi, Chiyoda-ku, Tokyo 100-0004, Japan
 Tel: Tokyo (03) 3270-2111 Fax: (03) 3270-5109

URL NorthAmerica : <http://semiconductor.hitachi.com/>
 Europe : <http://www.hitachi-eu.com/hel/ecg>
 Asia : <http://sicapac.hitachi-asia.com>
 Japan : <http://www.hitachi.co.jp/Sicd/indx.htm>

For further information write to:

Hitachi Semiconductor
 (America) Inc.
 179 East Tasman Drive,
 San Jose, CA 95134
 Tel: <1>(408) 433-1990
 Fax: <1>(408) 433-0223

Hitachi Europe GmbH
 Electronic Components Group
 Dornacher Straße 3
 D-85622 Feldkirchen, Munich
 Germany
 Tel: <49> (89) 9 9180-0
 Fax: <49> (89) 9 29 30 00

 Hitachi Europe Ltd.
 Electronic Components Group.
 Whitebrook Park
 Lower Cookham Road
 Maidenhead
 Berkshire SL6 8YA, United Kingdom
 Tel: <44> (1628) 585000
 Fax: <44> (1628) 585160

Hitachi Asia Ltd.
 Hitachi Tower
 16 Collyer Quay #20-00,
 Singapore 049318
 Tel : <65>-538-6533/538-8577
 Fax : <65>-538-6933/538-3877
 URL : <http://www.hitachi.com.sg>

Hitachi Asia Ltd.
 (Taipei Branch Office)
 4/F, No. 167, Tun Hwa North Road,
 Hung-Kuo Building,
 Taipei (105), Taiwan
 Tel : <886>-(2)-2718-3666
 Fax : <886>-(2)-2718-8180
 Telex : 23222 HAS-TP
 URL : <http://www.hitachi.com.tw>

Hitachi Asia (Hong Kong) Ltd.
 Group III (Electronic Components)
 7/F., North Tower,
 World Finance Centre,
 Harbour City, Canton Road
 Tsim Sha Tsui, Kowloon,
 Hong Kong
 Tel : <852>-(2)-735-9218
 Fax : <852>-(2)-730-0281
 URL : <http://www.hitachi.com.hk>

Copyright © Hitachi, Ltd., 2000. All rights reserved. Printed in Japan.
 Colophon 2.0

This datasheet has been downloaded from:

www.DatasheetCatalog.com

Datasheets for electronic components.



LittleDiode supplies new, hard to find or obsolete electronic components and semiconductors all over the world.

With over two million different components listed you are sure to find the part you need.

Feel free to visit us today at our online store:

LittleDiode.com

Looking forward to providing you with the best possible service.