

To all our customers

---

## **Regarding the change of names mentioned in the document, such as Hitachi Electric and Hitachi XX, to Renesas Technology Corp.**

---

The semiconductor operations of Mitsubishi Electric and Hitachi were transferred to Renesas Technology Corporation on April 1st 2003. These operations include microcomputer, logic, analog and discrete devices, and memory chips other than DRAMs (flash memory, SRAMs etc.) Accordingly, although Hitachi, Hitachi, Ltd., Hitachi Semiconductors, and other Hitachi brand names are mentioned in the document, these names have in fact all been changed to Renesas Technology Corp. Thank you for your understanding. Except for our corporate trademark, logo and corporate statement, no changes whatsoever have been made to the contents of the document, and these changes do not constitute any alteration to the contents of the document itself.

Renesas Technology Home Page: <http://www.renesas.com>

Renesas Technology Corp.  
Customer Support Dept.  
April 1, 2003

## Cautions

Keep safety first in your circuit designs!

1. Renesas Technology Corporation puts the maximum effort into making semiconductor products better and more reliable, but there is always the possibility that trouble may occur with them. Trouble with semiconductors may lead to personal injury, fire or property damage.

Remember to give due consideration to safety when making your circuit designs, with appropriate measures such as (i) placement of substitutive, auxiliary circuits, (ii) use of nonflammable material or (iii) prevention against any malfunction or mishap.

Notes regarding these materials

1. These materials are intended as a reference to assist our customers in the selection of the Renesas Technology Corporation product best suited to the customer's application; they do not convey any license under any intellectual property rights, or any other rights, belonging to Renesas Technology Corporation or a third party.
2. Renesas Technology Corporation assumes no responsibility for any damage, or infringement of any third-party's rights, originating in the use of any product data, diagrams, charts, programs, algorithms, or circuit application examples contained in these materials.
3. All information contained in these materials, including product data, diagrams, charts, programs and algorithms represents information on products at the time of publication of these materials, and are subject to change by Renesas Technology Corporation without notice due to product improvements or other reasons. It is therefore recommended that customers contact Renesas Technology Corporation or an authorized Renesas Technology Corporation product distributor for the latest product information before purchasing a product listed herein.  
The information described here may contain technical inaccuracies or typographical errors. Renesas Technology Corporation assumes no responsibility for any damage, liability, or other loss rising from these inaccuracies or errors.  
Please also pay attention to information published by Renesas Technology Corporation by various means, including the Renesas Technology Corporation Semiconductor home page (<http://www.renesas.com>).
4. When using any or all of the information contained in these materials, including product data, diagrams, charts, programs, and algorithms, please be sure to evaluate all information as a total system before making a final decision on the applicability of the information and products. Renesas Technology Corporation assumes no responsibility for any damage, liability or other loss resulting from the information contained herein.
5. Renesas Technology Corporation semiconductors are not designed or manufactured for use in a device or system that is used under circumstances in which human life is potentially at stake. Please contact Renesas Technology Corporation or an authorized Renesas Technology Corporation product distributor when considering the use of a product contained herein for any specific purposes, such as apparatus or systems for transportation, vehicular, medical, aerospace, nuclear, or undersea repeater use.
6. The prior written approval of Renesas Technology Corporation is necessary to reprint or reproduce in whole or in part these materials.
7. If these products or technologies are subject to the Japanese export control restrictions, they must be exported under a license from the Japanese government and cannot be imported into a country other than the approved destination.  
Any diversion or reexport contrary to the export control laws and regulations of Japan and/or the country of destination is prohibited.
8. Please contact Renesas Technology Corporation for further details on these materials or the products contained therein.

---

# HA16158P/FP

PFC & PWM Control IC

**RENESAS**

ADE-204-072 (Z)

Rev.0  
Aug. 2002

---

## Description

The HA16158 is a power supply controller IC combining an AC-DC converter switching controller for power factor correction and an off-line power supply switching controller. The PFC (power factor correction) section employs average current mode PWM and the off-line power supply control section employs peak current mode PWM.

The HA16158 allows the operating frequency to be varied with a single timing resistance, enabling it to be used for a variety of applications.

The PFC operation can be turned on and off by an external control signal. Use of this on/off function makes it possible to disable PFC operation at a low line voltage, or to perform remote control operation from the transformer secondary side.

The PWM controller includes a power-saving function that reduces the operating frequency to a maximum of 1/64 in the standby state, greatly decreasing switching loss.

The PFC section and PWM section are each provided with a soft start control pin, enabling a soft start time to be set easily.

## Features

### <Maximum Ratings>

- Supply voltage  $V_{cc}$ : 24 V
- Operating junction temperature  $T_{jopr}$ :  $-40^{\circ}\text{C}$  to  $+125^{\circ}\text{C}$

### <Electrical Characteristics>

- VREF output voltage  $V_{REF}$ :  $5.0\text{ V} \pm 2\%$
- UVLO start threshold  $V_H$ :  $16.0\text{ V} \pm 1.0\text{ V}$
- UVLO shutdown threshold  $V_L$ :  $10.0\text{ V} \pm 0.6\text{ V}$
- PFC output maximum duty cycle  $D_{max-pfc}$ : 95% typ.
- PWM output maximum duty cycle  $D_{max-pwm}$ : 45% typ.

### <Functions>

- Synchronized PFC and PWM timing
- PFC function on/off control
- PWM power-saving function (frequency reduced to maximum of 1/64)
- PWM overvoltage latch protection circuit
- Soft start control circuits for both PFC and PWM
- Package lineup: SOP-16/DILP-16

## Pin Arrangement

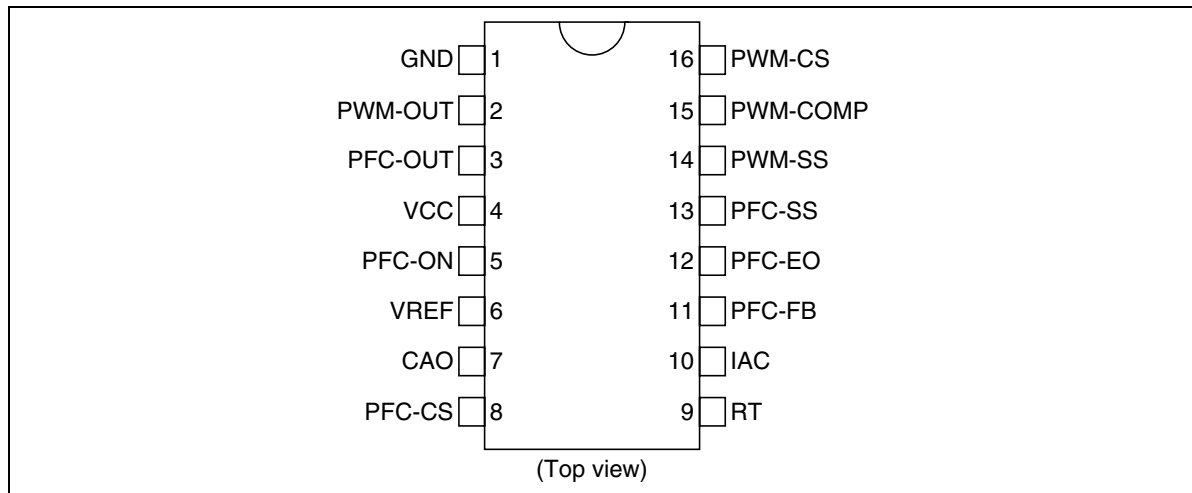

## Pin Functions

Pin No.	Pin Name	Pin Function
1	GND	Ground
2	PWM-OUT	Power MOS FET driver output (PWM control)
3	PFC-OUT	Power MOS FET driver output (PFC control)
4	VCC	Supply voltage
5	PFC-ON	PFC function on/off signal input
6	VREF	Reference voltage
7	CAO	Average current control error amplifier output
8	PFC-CS	PFC control current sense signal input
9	RT	Operating frequency setting timing resistance connection
10	IAC	Multiplier reference current input
11	PFC-FB	PFC control error amplifier input
12	PFC-EO	PFC control error amplifier output
13	PFC-SS	PFC control soft start time setting capacitance connection
14	PWM-SS	PWM control soft start time setting capacitance connection
15	PWM-COMP	PWM control voltage feedback
16	PWM-CS	PWM control current sense signal input

Block Diagram

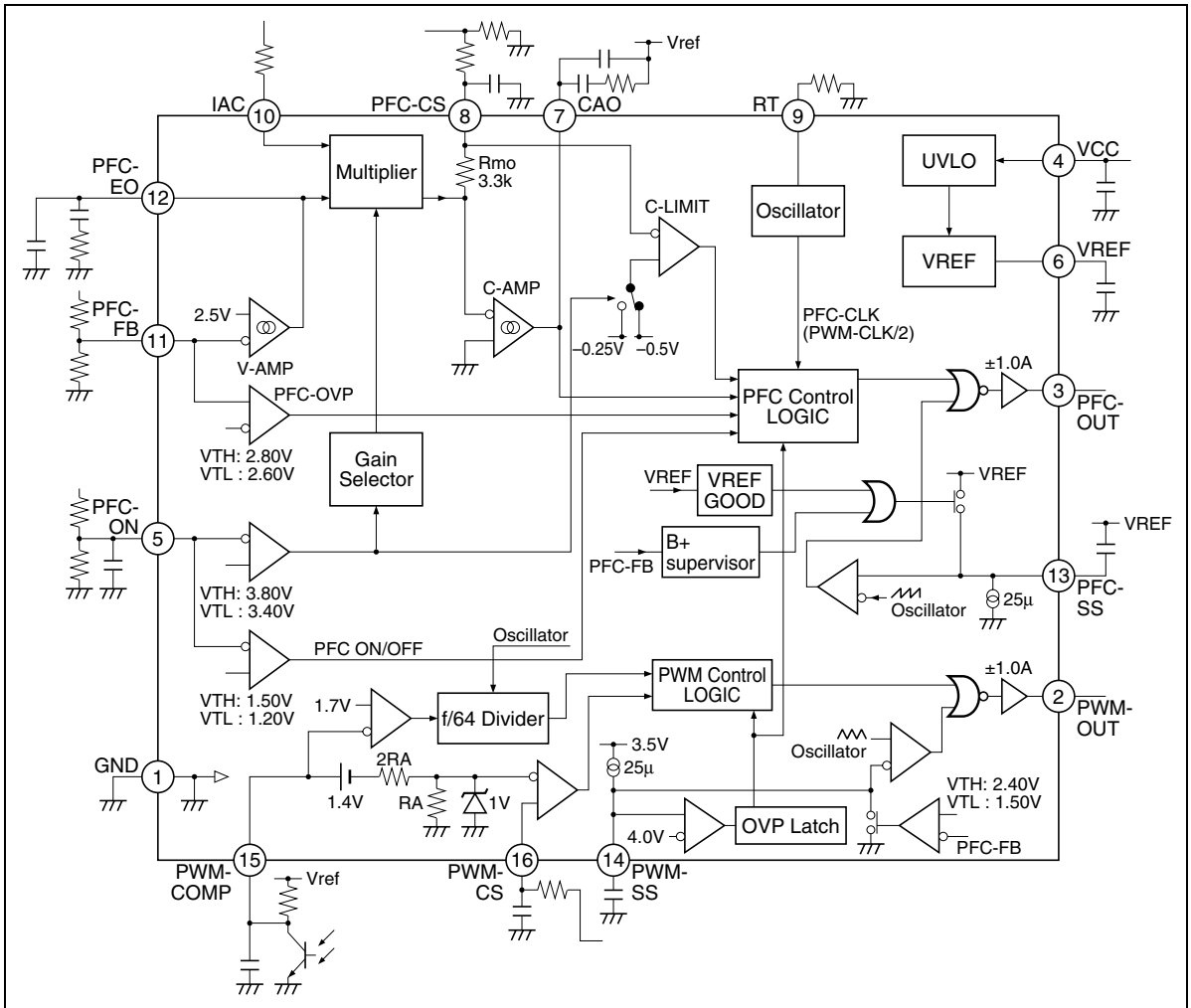

## Absolute Maximum Ratings

(Ta = 25°C)

Item	Symbol	Ratings	Unit	Note
Power supply voltage	Vcc	24	V	
PFC-OUT output current (peak)	l <sub>pk-out1</sub>	±1.0	A	3
PWM-OUT output current (peak)	l <sub>pk-out2</sub>	±1.0	A	3
PFC-OUT output current (DC)	l <sub>dc-out1</sub>	±0.1	A	
PWM-OUT output current (DC)	l <sub>dc-out2</sub>	±0.1	A	
Pin voltage	Vi-group1	−0.3 to Vcc	V	4
	Vi-group2	−0.3 to Vref	V	5
CAO pin voltage	V <sub>cao</sub>	−0.3 to V <sub>eh-ca</sub>	V	
PFC-EO pin voltage	V <sub>pfc-eo</sub>	−0.3 to V <sub>eh-pfc</sub>	V	
PFC-ON pin voltage	V <sub>pfc-on</sub>	−0.3 to 7	V	
RT pin current	I <sub>rt</sub>	50	μA	
IAC pin current	I <sub>iac</sub>	1	mA	
PFC-CS pin voltage	Vi-cs	−1.5 to 0.3	V	
VREF pin current	I <sub>o-ref</sub>	−20	mA	
VREF pin voltage	Vref	−0.3 to Vref	V	
Operating junction temperature	T <sub>j-opr</sub>	−40 to +125	°C	6
Storage temperature	T <sub>stg</sub>	−55 to +150	°C	

Notes: 1. Rated voltages are with reference to the GND (SGND, PGND) pin.

2. For rated currents, inflow to the IC is indicated by (+), and outflow by (−).

3. Shows the transient current when driving a capacitive load.

4. Group1 is the rated voltage for the following pins:

PFC-OUT, PWM-OUT

5. Group2 is the rated voltage for the following pins:

PFC-FB, PWM-CS, PWM-COMP, IAC, PFC-SS, PWM-SS, RT

6. HA16158P (DILP):  $\theta_{ja} = 120^{\circ}\text{C/W}$

HA16158FP (SOP):  $\theta_{ja} = 120^{\circ}\text{C/W}$

This value is based on actual measurements on a 10% wiring density glass epoxy circuit board (40 mm × 40 mm × 1.6 mm).

## Electrical Characteristics

(Ta = 25°C, Vcc = 12 V, RT = 200 kΩ)

Item	Symbol	Min	Typ	Max	Unit	Test Conditions	
Supply	Start threshold	VH	15.0	16.0	17.0	V	
	Shutdown threshold	VL	9.4	10.0	10.6	V	
	UVLO hysteresis	dV <sub>UVL</sub>	5.2	6.0	6.8	V	
	Start-up current	I <sub>s</sub>	160	220	280	μA	Vcc = 14.8V
	I <sub>s</sub> temperature stability	dI <sub>s</sub> /dT <sub>a</sub>	—	-0.3	—	%/°C	*1
	Operating current	I <sub>cc</sub>	5.5	7.0	8.5	mA	IAC = 0A, CL = 0F
	Shunt zenner voltage	V <sub>z</sub>	25.5	27.5	29.5	V	I <sub>cc</sub> = 14mA
	V <sub>z</sub> temperature stability	dV <sub>z</sub> /dT <sub>a</sub>	—	-4	—	mV/°C	I <sub>cc</sub> = 14mA *1
	Latch current	ILATCH	180	250	320	μA	Vcc = 9V
VREF	Output voltage	V <sub>ref</sub>	4.9	5.0	5.1	V	I <sub>source</sub> = 1mA
	Line regulation	V <sub>ref-line</sub>	—	5	20	mV	I <sub>source</sub> = 1mA, Vcc = 12V to 23V
	Load regulation	V <sub>ref-load</sub>	—	5	20	mV	I <sub>source</sub> = 1mA to 20mA
	Temperature stability	dV <sub>ref</sub>	—	80	—	ppm/°C	Ta = -40 to 125°C *1
Oscillator	Initial accuracy	fpwm	117	130	143	kHz	Measured pin: PWM-OUT
		fpfc	58.5	65	71.5	kHz	Measured pin: PFC-OUT
	fpwm temperature stability	dfpwm/dT <sub>a</sub>	—	±0.1	—	%/°C	Ta = -40 to 125°C *1
	fpwm voltage stability	fpwm(line)	-1.5	+0.5	+1.5	%	VCC = 12V to 18V
	Ramp peak voltage	V <sub>ramp-H</sub>	—	3.6	4.0	V	PFC *1
	Ramp valley voltage	V <sub>ramp-L</sub>	—	0.65	—	V	PFC *1
	CT peak voltage	V <sub>ct-H</sub>	—	3.2	—	V	PWM *1
	CT valley voltage	V <sub>ct-L</sub>	1.50	1.60	—	V	PWM *1
Supervisor	RT voltage	V <sub>rt</sub>	0.85	1.00	1.15	V	Measured pin: RT
	PFC on voltage	V <sub>on-pfc</sub>	1.4	1.5	1.6	V	
	PFC off voltage	V <sub>off-pfc</sub>	1.1	1.2	1.3	V	
	PFC on-off hysteresis	dV <sub>on-off</sub>	0.2	0.3	0.4	V	
	Input current	I <sub>pfc-on</sub>	—	0.1	1.0	μA	PFC-ON = 2V
	PFC OVP set voltage	V <sub>ovps-pfc</sub>	2.65	2.80	2.95	V	Input pin: PFC-FB
	PFC OVP reset voltage	V <sub>ovpr-pfc</sub>	2.45	2.60	2.75	V	Input pin: PFC-FB
	PFC OVP hysteresis	dV <sub>ovp</sub>	0.10	0.20	0.30	V	
	B+ good voltage	V <sub>b-good</sub>	2.25	2.40	2.55	V	Measured pin: PFC-FB
B+ fail voltage	V <sub>b-fail</sub>	1.4	1.5	1.6	V	Measured pin: PFC-FB	
OVP latch	Latch threshold voltage	V <sub>latch</sub>	3.76	4.00	4.24	V	Input pin: PWM-SS
	Latch reset voltage	V <sub>cc-res</sub>	6.1	7.1	8.1	V	
Power saving for PWM	Power saving on voltage	V <sub>on-save</sub>	1.53	1.70	1.87	V	Measured pin: PWM-COMP
	Minimum frequency at light load	fpwm-min	—	2	—	kHz	PWM-COMP = 1.5V Measured pin: PWM-OUT *1

Note: 1. Reference values for design.

## Electrical Characteristics (cont.)

(Ta = 25°C, Vcc = 12 V, RT = 200 kΩ)

Item		Symbol	Min	Typ	Max	Unit	Test Conditions
Soft start for PWM	Soft start time	tss-pwm	—	4.2	—	ms	PWM-SS = 0V to Vct-h * <sup>1</sup>
	Source current	lss-pwm	-20.0	-25.0	-30.0	μA	Measured pin: PWM-SS
	High voltage	Vh-ss	3.25	3.5	3.75	V	Measured pin: PWM-SS
Soft start for PFC	Soft start time	tss-pfc	—	5.7	—	ms	PFC-SS = Vref to Vramp-l * <sup>1</sup>
	Source current	lss-pfc	+20.0	+25.0	+30.0	μA	Measured pin: PFC-SS
PWM current sense	Delay to output	td-cs	—	210	300	ns	PWM-EO = 5V, PWM-CS = 0 to 2V
PFC current limit	Threshold voltage	VLM1	-0.45	-0.50	-0.55	V	PFC-ON = 2V
	Threshold voltage	VLM2	-0.22	-0.25	-0.28	V	PFC-ON = 4V
	Delay to output	td-LM	—	280	500	ns	PFC-CS = 0 to -1V
PFC-VAMP	Feedback voltage	Vfb-pfc	2.45	2.50	2.55	V	PFC-EO = 2.5V
	Input bias current	lfb-pfc	-0.3	0	0.3	μA	Measured pin: PFC-FB
	Open loop gain	Av-pfc	—	65	—	dB	* <sup>1</sup>
	High voltage	Veoh-pfc	5.0	5.7	6.4	V	PFC-FB = 2.3V, PFC-EO: Open
	Low voltage	Veol-pfc	—	0.1	0.3	V	PFC-FB = 2.7V, PFC-EO: Open
	Source current	lsrc-pfc	—	-90	—	μA	PFC-FB = 1.0V, PFC-EO: 2.5V * <sup>1</sup>
	Sink current	lsnk-pfc	—	90	—	μA	PFC-FB = 4.0V, PFC-EO: 2.5V * <sup>1</sup>
	Transconductance	Gm-pfcv	150	200	250	μA/V	PFC-FB = 2.5V, PFC-EO: 2.5V
PFC-OUT	Minimum duty cycle	Dmin-pfc	—	—	0	%	CAO = 4.0V
	Maximum duty cycle	Dmax-pfc	90	95	98	%	CAO = 0V
	Rise time	tr-pfc	—	30	100	ns	CL = 1000pF
	Fall time	tf-pfc	—	30	100	ns	CL = 1000pF
	Peak current	lpk-pfc	—	1.0	—	A	CL = 0.01μF * <sup>1</sup>
	Low voltage	Vol1-pfc	—	0.05	0.2	V	Iout = 20mA
		Vol2-pfc	—	0.5	2.0	V	Iout = 200mA
		Vol3-pfc	—	0.03	0.7	V	Iout = 10mA, VCC = 5V
	High voltage	Voh1-pfc	11.5	11.9	—	V	Iout = -20mA
Voh2-pfc		10.0	11.0	—	V	Iout = -200mA	
PWM-OUT	Minimum duty cycle	Dmin-pwm	—	—	0	%	PWM-COMP = 0V
	Maximum duty cycle	Dmax-pwm	42	45	49	%	PWM-COMP = Vref
	Rise time	tr-pwm	—	30	100	ns	CL = 1000pF
	Fall time	tf-pwm	—	30	100	ns	CL = 1000pF
	Peak current	lpk-pwm	—	1.0	—	A	CL = 0.01μF * <sup>1</sup>
	Low voltage	Vol1-pwm	—	0.05	0.2	V	Iout = 20mA
		Vol2-pwm	—	0.5	2.0	V	Iout = 200mA
		Vol3-pwm	—	0.03	0.7	V	Iout = 10mA, VCC = 5V
	High voltage	Voh1-pwm	11.5	11.9	—	V	Iout = -20mA
Voh2-pwm		10.0	11.0	—	V	Iout = -200mA	

Note: 1. Reference values for design.

Electrical Characteristics (cont.)

(Ta = 25°C, Vcc = 12 V, RT = 200 kΩ)

Item	Symbol	Min	Typ	Max	Unit	Test Conditions
PFC-CAMP	Input offset voltage	Vio-ca	—	±7	—	mV *1
	Open loop gain	Av-ca	—	65	—	dB *1
	High voltage	Veoh-ca	5.0	5.7	6.4	V
	Low voltage	Veol-ca	—	0.1	0.3	V
	Source current	Isrc-ca	—	-90	—	μA CAO = 2.5V *1
	Sink current	Isnk-ca	—	90	—	μA CAO = 2.5V *1
	Transconductance	Gm-pfcc	150	200	250	μA/V *1
IAC/Multiplier	IAC pin voltage	Viac	0.7	1.0	1.3	V IAC = 100μA
	Terminal offset current	Imo-offset1	-67	-90	-113	μA IAC = 0A, PFC-ON = 2V
		Imo-offset2	-60	-80	-100	μA IAC = 0A, PFC-ON = 4V
	Output current (PFC-ON = 2.0V)	Imo1	—	-20	—	μA PFC-EO = 2V, IAC = 100μA *1,2
		Imo2	—	-60	—	μA PFC-EO = 4V, IAC = 100μA *1,2
	Output current (PFC-ON = 4.0V)	Imo3	—	-5	—	μA PFC-EO = 2V, IAC = 100μA *1,2
Imo4		—	-15	—	μA PFC-EO = 4V, IAC = 100μA *1,2	
PFC-CS resistance	Rmo	—	3.3	—	kΩ *1	
Gain selector	Threshold voltage for K = 0.05	VK-H	3.60	3.80	4.00	V Measured pin: PFC-ON
	Threshold voltage for K = 0.25	VK-L	3.20	3.40	3.60	V Measured pin: PFC-ON
	VK hysteresis	dVK	0.30	0.40	0.50	V *1

- Notes: 1. Reference values for design.  
 2. Imo1 to Imo4 are defined as:  
 $Imo = (PFC-CS \text{ pin current}) - (Imo\text{-offset})$

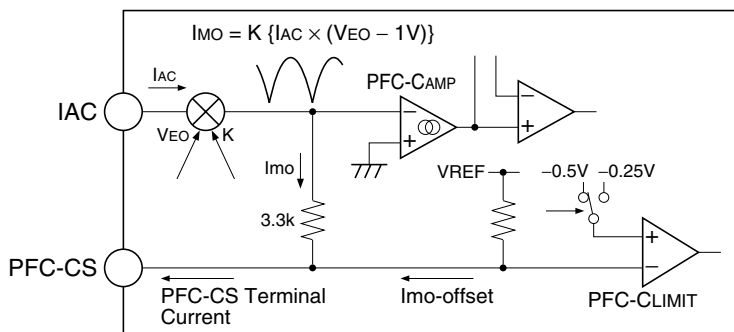

## Timing Diagram

### 1. Start-up Timing

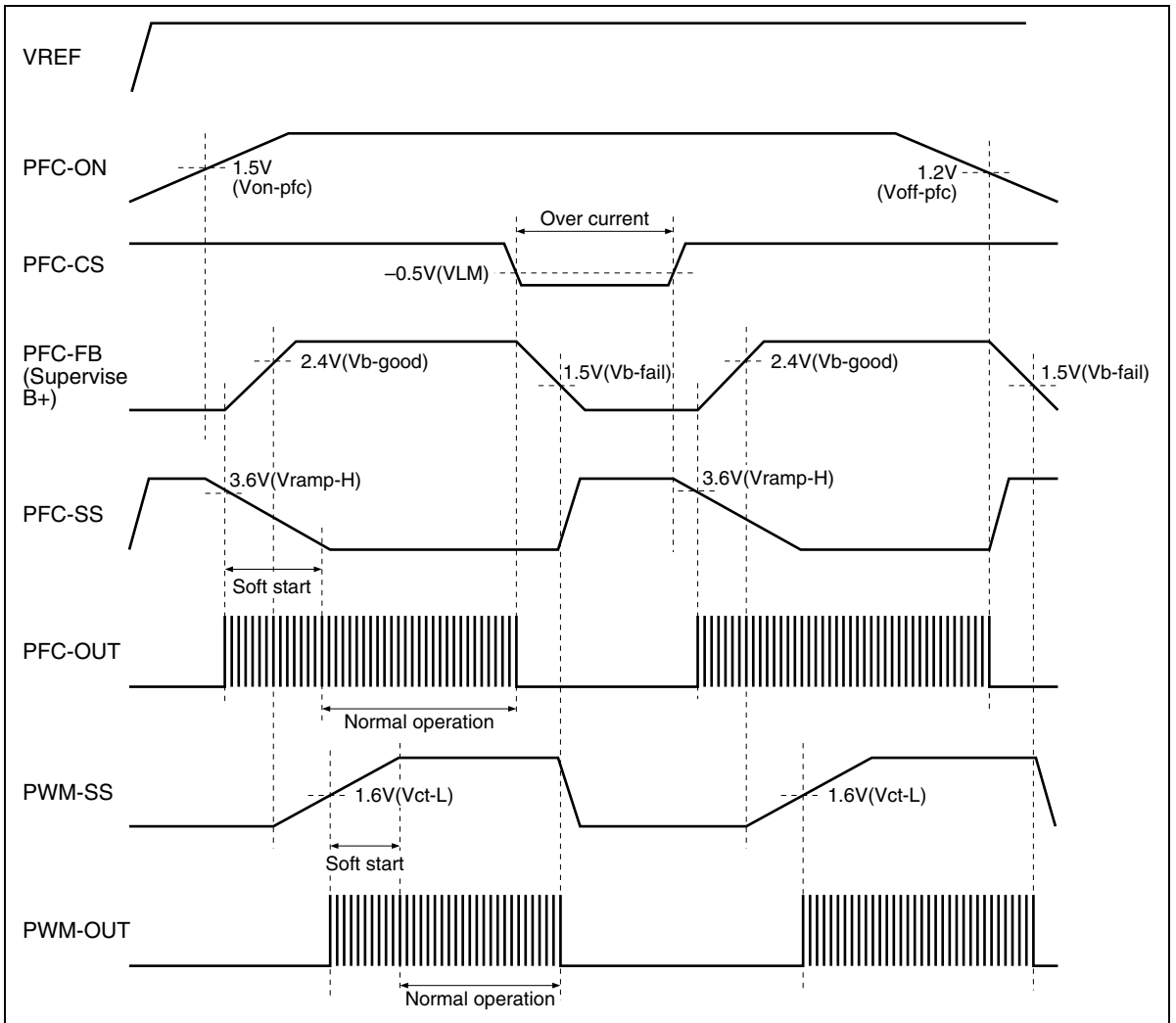

2. PWM OVP Latch

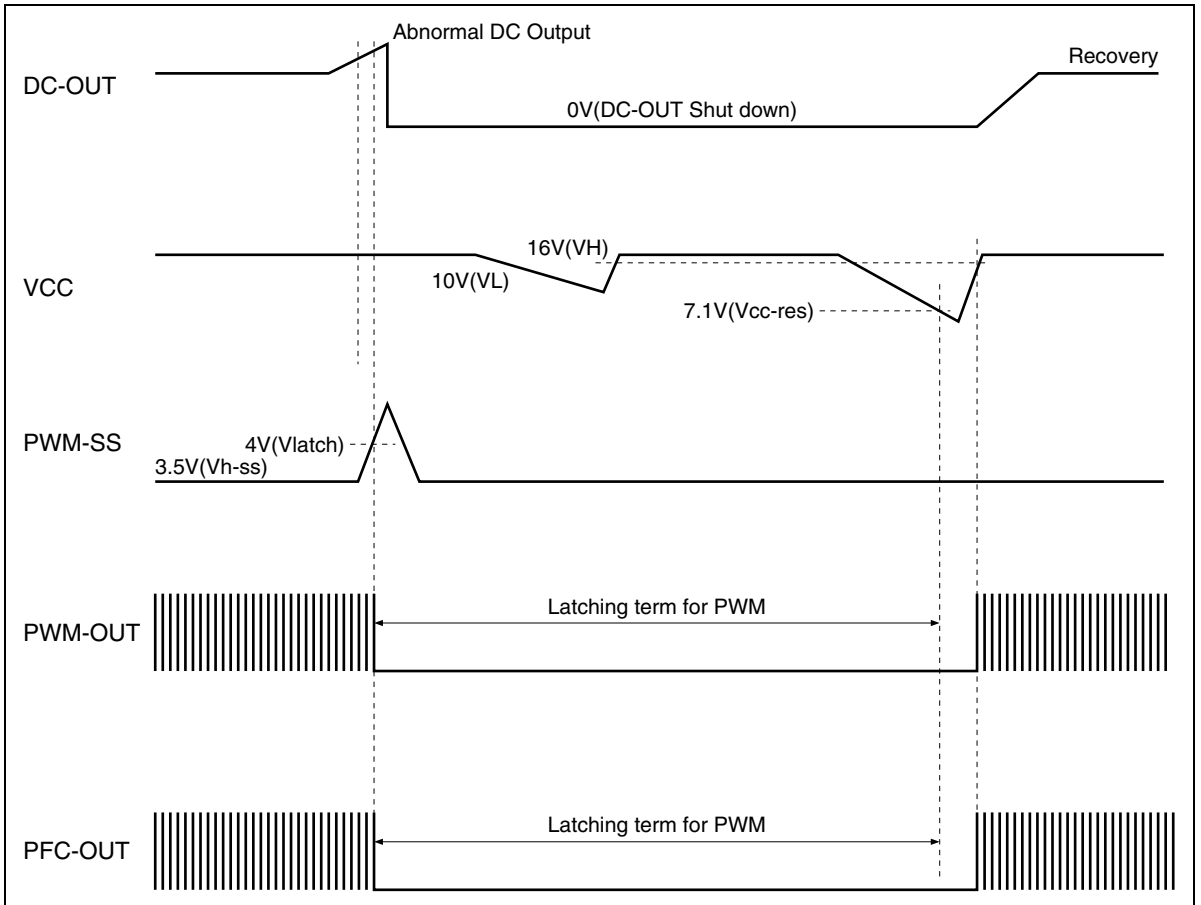

## 3. PWM Power Saving

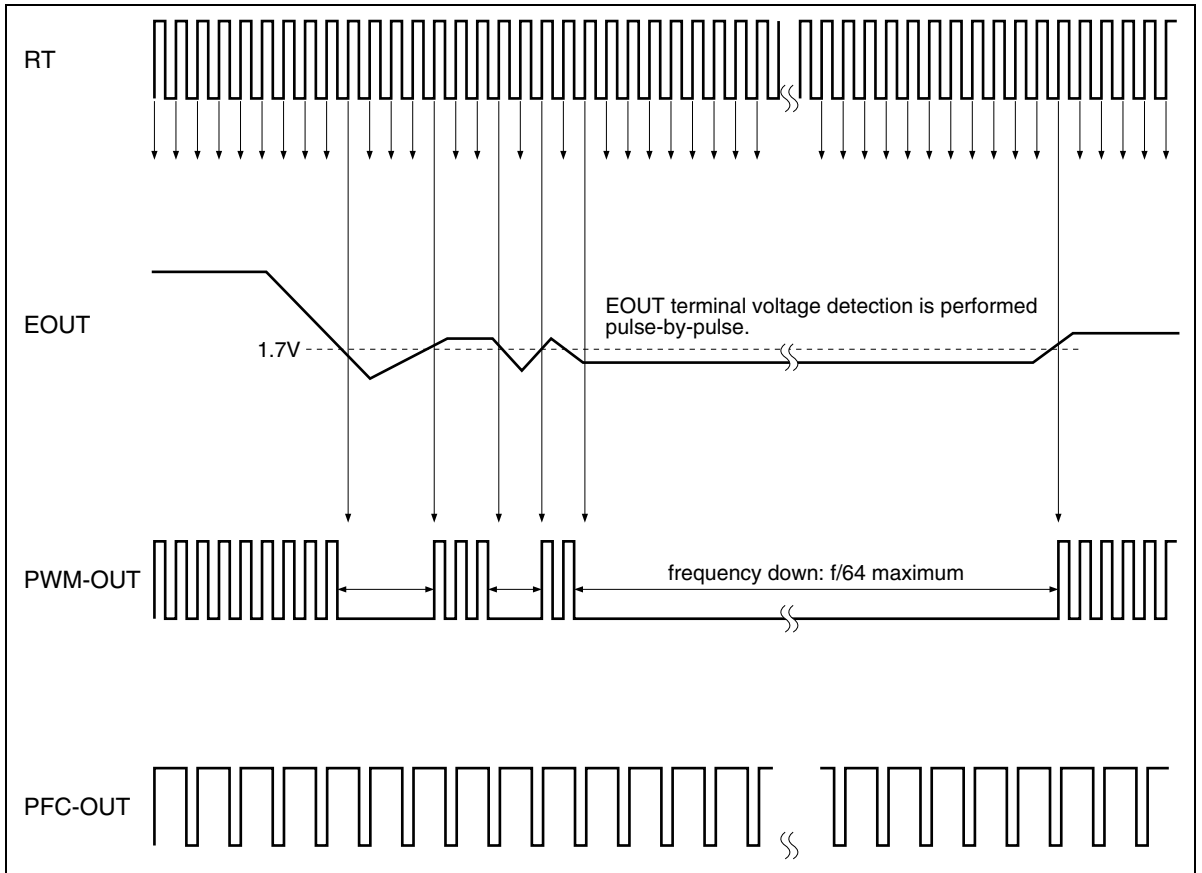

## Functional Description

### 1. UVL Circuit

The UVL circuit monitors the  $V_{cc}$  voltage and halts operation of the IC in the event of a low voltage.

The voltage for detecting  $V_{cc}$  has a hysteresis characteristic, with 16.0 V as the start threshold and 10.0 V as the shutdown threshold.

When the IC has been halted by the UVL circuit, control is performed to fix driver circuit output low and halt VREF output and the oscillator.

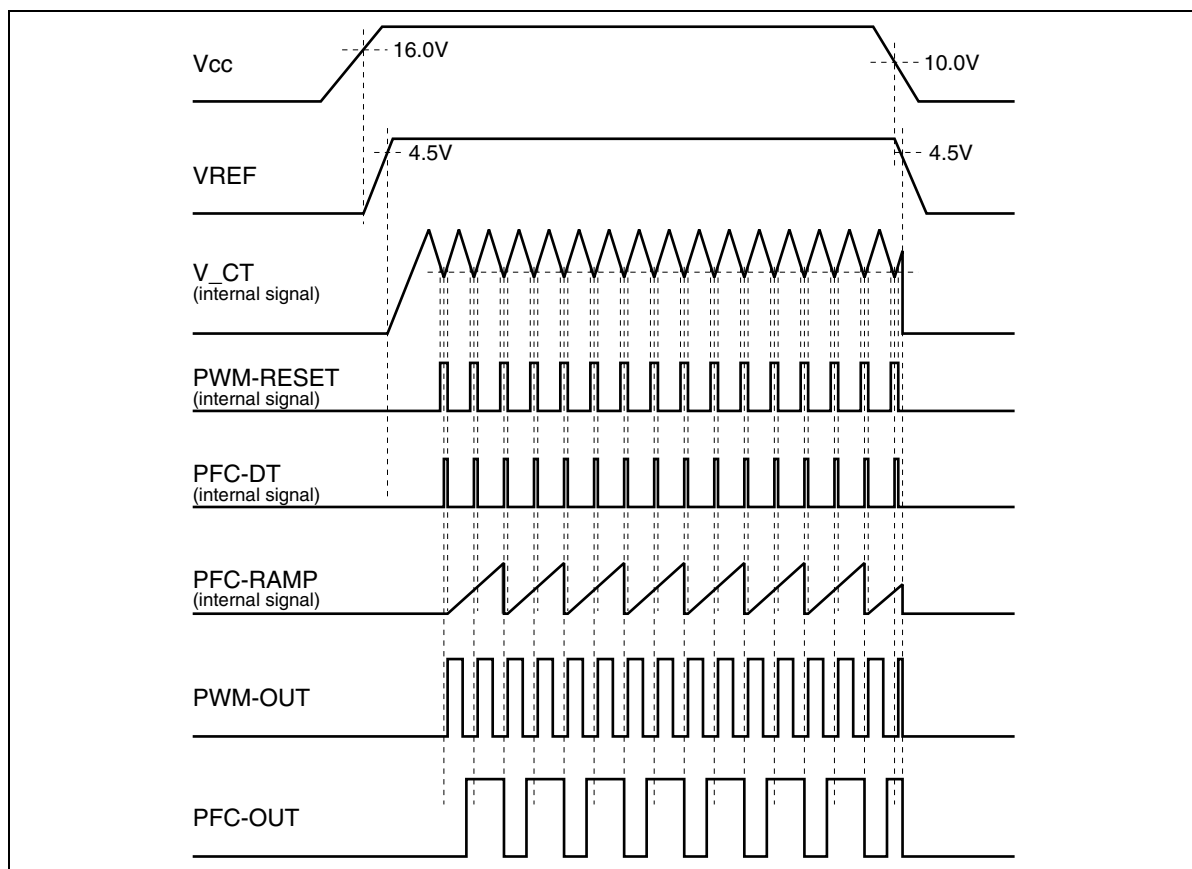
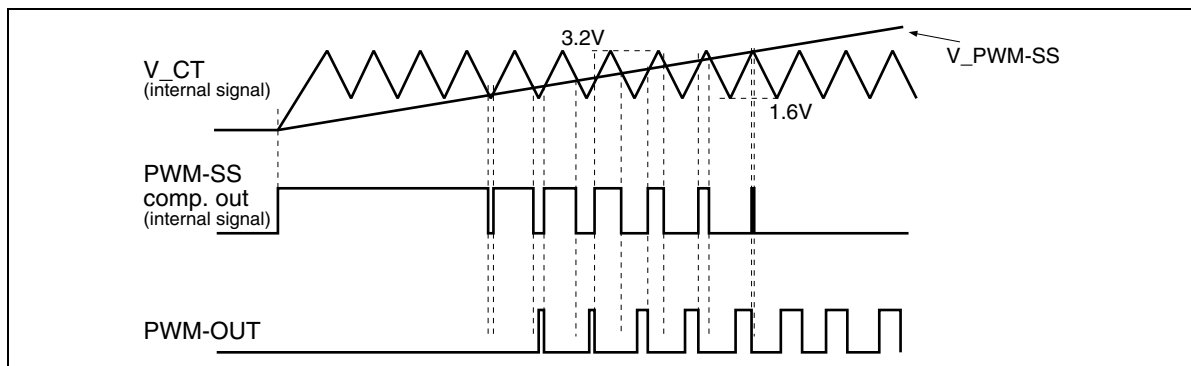

Figure 1

## 2. Soft Start Circuit (for PWM Control)

This function gradually increases the pulse width of the PWM-OUT pin from a 0% duty cycle at start-up to prevent a sudden increase in the pulse width that may cause problems such as transient stress on external parts or overshoot of the secondary-side output voltage.

The soft start time can easily be set with a single external capacitance.



**Figure 2**

Soft start time  $t_{ss-pwm}$  is determined by PWM-SS pin connection capacitance  $C_{ss-pwm}$  and an internal constant, and can be estimated using the equation shown below.

Soft start time  $t_{ss-pwm}$  is the time until the PWM-SS pin voltage reaches upper-end voltage 3.2 V of the IC-internal CT voltage waveform after VREF starts up following UVLO release.

Soft start time  $t_{ss-pwm}$  when  $C_{ss-pwm}$  is 3.3 nF is given by the following equation.

$$t_{ss-pwm} = \frac{C_{ss-pwm} \times V_{ct-H}}{I_{ss-pwm}} = \frac{33 \text{ [nF]} \times 3.2 \text{ [V]}}{25 \text{ [\mu A]}}$$

$$\approx 4.2 \text{ [ms]}$$

\*  $I_{ss-pwm}$ : PWM-SS pin source current, 25  $\mu$ A typ.

### 3. Soft Start Circuit (for PFC Control)

This function gradually increases the pulse width of the PFC-OUT pin from a 0% duty cycle at start-up to prevent a sudden increase in the pulse width that may cause problems such as transient stress on external parts or overshoot of the PFC output voltage (B+ voltage).

The soft start time can easily be set with a single external capacitance.

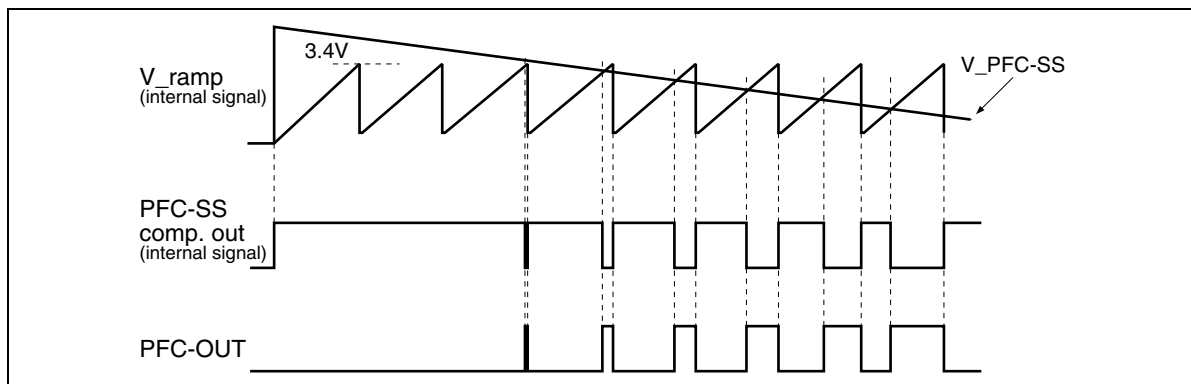

**Figure 3**

Soft start time  $t_{ss-pfc}$  is determined by PFC-SS pin connection capacitance  $C_{ss-pfc}$  and an internal constant, and can be estimated using the equation shown below.

Soft start time  $t_{ss-pfc}$  is the time until the PFC-SS pin voltage reaches lower-end voltage 0.65 V of the IC-internal RAMP voltage waveform after VREF starts up following UVLO release.

Soft start time  $t_{ss-pfc}$  when  $C_{ss-pfc}$  is 3.3 nF is given by the following equation.

$$t_{ss-pfc} = \frac{C_{ss-pfc} \times (V_{REF} - V_{ramp-L})}{I_{ss-pwm}} = \frac{33 \text{ [nF]} \times (5 - 0.65)}{25 \text{ [\mu A]}}$$

$$\approx 5.7 \text{ [ms]}$$

\*  $I_{ss-pfc}$ : PFC-SS pin sink current, 25  $\mu\text{A}$  typ.

In addition, when you do not use a soft start function, please ground this terminal.

## 4. PFC On/Off Function

On/off control of the PFC function can be performed using the PFC-ON pin.

If an AC voltage that has undergone primary rectification and has been divided by an external resistance is input, it is possible to halt PFC operation in the event of a low input voltage. On/off control is also possible by using a logic signal.

This IC also incorporates a function that automatically detects a 100 V system or 200 V system AC voltage at the PFC-ON pin, and switches multiplier gain and the PFC-CS comparison voltage.

These functions simplify the design of a power supply compatible with worldwide input.

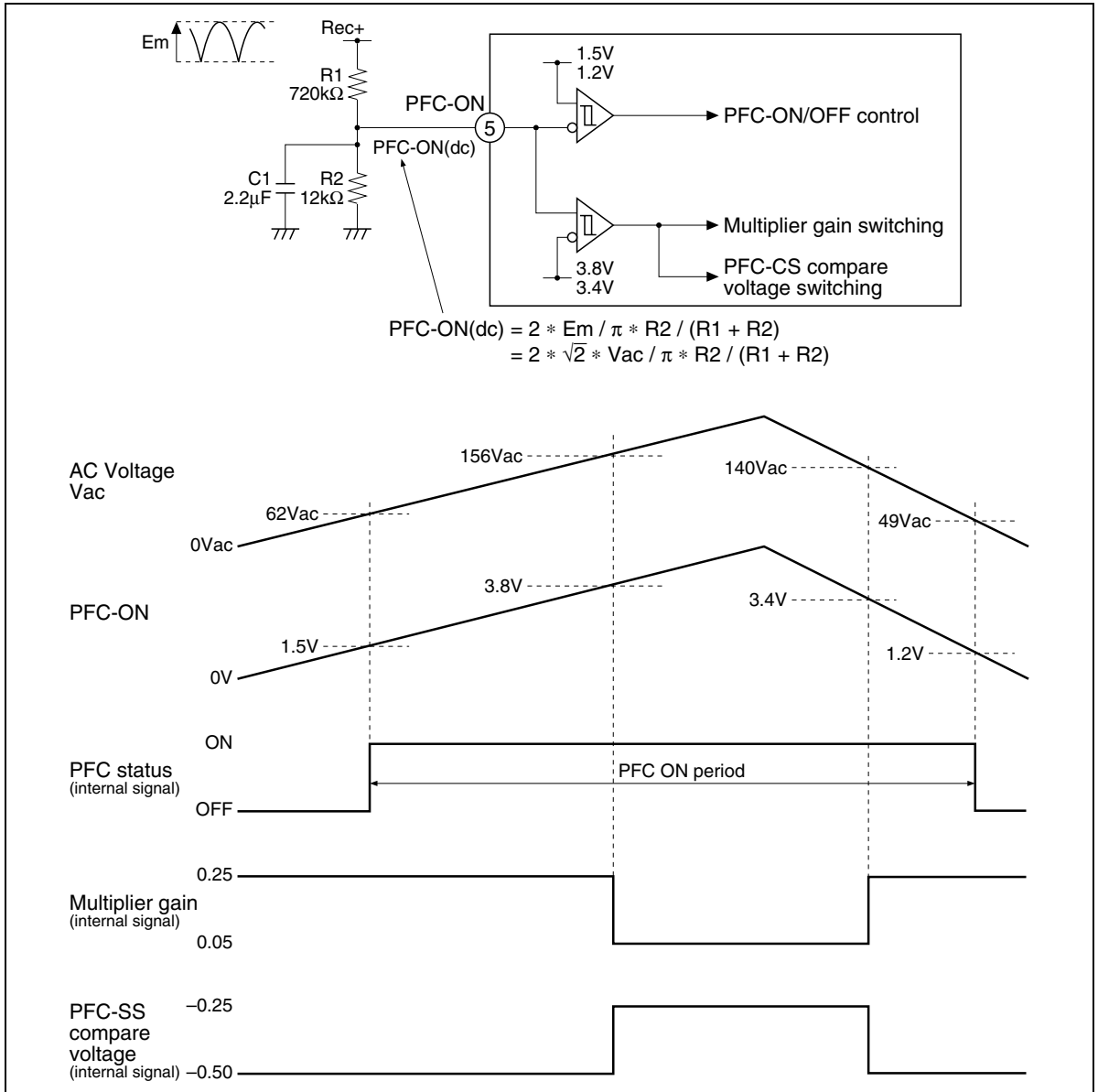

Figure 4

**5. Power Saving in Standby State (for PWM Control)**

When the output load is light, as in the standby state, the operating frequency of the PWM control section is automatically decreased in order to reduce switching loss.

Standby detection is performed by monitoring the PWM-COMP voltage, and the operating frequency is decreased to a maximum of 1/64 of the reference frequency determined by an external timing resistance.

As standby detection is performed on a reference frequency pulse-by-pulse basis, the frequency varies gently according to the output load.

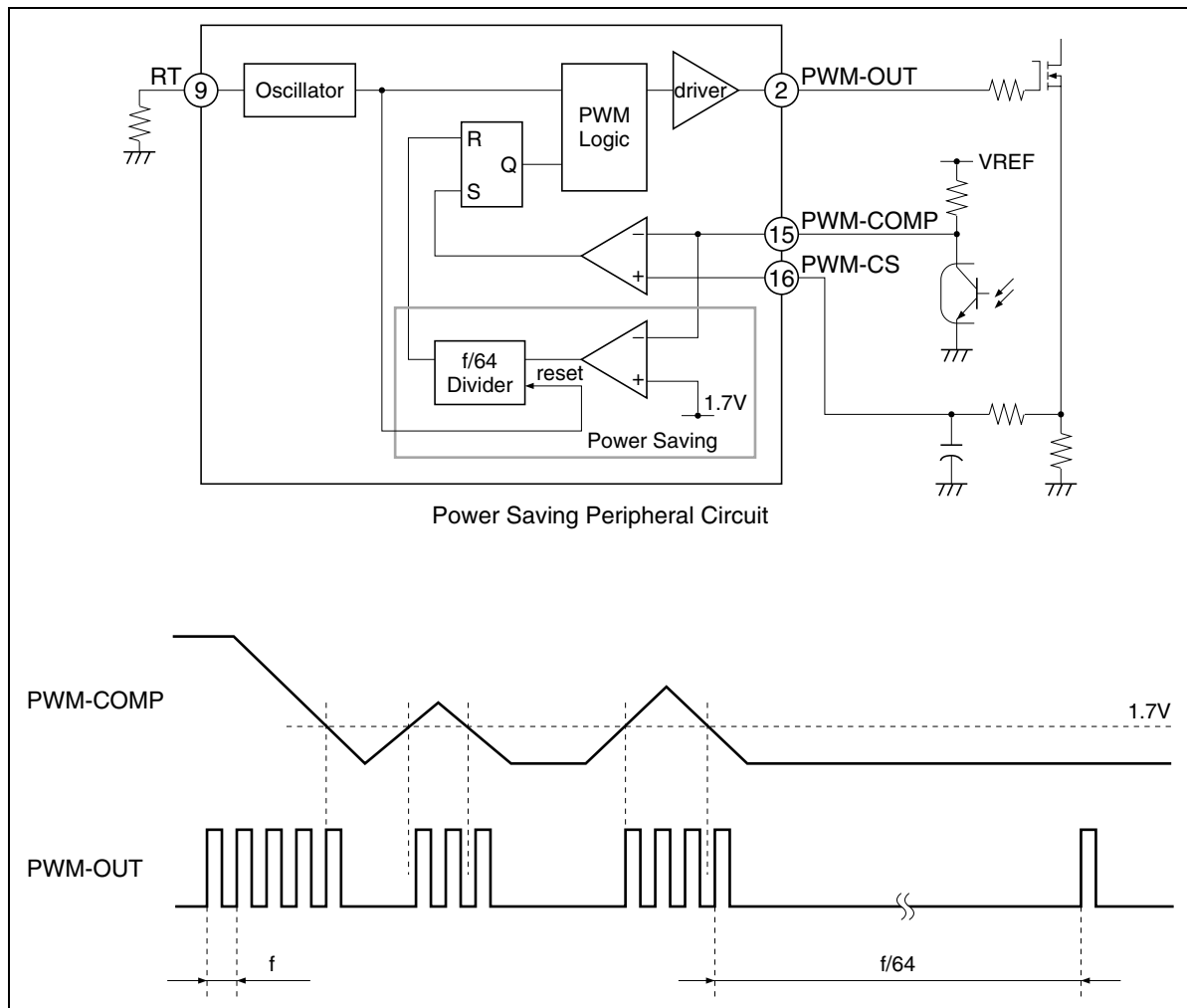

**Figure 5**

## 6. Overvoltage Latch Protection (for PWM Control)

This is a protection function that halts PWM-OUT and PFC-OUT if the secondary-side PWM output voltage is abnormally high.

Overvoltage signal input is shared with the PWM-SS pin. When this pin is pulled up to 4.0 V or higher, the control circuit identifies an overvoltage error and halts PWM-OUT and PFC-OUT.

The power supply is turned off, and the latch is released when the VCC voltage falls to 7.1 V or below.

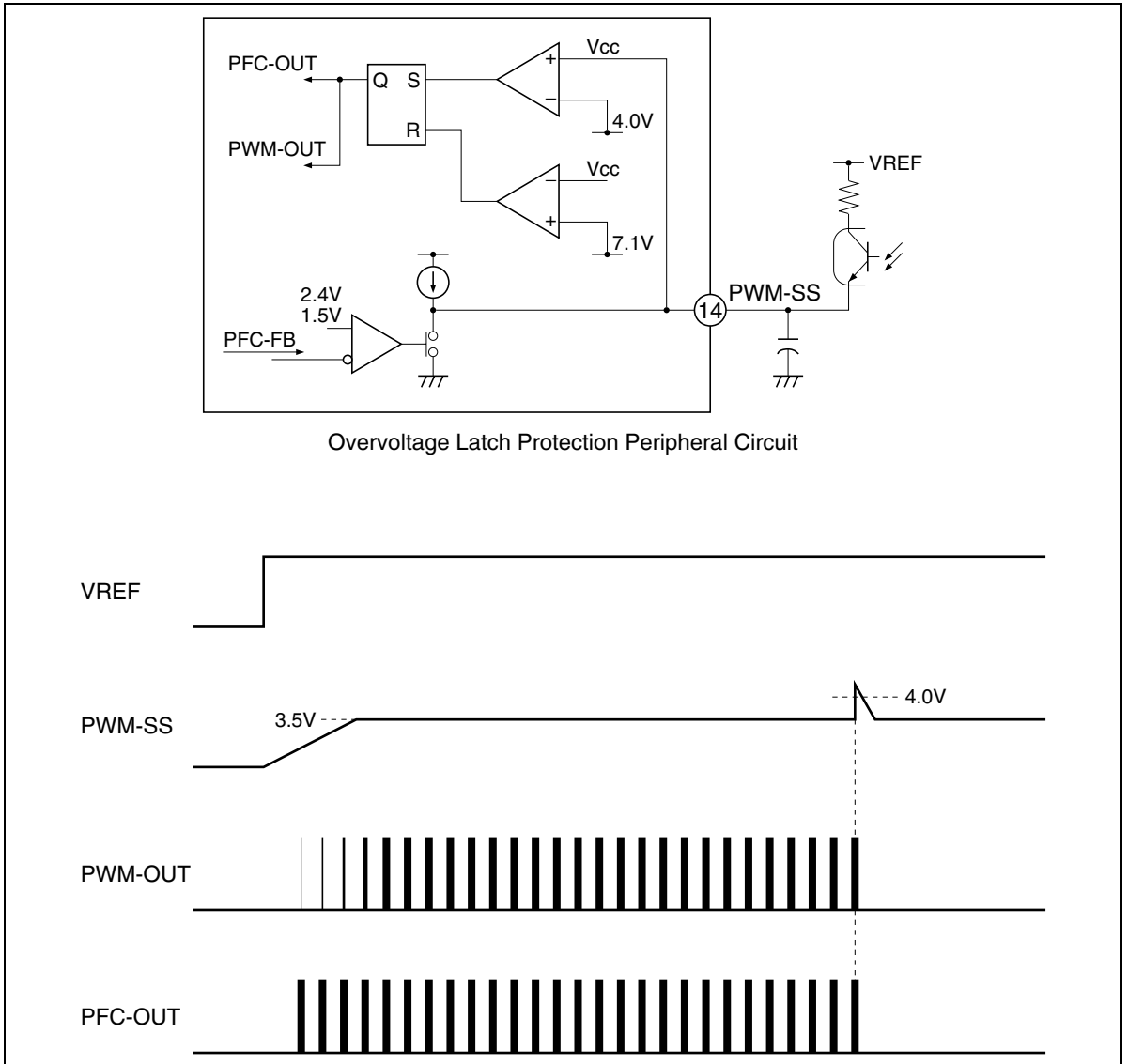

Figure 6

## 7. Operating Frequency

The operating frequency is adjusted by timing resistance RT.

Adjustment examples are shown in the graph below. The operating frequency fpwm in the PWM section is determined by the RT. The operating frequency fpfc in the PFC section is half the value of fpwm.

The operating frequency in the PWM section can be estimated using the approximate equation shown below.

RT = 200 kΩ:

$$f_{pwm} \approx \frac{2.60 \times 10^{10}}{RT} = 130 \text{ [kHz]}$$

$$f_{pfc} = \frac{f_{pwm}}{2} = 65 \text{ [kHz]}$$

This is only an approximate equation, and the higher the frequency, the greater will be the degree of error of the approximate equation due to the effects of the delay time in the internal circuit, etc.

When the operating frequency is adjusted, it is essential to confirm operation using the actual system.

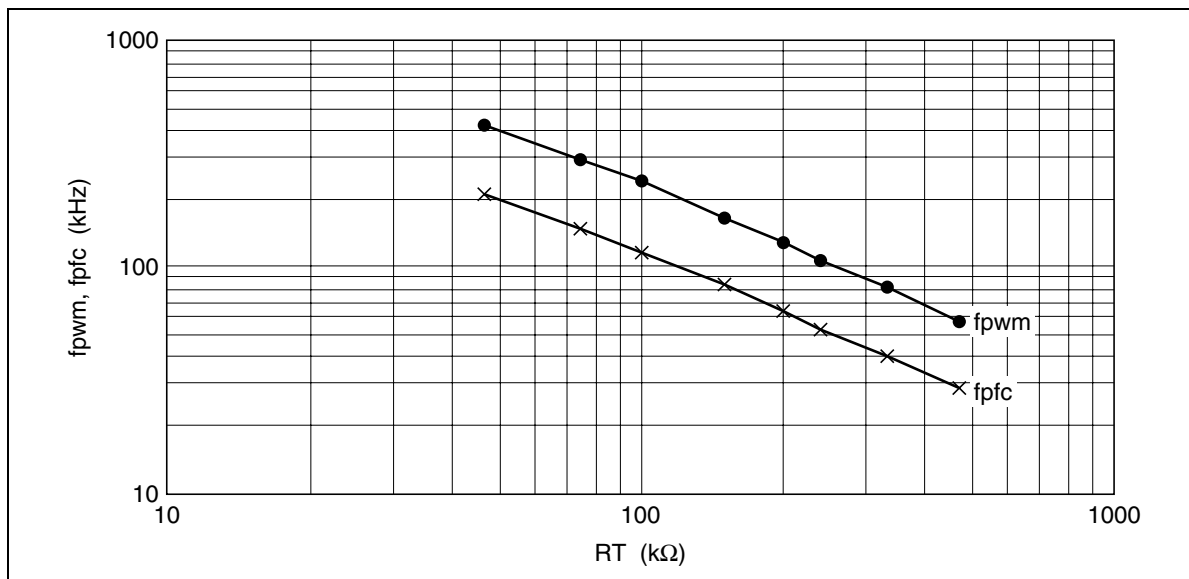
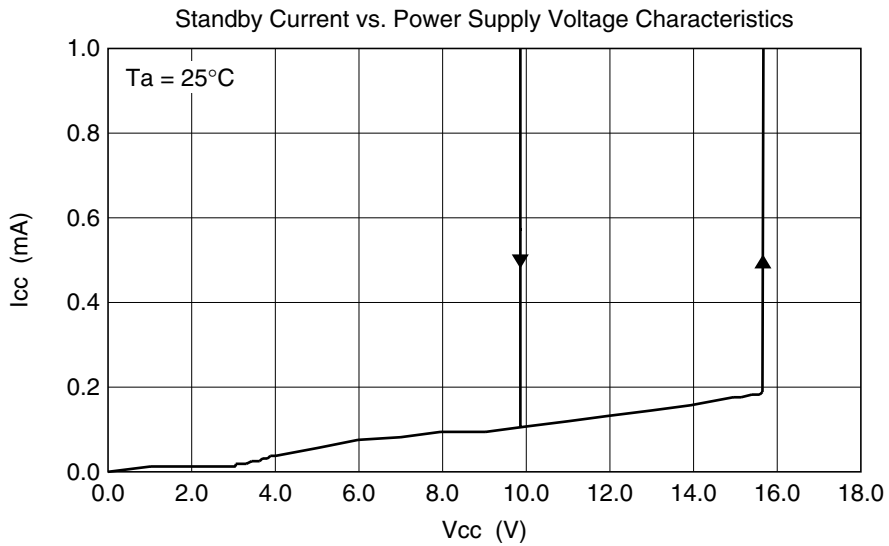
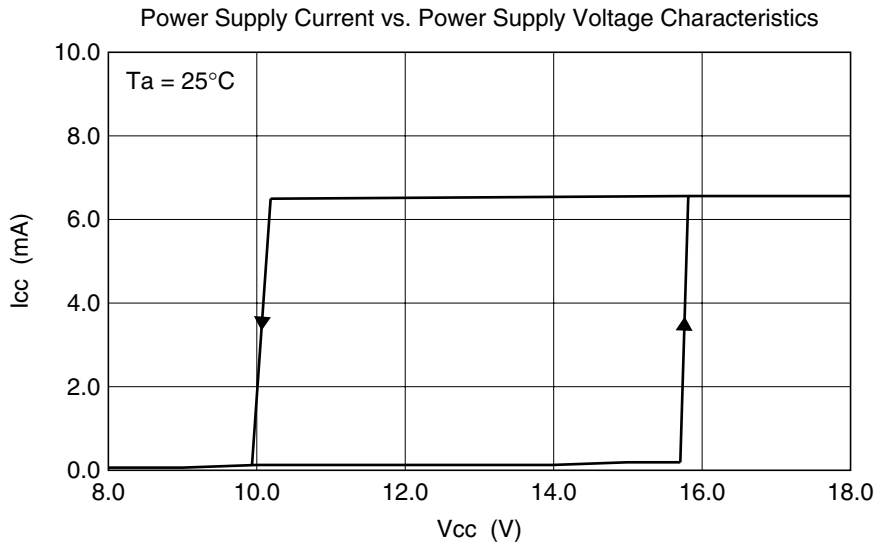
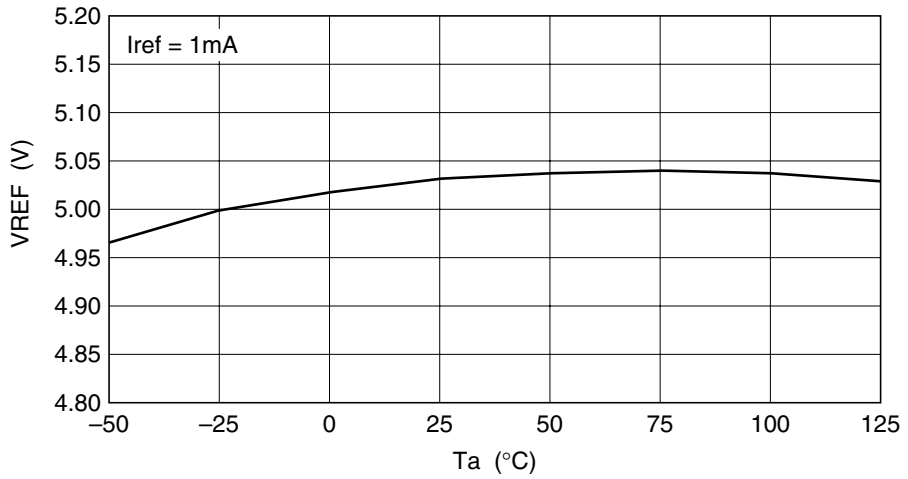

Figure 7

## Characteristic Curves



VREF Output Voltage vs. Ambient Temperature Characteristics



Operating Frequency vs. Ambient Temperature Characteristics

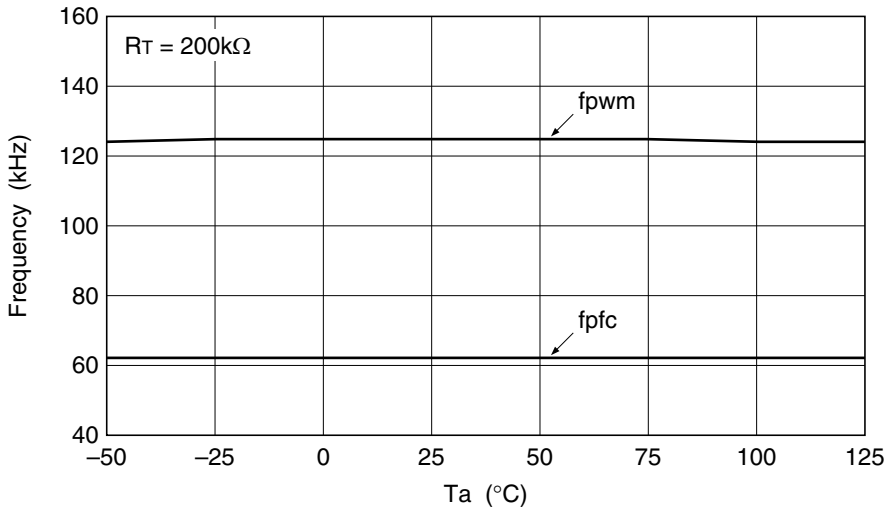

### UVL Start-up Voltage vs. Ambient Temperature Characteristics

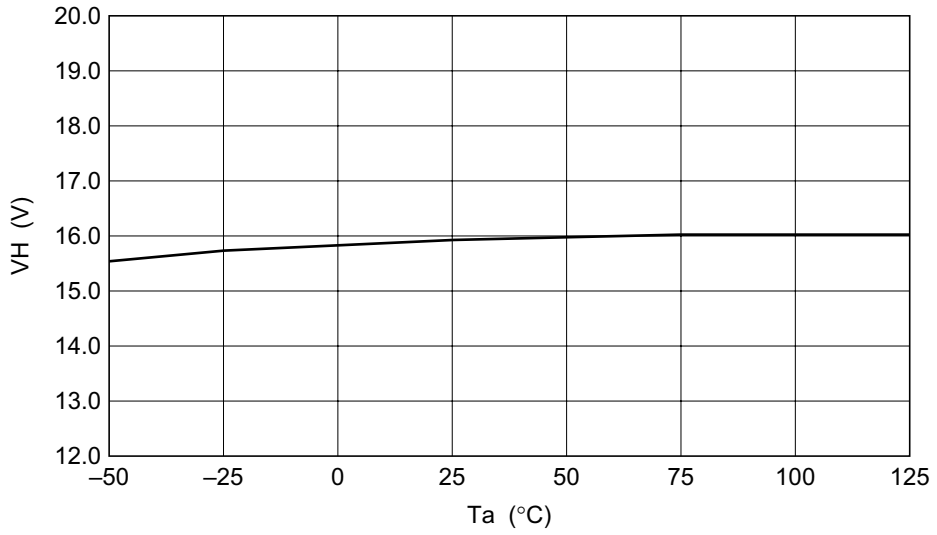

### UVL Shutdown Voltage vs. Ambient Temperature Characteristics

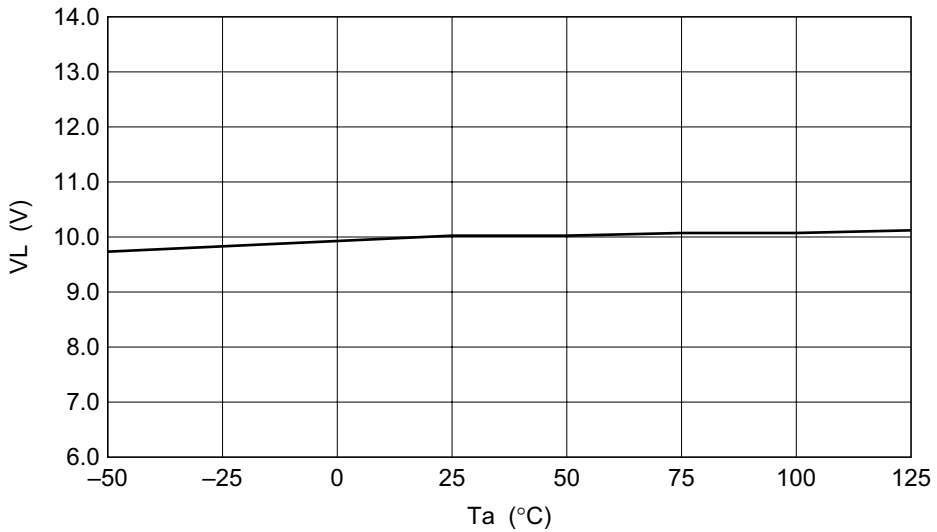

Application Circuit Example

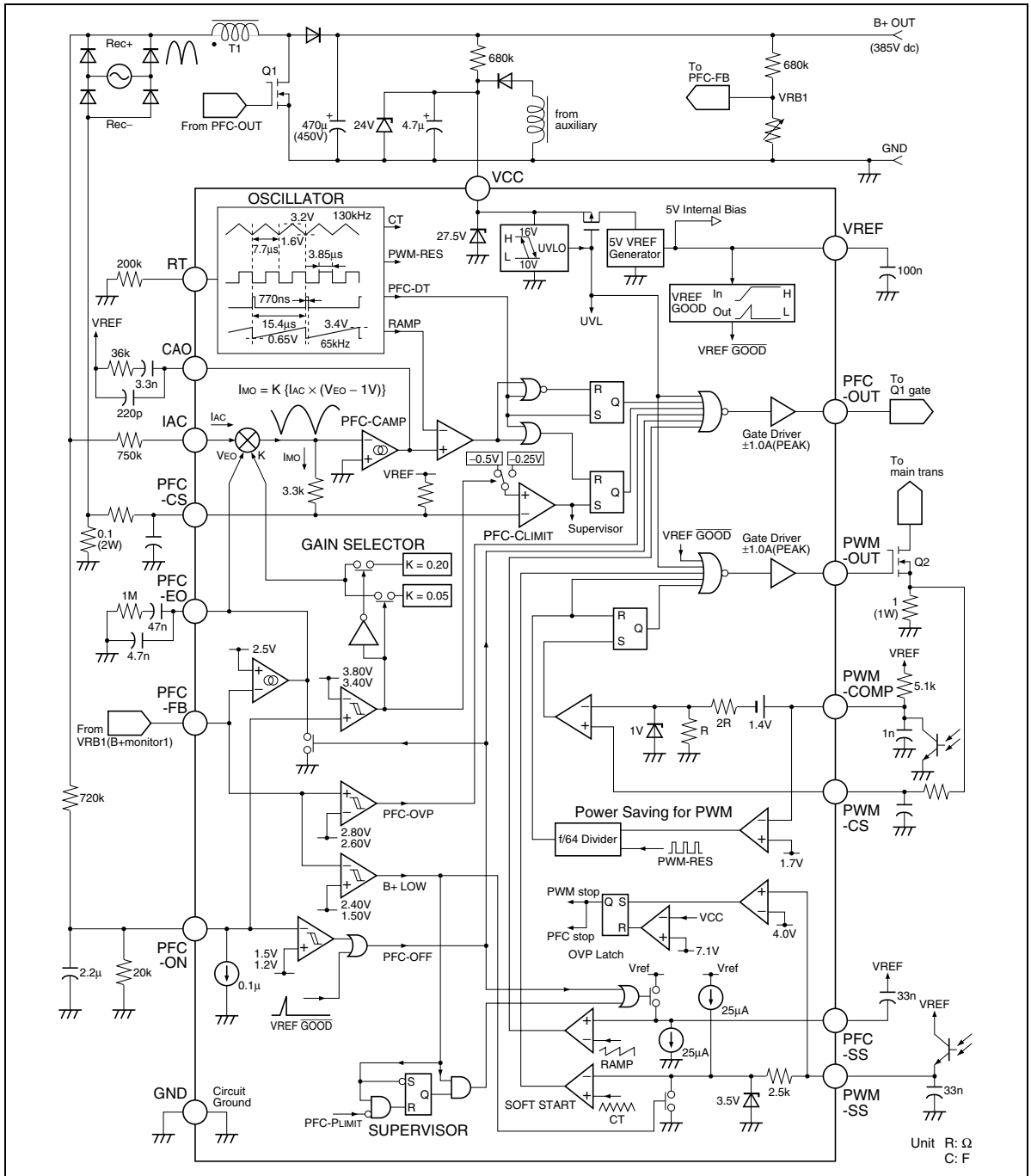

## Package Dimensions

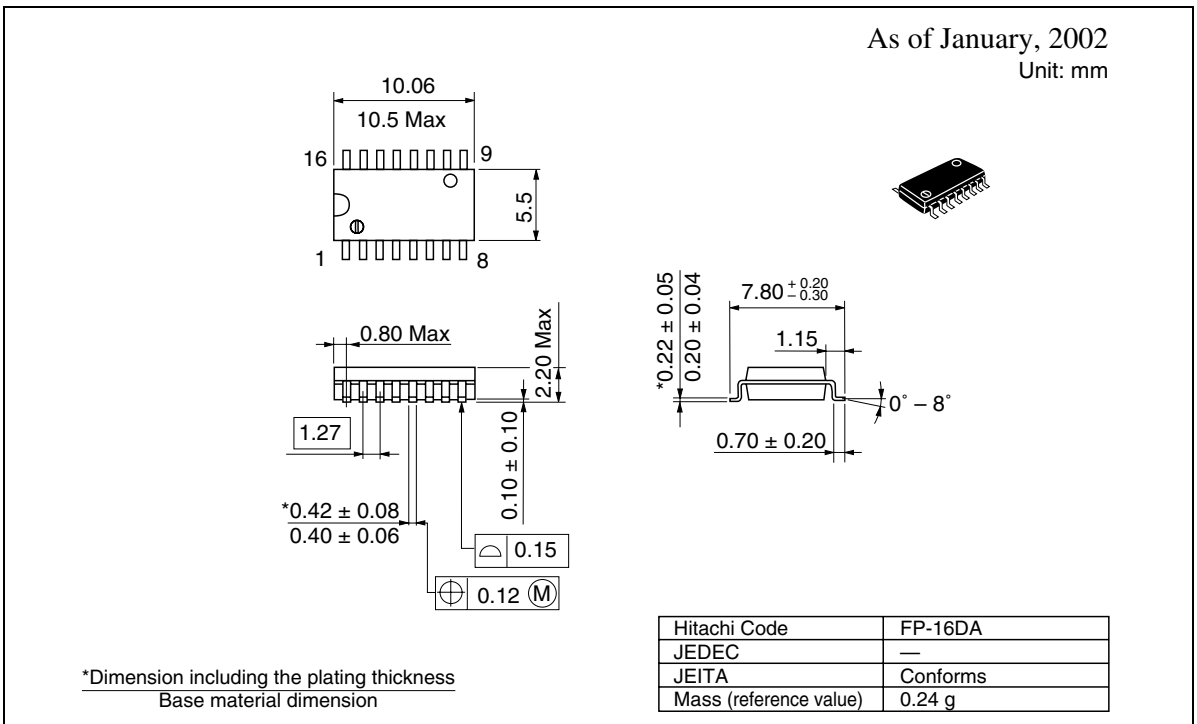
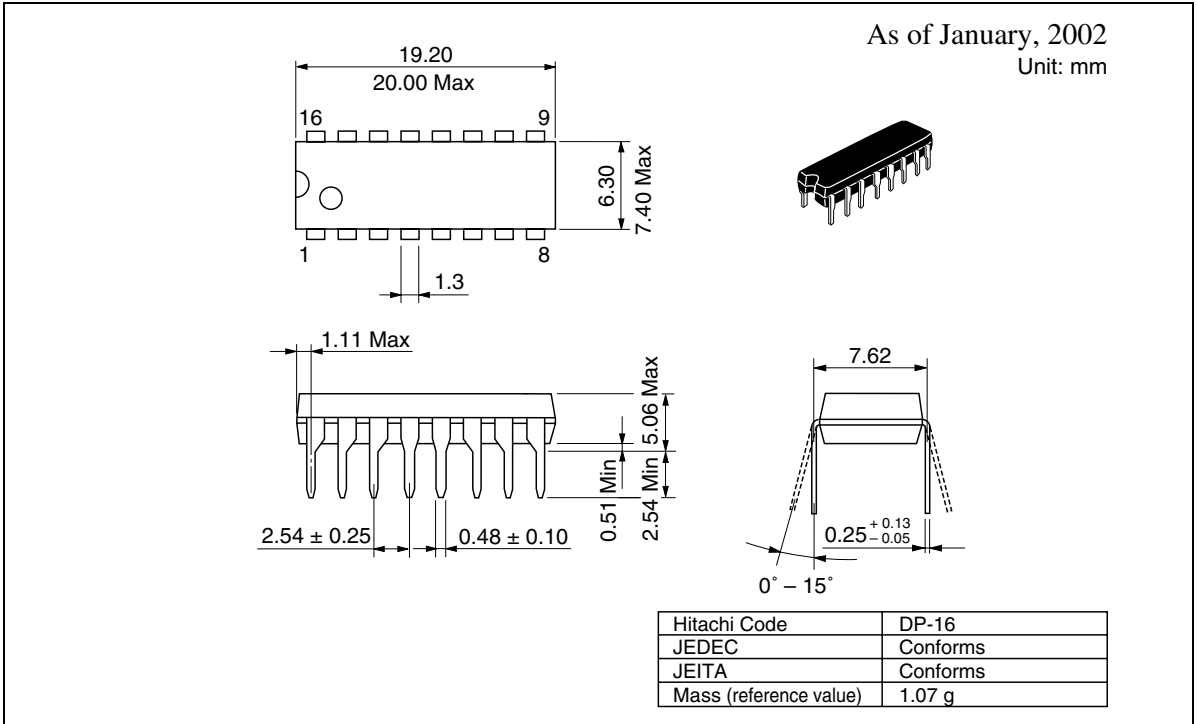

## Disclaimer

1. Hitachi neither warrants nor grants licenses of any rights of Hitachi's or any third party's patent, copyright, trademark, or other intellectual property rights for information contained in this document. Hitachi bears no responsibility for problems that may arise with third party's rights, including intellectual property rights, in connection with use of the information contained in this document.
2. Products and product specifications may be subject to change without notice. Confirm that you have received the latest product standards or specifications before final design, purchase or use.
3. Hitachi makes every attempt to ensure that its products are of high quality and reliability. However, contact Hitachi's sales office before using the product in an application that demands especially high quality and reliability or where its failure or malfunction may directly threaten human life or cause risk of bodily injury, such as aerospace, aeronautics, nuclear power, combustion control, transportation, traffic, safety equipment or medical equipment for life support.
4. Design your application so that the product is used within the ranges guaranteed by Hitachi particularly for maximum rating, operating supply voltage range, heat radiation characteristics, installation conditions and other characteristics. Hitachi bears no responsibility for failure or damage when used beyond the guaranteed ranges. Even within the guaranteed ranges, consider normally foreseeable failure rates or failure modes in semiconductor devices and employ systemic measures such as fail-safes, so that the equipment incorporating Hitachi product does not cause bodily injury, fire or other consequential damage due to operation of the Hitachi product.
5. This product is not designed to be radiation resistant.
6. No one is permitted to reproduce or duplicate, in any form, the whole or part of this document without written approval from Hitachi.
7. Contact Hitachi's sales office for any questions regarding this document or Hitachi semiconductor products.

## Sales Offices

# HITACHI

### Hitachi, Ltd.

Semiconductor & Integrated Circuits  
Nippon Bldg., 2-6-2, Ohte-machi, Chiyoda-ku, Tokyo 100-0004, Japan  
Tel: <03> 3270-2111 Fax: <03> 3270-5109

URL <http://www.hitachisemiconductor.com/>

### For further information write to:

Hitachi Semiconductor  
(America) Inc.  
179 East Tasman Drive  
San Jose, CA 95134  
Tel: <1> (408) 433-1990  
Fax: <1> (408) 433-0223

Hitachi Europe Ltd.  
Electronic Components Group  
Whitebrook Park  
Lower Cookham Road  
Maidenhead  
Berkshire SL6 8YA, United Kingdom  
Tel: <44> (1628) 585000  
Fax: <44> (1628) 585200

Hitachi Europe GmbH  
Electronic Components Group  
Dornacher Straße 3  
D-85622 Feldkirchen  
Postfach 201, D-85619 Feldkirchen  
Germany  
Tel: <49> (89) 9 9180-0  
Fax: <49> (89) 9 29 30 00

Hitachi Asia Ltd.  
Hitachi Tower  
16 Collyer Quay #20-00  
Singapore 049318  
Tel: <65>-6538-6533/6538-8577  
Fax: <65>-6538-6933/6538-3877  
URL: <http://semiconductor.hitachi.com.sg>

Hitachi Asia Ltd.  
(Taipei Branch Office)  
4/F, No. 167, Tun Hwa North Road  
Hung-Kuo Building  
Taipei (105), Taiwan  
Tel: <886>-(2)-2718-3666  
Fax: <886>-(2)-2718-8180  
Telex: 23222 HAS-TP  
URL: <http://www.hitachi.com.tw>

Hitachi Asia (Hong Kong) Ltd.  
Group III (Electronic Components)  
7/F., North Tower  
World Finance Centre,  
Harbour City, Canton Road  
Tsim Sha Tsui, Kowloon Hong Kong  
Tel: <852>-2735-9218  
Fax: <852>-2730-0281  
URL: <http://semiconductor.hitachi.com.hk>

Copyright © Hitachi, Ltd., 2002. All rights reserved. Printed in Japan.  
Colophon 6.0



LittleDiode supplies new, hard to find or obsolete electronic components and semiconductors all over the world.

With over two million different components listed you are sure to find the part you need.

Feel free to visit us today at our online store:

[LittleDiode.com](http://LittleDiode.com)

Looking forward to providing you with the best possible service.