

**NOT RECOMMENDED FOR NEW DESIGNS
NO RECOMMENDED REPLACEMENT
Call Central Applications 1-888-INTERSIL
or www.intersil.com/tsc**

50MHz, Selectable, Four Channel Video Operational Amplifier

The HA-2444 is a channel-selectable video op amp consisting of four differential inputs, a single-ended output, and digital control circuitry allowing two digital inputs to activate one of the four differential inputs. The HA-2444 also includes a high impedance output state allowing the outputs of multiple HA-2444s to be wire-OR'd. Functionally, the HA-2444 is equivalent to four wideband video op amps and a wideband multiplexer.

Unlike similar competitor devices, the HA-2444 is not restricted to multiplexing. Any op amp configuration can be used with any of the inputs. Signal amplification, addition, integration, and more can be put under digital control with broadcast quality performance.

The key video parameters of the HA-2444 have been optimized without compromising DC performance. Gain Flatness to 10MHz is only 0.1dB. Differential gain and phase are typically 0.03% and 0.03 degrees, respectively. Laser trimming allows offset voltages in the 4.0mV range and a unique common current source design assures minimal channel-to-channel mismatch, while maintaining 60dB of crosstalk rejection at 5MHz. Open loop gain of 76dB and low input offset and bias currents enhance the performance of this versatile device.

For information about military grade devices, please refer to the HA-2444/883 data sheet.

Pinout

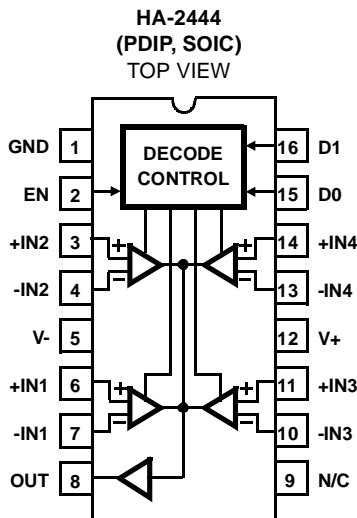

Features

- Digital Selection of Input Channel
- Unity Gain Stability
- Gain Flatness to 10MHz. 0.1dB
- Differential Gain 0.03%
- Differential Phase 0.03 Degrees
- Fast Channel Selection 60ns
- Crosstalk Rejection 60dB

Applications

- Video Multiplexer
- Programmable Gain Amplifier
- Special Effects Processors
- Video Distribution Systems
- Heads-up/Night Vision Displays
- Medical Imaging Systems
- Radar Video

Ordering Information

PART NUMBER	TEMP. RANGE (°C)	PACKAGE	PKG. NO.
HA3-2444-5	0 to 75	16 Ld PDIP	E16.3
HA9P2444-5	0 to 75	16 Ld SOIC	M16.3

Truth Table

EN	D1	D0	SELECTED CHANNEL
H	L	L	1
H	L	H	2
H	H	L	3
H	H	H	4
L	X	X	NONE-OUT is set to a high impedance state.

L = Low State (0.8V Max)
H = High State (2.4V Min)
X = Don't Care

Absolute Maximum Ratings

Supply Voltage Between V+ and V- Terminals 35V (±17.5V)
 Differential Input Voltage 6V
 Input Voltage ±V_S
 Digital Input Voltage GND +7.5V to GND -0.5V
 Peak (Short Duration) Output Current ±40mA

Operating Conditions

Temperature Range
 HA-2444-5 0°C to 75°C

CAUTION: Stresses above those listed in "Absolute Maximum Ratings" may cause permanent damage to the device. This is a stress only rating and operation of the device at these or any other conditions above those indicated in the operational sections of this specification is not implied.

NOTE:

1. θ_{JA} is measured with the component mounted on an evaluation PC board in free air.

Thermal Information

Thermal Resistance (Typical, Note 1) θ_{JA} (°C/W)
 PDIP Package 80
 SOIC Package 96
 Maximum Junction Temperature (Die Only) 175°C
 Maximum Junction Temperature (Plastic Package) 150°C
 Maximum Storage Temperature Range -65°C to 150°C
 Maximum Lead Temperature (Soldering 10s) 300°C
 (SOIC - Lead Tips Only)

Electrical Specifications $V_S = \pm 15V, R_L = 1k\Omega, C_L \leq 10pF, V_{IL} = 0.8V, V_{IH} = 2.4V$. Unless Otherwise Specified
 Specifications Apply to All Channels

PARAMETER	TEST CONDITIONS	TEMP. (°C)	HA-2444-5			UNITS
			MIN	TYP	MAX	
INPUT CHARACTERISTICS						
Input Offset Voltage		25	-	4	7	mV
		Full	-	-	15	mV
Average Input Offset Voltage Drift		Full	-	10	-	µV/°C
Channel to Channel Offset Voltage Mismatch		25	-	-	5	mV
		Full	-	-	8	mV
Input Bias Current		25	-	9	15	µA
		Full	-	-	20	µA
Average Input Bias Current Drift		Full	-	0.04	-	µA/°C
Input Offset Current		25	-	2	4	µA
		Full	-	-	6	µA
Average Input Offset Current Drift		Full	-	10	-	nA/°C
Common Mode Range		Full	-	±11.5	-	V
Differential Input Resistance (Note 2)		25	50	90	-	kΩ
Differential Input Capacitance		25	-	3	-	pF
Input Noise Voltage Density	f = 1000Hz	25	-	26	-	nV/√Hz
Input Noise Current Density	f = 1000Hz	25	-	4	-	pA/√Hz
TRANSFER CHARACTERISTICS						
Large Signal Voltage Gain	V _{OUT} = ±5V	25	71	76	-	dB
		Full	68	-	-	dB
Common Mode Rejection Ratio	V _{CM} = ±5V	Full	70	80	-	dB
Minimum Stable Gain		25	+1	-	-	V/V
Unity Gain Bandwidth	A _V = +1, V _{OUT} = ±100mV	25	-	45	-	MHz
Gain Bandwidth Product	V _{OUT} = ±100mV	25	-	50	-	MHz
OUTPUT CHARACTERISTICS						
Output Voltage Swing	R _L = 1kΩ	Full	±10	±11	-	V
Output Voltage Swing (Note 2)	R _L = 75Ω	25	±2	-	-	V
Full Power Bandwidth (Note 3)		Full	3.8	5.1	-	MHz
Output Current (Note 12)		Full	±25	-	-	mA
Disabled Output Current (Note 13)		Full	-	-	860	µA
Output Resistance		25	-	20	-	Ω

HA-2444

Electrical Specifications $V_S = \pm 15V$, $R_L = 1k\Omega$, $C_L \leq 10pF$, $V_{IL} = 0.8V$, $V_{IH} = 2.4V$. Unless Otherwise Specified
Specifications Apply to All Channels **(Continued)**

PARAMETER	TEST CONDITIONS	TEMP. (°C)	HA-2444-5			UNITS
			MIN	TYP	MAX	
TRANSIENT RESPONSE						
Rise Time (Note 4)	$A_V = +1$	25	-	7	-	ns
Overshoot (Note 4)	$A_V = +1$	25	-	10	-	%
Slew Rate (Note 6)	$A_V = +1$	Full	120	160	-	V/ μ s
Settling Time		25	-	120	-	ns
SWITCHING CHARACTERISTICS						
Channel Select Time	Note 7	0 to 85	-	60	100	ns
		-40 to 0	-	80	125	ns
Output Enable Time	Note 8	Full	-	40	100	ns
Digital Input Voltages	V_{IH}	Full	2.4	-	-	V
	V_{IL}	Full	-	-	0.8	V
D0/D1 Input Current	$V_{IL} = 0.0V$	Full	-	0.7	1	mA
	$V_{IH} = 5.0V$	Full	-	-	1.2	μ A
EN Input Current	$V_{IL} = 0.0V$	Full	-	-	50	μ A
	$V_{IH} = 5.0V$	Full	-	-	1.2	μ A
Crosstalk Rejection	Note 9	25	-	60	-	dB
VIDEO PARAMETERS						
Differential Phase	Note 11	25	-	0.03	-	Degrees
Differential Gain	Note 11	25	-	0.03	-	%
Gain Flatness (Note 10)	10MHz, $A_V = +1$	25	-	0.1	-	dB
Chrominance to Luminance Gain	Note 11	25	-	0.1	-	dB
Chrominance to Luminance Delay	Note 11	25	-	7	-	ns
POWER SUPPLY						
I_{CC}		Full	-	20	25	mA
I_{EE}		Full	-	20	25	mA
Supply Current (Output Disabled)	Note 14	Full	-	-	10	mA
PSRR	$V_S = \pm 15V$ to $\pm 20V$	Full	65	80	-	dB
Supply Voltage Range			± 8.5	-	± 17.0	V

NOTES:

- These parameters are not tested. The limits are guaranteed based on lab characterization and reflect lot to lot variation.
- Full Power Bandwidth is calculated by: $FPBW = \frac{\text{Slew Rate}}{2\pi V_{PEAK}}$; $V_{PEAK} = 5V$.
- $V_{OUT} = 0$ to $\pm 200mV$.
- Settling time to 0.1% with a 10V step. Specified with the channel pre-selected and the output stage enabled. $A_V = -1$.
- $V_{OUT} = -5V$ to $+5V$ or $+5V$ to $-5V$.
- The time required for an enabled HA-2444 to switch from one input channel to another. Measured from the 50% point of the digital input to 50% of the output. $A_V = +1$ for all channels. V_{OUT} switches from 0V to 5V.
- The time required to enable the output with a channel preselected. Measured from the 50% point of the Enable input to 4V on the output. $A_V = +1$ for all channels. $V_{IN} = 5V$ for the selected channel.
- $V_{IN} = 5V_{P-P}$, $f = 5MHz$, for one of the 3 unselected channels. $V_{IN} = 0$ for the selected channel. $A_V = +1$ for all channels.
- $V_{IN} = 200mV_{RMS}$.
- Tested with a VM700A video tester using a NTC-7 Composite input signal.
- $V_{OUT} = \pm 10V$, $V_{EN} = 2.4V$, 50% Duty Cycle Max.
- $V_{OUT} = \pm 5V$, $V_{EN} = 0.8V$.
- Applies to I_{CC} and I_{EE} . $V_{OUT} = 0V$, $V_{EN} = 0.8V$.

Die Characteristics

DIE DIMENSIONS:

74 mils x 103 mils x 19 mils
1880µm x 2620µm x 483µm

METALLIZATION:

Type: Al, 1% Cu
Thickness: 16kÅ ±2kÅ

SUBSTRATE POTENTIAL (Powered Up):

V-

PASSIVATION:

Type: Nitride over Silox
Silox Thickness: 12kÅ ±2kÅ
Nitride Thickness: 3.5kÅ ±1.5kÅ

TRANSISTOR COUNT:

129

PROCESS:

Bipolar Dielectric Isolation

Metallization Mask Layout

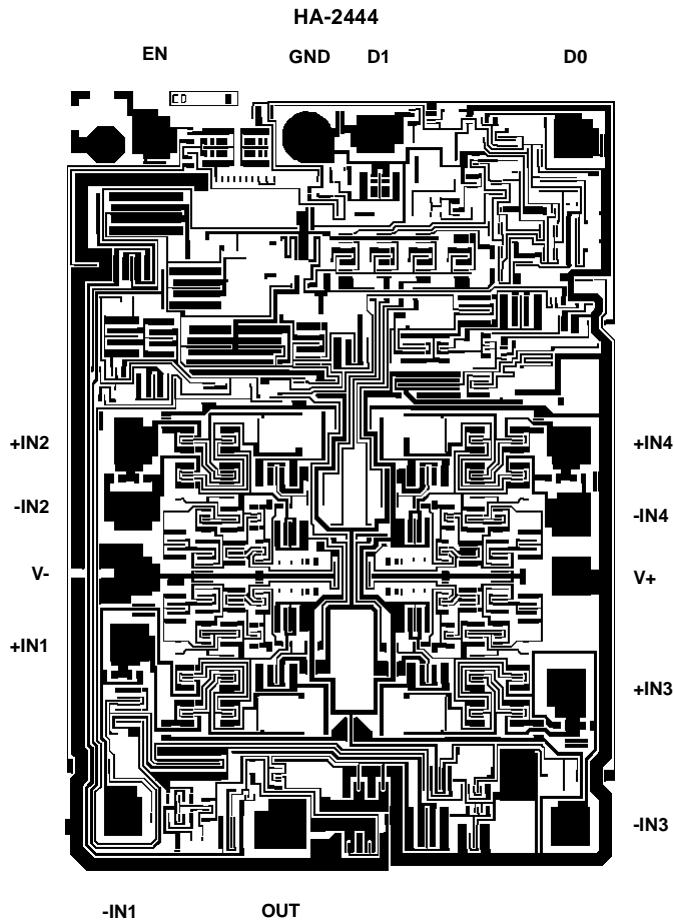

Dual-In-Line Plastic Packages (PDIP)

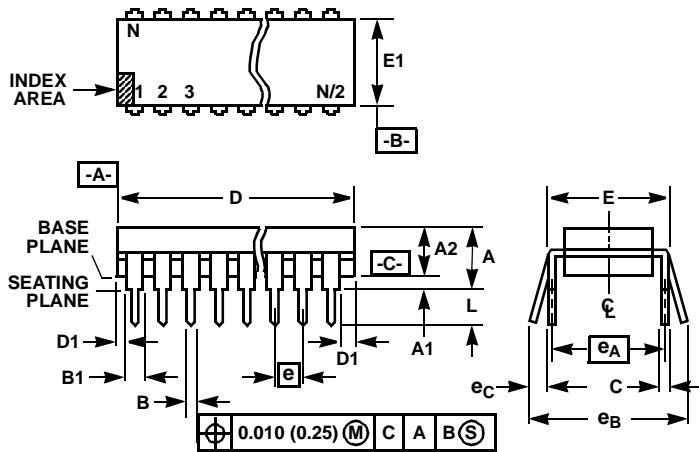

NOTES:

- Controlling Dimensions: INCH. In case of conflict between English and Metric dimensions, the inch dimensions control.
- Dimensioning and tolerancing per ANSI Y14.5M-1982.
- Symbols are defined in the "MO Series Symbol List" in Section 2.2 of Publication No. 95.
- Dimensions A, A1 and L are measured with the package seated in JEDEC seating plane gauge GS-3.
- D, D1, and E1 dimensions do not include mold flash or protrusions. Mold flash or protrusions shall not exceed 0.010 inch (0.25mm).
- E and e_A are measured with the leads constrained to be perpendicular to datum $-C-$.
- e_B and e_C are measured at the lead tips with the leads unconstrained. e_C must be zero or greater.
- B1 maximum dimensions do not include dambar protrusions. Dambar protrusions shall not exceed 0.010 inch (0.25mm).
- N is the maximum number of terminal positions.
- Corner leads (1, N, N/2 and N/2 + 1) for E8.3, E16.3, E18.3, E28.3, E42.6 will have a B1 dimension of 0.030 - 0.045 inch (0.76 - 1.14mm).

E16.3 (JEDEC MS-001-BB ISSUE D)
16 LEAD DUAL-IN-LINE PLASTIC PACKAGE

SYMBOL	INCHES		MILLIMETERS		NOTES
	MIN	MAX	MIN	MAX	
A	-	0.210	-	5.33	4
A1	0.015	-	0.39	-	4
A2	0.115	0.195	2.93	4.95	-
B	0.014	0.022	0.356	0.558	-
B1	0.045	0.070	1.15	1.77	8, 10
C	0.008	0.014	0.204	0.355	-
D	0.735	0.775	18.66	19.68	5
D1	0.005	-	0.13	-	5
E	0.300	0.325	7.62	8.25	6
E1	0.240	0.280	6.10	7.11	5
e	0.100 BSC		2.54 BSC		-
e_A	0.300 BSC		7.62 BSC		6
e_B	-	0.430	-	10.92	7
L	0.115	0.150	2.93	3.81	4
N	16		16		9

Rev. 0 12/93

Small Outline Plastic Packages (SOIC)

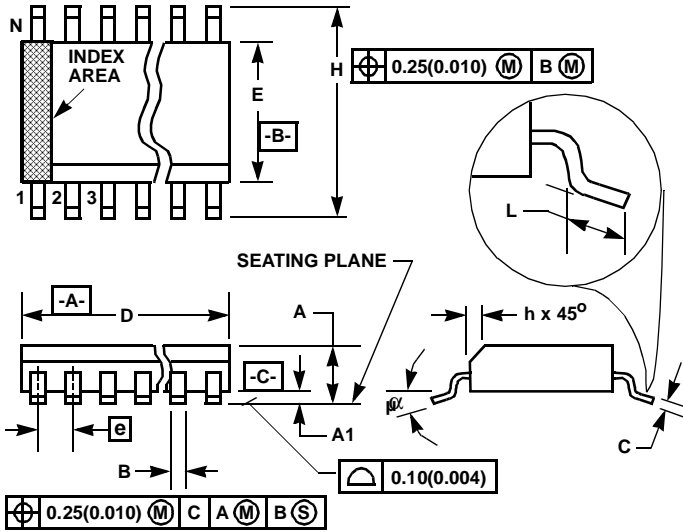

M16.3 (JEDEC MS-013-AA ISSUE C)
16 LEAD WIDE BODY SMALL OUTLINE PLASTIC PACKAGE

SYMBOL	INCHES		MILLIMETERS		NOTES
	MIN	MAX	MIN	MAX	
A	0.0926	0.1043	2.35	2.65	-
A1	0.0040	0.0118	0.10	0.30	-
B	0.013	0.0200	0.33	0.51	9
C	0.0091	0.0125	0.23	0.32	-
D	0.3977	0.4133	10.10	10.50	3
E	0.2914	0.2992	7.40	7.60	4
e	0.050 BSC		1.27 BSC		-
H	0.394	0.419	10.00	10.65	-
h	0.010	0.029	0.25	0.75	5
L	0.016	0.050	0.40	1.27	6
N	16		16		7
α	0°	8°	0°	8°	-

NOTES:

1. Symbols are defined in the "MO Series Symbol List" in Section 2.2 of Publication Number 95.
2. Dimensioning and tolerancing per ANSI Y14.5M-1982.
3. Dimension "D" does not include mold flash, protrusions or gate burrs. Mold flash, protrusion and gate burrs shall not exceed 0.15mm (0.006 inch) per side.
4. Dimension "E" does not include interlead flash or protrusions. Interlead flash and protrusions shall not exceed 0.25mm (0.010 inch) per side.
5. The chamfer on the body is optional. If it is not present, a visual index feature must be located within the crosshatched area.
6. "L" is the length of terminal for soldering to a substrate.
7. "N" is the number of terminal positions.
8. Terminal numbers are shown for reference only.
9. The lead width "B", as measured 0.36mm (0.014 inch) or greater above the seating plane, shall not exceed a maximum value of 0.61mm (0.024 inch)
10. Controlling dimension: MILLIMETER. Converted inch dimensions are not necessarily exact.

Rev. 0 12/93

All Intersil semiconductor products are manufactured, assembled and tested under **ISO9000** quality systems certification.

Intersil semiconductor products are sold by description only. Intersil Corporation reserves the right to make changes in circuit design and/or specifications at any time without notice. Accordingly, the reader is cautioned to verify that data sheets are current before placing orders. Information furnished by Intersil is believed to be accurate and reliable. However, no responsibility is assumed by Intersil or its subsidiaries for its use; nor for any infringements of patents or other rights of third parties which may result from its use. No license is granted by implication or otherwise under any patent or patent rights of Intersil or its subsidiaries.

For information regarding Intersil Corporation and its products, see web site www.intersil.com

This datasheet has been downloaded from:

www.DatasheetCatalog.com

Datasheets for electronic components.



LittleDiode supplies new, hard to find or obsolete electronic components and semiconductors all over the world.

With over two million different components listed you are sure to find the part you need.

Feel free to visit us today at our online store:

LittleDiode.com

Looking forward to providing you with the best possible service.