

400MHz, Fast Settling Operational Amplifier

The Intersil HA-2540 is a wideband, very high slew rate, monolithic operational amplifier featuring superior speed and bandwidth characteristics. Bipolar construction coupled with dielectric isolation allows this truly differential device to deliver outstanding performance in circuits where closed loop gain is 10 or greater. Additionally, the HA-2540 has a drive capability of $\pm 10V$ into a $1k\Omega$ load. Other desirable characteristics include low input voltage noise, low offset voltage, and fast settling time.

A $400V/\mu s$ slew rate ensures high performance in video and pulse amplification circuits, while the 400MHz gain-bandwidth product is ideally suited for wideband signal amplification. A settling time of 140ns also makes the HA-2540 an excellent selection for high speed Data Acquisition Systems.

Refer to Application Note AN541 and Application Note AN556 for more information on High Speed Op Amp applications. HA-2540/883 MIL-STD-883 data sheet is available on request.

For a lower power version of this product, please see the HA-2850 datasheet.

Pinout

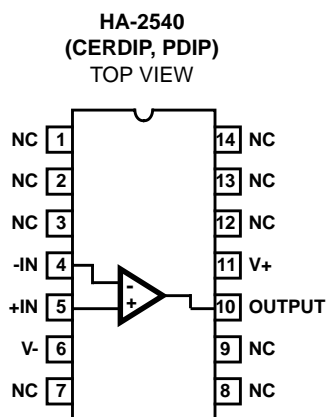

Features

- Very High Slew Rate $400V/\mu s$
- Fast Settling Time. 140ns
- Wide Gain Bandwidth ($A_V \geq 10$) 400MHz
- Power Bandwidth 6MHz
- Low Offset Voltage 8mV
- Input Voltage Noise $6nV/\sqrt{Hz}$
- Output Voltage Swing. $\pm 10V$
- Monolithic Bipolar Construction

Applications

- Pulse and Video Amplifiers
- Wideband Amplifiers
- High Speed Sample-Hold Circuits
- Fast, Precise D/A Converters

Ordering Information

PART NUMBER	TEMP. RANGE (°C)	PACKAGE	PKG. NO.
HA1-2540-2	-55 to 125	14 Ld CERDIP	F14.3
HA1-2540-5	0 to 75	14 Ld CERDIP	F14.3
HA3-2540-5	0 to 75	14 Ld PDIP	E14.3
HA3-2540C-5	0 to 75	14 Ld PDIP	E14.3

HA-2540

Absolute Maximum Ratings

Voltage Between V+ and V- Terminals 35V
 Differential Input Voltage 6V
 Output Current 33mA_{RMS} Continuous, 50mA_{PEAK}

Thermal Information

Thermal Resistance (Typical, Note 2) θ_{JA} (°C/W) θ_{JC} (°C/W)
 CERDIP Package 75 20
 PDIP Package 107 N/A
 Maximum Internal Power Dissipation (Note 1)
 Maximum Junction Temperature (Ceramic Package) 175°C
 Maximum Junction Temperature (Plastic Package) 150°C
 Maximum Storage Temperature Range -65°C to 150°C
 Maximum Lead Temperature (Soldering 10s) 300°C

Operating Conditions

Temperature Range
 HA-2540-2 -55°C to 125°C
 HA-2540/2540C-5 0°C to 75°C

CAUTION: Stresses above those listed in "Absolute Maximum Ratings" may cause permanent damage to the device. This is a stress only rating and operation of the device at these or any other conditions above those indicated in the operational sections of this specification is not implied.

NOTES:

1. Maximum power dissipation with load conditions must be designed to maintain the maximum junction temperature below 175°C for the ceramic package, and below 150°C for the plastic package. By using Application Note AN556 on Safe Operating Area Equations, along with the thermal resistances, proper load conditions can be determined. Heat sinking is recommended above 75°C.
2. θ_{JA} is measured with the component mounted on an evaluation PC board in free air.

Electrical Specifications $V_{SUPPLY} = \pm 15V$, $R_L = 1k\Omega$, $C_L < 10pF$, Unless Otherwise Specified

PARAMETER	TEMP (°C)	HA-2540-2			HA-2540-5			HA-2540C-5			UNITS
		MIN	TYP	MAX	MIN	TYP	MAX	MIN	TYP	MAX	
INPUT CHARACTERISTICS											
Offset Voltage	25	-	8	10	-	8	15	-	8	15	mV
	Full	-	13	15	-	13	20	-	13	20	mV
Average Offset Voltage Drift	Full	-	20	-	-	20	-	-	20	-	$\mu V/^\circ C$
Bias Current	25	-	5	20	-	5	20	-	5	20	μA
	Full	-	-	25	-	-	25	-	-	25	μA
Offset Current	25	-	1	6	-	1	6	-	1	6	μA
	Full	-	-	8	-	-	8	-	-	8	μA
Input Resistance	25	-	10	-	-	10	-	-	10	-	k Ω
Input Capacitance	25	-	1	-	-	1	-	-	1	-	pF
Common Mode Range	Full	± 10	-	-	± 10	-	-	± 10	-	-	V
Input Noise Current (f = 1kHz, $R_{SOURCE} = 0\Omega$)	25	-	6	-	-	6	-	-	6	-	pA/ \sqrt{Hz}
Input Noise Voltage (f = 1kHz, $R_{SOURCE} = 0\Omega$)	25	-	6	-	-	6	-	-	6	-	nV/ \sqrt{Hz}
TRANSFER CHARACTERISTICS											
Large Signal Voltage Gain (Note 3)	25	10	15	-	10	15	-	7	10	-	kV/V
	Full	5	-	-	5	-	-	5	-	-	kV/V
Common-Mode Rejection Ratio (Note 4)	Full	60	72	-	60	72	-	60	72	-	dB
Minimum Stable Gain	25	10	-	-	10	-	-	10	-	-	V/V
Gain Bandwidth Product (Notes 5, 6)	25	-	400	-	-	400	-	-	400	-	MHz
OUTPUT CHARACTERISTICS											
Output Voltage Swing (Notes 3, 10)	Full	± 10	-	-	± 10	-	-	± 10	-	-	V
Output Current (Note 3)	25	± 10	± 20	-	± 10	± 20	-	± 10	± 20	-	mA
Output Resistance	25	-	30	-	-	30	-	-	30	-	Ω
Full Power Bandwidth (Notes 3, 7)	25	5.5	6	-	5.5	6	-	5.5	6	-	MHz
TRANSIENT RESPONSE (Note 8)											
Rise Time	25	-	14	-	-	14	-	-	14	-	ns
Overshoot	25	-	5	-	-	5	-	-	5	-	%
Slew Rate	25	320	400	-	320	400	-	320	400	-	V/ μs
Settling Time: 10V Step to 0.1%	25	-	140	-	-	140	-	-	140	-	ns

Electrical Specifications $V_{SUPPLY} = \pm 15V$, $R_L = 1k\Omega$, $C_L < 10pF$, Unless Otherwise Specified (Continued)

PARAMETER	TEMP (°C)	HA-2540-2			HA-2540-5			HA-2540C-5			UNITS
		MIN	TYP	MAX	MIN	TYP	MAX	MIN	TYP	MAX	
POWER REQUIREMENTS											
Supply Current	Full	-	20	25	-	20	25	-	20	25	mA
Power Supply Rejection Ratio (Note 9)	Full	60	70	-	60	70	-	60	70	-	dB

NOTES:

3. $R_L = 1k\Omega$, $V_O = \pm 10V$.
4. $V_{CM} = \pm 10V$.
5. $V_O = 90mV$.
6. $A_V = 10$.
7. Full power bandwidth guaranteed based on slew rate measurement using: $FPBW = \frac{\text{Slew Rate}}{2\pi V_{PEAK}}$.
8. Refer to Test Circuits section of the data sheet.
9. $V_{SUPPLY} = +5V, -15V$ and $+15V, -5V$.
10. Guaranteed range for output voltage is $\pm 10V$. Functional operation outside of this range is not guaranteed.

Test Circuits and Waveforms

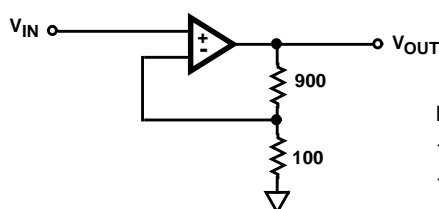

NOTES:

11. $A_V = +10$.
12. $C_L \leq 10pF$.

FIGURE 1. LARGE AND SMALL SIGNAL RESPONSE TEST CIRCUIT

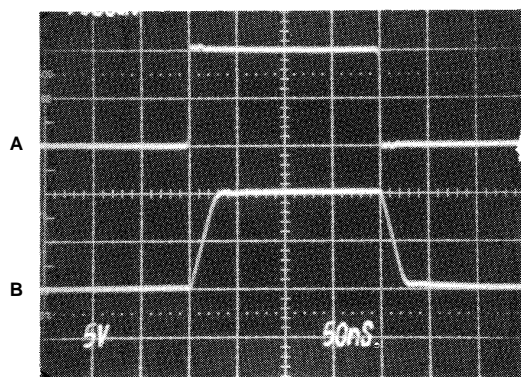

Vertical Scale: A = 0.5V/Div., B = 5.0V/Div.
Horizontal Scale: 50ns/Div.

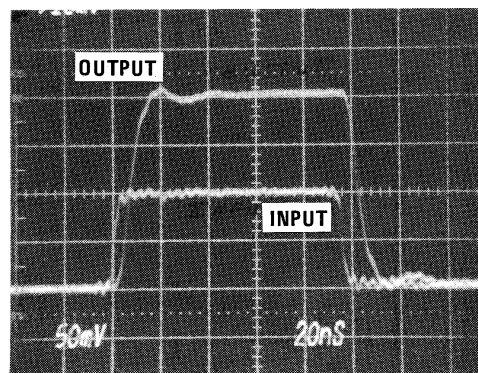

Vertical Scale: Input = 10mV/Div.; Output = 50mV/Div.
Horizontal Scale: 20ns/Div.

LARGE SIGNAL RESPONSE

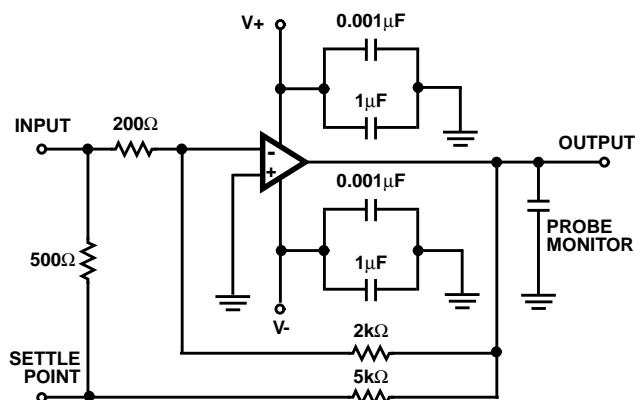

FIGURE 2. SETTLING TIME TEST CIRCUIT

SMALL SIGNAL RESPONSE

NOTES:

13. $A_V = -10$.
14. Load Capacitance should be less than 10pF. Turn on time delay typically 4ns.
15. It is recommended that resistors be carbon composition and the feedback and summing network ratios be matched to 0.1%.
16. SETTLE POINT (Summing Node) capacitance should be less than 10pF. For optimum settling time results, it is recommended that the test circuit be constructed directly onto the device pins. A Tektronix 568 Sampling Oscilloscope with S-3A sampling heads is recommended as a settle point monitor.

Schematic Diagram

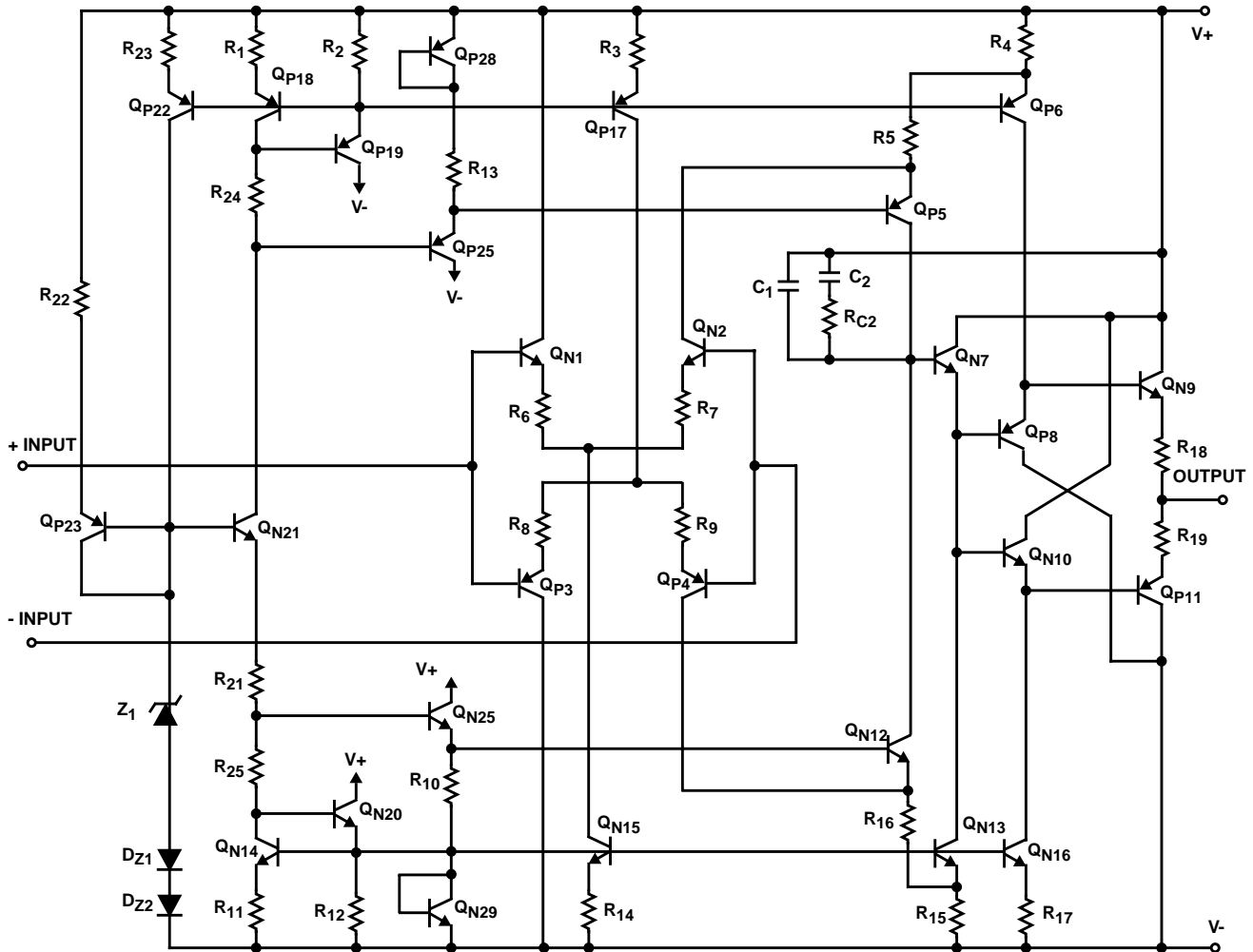

Typical Applications

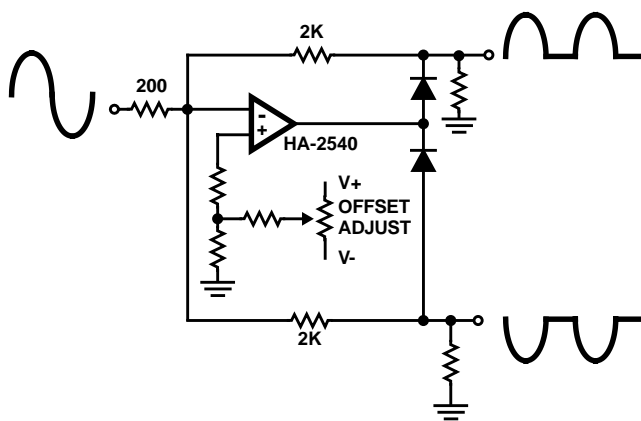

NOTE: With one HA-2540 and two low capacitance switching diodes, signals exceeding 10MHz can be separated. This circuit is most useful for full wave rectification, AM detectors or sync generation.

FIGURE 3. WIDEBAND SIGNAL SPLITTER

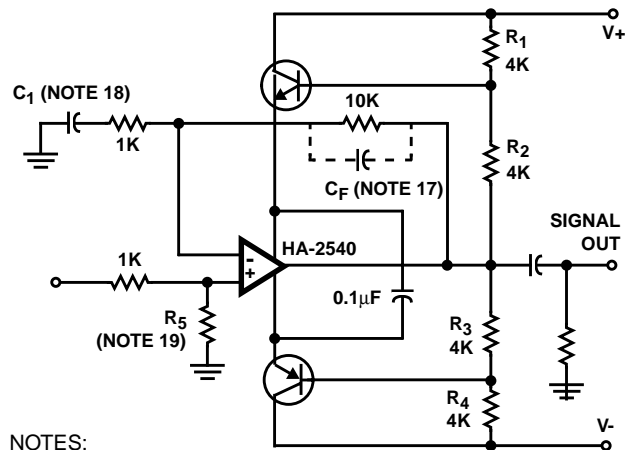

NOTES:

- 17. Used for experimental purposes. $C_F \cong 3pF$.
- 18. C_1 is optional ($0.001\mu F \rightarrow 0.01\mu F$ ceramic).
- 19. R_5 is optional and can be utilized to reduce input signal amplitude and/or balance input conditions. $R_5 = 500\Omega$ to $1k\Omega$.

FIGURE 4. BOOTSTRAPPING FOR MORE OUTPUT CURRENT AND VOLTAGE SWING

Refer to Application Note AN541 For Further Application Information.

Typical Performance Curves

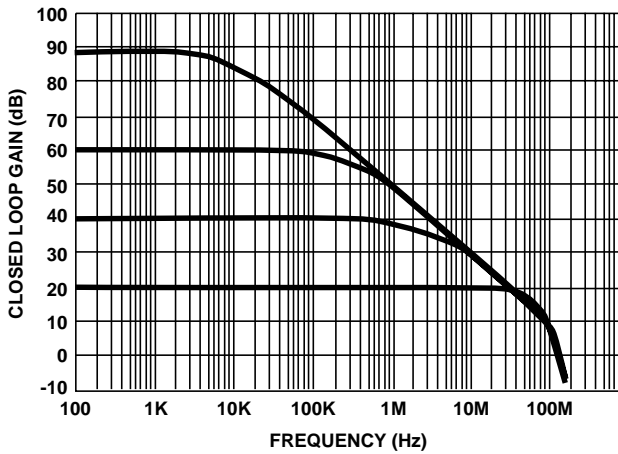

FIGURE 5. CLOSED LOOP FREQUENCY RESPONSE

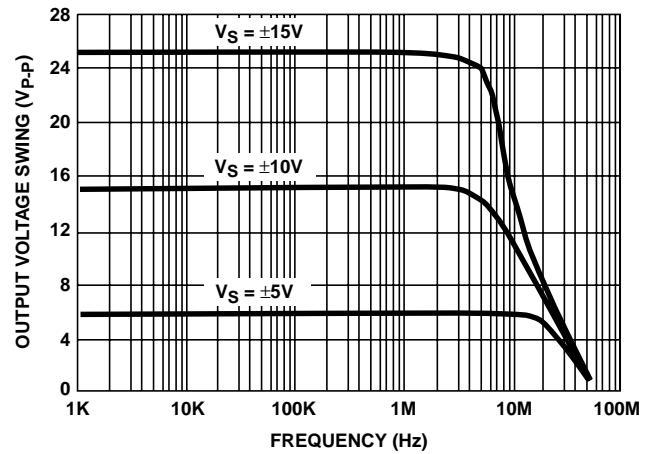

FIGURE 6. OUTPUT VOLTAGE SWING vs FREQUENCY

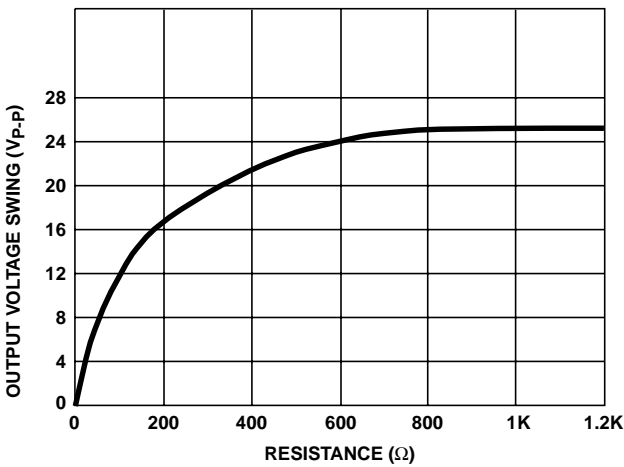

FIGURE 7. OUTPUT VOLTAGE SWING vs LOAD RESISTANCE

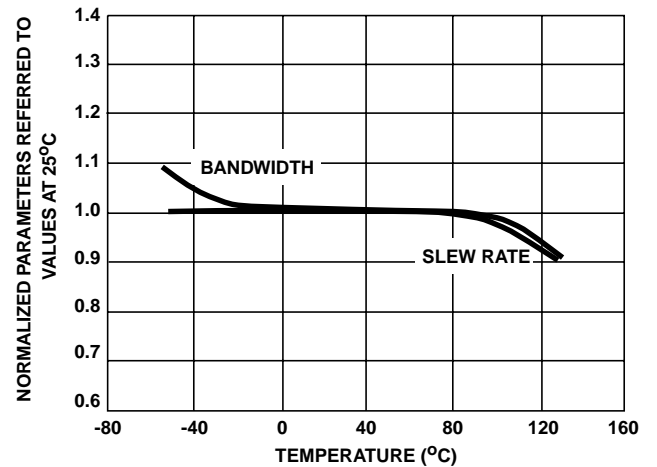

FIGURE 8. NORMALIZED AC PARAMETERS vs TEMPERATURE

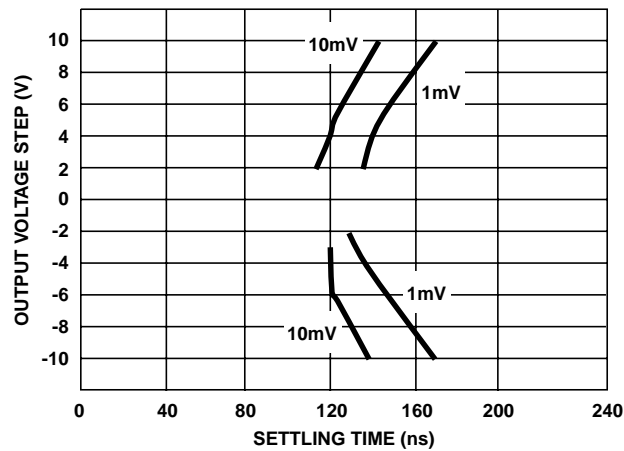

FIGURE 9. SETTLING TIME FOR VARIOUS OUTPUT STEP VOLTAGES

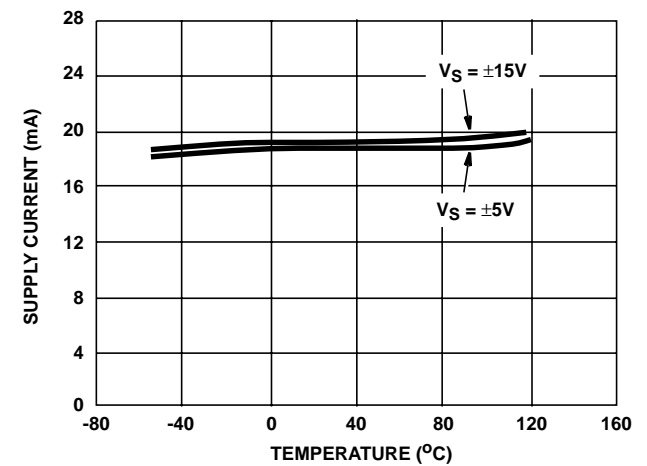

FIGURE 10. POWER SUPPLY CURRENT vs TEMPERATURE

Typical Performance Curves (Continued)

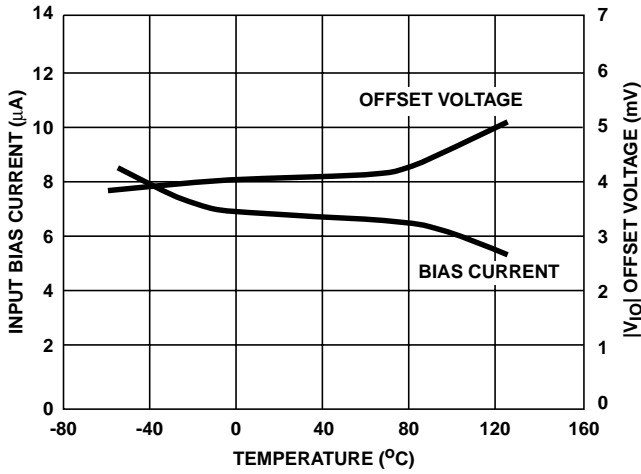

FIGURE 11. INPUT OFFSET VOLTAGE AND BIAS CURRENT vs TEMPERATURE

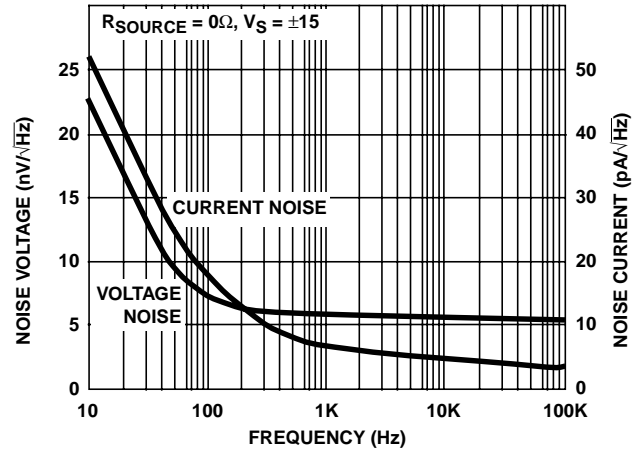

FIGURE 12. INPUT NOISE VOLTAGE AND NOISE CURRENT vs FREQUENCY

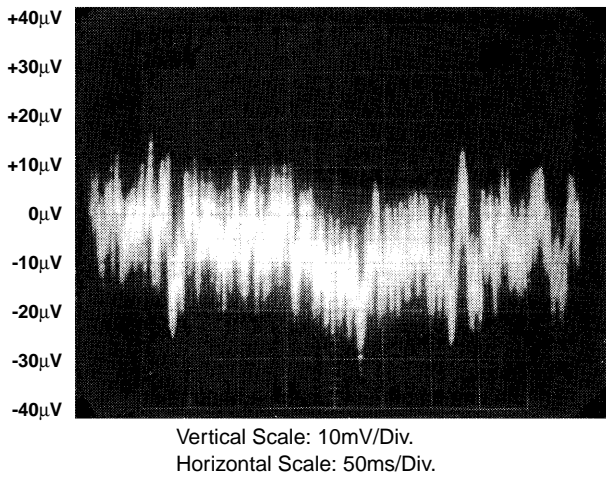

FIGURE 13. BROADBAND NOISE (0.1Hz TO 1MHz)

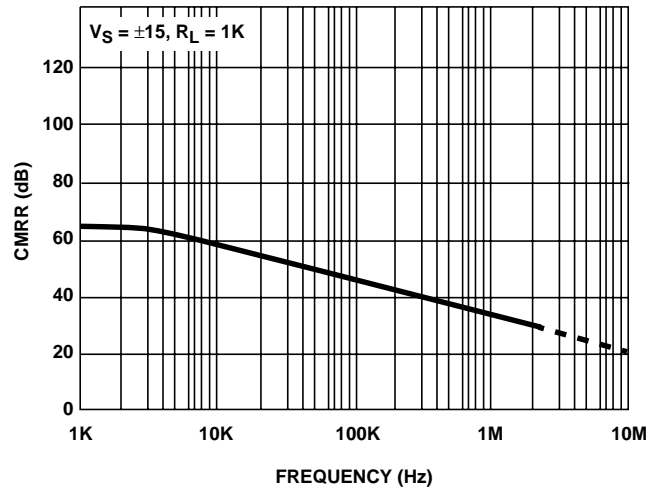

FIGURE 14. COMMON MODE REJECTION RATIO vs FREQUENCY

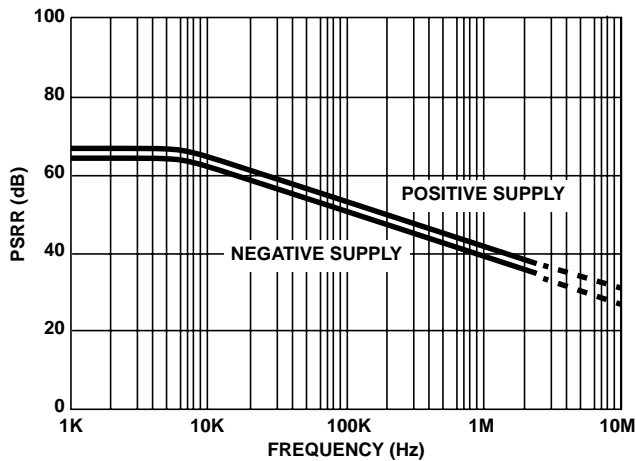

FIGURE 15. POWER SUPPLY REJECTION RATIO vs FREQUENCY

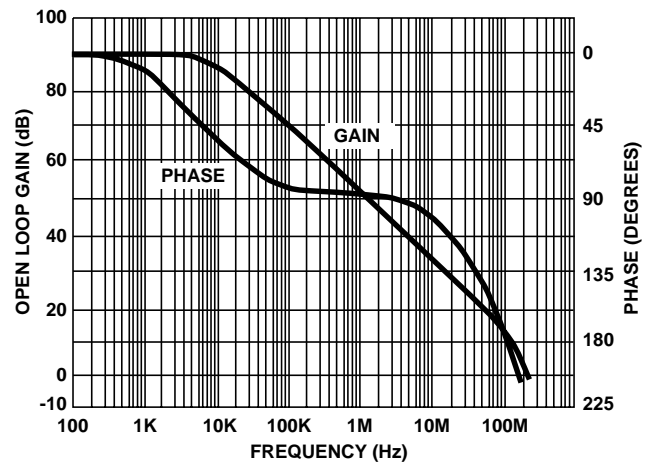

FIGURE 16. OPEN LOOP GAIN/PHASE vs FREQUENCY

Die Characteristics

HA-2540

DIE DIMENSIONS:

62 mils x 76 mils x 19 mils
1575 μm x 1930 μm x 483 μm

METALLIZATION:

Type: Al, 1% Cu
Thickness: 16k \AA \pm 2k \AA

PASSIVATION:

Type: Nitride (Si_3N_4) over Silox (SiO_2 , 5% Phos.)
Silox Thickness: 12k \AA \pm 2k \AA
Nitride Thickness: 3.5k \AA \pm 1.5k \AA

SUBSTRATE POTENTIAL (Powered Up):

V-

TRANSISTOR COUNT:

30

PROCESS:

Bipolar Dielectric Isolation

Metallization Mask Layout

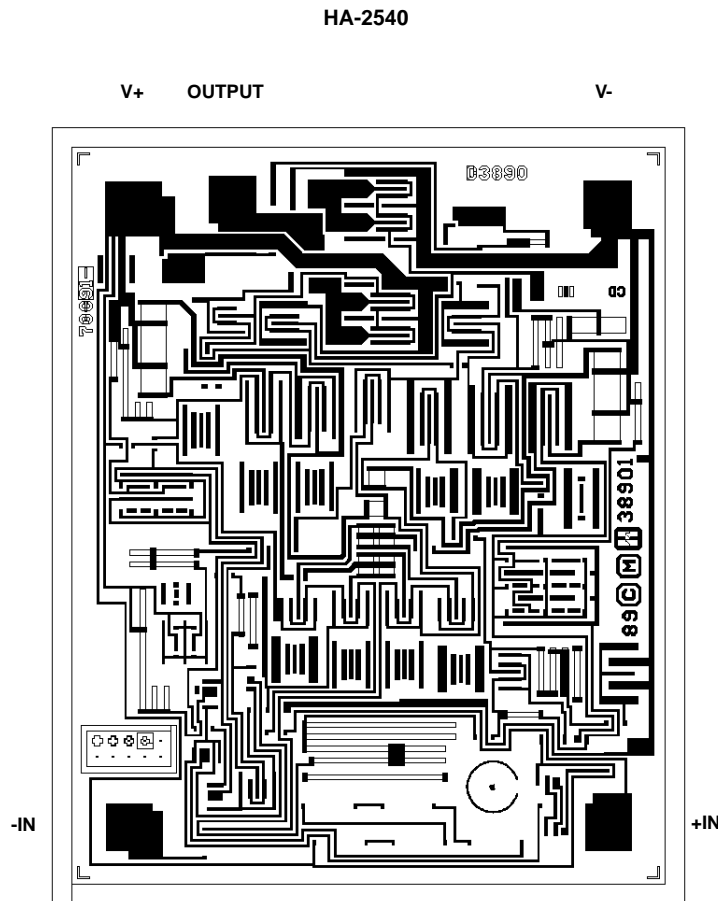

All Intersil semiconductor products are manufactured, assembled and tested under **ISO9000** quality systems certification.

Intersil semiconductor products are sold by description only. Intersil Corporation reserves the right to make changes in circuit design and/or specifications at any time without notice. Accordingly, the reader is cautioned to verify that data sheets are current before placing orders. Information furnished by Intersil is believed to be accurate and reliable. However, no responsibility is assumed by Intersil or its subsidiaries for its use; nor for any infringements of patents or other rights of third parties which may result from its use. No license is granted by implication or otherwise under any patent or patent rights of Intersil or its subsidiaries.

For information regarding Intersil Corporation and its products, see web site <http://www.intersil.com>

This datasheet has been downloaded from:

www.DatasheetCatalog.com

Datasheets for electronic components.



LittleDiode supplies new, hard to find or obsolete electronic components and semiconductors all over the world.

With over two million different components listed you are sure to find the part you need.

Feel free to visit us today at our online store:

LittleDiode.com

Looking forward to providing you with the best possible service.