

700ns, Low Distortion, Precision Sample and Hold Amplifier

The HA-5340 combines the advantages of two sample/hold architectures to create a new generation of monolithic sample/hold. High amplitude, high frequency signals can be sampled with very low distortion being introduced. The combination of exceptionally fast acquisition time and specified/characterized hold mode distortion is an industry first. Additionally, the AC performance is only minimally affected by additional hold capacitance.

To achieve this level of performance, the benefits of an integrating output stage have been combined with the advantages of a buffered hold capacitor. To the user this translates to a front-end stage that has high bandwidth due to charging only a small capacitive load and an output stage with constant pedestal error which can be nulled out using the offset adjust pins. Since the performance penalty for additional hold capacitance is low, the designer can further minimize pedestal error and droop rate without sacrificing speed.

Low distortion, fast acquisition, and low droop rate are the result, making the HA-5340 the obvious choice for high speed, high accuracy sampling systems. For a Military temperature range version request the HA-5340/883 data sheet.

Ordering Information

PART NUMBER	TEMP. RANGE (°C)	PACKAGE	PKG. NO.
HA3-5340-5	0 to 75	14 Ld PDIP	E14.3
HA9P5340-5	0 to 75	16 Ld SOIC	M16.3

Functional Diagram

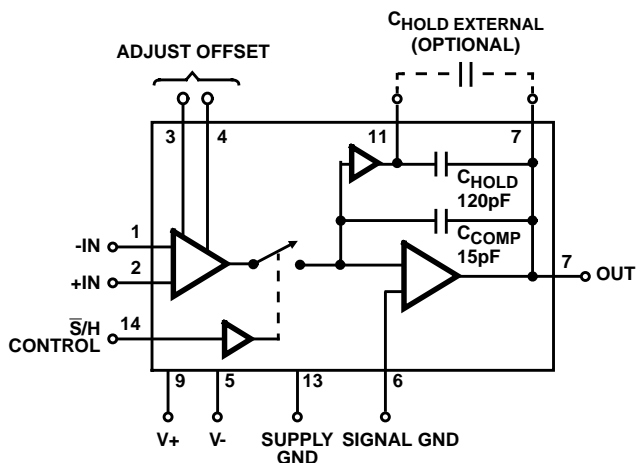

Features

- Fast Acquisition Time (0.01%)700ns
- Fast Hold Mode Settling Time (0.01%)200n
- Low Distortion (Hold Mode)-72dBc ($V_{IN} = 200\text{kHz}$, $f_S = 450\text{kHz}$, $5V_{P-P}$)
- Bandwidth Minimally Affected By External C_H
- Fully Differential Analog Inputs
- Built-In 135pF Hold Capacitor
- Pin Compatible with HA-5320

Applications

- High Bandwidth Precision Data Acquisition Systems
- Inertial Navigation and Guidance Systems
- Ultrasonics
- SONAR
- RADAR

Pinouts

HA-5340 (PDIP) TOP VIEW

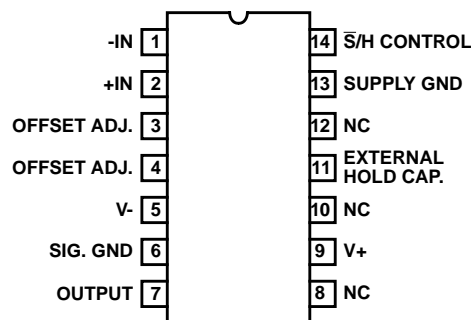

HA-5340 (SOIC) TOP VIEW

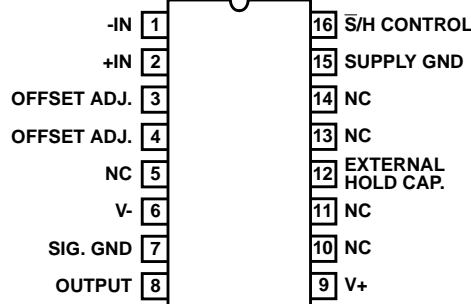

Absolute Maximum Ratings

Voltage Between V+ and V- Terminals	36V
Differential Input Voltage	24V
Digital Input Voltage	+8V, -6V
Output Current, Continuous	±20mA

Thermal Information

Thermal Resistance (Typical, Note 2)	θ_{JA} (°C/W)	θ_{JC} (°C/W)
PDIP Package	90	N/A
SOIC Package	95	N/A
Maximum Junction Temperature (Plastic Package, Note 1)	150°C	
Maximum Storage Temperature Range	-65°C to 150°C	
Maximum Lead Temperature (Soldering 10s)	300°C (SOIC - Lead Tips Only)	

Operating Conditions

Temperature Range	
HA-5340-5	0°C to 75°C
Supply Voltage Range (Typical)	±12V to ±18V

CAUTION: Stresses above those listed in "Absolute Maximum Ratings" may cause permanent damage to the device. This is a stress only rating and operation of the device at these or any other conditions above those indicated in the operational sections of this specification is not implied.

NOTES:

1. Maximum power dissipation must be designed to maintain the junction temperature below 150°C for the plastic packages.
2. θ_{JA} is measured with the component mounted on an evaluation PC board in free air.

Electrical Specifications $V_{SUPPLY} = \pm 15.0V$; $C_H = \text{Internal} = 135pF$; Digital Input: $V_{IL} = +0.8V$ (Sample), $V_{IH} = +2.0V$ (Hold). Non-Inverting Unity Gain Configuration (Output tied to -Input), $R_L = 2k\Omega$, $C_L = 60pF$, Unless Otherwise Specified

PARAMETER	TEST CONDITIONS	TEMP. (°C)	HA-5340-5			UNITS
			MIN	TYP	MAX	
INPUT CHARACTERISTICS						
Input Voltage Range		Full	-10	-	+10	V
Input Resistance (Note 3)		25	-	1	-	MΩ
Input Capacitance		25	-	-	3	pF
Input Offset Voltage		25	-	-	1.5	mV
		Full	-	-	3.0	mV
Offset Voltage Temperature Coefficient		Full	-	-	30	μV/°C
Bias Current		25	-	±70	-	nA
		Full	-	-	±350	nA
Offset Current		25	-	±50	-	nA
		Full	-	-	±350	nA
Common Mode Range		Full	-10	-	+10	V
CMRR	±10V, Note 4	25	-	83	-	dB
		Full	72	-	-	dB
TRANSFER CHARACTERISTICS						
Gain	DC	25	110	140	-	dB
Gain Bandwidth Product	C_H External = 0pF	Full	-	10	-	MHz
	C_H External = 100pF	Full	-	9.6	-	MHz
	C_H External = 1000pF	Full	-	6.7	-	MHz
TRANSIENT RESPONSE						
Rise Time	200mV Step	25	-	20	30	ns
Overshoot	200mV Step	25	-	35	50	%
Slew Rate	10V Step	25	40	60	-	V/μs
DIGITAL INPUT CHARACTERISTICS						
Input Voltage	V_{IH}	Full	2.0	-	-	V
	V_{IL}	Full	-	-	0.8	V
Input Current	$V_{IL} = 0V$	Full	-	7	40	μA
	$V_{IH} = 5V$	Full	-	4	40	μA

HA-5340

Electrical Specifications $V_{SUPPLY} = \pm 15.0V$; $C_H = \text{Internal} = 135pF$; Digital Input: $V_{IL} = +0.8V$ (Sample), $V_{IH} = +2.0V$ (Hold). Non-Inverting Unity Gain Configuration (Output tied to -Input), $R_L = 2k\Omega$, $C_L = 60pF$, Unless Otherwise Specified **(Continued)**

PARAMETER	TEST CONDITIONS	TEMP. (°C)	HA-5340-5			UNITS
			MIN	TYP	MAX	
OUTPUT CHARACTERISTICS						
Output Voltage		Full	-10	-	+10	V
Output Current		Full	-10	-	+10	mA
Full Power Bandwidth (Note 5)		Full	0.6	0.9	-	MHz
Output Resistance	Hold Mode	25	-	0.05	0.1	Ω
		Full	-	0.07	0.15	Ω
Total Output Noise DC to 10MHz	Sample Mode	25	-	325	400	μV_{RMS}
	Hold Mode	25	-	325	400	μV_{RMS}
DISTORTION CHARACTERISTICS						
SAMPLE MODE						
Signal to Noise Ratio (RMS Signal to RMS Noise)	$V_{IN} = 200kHz, 20V_{P-P}$	Full	-	115	-	dB
Total Harmonic Distortion	$V_{IN} = 200kHz, 5V_{P-P}$	Full	-90	-100	-	dBc
	$V_{IN} = 200kHz, 10V_{P-P}$	Full	-76	-82	-	dBc
	$V_{IN} = 200kHz, 20V_{P-P}$	Full	-70	-74	-	dBc
	$V_{IN} = 500kHz, 5V_{P-P}$	Full	-66	-75	-	dBc
Intermodulation Distortion	$V_{IN} = 10V_{P-P}, f_1 = 20kHz, f_2 = 21kHz$	Full	-78	-83	-	dBc
HOLD MODE (50% Duty Cycle S/H)						
Signal to Noise Ratio (RMS Signal to RMS Noise) $f_S = 450kHz$	$V_{IN} = 200kHz, 5V_{P-P}$	25	-	76	-	dB
	$V_{IN} = 200kHz, 10V_{P-P}$	25	-	76	-	dB
Total Harmonic Distortion $f_S = 450kHz$	$V_{IN} = 200kHz, 5V_{P-P}$	25	-	-72	-	dBc
	$V_{IN} = 200kHz, 10V_{P-P}$	25	-	-66	-	dBc
	$V_{IN} = 200kHz, 20V_{P-P}$	25	-	-56	-	dBc
$f_S = 450kHz$	$V_{IN} = 100kHz, 5V_{P-P}$	25	-	-84	-	dBc
	$V_{IN} = 100kHz, 10V_{P-P}$	25	-	-71	-	dBc
	$V_{IN} = 100kHz, 20V_{P-P}$	25	-	-61	-	dBc
$f_S = 2f_{IN}$ (Nyquist)	$V_{IN} = 20kHz, 5V_{P-P}$	25	-	-95	-	dBc
	$V_{IN} = 50kHz, 5V_{P-P}$	25	-	-91	-	dBc
	$V_{IN} = 100kHz, 5V_{P-P}$	25	-	-82	-	dBc
Intermodulation Distortion $f_S = 450kHz$	$V_{IN} = 10V_{P-P}$ ($f_1 = 20kHz, f_2 = 21kHz$)	25	-	-79	-	dBc
SAMPLE AND HOLD CHARACTERISTICS						
Acquisition Time	10V Step to 0.01%	25	-	700	-	ns
		Full	-	-	900	ns
	10V Step to 0.1%	25	-	430	600	ns
Droop Rate	$C_H = \text{Internal}$	25	-	0.1	-	$\mu V/\mu s$
		Full	-	-	95	$\mu V/\mu s$
Hold Step Error	$V_{IL} = 0V, V_{IH} = 4.0V, t_R = 5ns$	25	-	15	-	mV
Hold Mode Settling Time	To $\pm 1mV$	Full	-	200	300	ns
Hold Mode Feedthrough	20V _{P-P} , 200kHz, Sine	Full	-	-76	-	dB
EADT (Effective Aperture Delay Time)		25	-	-15	-	ns
Aperture Uncertainty		25	-	0.2	-	ns

HA-5340

Electrical Specifications $V_{SUPPLY} = \pm 15.0V$; $C_H = \text{Internal} = 135pF$; Digital Input: $V_{IL} = +0.8V$ (Sample), $V_{IH} = +2.0V$ (Hold). Non-Inverting Unity Gain Configuration (Output tied to -Input), $R_L = 2k\Omega$, $C_L = 60pF$, Unless Otherwise Specified **(Continued)**

PARAMETER	TEST CONDITIONS	TEMP. (°C)	HA-5340-5			UNITS
			MIN	TYP	MAX	
POWER SUPPLY CHARACTERISTICS						
Positive Supply Current		Full	-	19	25	mA
Negative Supply Current		Full	-	19	25	mA
PSRR	10% Delta	Full	75	82	-	dB

NOTES:

- Derived from Computer Simulation only, not tested.
- +CMRR is measured from 0V to +10V, -CMRR is measured from 0V to -10V.
- Based on the calculation $FPBW = \text{Slew Rate} / 2\pi V_{PEAK}$ ($V_{PEAK} = 10V$).

Test Circuits and Waveforms

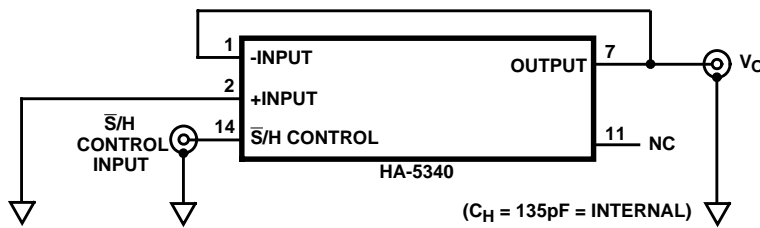
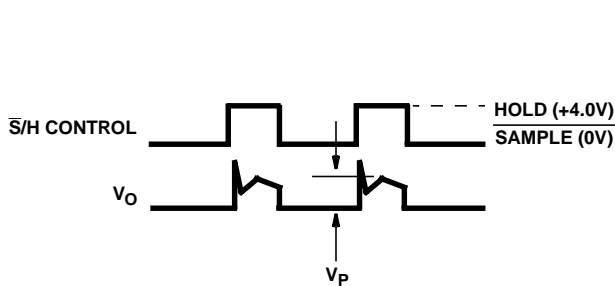

FIGURE 1. HOLD STEP ERROR AND DROOP RATE



NOTE:

- Observe the "hold step" voltage V_p .

FIGURE 2. HOLD STEP ERROR

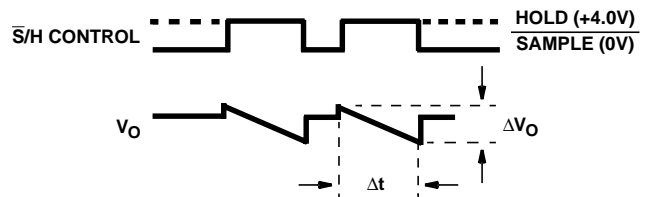

NOTES:

- Observe the voltage "droop", $\Delta V_O / \Delta t$.
- Measure the slope of the output during hold, $\Delta V_O / \Delta t$.
- Droop can be positive or negative - usually to one rail or the other not to GND.

FIGURE 3. DROOP RATE TEST

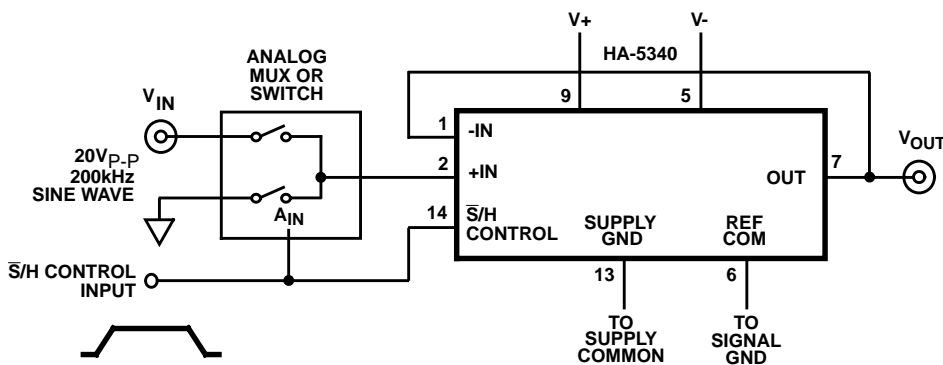

FIGURE 4. HOLD MODE FEEDTHROUGH ATTENUATION

NOTE:

- Feedthrough in

$$dB = 20 \log \frac{V_{OUT}}{V_{IN}} \quad \text{where:}$$

$$V_{OUT} = V_{P-P, \text{ Hold Mode,}}$$

$$V_{IN} = V_{P-P}$$

Typical Performance Curves $T_A = 25^\circ\text{C}$, $V_S = \pm 15\text{V}$, Unless Otherwise Specified

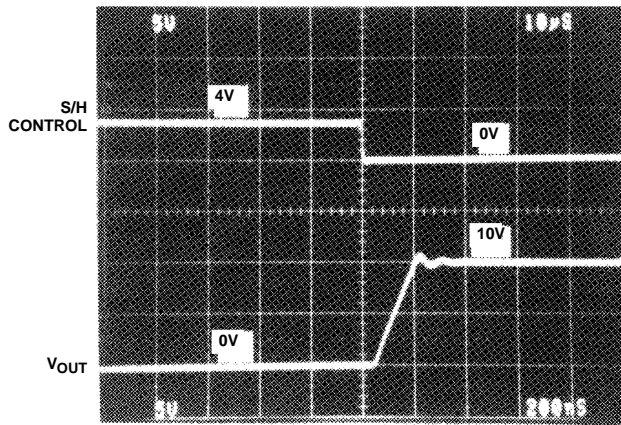

FIGURE 6. T_{ACQ} POS 0 TO +10 STEP

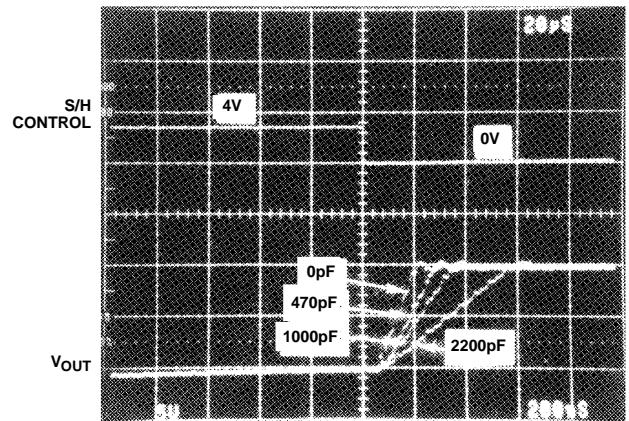

FIGURE 7. T_{ACQ} vs ADDITIONAL C_H

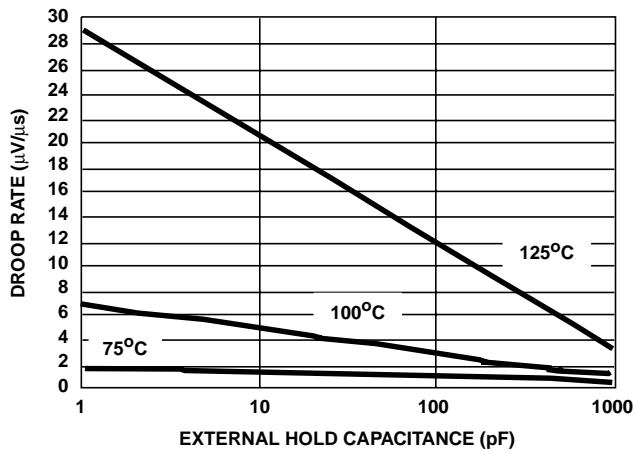

FIGURE 8. DROOP RATE vs HOLD CAPACITANCE

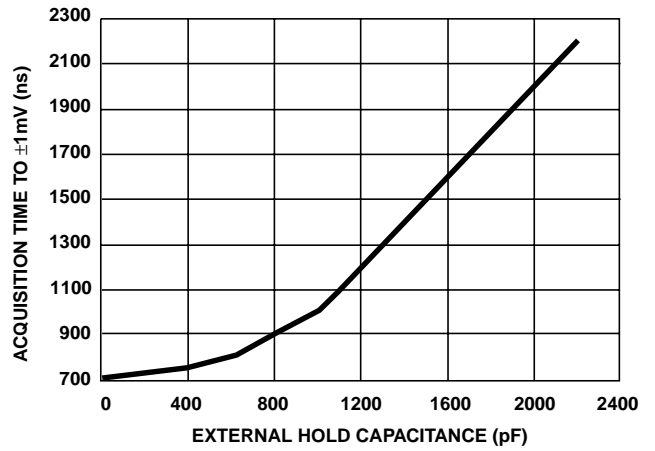

FIGURE 9. ACQUISITION TIME (0.01%) vs HOLD CAPACITANCE

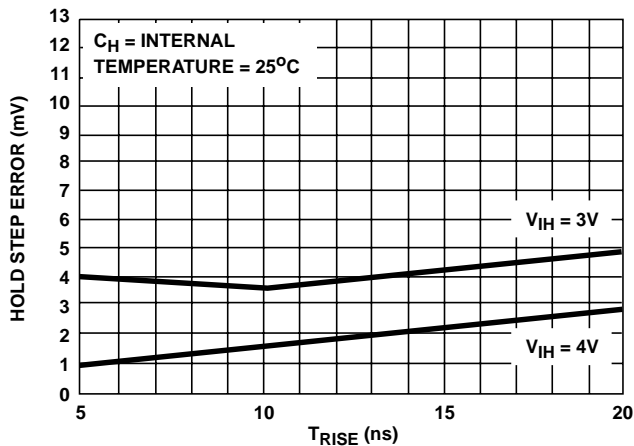

FIGURE 10. HOLD STEP ERROR vs T_{RISE}

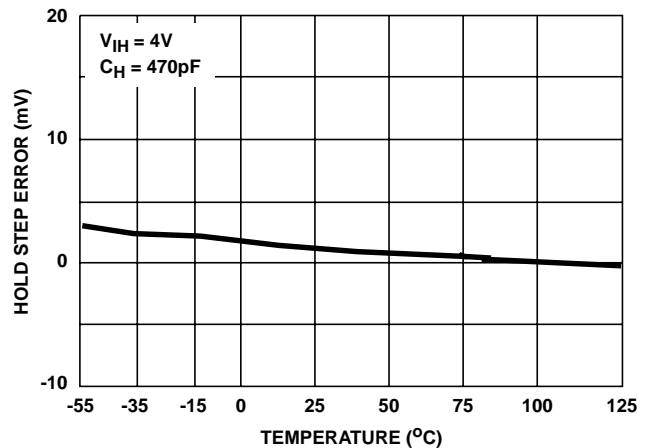

FIGURE 11. HOLD STEP ERROR vs TEMPERATURE

Typical Performance Curves $T_A = 25^\circ\text{C}$, $V_S = \pm 15\text{V}$, Unless Otherwise Specified (Continued)

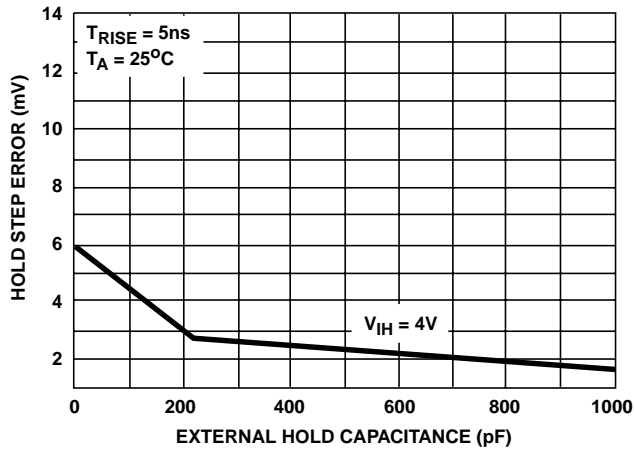

FIGURE 12. HOLD STEP ERROR vs HOLD CAPACITANCE

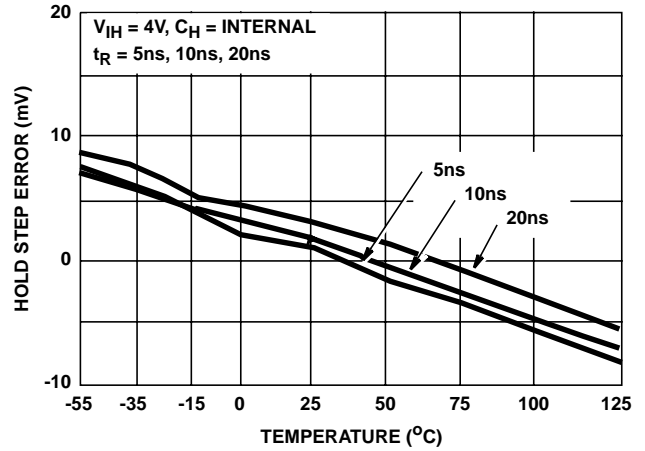
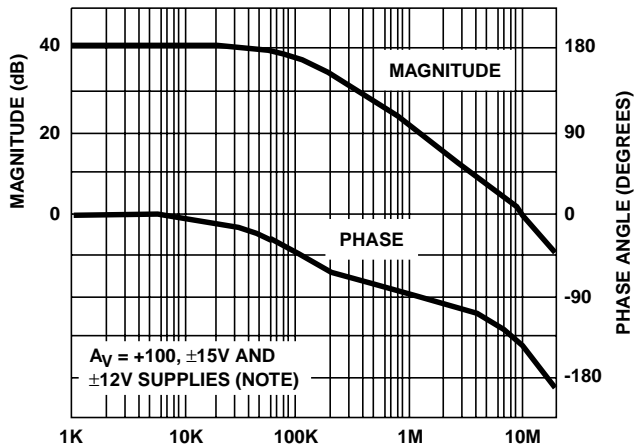

FIGURE 13. HOLD STEP ERROR vs TEMPERATURE



NOTE: $\pm 15\text{V}$ and $\pm 12\text{V}$ supplies trace the same line within the width of the line, therefore only one line is shown.

FIGURE 14. CLOSED LOOP PHASE/GAIN

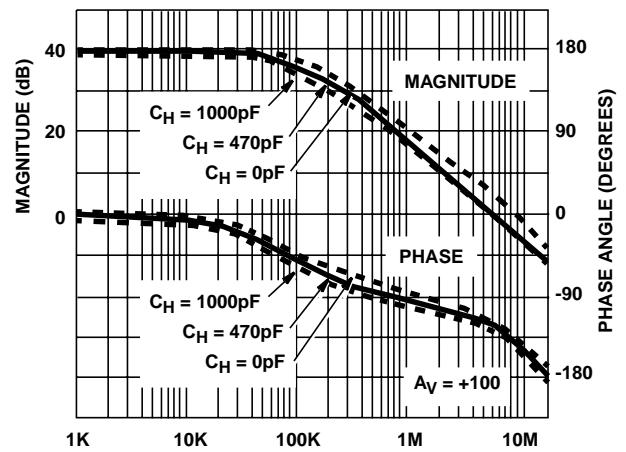

FIGURE 15. CLOSED LOOP PHASE/GAIN

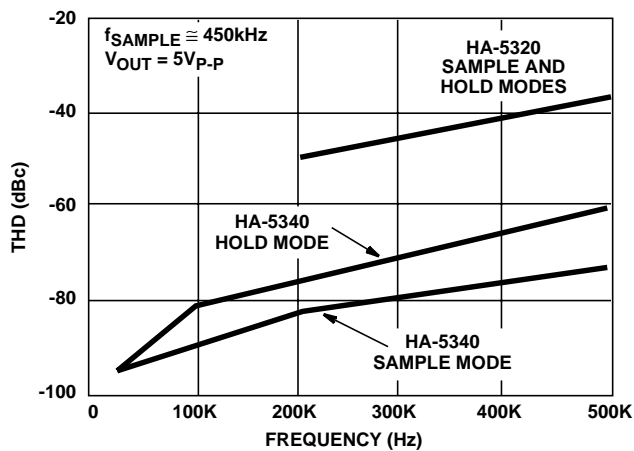

FIGURE 16. THD vs FREQUENCY

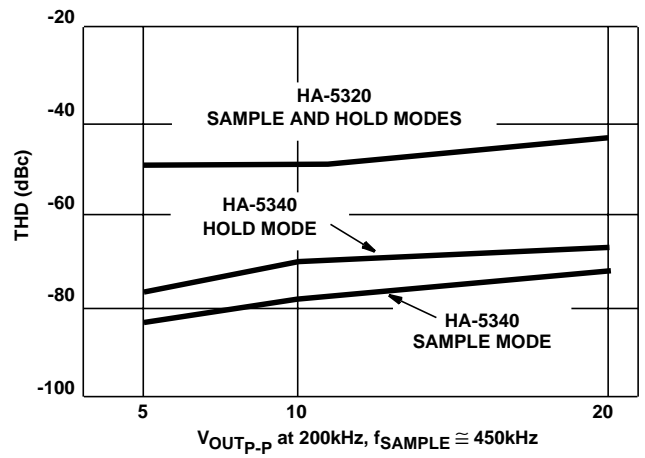

FIGURE 17. THD vs V_{OUT}

Die Characteristics

DIE DIMENSIONS:

84mils x 139mils x 19mils

METALLIZATION:

Type: Al, 1% Cu
 Thickness: $16\text{k}\text{\AA} \pm 2\text{k}\text{\AA}$

PASSIVATION:

Type: Nitride (Si_3N_4) over Silox (SiO_2 , 5% Phos)
 Silox Thickness: $12\text{k}\text{\AA} \pm 2.0\text{k}\text{\AA}$
 Nitride Thickness: $3.5\text{k}\text{\AA} \pm 1.5\text{k}\text{\AA}$

SUBSTRATE POTENTIAL (Powered Up):

V-

TRANSISTOR COUNT:

196

Metallization Mask Layout

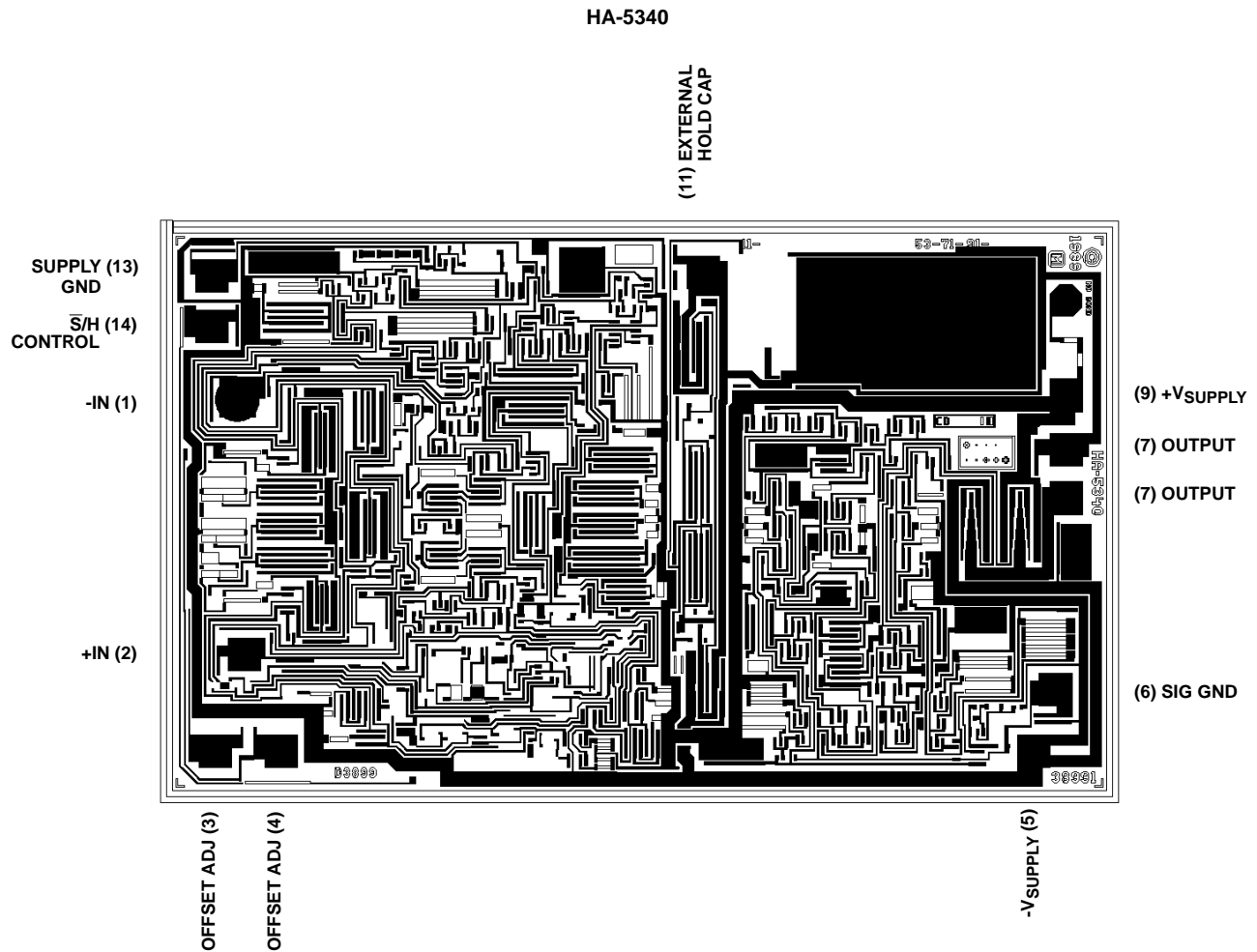

All Intersil semiconductor products are manufactured, assembled and tested under **ISO9000** quality systems certification.

Intersil semiconductor products are sold by description only. Intersil Corporation reserves the right to make changes in circuit design and/or specifications at any time without notice. Accordingly, the reader is cautioned to verify that data sheets are current before placing orders. Information furnished by Intersil is believed to be accurate and reliable. However, no responsibility is assumed by Intersil or its subsidiaries for its use; nor for any infringements of patents or other rights of third parties which may result from its use. No license is granted by implication or otherwise under any patent or patent rights of Intersil or its subsidiaries.

For information regarding Intersil Corporation and its products, see web site <http://www.intersil.com>

This datasheet has been downloaded from:

www.DatasheetCatalog.com

Datasheets for electronic components.



LittleDiode supplies new, hard to find or obsolete electronic components and semiconductors all over the world.

With over two million different components listed you are sure to find the part you need.

Feel free to visit us today at our online store:

LittleDiode.com

Looking forward to providing you with the best possible service.