

# Low Current Bar Code Digitizer IC

## Technical Data

### HBCC-0500

#### Features

- **Compatible with HP Bar Code Sensors**
  - HBCC-1570 - 0.013 in. 0.33 mm
  - HBCC-1580 - 0.007 in. 0.185 mm
  - HBCC-1590 - 0.005 in. 0.13 mm
- **Ambient Light Rejection > 100 K Lux**
- **Accurate Digitizing of a Wide Range of Bar Code Labels**

#### Description

The Hewlett-Packard Low Current Bar Code Digitizer IC allows designers to incorporate the high ambient light rejection and low power consumption features of the HBCS-AXXX/TXXX wands into their own bar code circuitry. The HBCC-0500 is packaged in a 24 pin SOIC plastic package.

#### Theory of Operation

The digitizer IC uses the techniques in US Patent 4,682,015 to reduce power consumption and sensitivity to ambient light. Power is reduced by pulsing the LED every 33 microseconds with a 1 microsecond pulse. The

output of different sensor "bins" is equalized by varying the amplitude of the LED drive current.

The sensor output has two components; DC due to ambient light, and AC from the bar code label. Photocurrent from the sensor is amplified and high pass filtered to remove the ambient light signal. The AC component is amplified and sent to an AM detector to recover the bar code information. The recovered bar code signal is low pass filtered to eliminate the 30 kHz carrier. The signal is input to a digitizer consisting of positive and negative

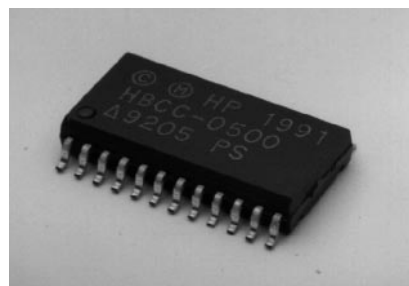

peak detectors and a comparator. The comparator threshold is generated from the peak detectors using a resistor ladder. This threshold, along with the current bar code signal, is input to a comparator. The output of the comparator drives an external output transistor.

#### Block Diagram

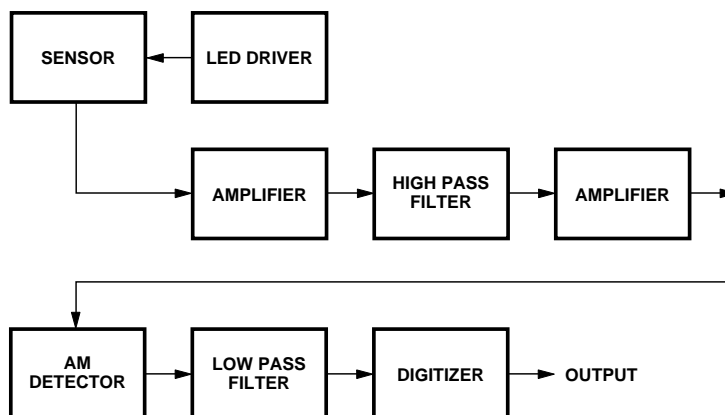

## Pinout

RPER	1	24	LEDD
RPWD	2	23	GND
CTIM	3	22	LPFO
V <sub>CC</sub>	4	21	LPFI
AGND	5	20	IWSR
EMIN	6	19	CMPO
PREO	7	18	CTHR
V <sub>CCA</sub>	8	17	CMPI
PPKD	9	16	NPKD
PRBP	10	15	PSTI
PSTB	11	14	CMPA
ACMP	12	13	AMDT

## Sensor Pinout

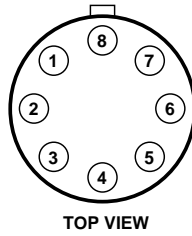

Function	Pin #
LED Anode	6
LED Cathode	2
Detector Anode	8
Detector Cathode	1

## Pin Description

Mnemonic	Description
RPER	Timer Period
RPWD	Timer Pulse Width
CTIM	Timer Capacitor
V <sub>CC</sub>	Filtered Power
AGND	Analog Ground
EMIN	Preamp Emitter Input
PREO	Preamp Output
V <sub>CCA</sub>	Analog Power
PPKD	Positive Peak Detector
PRBP	Preamp Bias Point
PSTB	Postamp Bypass
ACMP	Compensation Cap
AMDT	AM Detector
CMPA	Compensation Cap
PSTI	Postamp Input
NPKD	Negative Peak Detector
CMPI	Comparator Input
CTHR	Comparator Threshold
CMPO	Comparator Output
IWSR	White State Return Current
LPFI	Low Pass Filter Input
LPFO	Low Pass Filter Output
GND	Ground
LEDD	LED Drive

## Bin Table

Bin #	1570, 1580 Rb Ω	1590 Rb Ω
1	8.2	22
2	11	27
3	15	36
4	18	47
5	24	56
6	30	75
7	36	91

## Sensor Marking

Sensors are marked with an eight digit code, the last digit being the “bin” number. The bin number is used to determine the bin resistor, R<sub>b</sub>, using the Bin Table.

## Parts List

Quantity	Part
1	Sensor
1	HBCC-0500
1	1N4148
1	2N3904
1	2N4403
1	2N5088
2	39 Ω
1	9.1 kΩ
2	20 kΩ
2	56 kΩ
1	390 kΩ
2	470 kΩ
1	680 kΩ
1	1.3 MΩ
1	2.0 MΩ
2	6.8 MΩ
1	Bin resistor R <sub>b</sub>
1	12 pF
1	75 pF
1	330 pF
1	680 pF
2	1.0 nF
1	2.2 nF
1	8.2 nF
4	0.1 μF
3	0.22 μF
1	0.47 μF

## Optional Parts List

Quantity	Part
1	1N4148
1	2N5088
1	2N3904
2	10 kΩ
1	220 kΩ
1	1.0 MΩ
1	2.0 MΩ
1	3.3 nF
1	1.0 μF

## Recommended Schematic

Shown is the recommended schematic for the HBCC-0500.

Here are some construction tips.

1. Place the sensor, 2N4403, bin resistor, and the 0.47  $\mu\text{F}$  cap close to each other to minimize loop area.
2. If the 0.47  $\mu\text{F}$  cap is tantalum, its ESR must be used in series with  $R_b$  to determine the correct value for  $R_b$ .

3. A 1.0  $\mu\text{F}$  ceramic cap may be used in place of the 0.47  $\mu\text{F}$  cap.
4. Place the 0.22  $\mu\text{F}$  cap attached to pins 4 and 23 close to the IC.
5. Use a single point ground close to pin 23.

## Options

There are four options on the recommended schematic.

1. Output pull up resistor
2. Inverted output
3. Black state return
4. Threshold adjust

## Pull Up Resistor

The 10 k $\Omega$  pull up resistor on the standard or inverted output transistor is optional. If the transistor is driving a cable, the resistor should be on the far end of the cable.

## Schematic

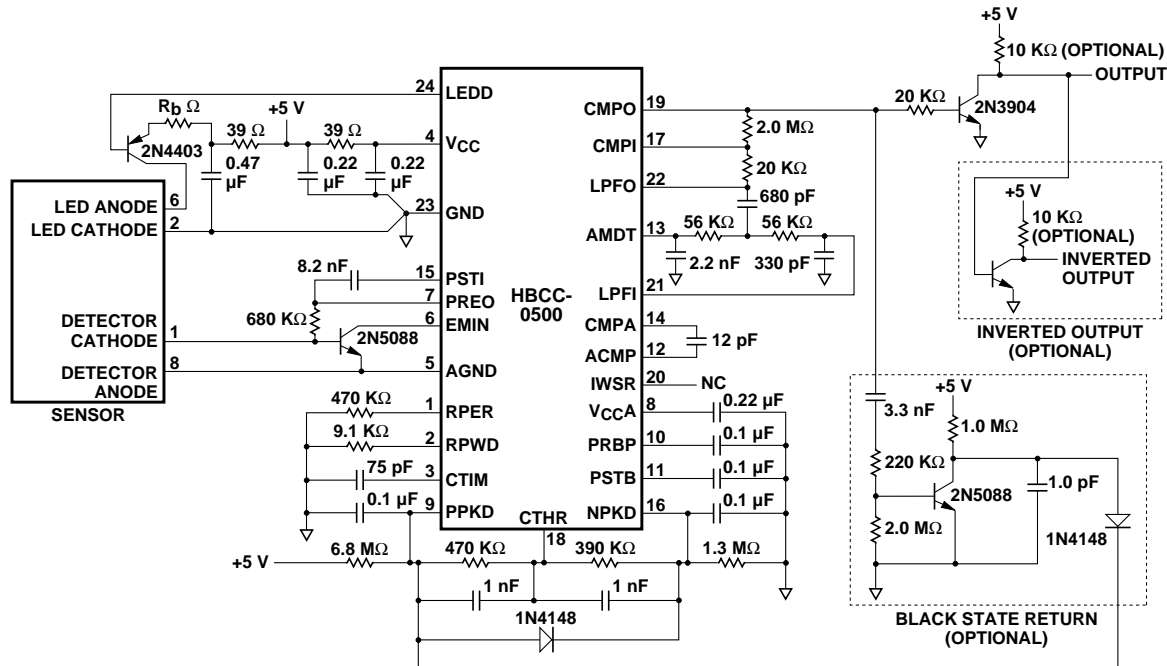

### Inverted Output

The standard output of the HBCC-0500 is high when the sensor is looking at black bars, and low when the sensor is looking at white spaces. If inverted output is needed, add the extra circuitry in the inverted output block. Make sure that the 10 kΩ pull up resistor on the normal output transistor is loaded.

### Black State Return

The HBCC-0500 normally returns to the white state 100 milliseconds after the last transition. The extra circuitry forces the black state after a time out period set by the 1.0 μF cap. The normal time out period is about 1.5 seconds. If a longer time is needed,

increase the values of the 1.0 μF and the 3.3 nF caps. The ratio of values should be no more than 300:1.

### Threshold Adjustment

The standard circuit uses a threshold designed for most bar codes. If the bar codes to be read *consistently* have narrow bars that are lighter than the wide bars, then the 470 kΩ and the 390 kΩ resistors attached to pin 18 should be swapped.

### Warranty and Service

HP Digitizer ICs are warranted for a period of one year after purchase covering defects in material and workmanship. Hewlett-Packard will repair or, at

its option, replace products that prove to be defective in material or workmanship under proper use during the warranty period.

NO OTHER WARRANTIES ARE EXPRESSED OR IMPLIED, INCLUDING BUT NOT LIMITED TO THE IMPLIED WARRANTIES OF MERCHANTABILITY AND FITNESS FOR A PARTICULAR PURPOSE. HEWLETT-PACKARD IS NOT LIABLE FOR CONSEQUENTIAL DAMAGES.

For additional warranty or service information, please contact your local Hewlett-Packard sales representative or authorized distributor.

## Recommended Operating Conditions

Parameter	Min.	Max.	Units	Notes
Scan Velocity	7.6 (3)	76 (30)	cm/sec (in/sec)	1
Edge Contrast	40		%	2
V <sub>CC</sub>	4.5	6.0	V	3
Ambient Temperature	-20	+65	°C	
Ambient Light		100,000	Lux	

#### Notes:

1. Narrow element width = 0.19 mm (0.0075 in.).
2. Contrast is defined as  $R_w - R_b$ , where  $R_w$  is the reflectance of the spaces in  $R_b$  is the reflectance of the bars, measured at the sensor wavelength (655 or 820 nm). 100% reflectance is barium sulfate.
3. Power supply ripple and noise should be less than 100 mV peak to peak.

## Electrical Characteristics

Parameter	Symbol	Typical	Max.	Units	Notes
Supply Current, IC and Sensor	I <sub>CC</sub>	2.7	4.0	mA	
High Level Output Current	I <sub>OH</sub>		1.0	μA	
Low Level Output Voltage	V <sub>OL</sub>		0.4	V	
Output Rise Time	t <sub>r</sub>	4.5	20	μs	4
Output Fall Time	t <sub>f</sub>	0.3	20	μs	4
Wake Up Time	t <sub>w</sub>	50	200	ms	5

#### Notes:

4. Rise and fall time will be dependent upon the capacitance of the cable.
5. Wake up time is defined as the time from initial power turn on until the circuit is digitizing bar codes within data sheet limits.



LittleDiode supplies new, hard to find or obsolete electronic components and semiconductors all over the world.

With over two million different components listed you are sure to find the part you need.

Feel free to visit us today at our online store:

[LittleDiode.com](http://LittleDiode.com)

Looking forward to providing you with the best possible service.