

HC05

MC68HC05X16

MC68HC05X32

MC68HC705X32

TECHNICAL
DATA

INTRODUCTION	1
MODES OF OPERATION AND PIN DESCRIPTIONS	2
MEMORY AND REGISTERS	3
INPUT/OUTPUT PORTS	4
MOTOROLA CAN MODULE (MCAN)	5
PROGRAMMABLE TIMER	6
SERIAL COMMUNICATIONS INTERFACE	7
PULSE LENGTH D/A CONVERTERS	8
ANALOG TO DIGITAL CONVERTER	9
RESETS AND INTERRUPTS	10
CPU CORE AND INSTRUCTION SET	11
ELECTRICAL SPECIFICATIONS	12
MECHANICAL DATA	13
ORDERING INFORMATION	14
APPENDICES	15

1	INTRODUCTION
2	MODES OF OPERATION AND PIN DESCRIPTIONS
3	MEMORY AND REGISTERS
4	INPUT/OUTPUT PORTS
5	MOTOROLA CAN MODULE (MCAN)
6	PROGRAMMABLE TIMER
7	SERIAL COMMUNICATIONS INTERFACE
8	PULSE LENGTH D/A CONVERTERS
9	ANALOG TO DIGITAL CONVERTER
10	RESETS AND INTERRUPTS
11	CPU CORE AND INSTRUCTION SET
12	ELECTRICAL SPECIFICATIONS
13	MECHANICAL DATA
14	ORDERING INFORMATION
15	APPENDICES

MC68HC05X16 MC68HC05X32 MC68HC705X32

High-density complementary metal oxide semiconductor (HCMOS) microcontroller unit

All Trade Marks recognized. This document contains information on new products. Specifications and information herein are subject to change without notice.

All products are sold on Motorola's Terms & Conditions of Supply. In ordering a product covered by this document the Customer agrees to be bound by those Terms & Conditions and nothing contained in this document constitutes or forms part of a contract (with the exception of the contents of this Notice). A copy of Motorola's Terms & Conditions of Supply is available on request.

Motorola reserves the right to make changes without further notice to any products herein. Motorola makes no warranty, representation or guarantee regarding the suitability of its products for any particular purpose, nor does Motorola assume any liability arising out of the application or use of any product or circuit, and specifically disclaims any and all liability, including without limitation consequential or incidental damages. "Typical" parameters can and do vary in different applications. All operating parameters, including "Typicals", must be validated for each customer application by customer's technical experts. Motorola does not convey any license under its patent rights nor the rights of others. Motorola products are not designed, intended, or authorized for use as components in systems intended for surgical implant into the body, or other applications intended to support or sustain life, or for any other application in which the failure of the Motorola product could create a situation where personal injury or death may occur. Should Buyer purchase or use Motorola products for any such unintended or unauthorized application, Buyer shall indemnify and hold Motorola and its officers, employees, subsidiaries, affiliates, and distributors harmless against all claims, costs, damages, and expenses, and reasonable attorney fees arising out of, directly or indirectly, any claim of personal injury or death associated with such unintended or unauthorized use, even if such claim alleges that Motorola was negligent regarding the design or manufacture of the part. Motorola and  are registered trademarks of Motorola, Inc. Motorola, Inc. is an Equal Opportunity/Affirmative Action Employer.

The Customer should ensure that it has the most up to date version of the document by contacting its local Motorola office. This document supersedes any earlier documentation relating to the products referred to herein. The information contained in this document is current at the date of publication. It may subsequently be updated, revised or withdrawn.

Conventions

Where abbreviations are used in the text, an explanation can be found in the glossary, at the back of this manual. Register and bit mnemonics are defined in the paragraphs describing them.

An overbar is used to designate an active-low signal, eg: $\overline{\text{RESET}}$.

Unless otherwise stated, a shaded cell in a register diagram indicates that the bit is either unused or reserved; 'u' is used to indicate an undefined state (on reset).

Unless otherwise stated, a pin labelled as 'NU' should be tied to V_{SS} in an electrically noisy environment. Pins labelled 'NC' can be left floating, since they are not bonded to any part of the device.

CUSTOMER FEEDBACK QUESTIONNAIRE (MC68HC05X16/D)

Motorola wishes to continue to improve the quality of its documentation. We would welcome your feedback on the publication you have just received. Having used the document, please complete this card (or a photocopy of it, if you prefer).

1. How would you rate the quality of the document? Check one box in each category.

	Excellent			Poor		Excellent			Poor
Organization	<input type="checkbox"/>	<input type="checkbox"/>	<input type="checkbox"/>	<input type="checkbox"/>	Tables	<input type="checkbox"/>	<input type="checkbox"/>	<input type="checkbox"/>	<input type="checkbox"/>
Readability	<input type="checkbox"/>	<input type="checkbox"/>	<input type="checkbox"/>	<input type="checkbox"/>	Table of contents	<input type="checkbox"/>	<input type="checkbox"/>	<input type="checkbox"/>	<input type="checkbox"/>
Understandability	<input type="checkbox"/>	<input type="checkbox"/>	<input type="checkbox"/>	<input type="checkbox"/>	Index	<input type="checkbox"/>	<input type="checkbox"/>	<input type="checkbox"/>	<input type="checkbox"/>
Accuracy	<input type="checkbox"/>	<input type="checkbox"/>	<input type="checkbox"/>	<input type="checkbox"/>	Page size/binding	<input type="checkbox"/>	<input type="checkbox"/>	<input type="checkbox"/>	<input type="checkbox"/>
Illustrations	<input type="checkbox"/>	<input type="checkbox"/>	<input type="checkbox"/>	<input type="checkbox"/>	Overall impression	<input type="checkbox"/>	<input type="checkbox"/>	<input type="checkbox"/>	<input type="checkbox"/>

Comments: _____

2. What is your intended use for this document? If more than one option applies, please rank them (1, 2, 3).

Selection of device for new application	<input type="checkbox"/>	Other <input type="checkbox"/> Please specify: _____
System design	<input type="checkbox"/>	_____
Training purposes	<input type="checkbox"/>	_____

3. How well does this manual enable you to perform the task(s) outlined in question 2?

Completely		Not at all	Comments: _____
<input type="checkbox"/>	<input type="checkbox"/>	<input type="checkbox"/>	_____

4. How easy is it to find the information you are looking for?

Easy		Difficult	Comments: _____
<input type="checkbox"/>	<input type="checkbox"/>	<input type="checkbox"/>	_____

5. Is the level of technical detail in the following sections sufficient to allow you to understand how the device functions?

	Too little detail			Too much detail	
SECTION 1 INTRODUCTION	<input type="checkbox"/>	<input type="checkbox"/>	<input type="checkbox"/>	<input type="checkbox"/>	<input type="checkbox"/>
SECTION 2 MODES OF OPERATION AND PIN DESCRIPTIONS	<input type="checkbox"/>	<input type="checkbox"/>	<input type="checkbox"/>	<input type="checkbox"/>	<input type="checkbox"/>
SECTION 3 MEMORY AND REGISTERS	<input type="checkbox"/>	<input type="checkbox"/>	<input type="checkbox"/>	<input type="checkbox"/>	<input type="checkbox"/>
SECTION 4 INPUT/OUTPUT PORTS	<input type="checkbox"/>	<input type="checkbox"/>	<input type="checkbox"/>	<input type="checkbox"/>	<input type="checkbox"/>
SECTION 5 MOTOROLA CAN MODULE (MCAN)	<input type="checkbox"/>	<input type="checkbox"/>	<input type="checkbox"/>	<input type="checkbox"/>	<input type="checkbox"/>
SECTION 6 PROGRAMMABLE TIMER	<input type="checkbox"/>	<input type="checkbox"/>	<input type="checkbox"/>	<input type="checkbox"/>	<input type="checkbox"/>
SECTION 7 SERIAL COMMUNICATIONS INTERFACE	<input type="checkbox"/>	<input type="checkbox"/>	<input type="checkbox"/>	<input type="checkbox"/>	<input type="checkbox"/>
SECTION 8 PULSE LENGTH D/A CONVERTERS	<input type="checkbox"/>	<input type="checkbox"/>	<input type="checkbox"/>	<input type="checkbox"/>	<input type="checkbox"/>
SECTION 9 ANALOG TO DIGITAL CONVERTER	<input type="checkbox"/>	<input type="checkbox"/>	<input type="checkbox"/>	<input type="checkbox"/>	<input type="checkbox"/>
SECTION 10 RESETS AND INTERRUPTS	<input type="checkbox"/>	<input type="checkbox"/>	<input type="checkbox"/>	<input type="checkbox"/>	<input type="checkbox"/>
SECTION 11 CPU CORE AND INSTRUCTION SET	<input type="checkbox"/>	<input type="checkbox"/>	<input type="checkbox"/>	<input type="checkbox"/>	<input type="checkbox"/>
SECTION 12 ELECTRICAL SPECIFICATIONS	<input type="checkbox"/>	<input type="checkbox"/>	<input type="checkbox"/>	<input type="checkbox"/>	<input type="checkbox"/>
SECTION 13 MECHANICAL DATA	<input type="checkbox"/>	<input type="checkbox"/>	<input type="checkbox"/>	<input type="checkbox"/>	<input type="checkbox"/>
SECTION 14 ORDERING INFORMATION	<input type="checkbox"/>	<input type="checkbox"/>	<input type="checkbox"/>	<input type="checkbox"/>	<input type="checkbox"/>
SECTION 15 APPENDICES	<input type="checkbox"/>	<input type="checkbox"/>	<input type="checkbox"/>	<input type="checkbox"/>	<input type="checkbox"/>

Comments: _____

6. Have you found any errors? If so, please comment: _____

7. From your point of view, is anything missing from the document? If so, please say what: _____

- Cut along this line to remove -





8. How could we improve this document? _____

9. How would you rate Motorola's documentation?
- | | | | |
|---|--------------------------|--------------------------|--------------------------|
| | Excellent | | Poor |
| - In general | <input type="checkbox"/> | <input type="checkbox"/> | <input type="checkbox"/> |
| - Against other semiconductor suppliers | <input type="checkbox"/> | <input type="checkbox"/> | <input type="checkbox"/> |
10. Which semiconductor manufacturer provides the best technical documentation? _____
11. Which company (in any field) provides the best technical documentation? _____
12. How many years have you worked with microprocessors?
- Less than 1 year 1-3 years 3-5 years More than 5 years

- Second fold back along this line -

**By air mail
Par avion**

IBRS NUMBER PHQ-B/207/G
CCRI NUMERO PHQ-B/207/G

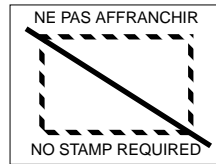

- First fold back along this line -

- Cut along this line to remove -

**REPONSE PAYEE
GRANDE-BRETAGNE**

Motorola Ltd.,
Colvilles Road,
Kelvin Industrial Estate,
EAST KILBRIDE,
G75 8BR.
GREAT BRITAIN.



F.A.O. Technical Publications Manager
(re: MC68HC05X16/D)

- Third fold back along this line -

13. Currently there is some discussion in the semiconductor industry regarding a move towards providing data sheets in electronic form. If you have any opinion on this subject, please comment. _____

14. We would be grateful if you would supply the following information (at your discretion), or attach your card.
- Name: _____ Phone No: _____
 Position: _____ FAX No: _____
 Department: _____
 Company: _____
 Address: _____

*Thank you for helping us improve our documentation,
Graham Forbes, Technical Publications Manager, Motorola Ltd., Scotland.*

- Finally, tuck this edge into opposite flap -

TABLE OF CONTENTS

Paragraph Number	TITLE	Page Number
1		
INTRODUCTION		
1.1	Features	1-2
1.2	Mask options for the MC68HC05X16	1-3
2		
MODES OF OPERATION AND PIN DESCRIPTIONS		
2.1	Modes of operation	2-1
2.1.1	Single-chip mode	2-1
2.1.2	Bootstrap mode	2-2
2.1.2.1	Serial RAM loader	2-3
2.1.2.2	Jump to RAM + 1	2-3
2.1.2.3	'Jump to any address'	2-3
2.2	Low power modes	2-6
2.2.1	STOP mode	2-6
2.2.2	WAIT mode	2-7
2.2.2.1	Power consumption during WAIT mode	2-8
2.2.3	SLOW mode	2-8
2.2.3.1	Miscellaneous register	2-10
2.3	Pin descriptions	2-11
2.3.1	VDD and VSS	2-11
2.3.2	$\overline{\text{IRQ}}$	2-11
2.3.3	RESET	2-11
2.3.4	MDS	2-12
2.3.5	TCAP1	2-12
2.3.6	TCAP2	2-12
2.3.7	TCMP1	2-12
2.3.8	TCMP2	2-12
2.3.9	RDI (Receive data in)	2-12
2.3.10	TDO (Transmit data out)	2-12
2.3.11	SCLK	2-13

Paragraph Number	TITLE	Page Number
2.3.12	OSC1, OSC2	2-13
2.3.12.1	Crystal	2-13
2.3.12.2	Ceramic resonator	2-13
2.3.12.3	External clock	2-13
2.3.12.4	Oscillator division	2-15
2.3.13	PLMA	2-15
2.3.14	PLMB	2-15
2.3.15	VPP1	2-16
2.3.16	VRH	2-16
2.3.17	VRL	2-16
2.3.18	PA0 – PA7/PB0 – PB7/PC0 – PC7	2-16
2.3.19	NWOI	2-16
2.3.20	PD0/AN0–PD7/AN7	2-16
2.3.21	VDD1	2-17
2.3.22	VSS1	2-17
2.3.23	VDDH	2-17
2.3.24	RX0/RX1	2-17
2.3.25	TX0/TX1	2-17

3

MEMORY AND REGISTERS

3.1	Registers	3-1
3.2	RAM	3-1
3.3	ROM	3-1
3.4	Bootstrap ROM	3-3
3.5	EEPROM	3-4
3.5.1	EEPROM control register	3-4
3.5.2	EEPROM read operation	3-6
3.5.3	EEPROM erase operation	3-6
3.5.4	EEPROM programming operation	3-7
3.5.5	Options register (OPTR)	3-7
3.6	EEPROM during STOP mode	3-8
3.7	EEPROM during WAIT mode	3-8
3.8	Miscellaneous register	3-11

4

INPUT/OUTPUT PORTS

4.1	Input/output programming	4-1
4.2	Ports A and B	4-2
4.3	Port C	4-3
4.4	Port D	4-4
4.5	Port registers	4-4

Paragraph Number	TITLE	Page Number
4.5.1	Port data registers A and B (PORTA and PORTB)	4-4
4.5.2	Port data register C (PORTC)	4-5
4.5.3	Port data register D (PORTD)	4-5
4.5.4	A/D status/control register	4-5
4.5.5	Data direction registers (DDRA, DDRB and DDRC).....	4-6
4.6	Other port considerations	4-6

5

MOTOROLA CAN MODULE (MCAN)

5.1	TBF – Transmit buffer	5-4
5.2	RBF – Receive buffer	5-4
5.3	Interface to the MC68HC05X16 CPU	5-4
5.3.1	MCAN control register (CCNTRL)	5-6
5.3.2	MCAN command register (CCOM)	5-7
5.3.3	MCAN status register (CSTAT)	5-10
5.3.4	MCAN interrupt register (CINT)	5-12
5.3.5	MCAN acceptance code register (CACR).....	5-13
5.3.6	MCAN acceptance mask register (CACM)	5-14
5.3.7	MCAN bus timing register 0 (CBT0)	5-14
5.3.8	MCAN bus timing register 1 (CBT1)	5-16
5.3.9	MCAN output control register (COCNTRL).....	5-18
5.3.10	Transmit buffer identifier register (TBI).....	5-20
5.3.11	Remote transmission request and data length code register (TRTDL).....	5-20
5.3.12	Transmit data segment registers (TDS) 1 – 8	5-21
5.3.13	Receive buffer identifier register (RBI).....	5-21
5.3.14	Remote transmission request and data length code register (RRTDL)	5-22
5.3.15	Receive data segment registers (RDS) 1 – 8	5-22
5.4	Interface to the MCAN bus	5-22
5.4.1	Single wire operation	5-24
5.5	Sleep mode	5-24
5.5.1	Sleep comparator reference	5-25

6

PROGRAMMABLE TIMER

6.1	Counter.....	6-1
6.1.1	Counter register and alternate counter register	6-3
6.2	Timer control and status	6-4
6.2.1	Timer control register (TCR)	6-4
6.2.2	Timer status register (TSR)	6-6
6.3	Input capture.....	6-7
6.3.1	Input capture register 1 (ICR1)	6-7
6.3.2	Input capture register 2 (ICR2)	6-8

Paragraph Number	TITLE	Page Number
6.4	Output compare.....	6-9
6.4.1	Output compare register 1 (OCR1)	6-9
6.4.2	Output compare register 2 (OCR2)	6-10
6.4.3	Software force compare.....	6-11
6.5	Pulse length modulation (PLM)	6-11
6.5.1	Pulse length modulation registers A and B (PLMA/PLMB).....	6-11
6.6	Timer during STOP mode	6-12
6.7	Timer during WAIT mode	6-12
6.8	Timer state diagrams.....	6-12

7

SERIAL COMMUNICATIONS INTERFACE

7.1	SCI two-wire system features.....	7-1
7.2	SCI receiver features.....	7-3
7.3	SCI transmitter features.....	7-3
7.4	Functional description	7-3
7.5	Data format.....	7-5
7.6	Receiver wake-up operation.....	7-5
7.6.1	Idle line wake-up.....	7-6
7.6.2	Address mark wake-up	7-6
7.7	Receive data in (RDI).....	7-6
7.8	Start bit detection	7-6
7.9	Transmit data out (TDO).....	7-8
7.10	SCI synchronous transmission.....	7-9
7.11	SCI registers.....	7-10
7.11.1	Serial communications data register (SCDR).....	7-10
7.11.2	Serial communications control register 1 (SCCR1)	7-10
7.11.3	Serial communications control register 2 (SCCR2)	7-14
7.11.4	Serial communications status register (SCSR)	7-16
7.11.5	Baud rate register (BAUD)	7-18
7.12	Baud rate selection.....	7-20
7.13	SCI during STOP mode.....	7-21
7.14	SCI during WAIT mode.....	7-21

8

PULSE LENGTH D/A CONVERTERS

8.1	Miscellaneous register.....	8-3
8.2	PLM clock selection.....	8-4
8.3	PLM during STOP mode	8-4
8.4	PLM during WAIT mode	8-4

9
ANALOG TO DIGITAL CONVERTER

9.1	A/D converter operation.....	9-1
9.2	A/D registers.....	9-3
9.2.1	Port D data register (PORTD).....	9-3
9.2.2	A/D result data register (ADDATA).....	9-3
9.2.3	A/D status/control register (ADSTAT).....	9-4
9.3	A/D converter during STOP mode.....	9-5
9.4	A/D converter during WAIT mode.....	9-6
9.5	Port D analog input.....	9-6

10
RESETS AND INTERRUPTS

10.1	Resets	10-1
10.1.1	Power-on reset.....	10-2
10.1.2	Miscellaneous register	10-2
10.1.3	RESET pin	10-3
10.1.4	Computer operating properly (COP) watchdog reset	10-3
10.1.4.1	COP watchdog during STOP mode	10-5
10.1.4.2	COP watchdog during WAIT mode	10-5
10.1.5	Functions affected by reset.....	10-5
10.2	Interrupts	10-7
10.2.1	Interrupt priorities.....	10-9
10.2.2	Nonmaskable software interrupt (SWI).....	10-9
10.2.3	Maskable hardware interrupts.....	10-9
10.2.3.1	Miscellaneous register	10-10
10.2.3.2	External interrupts.....	10-11
10.2.3.3	MCAN interrupt (CIRQ).....	10-11
10.2.3.4	Timer interrupts.....	10-12
10.2.3.5	Serial communications interface (SCI) interrupts.....	10-12
10.2.4	Hardware controlled interrupt sequence.....	10-13

11
CPU CORE AND INSTRUCTION SET

11.1	Registers	11-1
11.1.1	Accumulator (A).....	11-1
11.1.2	Index register (X)	11-2
11.1.3	Program counter (PC).....	11-2
11.1.4	Stack pointer (SP).....	11-2
11.1.5	Condition code register (CCR).....	11-2
11.2	Instruction set	11-3

Paragraph Number	TITLE	Page Number
11.2.1	Register/memory Instructions.....	11-4
11.2.2	Branch instructions.....	11-4
11.2.3	Bit manipulation instructions.....	11-4
11.2.4	Read/modify/write instructions.....	11-4
11.2.5	Control instructions.....	11-4
11.2.6	Tables.....	11-4
11.3	Addressing modes.....	11-11
11.3.1	Inherent.....	11-11
11.3.2	Immediate.....	11-11
11.3.3	Direct.....	11-11
11.3.4	Extended.....	11-12
11.3.5	Indexed, no offset.....	11-12
11.3.6	Indexed, 8-bit offset.....	11-12
11.3.7	Indexed, 16-bit offset.....	11-12
11.3.8	Relative.....	11-13
11.3.9	Bit set/clear.....	11-13
11.3.10	Bit test and branch.....	11-13

12 ELECTRICAL SPECIFICATIONS

12.1	Absolute maximum ratings.....	12-1
12.2	DC electrical characteristics.....	12-2
12.3	A/D converter characteristics.....	12-4
12.4	Control timing.....	12-5
12.5	MCAN bus interface DC electrical characteristics.....	12-6
12.6	MCAN bus interface control timing characteristics.....	12-6

13 MECHANICAL DATA

13.1	64-pin quad flat pack (QFP) pinout.....	13-1
13.2	64-pin quad flat pack (QFP) mechanical dimensions.....	13-2

14 ORDERING INFORMATION

14.1	EPROMS.....	14-2
14.2	Verification media.....	14-2
14.3	ROM verification units (RVU).....	14-2

A
MC68HC05X32

A.1	Features	A-1
A.2	Memory map, register outline and block diagram	A-2
A.3	Electrical specifications	A-6
A.3.1	Maximum ratings.....	A-6
A.3.2	DC electrical characteristics	A-7
A.3.3	A/D converter characteristics.....	A-9
A.3.4	Control timing.....	A-10
A.3.5	MCAN bus interface DC electrical characteristics	A-11
A.3.6	MCAN bus interface control timing characteristics	A-12

B
MC68HC705X32

B.1	Features	B-2
B.2	VPP6	B-2
B.3	CANE.....	B-2
B.4	Block diagram, memory map and register outline	B-3
B.5	EPROM	B-7
B.5.1	EPROM read operation.....	B-7
B.5.2	EPROM program operation	B-8
B.5.3	EPROM/EEPROM/ECLK control register	B-8
B.6	EEPROM options register (OPTR)	B-11
B.7	Mask option register (MOR)	B-12
B.8	Bootstrap mode	B-14
B.8.1	Erased EPROM verification and EEPROM erasure	B-17
B.8.2	EPROM/EEPROM parallel bootstrap.....	B-17
B.8.3	Serial RAM loader.....	B-20
B.8.3.1	Jump to start of RAM (\$0051).....	B-20
B.9	Electrical specifications	B-23
B.9.1	Maximum ratings.....	B-23
B.9.2	DC electrical characteristics	B-24
B.9.3	EPROM electrical characteristics	B-26
B.9.4	Control timing.....	B-27
B.9.5	A/D converter characteristics.....	B-28
B.9.6	MCAN bus interface DC electrical characteristics	B-29
B.9.7	MCAN bus interface control timing characteristics	B-29

Paragraph
Number

TITLE

Page
Number

C
MC68HC05X32
HIGH SPEED OPERATION

C.1	DC electrical characteristics	C-1
C.2	Control Timing	C-2

LIST OF FIGURES

Figure Number	TITLE	Page Number
1-1	MC68HC05X16 block diagram	1-4
2-1	Bootstrap mode function selection flow chart.....	2-2
2-2	MC68HC05X16 'jump to any address' schematic diagram.....	2-4
2-3	MC68HC05X16 'load program in RAM and execute' schematic diagram.....	2-5
2-4	STOP and WAIT flow charts.....	2-9
2-5	Slow mode divider block diagram.....	2-10
2-6	Oscillator connections	2-14
2-7	Oscillator divider block diagram.....	2-15
3-1	Memory map of the MC68HC05X16	3-2
3-2	MCAN module memory map.....	3-3
4-1	Standard I/O port structure.....	4-2
4-2	ECLK timing diagram	4-3
4-3	Port logic levels	4-7
5-1	MCAN block diagram.....	5-1
5-2	MCAN frame formats.....	5-2
5-3	MCAN module memory map.....	5-5
5-4	Oscillator block diagram	5-15
5-5	Segments within the bit time	5-16
5-6	A typical physical interface between the MCAN and the MCAN bus lines	5-23
6-1	16-bit programmable timer block diagram	6-2
6-2	Timer state timing diagram for reset.....	6-13
6-3	Timer state timing diagram for input capture	6-13
6-4	Timer state timing diagram for output compare.....	6-14
6-5	Timer state timing diagram for timer overflow.....	6-14
7-1	Serial communications interface block diagram	7-2
7-2	SCI rate generator division.....	7-4
7-3	Data format.....	7-5
7-4	SCI examples of start bit sampling technique	7-7
7-5	SCI sampling technique used on all bits	7-7
7-6	Artificial start following a framing error	7-8
7-7	SCI start bit following a break.....	7-8
7-8	SCI example of synchronous and asynchronous transmission.....	7-9
7-9	SCI data clock timing diagram (M=0)	7-12

Figure Number	TITLE	Page Number
7-10	SCI data clock timing diagram (M=1)	7-13
8-1	PLM system block diagram	8-1
8-2	PLM output waveform examples	8-2
8-3	PLM clock selection	8-4
9-1	A/D converter block diagram	9-2
9-2	Electrical model of an A/D input pin	9-6
10-1	Reset timing diagram	10-1
10-2	RESET external RC pull-down	10-3
10-3	Watchdog system block diagram	10-4
10-4	Interrupt flow chart	10-8
11-1	Programming model	11-1
11-2	Stacking order	11-2
12-1	Timer relationship	12-5
13-1	64-pin QFP pinout	13-1
13-2	64-pin QFP mechanical dimensions	13-2
A-1	MC68HC05X32 block diagram	A-2
A-2	Memory map of the MC68HC05X32	A-3
A-3	Timer relationship	A-11
B-1	MC68HC705X32 block diagram	B-3
B-2	Memory map of the MC68HC705X32	B-5
B-3	Modes of operation flow chart	B-15
B-4	Timing diagram with handshake	B-18
B-5	Parallel EPROM loader timing diagram	B-18
B-6	EPROM parallel bootstrap schematic diagram	B-19
B-7	RAM load and execute schematic diagram	B-21
B-8	Parallel RAM loader timing diagram	B-22
B-9	Timer relationship	B-27

LIST OF TABLES

Table Number	TITLE	Page Number
1-1	Data sheet appendices.....	1-1
2-1	Mode of operation selection	2-1
3-1	EEPROM control bits description	3-6
3-2	MC68HC05X16 register outline.....	3-9
3-3	MCAN register outline	3-10
3-4	$\overline{\text{IRQ}}$ and WOI sensitivity	3-11
4-1	I/O pin states	4-2
5-1	Synchronization jump width.....	5-15
5-2	Baud rate prescaler	5-15
5-3	Time segment values	5-17
5-4	Output control modes	5-18
5-5	MCAN driver output levels.....	5-19
5-6	Data length codes	5-21
7-1	Method of receiver wake-up	7-11
7-2	SCI clock on SCLK pin	7-13
7-3	First prescaler stage.....	7-18
7-4	Second prescaler stage (transmitter)	7-18
7-5	Second prescaler stage (receiver)	7-19
7-6	SCI baud rate selection with CPU clock frequency = $f_{\text{OSC}}/2$	7-20
7-7	SCI baud rate selection with CPU clock frequency = $f_{\text{OSC}}/8$	7-20
7-8	SCI baud rate selection with CPU clock frequency = $f_{\text{OSC}}/10$	7-20
7-9	SCI transmit baud rate output for a given prescaler output	7-21
9-1	A/D clock selection	9-4
9-2	A/D channel assignment	9-5
10-1	Effect of $\overline{\text{RESET}}$, POR, STOP and WAIT.....	10-6
10-2	Interrupt priorities	10-9
10-3	$\overline{\text{IRQ}}$ and WOI sensitivity	10-10
11-1	MUL instruction	11-5
11-2	Register/memory instructions.....	11-5
11-3	Branch instructions.....	11-6
11-4	Bit manipulation instructions.....	11-6
11-5	Read/modify/write instructions	11-7
11-6	Control instructions.....	11-7

Table Number	TITLE	Page Number
11-7	Instruction set.....	11-8
11-8	M68HC05 opcode map	11-10
12-1	Absolute maximum ratings.....	12-1
12-2	DC electrical characteristics.....	12-2
12-3	A/D characteristics	12-4
12-4	Control timing	12-5
12-5	MCAN bus interface DC electrical characteristics.....	12-6
12-6	MCAN bus interface control timing characteristics.....	12-6
14-1	MC order numbers	14-1
14-2	EPROMs for pattern generation.....	14-2
A-1	Register outline	A-5
A-2	Maximum ratings.....	A-6
A-3	DC electrical characteristics.....	A-7
A-4	A/D characteristics	A-9
A-5	Control timing	A-10
1-6	MCAN bus interface DC electrical characteristics.....	A-11
1-7	MCAN bus interface control timing characteristics.....	A-12
B-1	Register outline	B-4
B-2	EPROM control bits description	B-9
B-3	EEPROM1 control bits description.....	B-10
B-4	Clock divide ratio selection.....	B-12
B-5	Mode of operation selection	B-14
B-6	Bootstrap vector targets in RAM	B-20
B-7	Maximum ratings.....	B-23
B-8	DC electrical characteristics.....	B-24
B-9	EPROM electrical characteristics.....	B-26
B-10	Control timing	B-27
B-11	A/D characteristics	B-28
B-12	MCAN bus interface DC electrical characteristics.....	B-29
B-13	MCAN bus interface control timing characteristics.....	B-29
C-1	DC electrical characteristics.....	C-1
C-2	Control timing	C-2

1

INTRODUCTION

The MC68HC05X16 microcomputer (MCU) is a member of Motorola's MC68HC05 family of low-cost single chip microcomputers. This 8-bit MCU contains an on-board controller area network module (MCAN), complete with interface circuitry, comprising output drivers, input comparators and a $V_{DD}/2$ generator. In addition, the device contains an on-chip oscillator, CPU, RAM, ROM, EEPROM, A/D converter, pulse length modulated outputs, I/O, serial communications interface, programmable timer system and watchdog. The fully static design allows operation at frequencies down to dc, reducing power consumption to a few micro-amps.

This data sheet is structured such that devices similar to the MC68HC05X16 are described in a set of appendices (see [Table 1-1](#)).

Table 1-1 Data sheet appendices

Device	Appendix	Differences from MC68HC05X16
MC68HC05X32	A	32K bytes ROM; increased RAM
MC68HC705X32	B	32K bytes EPROM; increased RAM; bootstrap firmware replaced
MC68HC05X32	C	32K bytes ROM; increased RAM; high speed operation

Note: [Appendix C](#) contains only electrical characteristics exclusive to the high speed operation of the MC68HC05X32. For all other information concerning this device, refer to [Appendix A](#).

1.1 Features

Hardware features

- Fully static design featuring the industry standard M68HC05 family CPU core
- On chip crystal oscillator with divide-by -2, -4, -8 or -10, or a software selectable divide-by -32, -64, -128 or -160 option (SLOW mode)
- 352 bytes of RAM
- 15102 bytes of user ROM plus 16 bytes of user vectors
- 256 bytes of byte erasable EEPROM with internal charge pump and security bit
- Write/erase protect bit for 224 of the 256 bytes EEPROM
- Bootstrap firmware
- Power saving STOP, WAIT and SLOW modes
- Three 8-bit parallel I/O ports and one 8-bit input-only port; wired-OR interrupt capability on all port B pins
- Motorola controller area network (MCAN) with line interface circuitry
- Software option available to output the internal E-clock to port pin PC2
- 16-bit timer with 2 input captures and 2 output compares
- Computer operating properly (COP) watchdog timer
- Serial communications interface system (SCI) with independent transmitter/receiver baud rate selection; receiver wake-up function for use in multi-receiver systems
- 8 channel A/D converter
- 2 pulse length modulation systems which can be used as D/A converters
- One interrupt request input plus 4 on-board hardware interrupt sources
- 2.2 MHz bus speed
- -40 to +125°C temperature range
- Available in 64-pin quad flat pack (QFP) package
- Complete development system support available using the MMDS05 or M68MMPFB0508 development station with the M68EML05X32 emulation module or the M68HC05XEVS evaluation system

1.2 Mask options for the MC68HC05X16

The MC68HC05X16 has six mask options that are programmed during manufacture and must be specified on the order form.

- Oscillator division ratio selection (divide-by-2, -4, -8 or -10)
- Oscillator start-up delay following power-on or STOP (t_{PORL}) = 16 or 4064 cycles
- Automatic watchdog enable/disable following a power-on or external reset
- Watchdog enable/disable during WAIT mode
- Wired-OR interrupt enable
- Resistive pull-downs on ports B and/or C

Note: It is recommended that an external clock is always used if t_{PORL} is set to 16 cycles. This will prevent any problems arising from oscillator stability when the device is put into STOP mode.

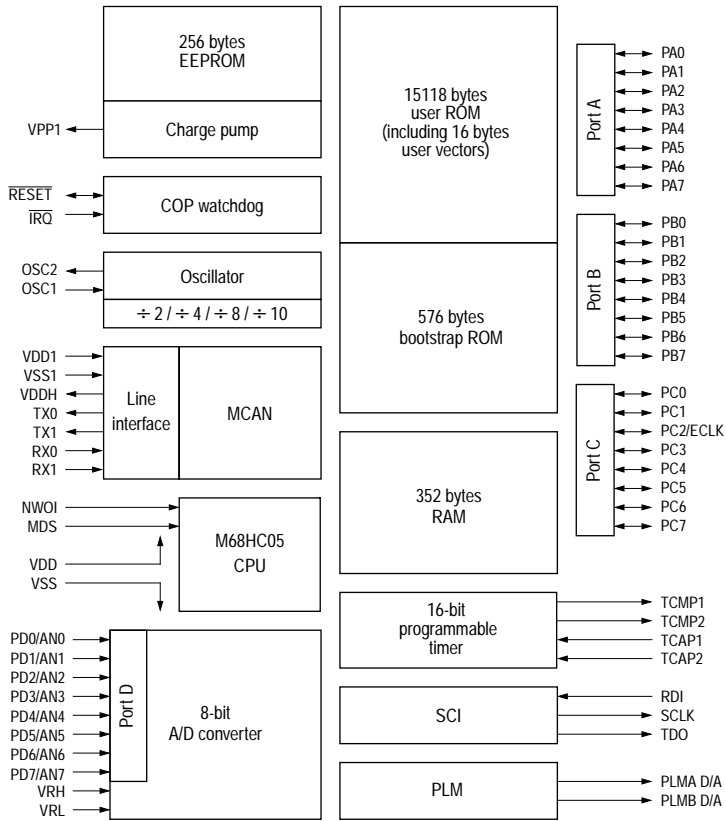

Figure 1-1 MC68HC05X16 block diagram

2

MODES OF OPERATION AND PIN DESCRIPTIONS

2.1 Modes of operation

The MC68HC05X16 MCU has two modes of operation, single-chip mode and bootstrap mode. In the MC68HC05X16 the single-chip mode is the normal user operating frequency [Table 2-1](#) shows the conditions required to enter each mode on the rising edge of $\overline{\text{RESET}}$.

Table 2-1 Mode of operation selection

MDS		IRQ	TCAP1	TCAP2	PD3	PD4	Mode
V_{SS}	AND	V_{SS} to V_{DD}	V_{SS} to V_{DD}	X	X	X	Single-chip
V_{DD}	OR	$2V_{DD}$	V_{SS}	X	0	0	Reserved for Motorola use
Bootstrap mode:							
V_{DD}	OR	$2V_{DD}$	V_{DD}	V_{SS}	1	1	Serial RAM loader
V_{DD}	OR	$2V_{DD}$	V_{DD}	V_{SS}	1	0	Jump to RAM + 1
V_{DD}	OR	$2V_{DD}$	V_{DD}	V_{SS}	0	1	Jump to any address

Note: On the rising edge of $\overline{\text{RESET}}$, holding the $\overline{\text{IRQ}}$ pin at $2 \times V_{DD}$ is equivalent to holding the MDS pin at V_{DD} . The device cannot enter single-chip mode unless MDS is tied to V_{SS} (or left floating) and IRQ is below V_{DD} .

2.1.1 Single-chip mode

This is the normal user operating mode of the MC68HC05X16. In this mode the device functions as a self-contained microcomputer (MCU) with all on-board peripherals, including the three 8-bit I/O ports and the 8-bit input-only port, available to the user. All address and data activity occurs within the MCU.

2.1.2 Bootstrap mode

To place the part in bootstrap mode, the following conditions must be met during transition of the RESET pin from low to high:

- 1) \overline{IRQ} pin at $2xV_{DD}$ OR MDS pin at V_{DD}
- 2) TCAP1 pin at V_{DD}
- 3) TCAP2 pin at V_{SS}

PD4 and PD3 are connected according to the values given in [Table 2-1](#) to select the device's function from the following three functions:

- Execute serial RAM loader program
- Jump to RAM + 1
- Jump to any address

If the SEC bit in the option register is set, on first entering bootstrap mode the RAM and the EEPROM are completely erased. The option register which contains the security bit is erased last, before any program can be executed. The bootstrap software is implemented in the following locations:

- RAM load and execute from \$03B0 to \$03FD
- Vectors and program select from \$7F80 to \$7FEF

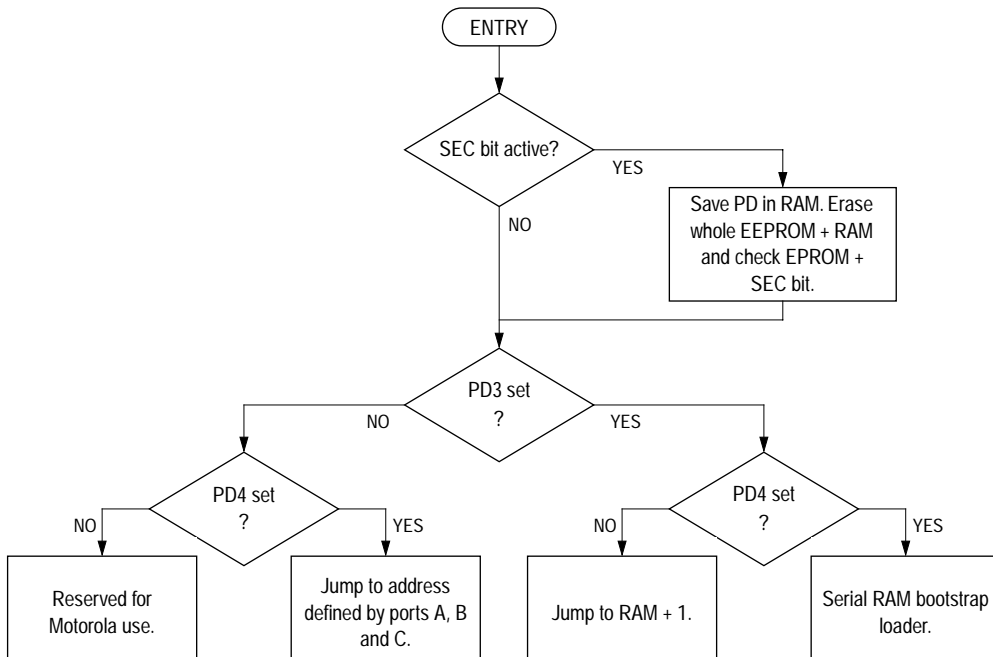

Figure 2-1 Bootstrap mode function selection flow chart

Note: Oscillator divide-by-two is forced in bootstrap mode; all other mask options are selected by the customer (see [Section 1.2](#)).

2.1.2.1 Serial RAM loader

In the 'load program in RAM and execute' routine, user programs are loaded into MCU RAM via the SCI port and then executed. Data is loaded sequentially, starting at RAM location \$0050, until the last byte is loaded. The first byte loaded is the count of the total number of bytes in the program plus the count byte. After completion of RAM loading, control can be transferred either to the second byte in RAM, \$0051, by executing a jump to RAM + 1 function, or it can be transferred to any address by executing a jump to any address function. During the firmware initialization stage, the SCI is configured for the NRZ data format (idle line, start bit, eight data bits and stop bit). The baud rate is 9600 with a 4 MHz crystal. A program to convert ASCII S-records to the format required by the RAM loader is available from Motorola.

When the last byte is loaded, the firmware halts operation expecting additional data to arrive. At this point, the reset switch is placed in the reset position which resets the MCU, but keeps the RAM program intact. All routines loaded in RAM can now be entered from this state, including the one which executes the program in RAM (see [Section 2.1.2.2](#) and [Section 2.1.2.3](#)).

To load a program in the EEPROM, the 'load program in RAM and execute' function is also used. In this instance the process involves two distinct steps. Firstly, the RAM is loaded with a program which controls the loading of the EEPROM, and when the RAM contents are executed, the MCU is instructed to load the EEPROM.

The erased state of the EEPROM is \$FF.

[Figure 2-3](#) shows the schematic diagram of the circuit required for the serial RAM loader.

2.1.2.2 Jump to RAM + 1

After the serial RAM loader program is completed this function can be used to execute a program loaded in RAM starting at the second RAM address, \$0051. It must be noted that the lowest RAM address, \$0050, is used by the RAM loader program to store the total number of bytes in the program.

2.1.2.3 'Jump to any address'

This function allows execution of programs previously loaded in RAM or EEPROM using the methods outlined in [Section 2.1.2.1](#).

To execute the 'jump to any address' function, data input at port A has to be \$CC and data input at port B and port C should represent the MSB and LSB respectively, of the address to jump to for execution of the user program. A schematic diagram of the circuit required is shown in [Figure 2-2](#).

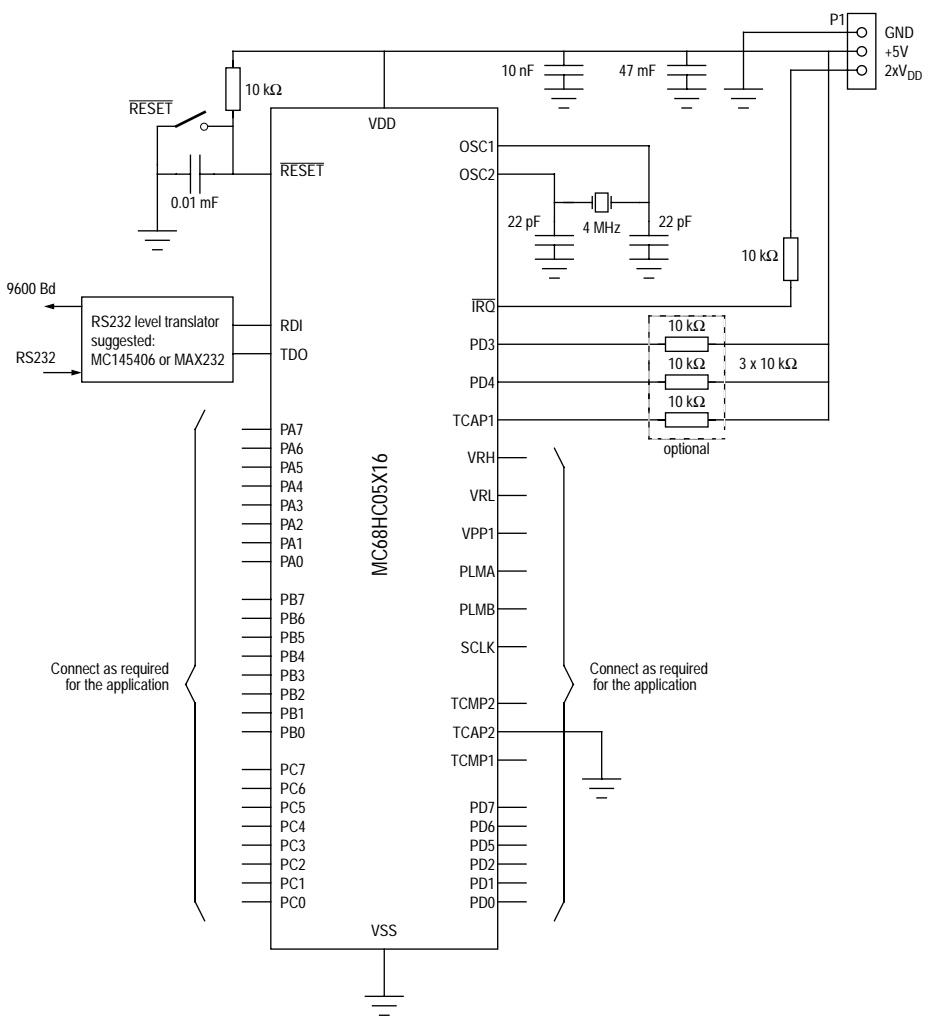

Figure 2-3 MC68HC05X16 'load program in RAM and execute' schematic diagram

2.2 Low power modes

The STOP and WAIT instructions have different effects on the programmable timer, the serial communications interface, the watchdog system, the EEPROM and the A/D converter. These different effects are described in the following sections.

2.2.1 STOP mode

The STOP instruction places the MCU in its lowest power consumption mode. In STOP mode, the internal oscillator is turned off (providing the MCAN is 'asleep', see [Section 5.5](#)) halting all internal processing including timer, serial communications interface and the A/D converter (see flow chart in [Figure 2-4](#)). The MCU will wake up from STOP mode only by receipt of an MCAN external interrupt or by the detection of a reset (logic low on $\overline{\text{RESET}}$ pin or a power-on reset).

The STOP instruction can be executed (i.e. the oscillator can be turned off) only when the MCAN module is in SLEEP mode. See [Section 5.5](#).

During STOP mode, the I-bit in the CCR is cleared to enable external interrupts (see [Section 11.1.5](#)). The SM bit is cleared to allow nominal speed operation for the 4064 cycles count while exiting STOP mode (see [Section 2.2.3](#)).

All other registers and memory remain unaltered and all input/output lines remain unchanged. This continues until a MCAN interrupt, wired-OR interrupt, external interrupt (IRQ) or reset is sensed, at which time the internal oscillator is turned on. The interrupt or reset causes the program counter to vector to the corresponding locations (\$3FFA, B and \$3FFE, F respectively).

When leaving STOP mode, a t_{PORL} internal cycles delay is provided to give the oscillator time to stabilise before releasing CPU operation. This delay is selectable via a mask option to be either 16 or 4064 cycles. The CPU will resume operation by servicing the interrupt that wakes it up, or by fetching the reset vector, if reset wakes it up.

Note: If t_{PORL} is selected to be 16 cycles, it is recommended that an external clock signal is used to avoid problems with oscillator stability while the device is in STOP mode. The stacking corresponding to an eventual interrupt to go out of STOP mode will only be executed when going out of STOP mode.

The following list summarizes the effect of STOP mode on the modules of the MC68HC05X16.

- The watchdog timer is reset; see [Section 10.1.4.1](#)
- The EEPROM acts as read-only memory (ROM); see [Section 3.6](#)
- All SCI activity stops; see [Section 7.13](#)
- The timer stops counting; see [Section 6.6](#)
- The PLM outputs remain at current levels; see [Section 8.3](#)
- The A/D converter is disabled; see [Section 9.3](#)
- The I-bit in the CCR is cleared

2.2.2 WAIT mode

The WAIT instruction places the MCU in a low power consumption mode, but WAIT mode consumes more power than STOP mode. All CPU action is suspended and the watchdog is disabled, but the timer, A/D and SCI and MCAN systems remain active and operate as normal (see flow chart in [Figure 2-4](#)). All other memory and registers remain unaltered and all parallel input/output lines remain unchanged. The programming or erase mechanism of the EEPROM is also unaffected, as well as the charge pump high voltage generator.

During WAIT mode the I-bit in the CCR is cleared to enable all interrupts. The INTE bit in the miscellaneous register ([Section 2.2.3.1](#)) is not affected by WAIT mode. When any interrupt or reset is sensed, the program counter vectors to the locations containing the start address of the interrupt or reset service routine.

Any interrupt or reset condition causes the processor to exit WAIT mode.

If an interrupt exit from WAIT mode is performed, the state of the remaining systems will be unchanged.

If a reset exit from WAIT mode is performed the entire system reverts to the disabled reset state.

Note: The stacking corresponding to an eventual interrupt to leave WAIT mode will only be executed when leaving WAIT mode.

The following list summarizes the effect of WAIT mode on the modules of the MC68HC05X16.

- The watchdog timer functions according to the mask option selected; see [Section 10.1.4.2](#)
- The EEPROM is not affected; see [Section 3.7](#)
- The SCI is not affected; see [Section 7.14](#)
- The timer is not affected; see [Section 6.7](#)
- The PLM is not affected; see [Section 8.4](#)
- The A/D converter is not affected; see [Section 9.4](#)
- The I-bit in the CCR is cleared
- The MCAN module is unaffected

2.2.2.1 Power consumption during WAIT mode

Power consumption during WAIT mode depends on how many systems are active. The power consumption will be highest when all the systems (A/D, timer, EEPROM, SCI and MCAN) are active, and lowest when the EEPROM erase and programming mechanism, SCI and A/D are disabled and the MCAN is in SLEEP mode. The timer cannot be disabled in WAIT mode. It is important that before entering WAIT mode, the programmer sets the relevant control bits for the individual modules to reflect the desired functionality during WAIT mode.

Power consumption may be further reduced by the use of SLOW mode. (See [Section 2.2.3](#)).

2.2.3 SLOW mode

The SLOW mode function is controlled by the SM bit in the miscellaneous register at location \$000C. It allows the user to insert, under software control, an extra divide-by-16 between the oscillator and the internal clock driver (see [Figure 2-5](#)). This feature allows all the internal operations to slow down and thus reduces power consumption.

Warning: The SLOW mode function should not be enabled while using the A/D converter or while erasing/programming the EEPROM unless the internal A/D RC oscillator is turned on.

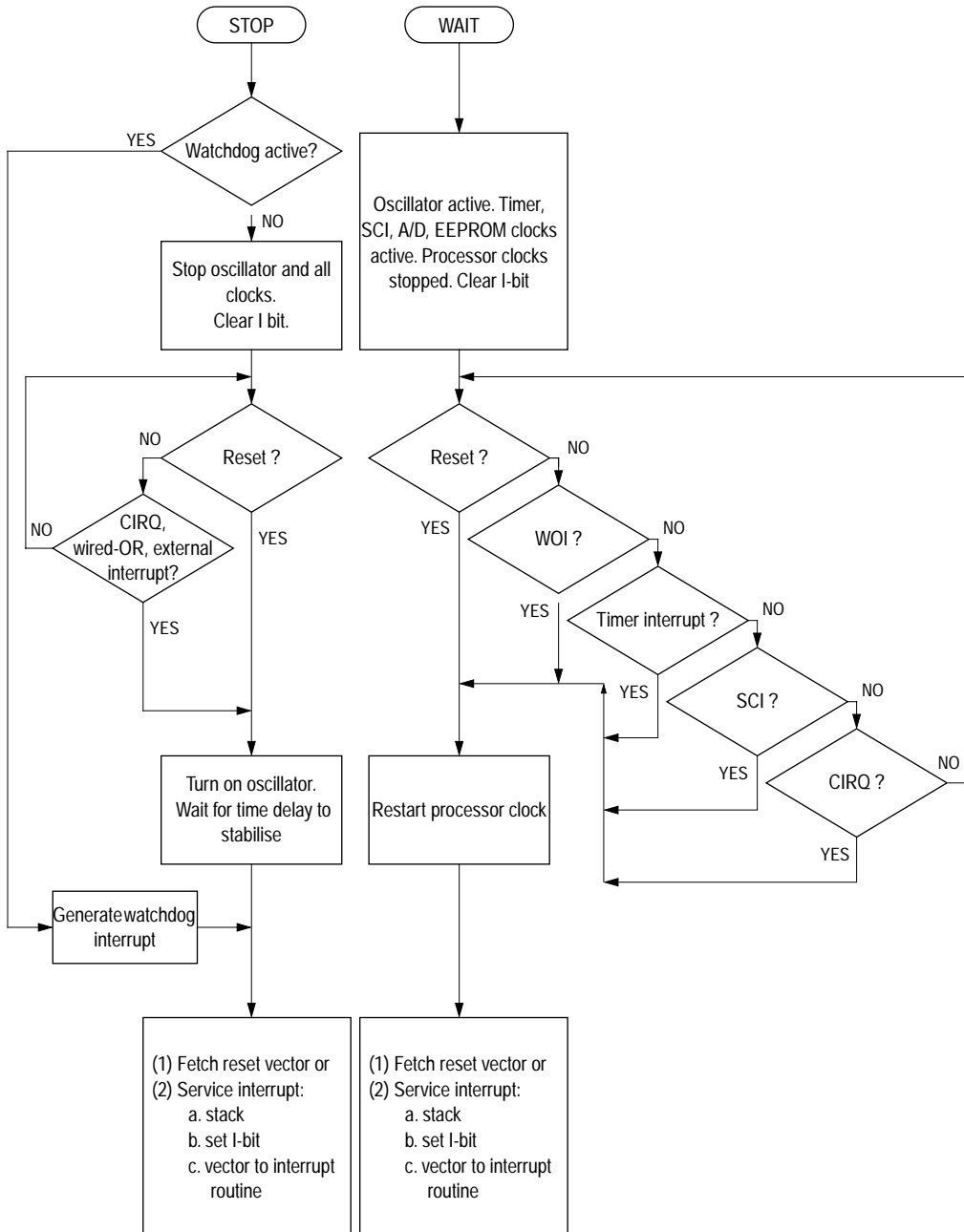
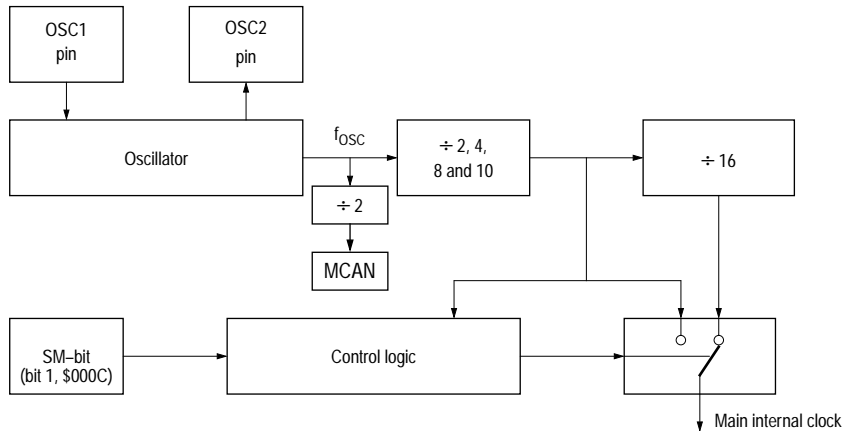

Figure 2-4 STOP and WAIT flow charts



Note: The MCAN module clock is unaffected during SLOW mode.

Figure 2-5 Slow mode divider block diagram

2.2.3.1 Miscellaneous register

	Address	bit 7	bit 6	bit 5	bit 4	bit 3	bit 2	bit 1	bit 0	State on reset
Miscellaneous	\$000C	POR	INTP	INTN	INTE	SFA	SFB	SM	WDOG	u001 000u

SM — Slow mode

- 1 (set) — The system runs at a bus speed 16 times lower than normal ($f_{OSC}/32$, $/64$, $/128$ or $/160$). SLOW mode affects all sections of the device (including SCI, A/D and timer) except for the MCAN module.
- 0 (clear) — The system runs at normal bus speed ($f_{OSC}/2$, $/4$, $/8$ or $/10$).

The SM bit is cleared by external or power-on reset. The SM bit is automatically cleared when entering STOP mode.

Note: The bits shown shaded in the above representation are explained individually in the relevant sections of this manual. The complete register plus an explanation of each bit can be found in [Section 3.8](#).

2.3 Pin descriptions

2.3.1 VDD and VSS

Power is supplied to the microcontroller using these two pins. VDD is the positive supply and VSS is ground.

It is in the nature of CMOS designs that very fast signal transitions occur on the MCU pins. These short rise and fall times place very high short-duration current demands on the power supply. To prevent noise problems, special care must be taken to provide good power supply bypassing at the MCU. Bypass capacitors should have good high-frequency characteristics and be as close to the MCU as possible. Bypassing requirements vary, depending on how heavily the MCU pins are loaded.

2.3.2 $\overline{\text{IRQ}}$

This is an input-only pin for external interrupt sources. Interrupt triggering is selected using the INTP and INTN bits in the miscellaneous register, to be one of four options detailed in [Table 10-3](#). In addition, the external interrupt facility ($\overline{\text{IRQ}}$) can be disabled using the INTE bit in the Miscellaneous register (see [Section 3.8](#)). It is only possible to change the interrupt option bits in the miscellaneous register while the I-bit is set. Selecting a different interrupt option will automatically clear any pending interrupts. Further details of the external interrupt procedure can be found in [Section 10.2.3.2](#).

The $\overline{\text{IRQ}}$ pin contains an internal Schmitt trigger as part of its input to improve noise immunity. A high voltage detector is provided on this pin to select modes of operation other than single-chip mode. See [Section 2.1](#).

2.3.3 $\overline{\text{RESET}}$

This active low I/O pin is used to reset the MCU. Applying a logic zero to this pin forces the device to a known start-up state. An external RC-circuit can be connected to this pin to generate a power-on reset (POR) if required. In this case, the time constant must be great enough (at least 100ms) to allow the oscillator circuit to stabilise. This input has an internal Schmitt trigger to improve noise immunity. When a reset condition occurs internally, i.e. from the COP watchdog, the $\overline{\text{RESET}}$ pin provides an active-low open drain output signal that may be used to reset external hardware.

2.3.4 MDS

A pull-down device is activated on this pin each time the $\overline{\text{RESET}}$ pin is pulled low. Even after the $\overline{\text{RESET}}$ pin is pulled high, the pull-down on the MDS pin will remain active until the pin is pulled high. In single-chip mode MDS can be connected to VSS or left floating. When MDS is tied to V_{DD} at the end of reset, it is used to select any mode of operation other than single-chip mode. This has the same effect as tying $\overline{\text{IRQ}}$ to $2V_{DD}$. See [Section 2.1](#).

Note: Although this pin can be left floating to select single-chip mode, it is advisable to hard-connect it to VSS, especially in an electrically noisy environment.

2.3.5 TCAP1

The TCAP1 input controls the input capture 1 function of the on-chip programmable timer system.

2.3.6 TCAP2

The TCAP2 input controls the input capture 2 function of the on-chip programmable timer system.

2.3.7 TCMP1

The TCMP1 pin is the output of the output compare 1 function of the timer system.

2.3.8 TCMP2

The TCMP2 pin is the output of the output compare 2 function of the timer system.

2.3.9 RDI (Receive data in)

The RDI pin is the input pin of the SCI receiver.

2.3.10 TDO (Transmit data out)

The TDO pin is the output pin of the SCI transmitter.

2.3.11 SCLK

The SCLK pin is the clock output pin of the SCI transmitter.

2.3.12 OSC1, OSC2

These pins provide control input for an on-chip oscillator circuit. A crystal, ceramic resonator or external clock signal connected to these pins supplies the oscillator clock. The oscillator frequency (f_{OSC}) is divided by two, four, eight or ten to give the internal bus frequency (f_{OP}). There is also a software option which introduces an additional divide by 16 into the oscillator clock, giving an internal bus frequency of $f_{OSC}/32$, $/64$, $/128$ or $/160$.

2.3.12.1 Crystal

The circuit shown in [Figure 2-6\(a\)](#) is recommended when using either a crystal or a ceramic resonator. An internal feedback resistor is provided on-chip between OSC1 and OSC2. [Figure 2-6\(d\)](#) lists the recommended capacitance values. The internal oscillator is designed to interface with an AT-cut parallel-resonant quartz crystal resonator in the frequency range specified for f_{OSC} (see [Section 12.4](#)). Use of an external CMOS oscillator is recommended when crystals outside the specified ranges are to be used. The crystal and associated components should be mounted as close as possible to the input pins to minimise output distortion and start-up stabilization time. The manufacturer of the particular crystal being considered should be consulted for specific information.

2.3.12.2 Ceramic resonator

A ceramic resonator may be used instead of a crystal in cost sensitive applications for frequencies up to 8MHz external. The circuit shown in [Figure 2-6\(a\)](#) is recommended when using either a crystal or a ceramic resonator. [Figure 2-6\(d\)](#) lists the recommended capacitance and feedback resistance values. The manufacturer of the particular ceramic resonator being considered should be consulted for specific information. This option is recommended only for applications that operate at an external clock frequency of 8MHz or less. Any application requiring an external operating frequency greater than 8MHz should use either a crystal oscillator or an external CMOS compatible clock source.

2.3.12.3 External clock

When using an external clock the OSC1 and OSC2 pins should be driven in antiphase, as shown in [Figure 2-6\(c\)](#). The t_{OXOV} or t_{LCH} specifications (see [Section 12.4](#)) do not apply when using an external clock input. The equivalent specification of the external clock source should be used in lieu of t_{OXOV} or t_{LCH} .

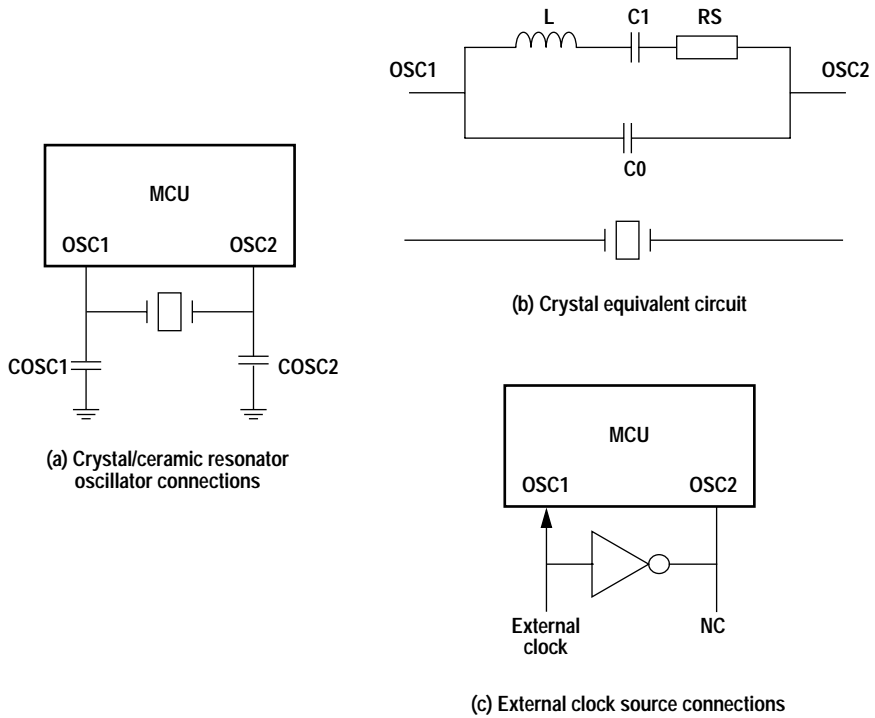

Crystal			
	2MHz	4MHz	Unit
$R_S(\text{max})$	400	75	Ω
C_0	5	7	pF
C_1	8	12	fF
C_{OSC1}	15 – 40	15 – 30	pF
C_{OSC2}	15 – 30	15 – 25	pF
Q	30 000	40 000	—

Ceramic resonator		
	2 – 4MHz	Unit
$R_S(\text{typ})$	10	Ω
C_0	40	pF
C_1	4.3	pF
C_{OSC1}	30	pF
C_{OSC2}	30	pF
Q	1250	—

(d) Typical crystal and ceramic resonator parameters

Figure 2-6 Oscillator connections

2.3.12.4 Oscillator division

The external oscillator can run up to 22MHz. For this reason an additional clock predivider is provided; its division ratio is selected via a mask option (see [Section 1.2](#)). This allows a CPU clock two, four, eight or ten times slower than the external clock, provided that SLOW mode has not been entered. If the device is in SLOW mode, a further divide-by-16 oscillator predivider reduces the CPU clock frequency to a frequency 32, 64, 128 or 160 times slower than the oscillator clock. The MCAN is directly clocked with the external oscillator frequency divided by two. A block diagram of the oscillator divider circuit is given in [Figure 2-7](#).

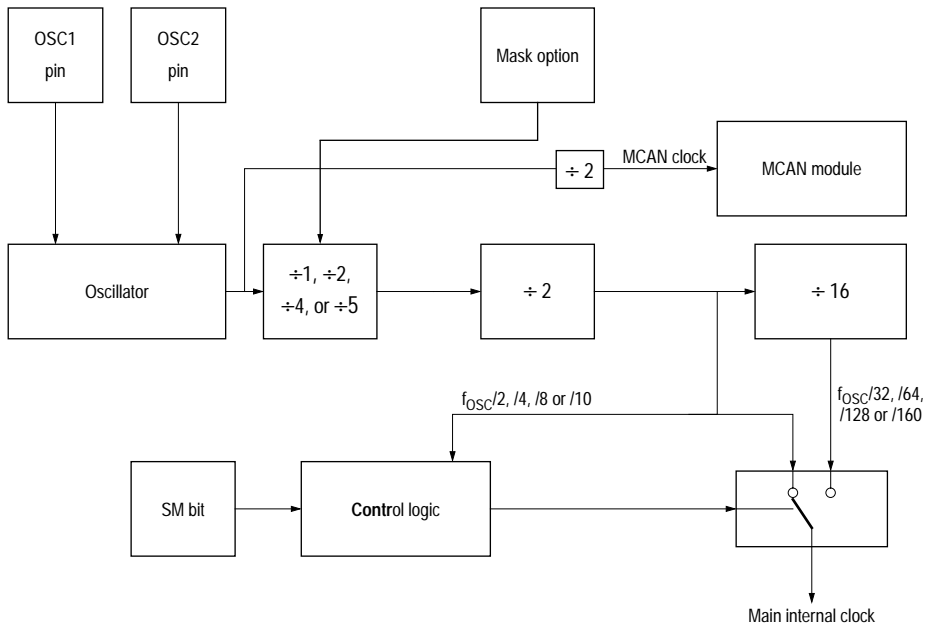

Figure 2-7 Oscillator divider block diagram

2.3.13 PLMA

The PLMA pin is the output of pulse length modulation converter A.

2.3.14 PLMB

The PLMB pin is the output of pulse length modulation converter B.

2.3.15 VPP1

The VPP1 pin is the output of the charge pump for the EEPROM1 array.

2.3.16 VRH

The VRH pin is the positive reference voltage for the A/D converter.

2.3.17 VRL

The VRL pin is the negative reference voltage for the A/D converter.

2.3.18 PA0 – PA7/PB0 – PB7/PC0 – PC7

These 24 I/O lines comprise ports A, B and C. The state of any pin is software programmable, and all the pins are configured as inputs during power-on or reset.

Under software control the PC2 pin can output the internal E-clock (see [Section 4.2](#)).

Resistive pull downs are provided on port B and/or port C and can be enabled via a mask option (see [Section 1.2](#)). Wired-OR interrupt capability is provided on all pins of port B (see [Section 10.2.3.3](#)).

2.3.19 NWOI

This pin provides another wired-OR interrupt capability in addition to port B. Wired-OR interrupts are requested when this pin is pulled high (if wired-OR interrupts are enabled), i.e. interrupt sensitivity on this pin is complementary to sensitivity on the $\overline{\text{IRQ}}$ pin (see [Table 10-3](#) in [Section 10.2.3.1](#)). When this pin is not in use it is recommended that it be tied to V_{SS} in noisy conditions. It is not necessary to tie NWOI to V_{SS} when there is a negligible amount of noise present.

2.3.20 PD0/AN0–PD7/AN7

This 8-bit input only port (D) shares its pins with the A/D converter. When enabled, the A/D converter uses pins PD0/AN0 – PD7/AN7 as its analog inputs. On reset, the A/D converter is disabled which forces the port D pins to be input only port pins (see [Section 9.5](#)).

2.3.21 VDD1

This pin is the power input for the input comparator of the MCAN module.

2.3.22 VSS1

This pin is the ground connection for the input comparator of the MCAN bus.

2.3.23 VDDH

This pin provides the high voltage reference output for the MCAN bus. The output voltage is equal to $VDD \div 2$.

2.3.24 RX0/RX1

These input pins connect the physical bus lines to the input comparator (receive). When the MCAN is in SLEEP mode, a dominant level on these pins will wake it up.

2.3.25 TX0/TX1

These output pins connect the output drivers of the MCAN bus to the physical bus lines (transmit).

MCAN bus lines. The bus can have one of two complementary values: dominant or recessive. During simultaneous transmission of dominant and recessive bits the resulting bus value will be dominant. For example with a positive logic wired-AND implementation of the bus, the dominant level would correspond to a logic 0 and the recessive level to a logic 1.

THIS PAGE LEFT BLANK INTENTIONALLY

3

MEMORY AND REGISTERS

The MC68HC05X16 MCU is capable of addressing 16384 bytes of memory and registers with its program counter. The memory map includes 15118 bytes of user ROM (including user vectors), 576 bytes of bootstrap ROM, 352 bytes of RAM and 256 bytes of EEPROM.

3.1 Registers

All the I/O, control and status registers of the MC68HC05X16 are contained within the first 32-byte block of the memory map, as shown in [Figure 3-1](#). MCAN registers are contained in the next 30 bytes of memory.

The miscellaneous register is shown in [Section 3.8](#) as this register contains bits which are relevant to several modules.

3.2 RAM

The user RAM comprises 176 bytes of memory, from \$0050 to \$00FF. This is shared with a 64 byte stack area. The stack begins at \$00FF and may extend down to \$00C0. The user RAM also comprises 176 bytes from \$0250 to \$02FF which is completely free for the user.

Note: Using the stack area for data storage or temporary work locations requires care to prevent the data from being overwritten due to stacking from an interrupt or subroutine call.

3.3 ROM

The user ROM consists of 15118 bytes of ROM mapped as follows:

- 15102 bytes of user ROM from \$0300 to \$3DFD
- 16 bytes of user vectors from \$3FF0 to \$3FFF

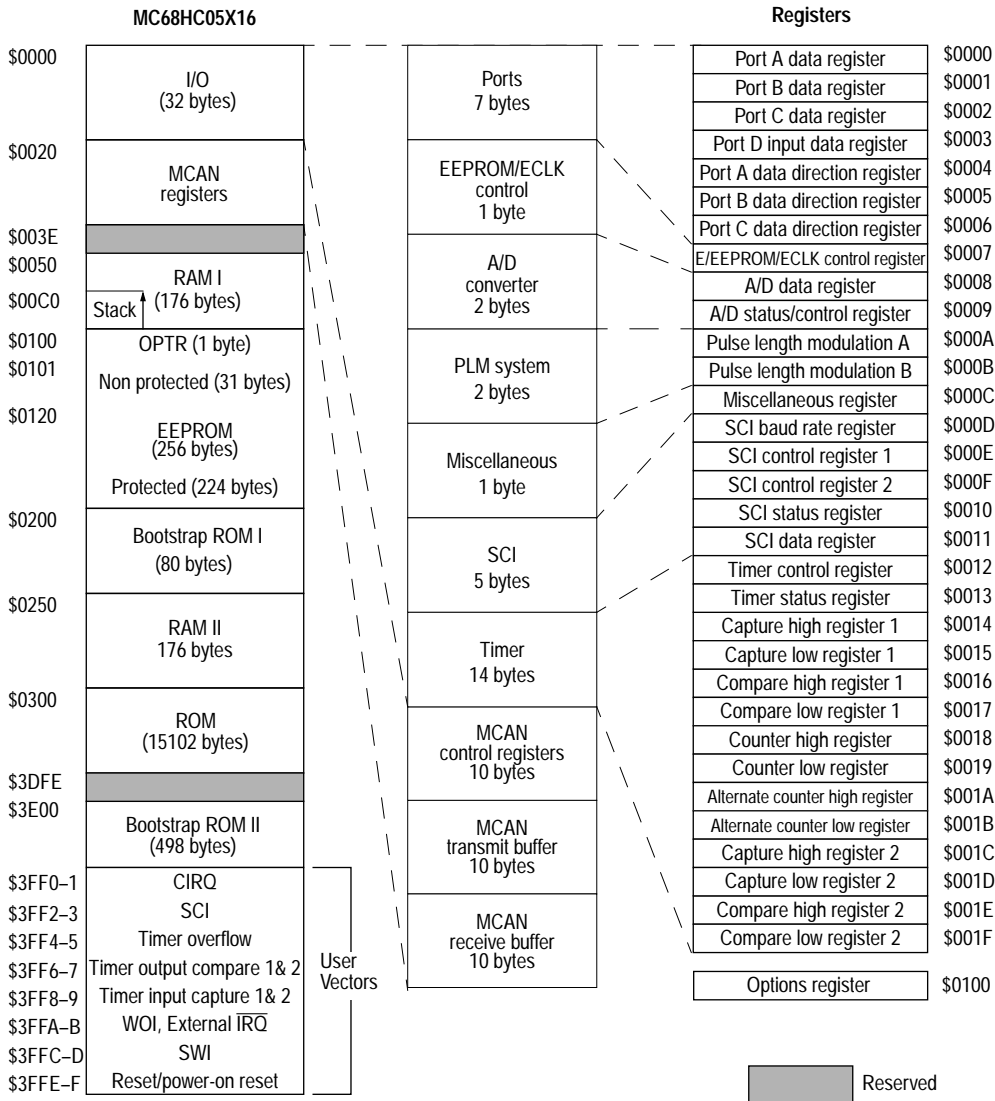

Figure 3-1 Memory map of the MC68HC05X16

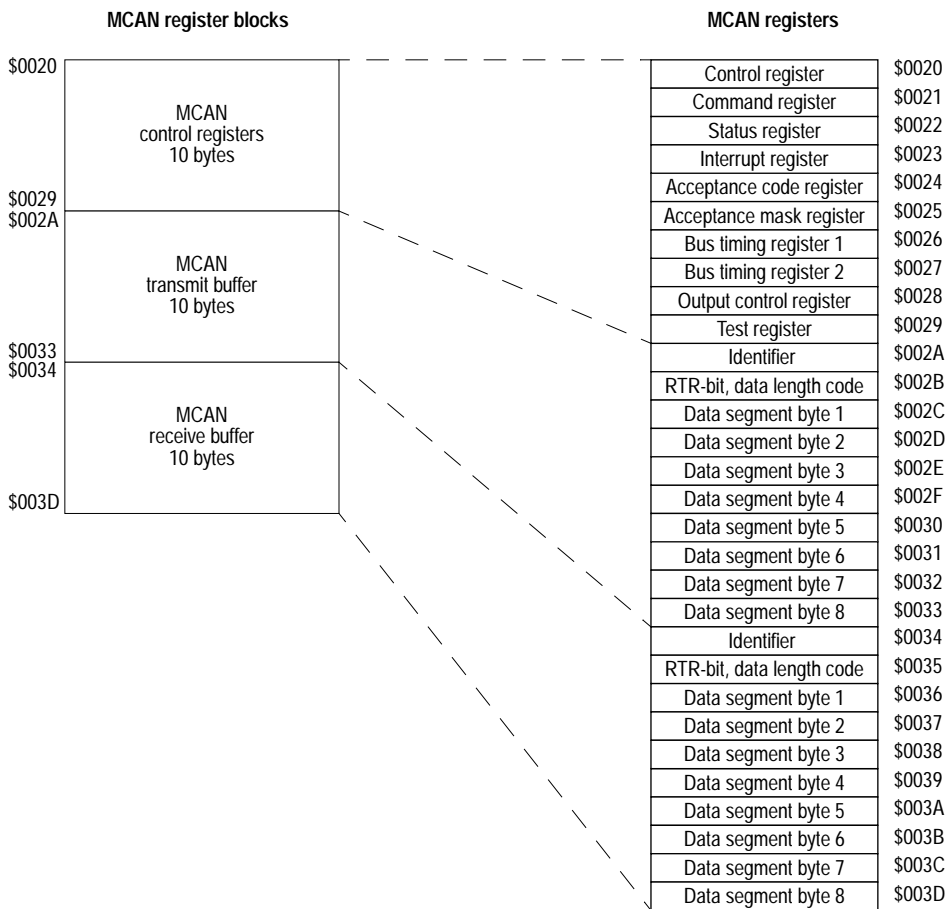

Figure 3-2 MCAN module memory map

3.4 Bootstrap ROM

There are two areas of bootstrap ROM (ROMI and ROMII) located from \$0200 to \$024F (80 bytes) and \$3DFE to \$3FEF (498 bytes) respectively.

3.5 EEPROM

The user EEPROM consists of 256 bytes of memory located from address \$0100 to \$01FF. 255 bytes are general purpose and 1 byte is used by the option register. The non-volatile EEPROM is byte erasable.

An internal charge pump provides the EEPROM voltage (V_{PP1}), which removes the need to supply a high voltage for erase and programming functions. The charge pump is a capacitor/diode ladder network which will give a very high impedance output of around 20-30 M Ω . The voltage of the charge pump is visible at the VPP1 pin. During normal operation of the device, where programming/erasing of the EEPROM array will occur, VPP1 should never be connected to either VDD or VSS as this could prevent the charge pump reaching the necessary programming voltage. Where it is considered dangerous to leave VPP1 unconnected for reasons of excessive noise in a system, it may be tied to V_{DD} ; this will protect the EEPROM data but will also increase power consumption, and therefore it is recommended that the protect bit function is used for regular protection of EEPROM data (see [Section 3.5.5](#)).

In order to achieve a higher degree of security for stored data, there is no capability for bulk or row erase operations.

The EEPROM control register (\$0007) provides control of the EEPROM programming and erase operations.

Warning: The VPP1 pin should never be connected to VSS, as this could cause permanent damage to the device.

3.5.1 EEPROM control register

	Address	bit 7	bit 6	bit 5	bit 4	bit 3	bit 2	bit 1	bit 0	State on reset
EEPROM/ECLK control	\$0007	WOIE	CAF	0	0	ECLK	E1ERA	E1LAT	E1PGM	0000 0000

WOIE — Wired-OR interrupt enable

This bit is used to enable wired-OR interrupts on the NWOI pin and on all port B pins which have been programmed as inputs. Wired-OR interrupts can only be enabled if the WOI mask option is selected (see [Section 1.2](#)). WOIE is forced to zero if this mask option is not selected. Power-on reset clears the WOIE bit.

- 1 (set) – Wired-OR interrupts are enabled (provided that wired-OR interrupts have been selected as a mask option).
- 0 (clear) – Wired-OR interrupts are disabled.

CAF — MCAN asleep flag

This flag is set by the MCU when the MCAN module enters SLEEP mode. This is the only indication that the MCAN is asleep (see [Section 5.5](#)). The bit is cleared when the MCAN wakes up.

- 1 (set) – The MCAN module is in SLEEP mode.
- 0 (clear) – The MCAN module is not in SLEEP mode.

ECLK — External clock option bit

See [Section 4.3](#) for a description of this bit.

E1ERA — EEPROM erase/programming bit

Providing the E1LAT and E1PGM bits are at logic one, this bit indicates whether the access to the EEPROM is for erasing or programming purposes.

- 1 (set) – An erase operation will take place.
- 0 (clear) – A programming operation will take place.

Once the program/erase EEPROM address has been selected, E1ERA cannot be changed.

E1LAT — EEPROM programming latch enable bit

- 1 (set) – Address and data can be latched into the EEPROM for further program or erase operations, providing the E1PGM bit is cleared.
- 0 (clear) – Data can be read from the EEPROM. The E1ERA bit and the E1PGM bit are reset to zero when E1LAT is '0'.

STOP, power-on and external reset clear the E1LAT bit.

Note: After the $t_{\text{ERA}1}$ erase time or $t_{\text{PROG}1}$ programming time, the E1LAT bit has to be reset to zero in order to clear the E1ERA bit and the E1PGM bit.

E1PGM — EEPROM charge pump enable/disable

- 1 (set) – Internal charge pump generator switched on.
- 0 (clear) – Internal charge pump generator switched off.

When the charge pump generator is on, the resulting high voltage is applied to the EEPROM array. This bit cannot be set before the data is selected, and once this bit has been set it can only be cleared by clearing the E1LAT bit.

A summary of the effects of setting/clearing bits 0, 1 and 2 of the control register are give in [Table 3-1](#).

Note: Not all combinations are shown in [Table 3-1](#), since the E1PGM and E1ERA bits are cleared when the E1LAT bit is at zero, resulting in a read condition.

Table 3-1 EEPROM control bits description

E1ERA	E1LAT	E1PGM	Description
0	0	0	Read condition
0	1	0	Ready to load address/data for program/erase
0	1	1	Byte programming in progress
1	1	0	Ready for byte erase (load address)
1	1	1	Byte erase in progress

3.5.2 EEPROM read operation

To be able to read from EEPROM, the E1LAT bit has to be at logic zero, as shown in [Table 3-1](#). While this bit is at logic zero, the E1PGM bit and the E1ERA bit are permanently reset to zero and the 256 bytes of EEPROM may be read as if it were a normal ROM area. The internal charge pump generator is automatically switched off since the E1PGM bit is reset.

If a read operation is executed while the E1LAT bit is set (erase or programming sequence), data resulting from the operation will be \$FF.

Note: When not performing any programming or erase operation, it is recommended that EEPROM should remain in the read mode (E1LAT = 0)

3.5.3 EEPROM erase operation

To erase the contents of a byte of the EEPROM, the following steps should be taken:

- 1 Set the E1LAT bit.
- 2 Set the E1ERA bit (1& 2 may be done simultaneously with the same instruction).
- 3 Write address/data to the EEPROM address to be erased.
- 4 Set the E1PGM bit.
- 5 Wait for a time t_{ERA1} .
- 6 Reset the E1LAT bit (to logic zero).

While an erase operation is being performed, any access of the EEPROM array will not be successful.

The erased state of the EEPROM is \$FF and the programmed state is \$00.

Note: Data written to the address to be erased is not used, therefore its value is not significant.

If a second word is to be erased, it is important that the E1LAT bit be reset before restarting the erasing sequence, otherwise any write to a new address will have no effect. This condition provides a higher degree of security for the stored data.

User programs must be running from the RAM or ROM as the EEPROM will have its address and data buses latched.

3.5.4 EEPROM programming operation

To program a byte of EEPROM, the following steps should be taken:

- 1 Set the E1LAT bit.
- 2 Write address/data to the EEPROM address to be programmed.
- 3 Set the E1PGM bit.
- 4 Wait for time t_{PROG1} .
- 5 Reset the E1LAT bit (to logic zero).

While a programming operation is being performed, any access of the EEPROM array will not be successful.

Warning: To program a byte correctly, it has to have been previously erased.

If a second word is to be programmed, it is important that the E1LAT bit be reset before restarting the programming sequence otherwise any write to a new address will have no effect. This condition provides a higher degree of security for the stored data.

User programs must be running from the RAM or ROM as the EEPROM will have its address and data buses latched.

Note: 224 bytes of EEPROM (address \$0120 to \$01FF) can be program and erase protected under the control of bit 1 of the OPTR register detailed in [Section 3.5.5](#).

3.5.5 Options register (OPTR)

This register (OPTR), located at \$0100, contains the secure and protect functions for the EEPROM and allows the user to select options in a non-volatile manner. The contents of the OPTR register are loaded into data latches with each power-on or external reset.

	Address	bit 7	bit 6	bit 5	bit 4	bit 3	bit 2	bit 1	bit 0	State on reset
Options (OPTR) ⁽¹⁾	\$0100							EE1P	SEC	Not affected

(1) This register is implemented in EEPROM; therefore reset has no effect on the individual bits.

EE1P – EEPROM protect bit

In order to achieve a higher degree of protection, the EEPROM is effectively split into two parts, both working from the VPP1 charge pump. Part 1 of the EEPROM array (32 bytes from \$0100 to \$011F) cannot be protected; part 2 (224 bytes from \$0120 to \$01FF) is protected by the EE1P bit of the options register.

- 1 (set) – Part 2 of the EEPROM array is not protected; all 256 bytes of EEPROM can be accessed for any read, erase or programming operations
- 0 (clear) – Part 2 of the EEPROM array is protected; any attempt to erase or program a location will be unsuccessful

When this bit is set (erased), the protection will remain until the next power-on or external reset. EE1P can only be written to '0' when the ELAT bit in the EEPROM control register is set.

SEC – Security bit

This high security bit allows the user to secure the EEPROM data from external accesses. When the SEC bit is at '0', the EEPROM contents are secured by preventing any entry to test mode. The only way to erase the SEC bit to '1' externally is to enter bootstrap mode, at which time the entire EEPROM contents will be erased. When the SEC bit is changed, its new value will have no effect until the next external or power-on reset.

3.6 EEPROM during STOP mode

When entering STOP mode, the EEPROM is automatically set to the read mode and the VPP1 high voltage charge pump generator is automatically disabled.

3.7 EEPROM during WAIT mode

The EEPROM is not affected by WAIT mode. Any program/erase operation will continue as in normal operating mode. The charge pump is not affected by WAIT mode, therefore it is possible to wait the t_{ERA1} erase time or t_{PROG1} programming time in WAIT mode.

Under normal operating conditions, the charge pump generator is driven by the internal CPU clocks. When the operating frequency is low, e.g. during slow mode (see [Figure 3.8](#)) or during WAIT mode, the clocking should be done by the internal A/D RC oscillator. The RC oscillator is enabled by setting the ADRC bit of the A/D status/control register at \$0009.

Table 3-2 MC68HC05X16 register outline

Register name	Address	bit 7	bit 6	bit 5	bit 4	bit 3	bit 2	bit 1	bit 0	State on reset
Port A data (PORTA)	\$0000									Undefined
Port B data (PORTB)	\$0001									Undefined
Port C data (PORTC)	\$0002						PC2/ ECLK			Undefined
Port D data (PORTD)	\$0003	PD7	PD6	PD5	PD4	PD3	PD2	PD1	PD0	Undefined
Port A data direction (DDRA)	\$0004									0000 0000
Port B data direction (DDRB)	\$0005									0000 0000
Port C data direction (DDRC)	\$0006									0000 0000
EEPROM/ECLK control	\$0007	WOIE	CAF	0	0	ECLK	E1ERA	E1LAT	E1PGM	0000 0000
A/D data (ADDATA)	\$0008									0000 0000
A/D status/control (ADSTAT)	\$0009	COCO	ADRC	ADON	0	CH3	CH2	CH1	CH0	0000 0000
Pulse length modulation A (PLMA)	\$000A									0000 0000
Pulse length modulation B (PLMB)	\$000B									0000 0000
Miscellaneous	\$000C	POR ⁽¹⁾	INTP	INTN	INTE	SFA	SFB	SM	WDOG ⁽²⁾	u001 000u
SCI baud rate (BAUD)	\$000D	SPC1	SPC0	SCT1	SCT0	SCT0	SCR2	SCR1	SCR0	00uu uuuu
SCI control 1 (SCCR1)	\$000E	R8	T8		M	WAKE	CPOL	CPHA	LBCL	Undefined
SCI control 2 (SCCR2)	\$000F	TIE	TCIE	RIE	ILIE	TE	RE	RWU	SBK	0000 0000
SCI status (SCSR)	\$0010	TDRE	TC	RDRF	IDLE	OR	NF	FE		1100 000u
SCI data (SCDR)	\$0011									0000 0000
Timer control (TCR)	\$0012	ICIE	OCIE	TOIE	FOLV2	FOLV1	OLV2	IEDG1	OLVL1	0000 000u
Timer status (TSR)	\$0013	ICF1	OCF1	TOF	ICF2	OCF2				Undefined
Input capture high 1	\$0014									Undefined
Input capture low 1	\$0015									Undefined
Output compare high 1	\$0016									Undefined
Output compare low 1	\$0017									Undefined
Timer counter high	\$0018									1111 1111
Timer counter low	\$0019									1111 1100
Alternate counter high	\$001A									1111 1111
Alternate counter low	\$001B									1111 1100
Input capture high 2	\$001C									Undefined
Input capture low 2	\$001D									Undefined
Output compare high 2	\$001E									Undefined
Output compare low 2	\$001F									Undefined
Options (OPTR) ⁽³⁾	\$0100							EE1P	SEC	Not affected

(1) The POR bit is set each time there is a power-on reset.

(2) The state of the WDOG bit after reset is dependent on the mask option selected: 1=watchdog enabled, 0=watchdog disabled.

(3) This register is implemented in EEPROM; therefore reset has no effect on the individual bits.

Table 3-3 MCAN register outline

Register name	Address	bit 7	bit 6	bit 5	bit 4	bit 3	bit 2	bit 1	bit 0	State on reset
Control (CCNTRL)	\$0020	MODE	SPD		OIE	EIE	TIE	RIE	RR	0u - u uu01
Command (CCOM)	\$0021	RX0	RX1	COMPSEL	SLEEP	COS	RRB	AT	TR	00u0 0000
Status (CSTAT)	\$0022	BS	ES	TS	RS	TCS	TBA	DO	RBS	uu00 1100
Interrupt (CINT)	\$0023				WIF	OIF	EIF	TIF	RIF	- - - 0 0000
Acceptance code (CACCC) ⁽¹⁾	\$0024	AC7	AC6	AC5	AC4	AC3	AC2	AC1	AC0	Undefined
Acceptance mask (CACM) ⁽¹⁾	\$0025	AM7	AM6	AM5	AM4	AM3	AM2	AM1	AM0	Undefined
Bus timing 0 (CBT0) ⁽¹⁾	\$0026	SJW1	SJW0	BRP5	BRP4	BRP3	BRP2	BRP1	BRP0	Undefined
Bus timing 1 (CBT1) ⁽¹⁾	\$0027	SAMP	TSEG22	TSEG21	TSEG20	TSEG13	TSEG12	TSEG11	TSEG10	Undefined
Output control (COCNTRL) ⁽¹⁾	\$0028	OCTP1	OCTN1	OCPOL1	OCTP0	OCTN0	OCPOL0	OCM1	OCM0	Undefined
(reserved)	\$0029									
Transmit buffer identifier (TBI)	\$002A	ID10	ID9	ID8	ID7	ID6	ID5	ID4	ID3	Undefined
RTR-bit, data length code (TRTDL)	\$002B	ID2	ID1	ID0	RTR	DLC3	DLC2	DLC1	DLC0	Undefined
Transmit data segment 1 (TDS1)	\$002C	DB7	DB6	DB5	DB4	DB3	DB2	DB1	DB0	Undefined
Transmit data segment 2 (TDS2)	\$002D	DB7	DB6	DB5	DB4	DB3	DB2	DB1	DB0	Undefined
Transmit data segment 3 (TDS3)	\$002E	DB7	DB6	DB5	DB4	DB3	DB2	DB1	DB0	Undefined
Transmit data segment 4 (TDS4)	\$002F	DB7	DB6	DB5	DB4	DB3	DB2	DB1	DB0	Undefined
Transmit data segment 5 (TDS5)	\$0030	DB7	DB6	DB5	DB4	DB3	DB2	DB1	DB0	Undefined
Transmit data segment 6 (TDS6)	\$0031	DB7	DB6	DB5	DB4	DB3	DB2	DB1	DB0	Undefined
Transmit data segment 7 (TDS7)	\$0032	DB7	DB6	DB5	DB4	DB3	DB2	DB1	DB0	Undefined
Transmit data segment 8 (TDS8)	\$0033	DB7	DB6	DB5	DB4	DB3	DB2	DB1	DB0	Undefined
Receive buffer identifier (RBI)	\$0034	ID10	ID9	ID8	ID7	ID6	ID5	ID4	ID3	Undefined
RTR-bit, data length code (RRTDL)	\$0035	ID2	ID1	ID0	RTR	DLC3	DLC2	DLC1	DLC0	Undefined
Receive data segment 1 (RDS1)	\$0036	DB7	DB6	DB5	DB4	DB3	DB2	DB1	DB0	Undefined
Receive data segment 2 (RDS2)	\$0037	DB7	DB6	DB5	DB4	DB3	DB2	DB1	DB0	Undefined
Receive data segment 3 (RDS3)	\$0038	DB7	DB6	DB5	DB4	DB3	DB2	DB1	DB0	Undefined
Receive data segment 4 (RDS4)	\$0039	DB7	DB6	DB5	DB4	DB3	DB2	DB1	DB0	Undefined
Receive data segment 5 (RDS5)	\$003A	DB7	DB6	DB5	DB4	DB3	DB2	DB1	DB0	Undefined
Receive data segment 6 (RDS6)	\$003B	DB7	DB6	DB5	DB4	DB3	DB2	DB1	DB0	Undefined
Receive data segment 7 (RDS7)	\$003C	DB7	DB6	DB5	DB4	DB3	DB2	DB1	DB0	Undefined
Receive data segment 8 (RDS8)	\$003D	DB7	DB6	DB5	DB4	DB3	DB2	DB1	DB0	Undefined

(1) These registers can only be accessed when the reset request bit in the control register is set.

3.8 Miscellaneous register

	Address	bit 7	bit 6	bit 5	bit 4	bit 3	bit 2	bit 1	bit 0	State on reset
Miscellaneous	\$000C	POR ⁽¹⁾	INTP	INTN	INTE	SFA	SFB	SM	WDOG ⁽²⁾	u001 000u

(1) The POR bit is set each time there is a power-on reset.

(2) The state of the WDOG bit after reset is dependent on the mask option selected; 1=watchdog enabled, 0=watchdog disabled.

POR — Power-on reset bit (see Section 10.1)

This bit is set each time the device is powered on. Therefore, the state of the POR bit allows the user to make a software distinction between a power-on and an external reset. This bit cannot be set by software and is cleared by writing it to zero.

- 1 (set) – A power-on reset has occurred.
- 0 (clear) – No power-on reset has occurred.

INTP, INTN — External interrupt sensitivity options (see Section 10.2)

These two bits allow the user to select which edge the \overline{IRQ} pin and WOI will be sensitive to (see Table 3-4). Both bits can be written to only while the I-bit is set, and are cleared by power-on or external reset, thus the device is initialised with negative edge and low level sensitivity.

Table 3-4 \overline{IRQ} and WOI sensitivity

INTP	INTN	\overline{IRQ} sensitivity	WOI interrupt options
0	0	Negative edge and low level sensitive	Positive edge and high level sensitive
0	1	Negative edge only	Positive edge only
1	0	Positive edge only	Negative edge only
1	1	Positive and negative edge sensitive	Positive and negative edge sensitive

INTE — External interrupt enable (see Section 10.2)

- 1 (set) – External interrupt function (\overline{IRQ}) enabled.
- 0 (clear) – External interrupt function (\overline{IRQ}) disabled.

The INTE bit can be written to only while the I-bit is set, and is set by power-on or external reset, thus enabling the external interrupt function.

SFA — Slow or fast mode selection for PLMA (see Section 8.1)

- 1 (set) – Slow mode PLMA (4096 x timer clock period).
- 0 (clear) – Fast mode PLMA (256 x timer clock period).

SFB — Slow or fast mode selection for PLMB (see [Section 8.1](#))

- 1 (set) – Slow mode PLMB (4096 x timer clock period).
- 0 (clear) – Fast mode PLMB (256 x timer clock period).

Note: The highest speed of the PLM system corresponds to the frequency of the TOF bit being set, multiplied by 256. The lowest speed of the PLM system corresponds to the frequency of the TOF bit being set, multiplied by 16.

Warning: Because the SFA bit and SFB bit are not double buffered, it is mandatory to set the SFA bit and the SFB bit to the desired values before writing to the PLM registers; not doing so could temporarily give incorrect values at the PLM outputs.

SM — Slow mode (see [Section 2.2.3](#))

- 1 (set) – The system runs at a bus speed 16 times lower than normal ($f_{OSC}/32$). SLOW mode affects all sections of the device, including SCI, A/D and timer.
- 0 (clear) – The system runs at normal bus speed ($f_{OSC}/2$).

The SM bit is cleared by external or power-on reset. The SM bit is automatically cleared when entering STOP mode.

WDOG — Watchdog enable/disable (see [Section 10.1.4](#))

The WDOG bit can be used to enable the watchdog timer previously disabled by a mask option. Following a watchdog reset the state of the WDOG bit is as defined by the mask option specified.

- 1 (set) – Watchdog counter cleared and enabled.
- 0 (clear) – The watchdog cannot be disabled by software; writing a zero to this bit has no effect.

4

INPUT/OUTPUT PORTS

In single-chip mode, the MC68HC05X16 has a total of 24 I/O lines, arranged as three 8-bit ports (A, B and C), and eight input-only lines, arranged as one 8-bit port (D). Each I/O line is individually programmable as either input or output, under the software control of the data direction registers. The 8-bit input-only port (D) shares its pins with the A/D converter, when the A/D converter is enabled. To avoid glitches on the output pins, data should be written to the I/O port data register before writing ones to the corresponding data direction register bits to set the pins to output mode.

4.1 Input/output programming

The bidirectional port lines may be programmed as inputs or outputs under software control. The direction of each pin is determined by the state of the corresponding bit in the port data direction register (DDR). Each port has an associated DDR. Any I/O port pin is configured as an output if its corresponding DDR bit is set to a logic one. A pin is configured as an input if its corresponding DDR bit is cleared to a logic zero.

At power-on or reset, all DDRs are cleared, thus configuring all port pins as inputs. The data direction registers can be written to or read by the MCU. During the programmed output state, a read of the data register actually reads the value of the output data latch and not the I/O pin. The operation of the standard port hardware is shown schematically in [Figure 4-1](#).

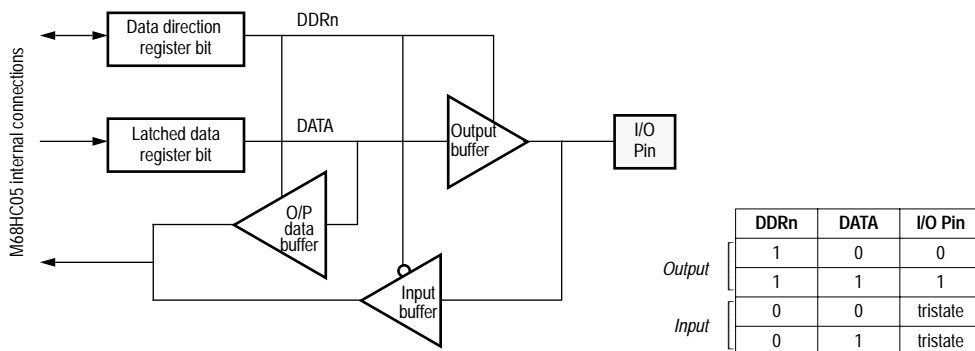

Figure 4-1 Standard I/O port structure

Table 4-1 shows the effect of reading from or writing to an I/O pin in various circumstances. Note that the read/write signal shown is internal and not available to the user.

Table 4-1 I/O pin states

R/W	DDRn	Action of MCU write to/read of data bit
0	0	The I/O pin is in input mode. Data is written into the output data latch.
0	1	Data is written into the output data latch, and output to the I/O pin.
1	0	The state of the I/O pin is read.
1	1	The I/O pin is in output mode. The output data latch is read.

4.2 Ports A and B

These ports are standard M68HC05 bidirectional I/O ports, each comprising a data register and a data direction register.

Reset does not affect the state of the data register, but clears the data direction register, thereby returning all port pins to input mode. Writing a '1' to any DDR bit sets the corresponding port pin to output mode.

Wired-OR interrupts are provided on all pins of port B. If WOIE is enabled, any combination of high logic levels on port B pins which are programmed as inputs will trigger an external interrupt. See [Section 10.2.3.2](#).

A mask option is provided to enable resistive pull downs on all port B pins that are programmed as inputs.

4.3 Port C

In addition to the standard port functions described for ports A and B, port C pin 2 can be configured, using the ECLK bit of the EEPROM/ECLK control register, to output the CPU clock. If this is selected the corresponding DDR bit is automatically set and bit 2 of port C will always read the output data latch. The other port C pins are not affected by this feature.

A mask option is provided to enable resistive pull downs on all port C pins that are programmed as inputs.

	Address	bit 7	bit 6	bit 5	bit 4	bit 3	bit 2	bit 1	bit 0	State on reset
EEPROM/ECLK control	\$0007	0	0	0	0	ECLK	E1ERA	E1LAT	E1PGM	0000 0000

ECLK — External clock option bit

- 1 (set) — ECLK CPU clock is output on PC2.
- 0 (clear) — ECLK CPU clock is not output on PC2; port C acts as a normal I/O port.

The ECLK bit is cleared by power-on or external reset. It is not affected by the execution of a STOP or WAIT instruction.

The timing diagram of the clock output is shown in [Figure 4-2](#).

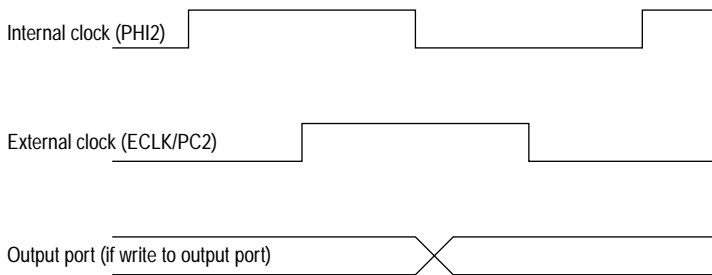

Figure 4-2 ECLK timing diagram

4.4 Port D

This 8-bit input-only port shares its pins with the A/D converter subsystem. When the A/D converter is enabled, pins PD0-PD7 read the eight analog inputs to the A/D converter. Port D can be read at any time, however, if it is read during an A/D conversion sequence noise, may be injected on the analog inputs, resulting in reduced accuracy of the A/D. Furthermore, performing a digital read of port D with levels other than V_{DD} or V_{SS} on the port D pins will result in greater power dissipation during the read cycle.

As port D is an input-only port there is no DDR associated with it. Also, at power up or external reset, the A/D converter is disabled, thus the port is configured as a standard input-only port.

Note: It is recommended that all unused input ports and I/O ports be tied to an appropriate logic level (i.e. either V_{DD} or V_{SS}).

4.5 Port registers

The following sections explain in detail the individual bits in the data and control registers associated with the ports.

4.5.1 Port data registers A and B (PORTA and PORTB)

	Address	bit 7	bit 6	bit 5	bit 4	bit 3	bit 2	bit 1	bit 0	State on reset
Port A data (PORTA)	\$0000									Undefined
Port B data (PORTB)	\$0001									Undefined

Each bit can be configured as input or output via the corresponding data direction bit in the port data direction register (DDRx).

The state of the port data registers following reset is not defined.

4.5.2 Port data register C (PORTC)

	Address	bit 7	bit 6	bit 5	bit 4	bit 3	bit 2	bit 1	bit 0	State on reset
Port C data (PORTC)	\$0002						PC2/ ECLK			Undefined

Each bit can be configured as input or output via the corresponding data direction bit in the port data direction register (DDRx).

In addition, bit 2 of port C is used to output the CPU clock if the ECLK bit in the EEPROM CTL/ECLK register is set (see [Section 4.3](#)).

The state of the port data registers following reset is not defined.

4.5.3 Port data register D (PORTD)

	Address	bit 7	bit 6	bit 5	bit 4	bit 3	bit 2	bit 1	bit 0	State on reset
Port D data (PORTD)	\$0003	PD7	PD6	PD5	PD4	PD3	PD2	PD1	PD0	Undefined

All the port D bits are input-only and are shared with the A/D converter. The function of each bit is determined by the ADON bit in the A/D status/control register.

The state of the port data registers following reset is not defined.

4.5.4 A/D status/control register

	Address	bit 7	bit 6	bit 5	bit 4	bit 3	bit 2	bit 1	bit 0	State on reset
A/D status/control	\$0009	COCO	ADRC	ADON	0	CH3	CH2	CH1	CH0	0000 0000

ADON — A/D converter on

- 1 (set) — A/D converter is switched on; all port D pins act as analog inputs for the A/D converter.
- 0 (clear) — A/D converter is switched off; all port D pins act as input only pins.

Reset clears the ADON bit, thus configuring port D as an input only port.

4.5.5 Data direction registers (DDRA, DDRB and DDRC)

	Address	bit 7	bit 6	bit 5	bit 4	bit 3	bit 2	bit 1	bit 0	State on reset
Port A data direction (DDRA)	\$0004									0000 0000
Port B data direction (DDRB)	\$0005									0000 0000
Port C data direction (DDRC)	\$0006									0000 0000

Writing a '1' to any bit configures the corresponding port pin as an output; conversely, writing any bit to '0' configures the corresponding port pin as an input.

Reset clears these registers, thus configuring all ports as inputs.

4.6 Other port considerations

All output ports can emulate 'open-drain' outputs. This is achieved by writing a zero to the relevant output port latch. By toggling the corresponding data direction bit, the port pin will either be an output zero or tri-state (an input). This is shown diagrammatically in [Figure 4-3](#).

When using a port pin as an 'open-drain' output, certain precautions must be taken in the user software. If a read-modify-write instruction is used on a port where the 'open-drain' is assigned and the pin at this time is programmed as an input, it will read it as a 'one'. The read-modify-write instruction will then write this 'one' into the output data latch on the next cycle. This would cause the 'open-drain' pin not to output a 'zero' when desired.

Note: 'Open-drain' outputs should not be pulled above V_{DD} .

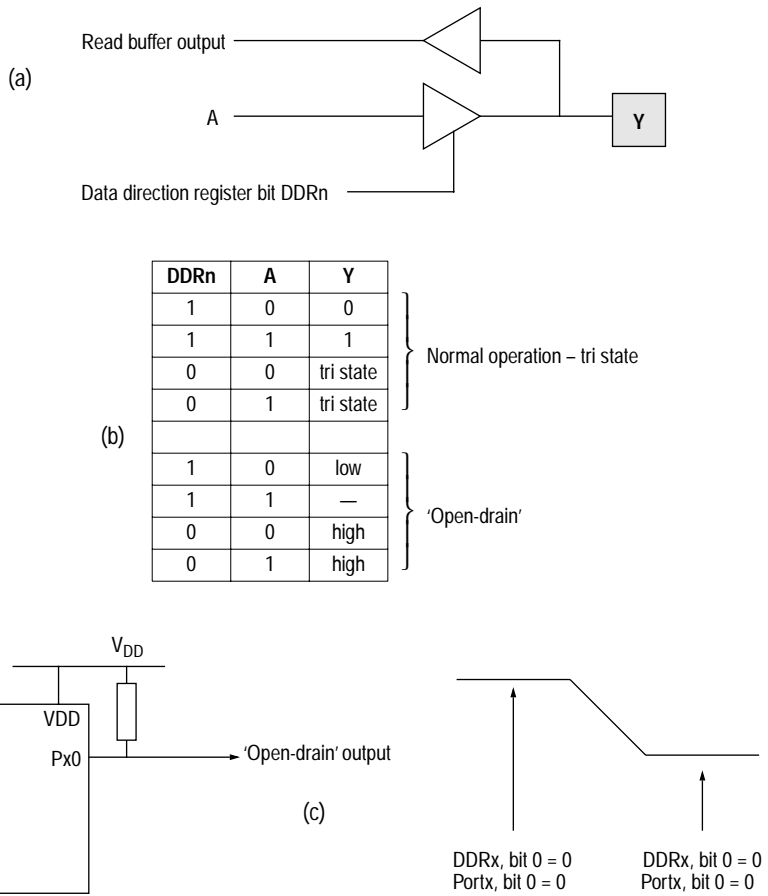

Figure 4-3 Port logic levels

THIS PAGE LEFT BLANK INTENTIONALLY

5

MOTOROLA CAN MODULE (MCAN)

5

The MCAN includes all hardware modules necessary to implement the CAN transfer layer, which represents the kernel of the CAN bus protocol as defined by BOSCH GmbH, the originators of the CAN specification. For full details of the CAN protocol please refer to the published specifications.

Up to the message level, the MCAN is totally compatible with the full CAN implementation. Functional differences are related to the object layer only. Whereas a full CAN controller provides dedicated hardware for handling a set of messages, the MCAN is restricted to receiving and/or transmitting messages on a message by message basis.

The MCAN will never initiate an overload frame. If the MCAN starts to receive a valid message (one that passes the acceptance filter) and there is no receive buffer available for it then the overrun flag in the CPU status register will be set. The MCAN will respond to overload frames generated by other CAN nodes, as required by the CAN protocol. A summary of all the MCAN frame formats is given in [Figure 5-2](#) for reference. A diagram of the major blocks of the MCAN is shown in [Figure 5-1](#).

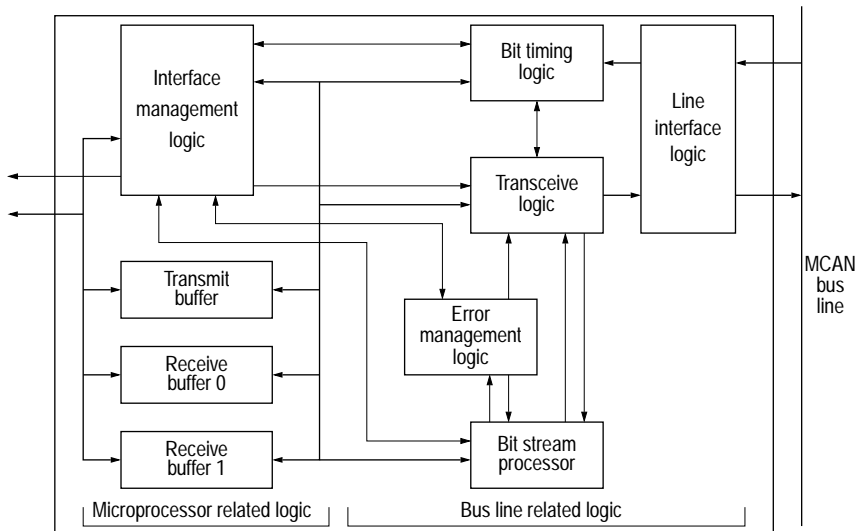

Figure 5-1 MCAN block diagram

Figure 5-2 MCAN frame formats

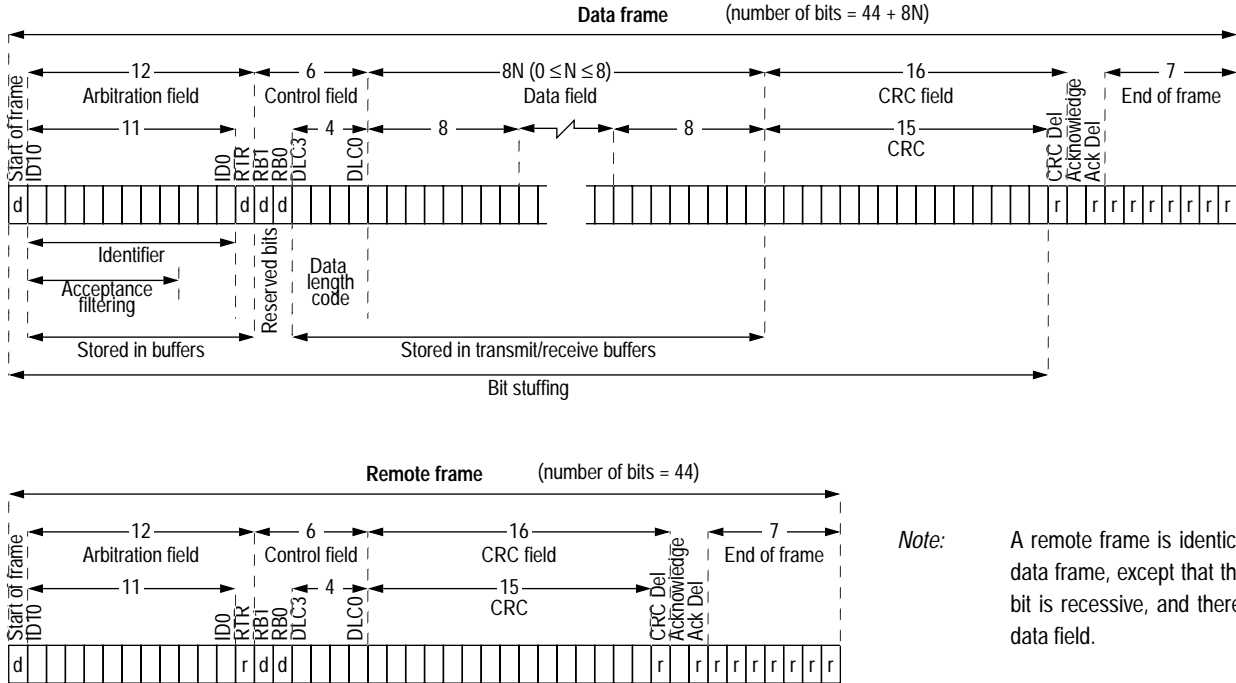
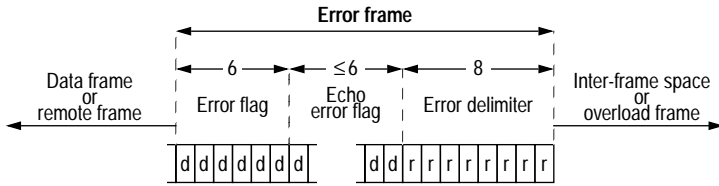
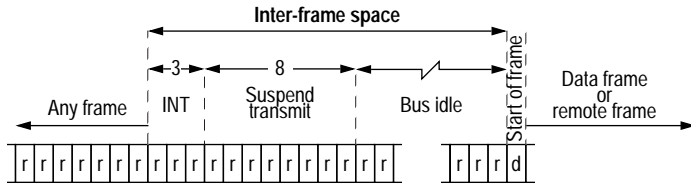

Figure 5-2 MCAN frame formats (Continued)



Note: An error frame can start anywhere in the middle of a frame.



Note: INT = Intermission
Suspend transmission is only for error passive nodes.

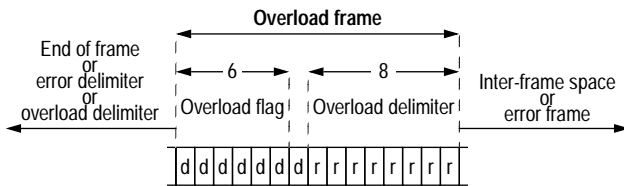

Note: An overload frame can only start at the end of a frame.
Maximum echo of overload flag is one bit.

5.1 TBF – Transmit buffer

The transmit buffer is an interface between the CPU and the bit stream processor (BSP) and is able to store a complete message. The buffer is written by the CPU and read by the BSP. The CPU may access this buffer whenever transmit buffer access is set to released. On requesting a transmission (by setting transmission request in the MCAN command register to present) transmit buffer access is set to locked, giving the BSP exclusive access to this buffer. The transmit buffer is released after the message transfer has been completed or aborted.

The TBF is 10 bytes long and holds the identifier (1 byte), the control field (1 byte) and the data field (maximum length 8 bytes). The buffer is implemented as a single-ported RAM, with mutually exclusive access by the CPU and the BSP.

5.2 RBF – Receive buffer

The receive buffer is an interface between the BSP and the CPU and stores a message received from the bus line. Once filled by the BSP and allocated to the CPU (by the IML), the receive buffer cannot be used to store subsequent received messages until the CPU has acknowledged the reading of the buffer's contents. Thus, unless the CPU releases a receive buffer within a protocol defined time frame, future messages to be received may be lost.

To reduce the requirements on the CPU, two receive buffers (RBF0 and RBF1) are implemented. While one receive buffer is allocated to the CPU, the BSP may write to the other buffer. RBF0 and RBF1 are each 10 bytes long and hold the identifier (1 byte), the control field (1 byte) and the data field (maximum length 8 bytes). The buffers are implemented as single-ported RAMs with mutually exclusive access from the CPU and the BSP. The BSP signals the MCU to read the receive buffer only when the message being received has an identifier that passes the acceptance filter. Note that a message being transmitted will be automatically written to the receive buffer if the identifier passes the acceptance filter. This is because it cannot be known, until after the first byte has been stored, whether or not the transmitting node will lose arbitration to another node.

5.3 Interface to the MC68HC05X16 CPU

The MCAN handles all the communication transactions flowing across the serial bus. For example, the CPU merely places a message to be transmitted into the transmit buffer and sets the TR bit. The MCAN will begin transmitting the message when it has determined that the bus is idle. In the event of a transmission error, the MCAN will initiate a repeated transmission automatically.

In a similar manner, the CPU module is notified that a message has been received only if it was error free. If any error occurs, the MCAN signals the error within the CAN protocol without CPU intervention.

The MCAN within the MC68HC05X16 is controlled using a block of 30 registers. This comprises 10 control registers, 10 Transmit buffer registers and 10 receive buffer registers. These registers are memory mapped between \$20 and \$3D (see Figure 5-3).

Note: There is an offset of \$20 between the MC68HC05X16 addresses and the MCAN internal addresses, i.e. MCAN addresses \$00 to \$1D, as defined in the BOSCH CAN specification, are mapped to MC68HC05X16 addresses \$20 to \$3D.

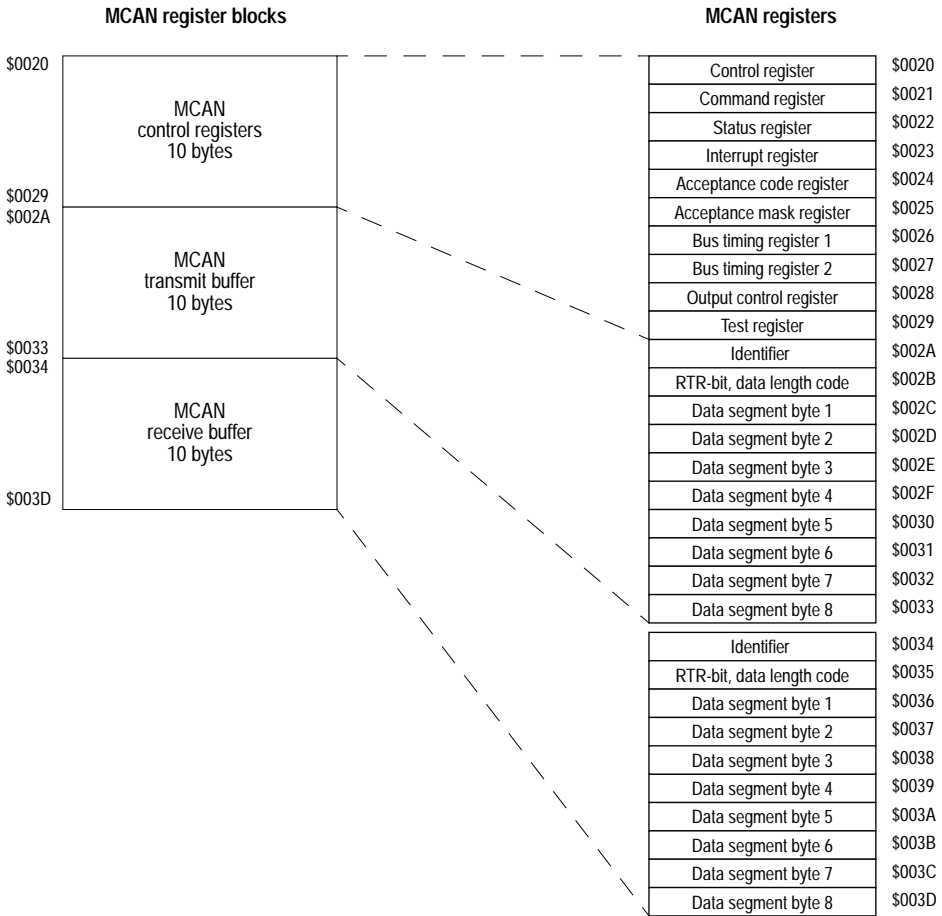

Figure 5-3 MCAN module memory map

5.3.1 MCAN control register (CCNTRL)

This register may be read or written to by the MCU; only the RR bit is affected by the MCAN.

	Address	bit 7	bit 6	bit 5	bit 4	bit 3	bit 2	bit 1	bit 0	Reset condition	State on reset
MCAN control (CCNTRL)	\$0020	MODE	SPD		OIE	EIE	TIE	RIE	RR	External reset	0u - u uu1
				RR bit set						0u - u uu1	

MODE — Undefined mode

This bit must never be set by the CPU as this would result in the transmit and receive buffers being mapped out of memory. The bit is cleared on reset, and should be left in this state for normal operation.

SPD — Speed mode

- 1 (set) – Slow – Bus line transitions from both ‘recessive’ to ‘dominant’ and from ‘dominant’ to ‘recessive’ will be used for resynchronization.
- 0 (clear) – Fast – Only transitions from ‘recessive’ to ‘dominant’ will be used for resynchronization.

OIE — Overrun interrupt enable

- 1 (set) – Enabled – The CPU will get an interrupt request whenever the Overrun Status bit gets set.
- 0 (clear) – Disabled – The CPU will get no overrun interrupt request.

EIE — Error interrupt enable

- 1 (set) – Enabled – The CPU will get an interrupt request whenever the error status or bus status bits in the CSTAT register change.
- 0 (clear) – Disabled – The CPU will get no error interrupt request.

TIE — Transmit interrupt enable

- 1 (set) – Enabled – The CPU will get an interrupt request whenever a message has been successfully transmitted, or when the transmit buffer is accessible again following an ABORT command.
- 0 (clear) – Disabled – The CPU will get no transmit interrupt request.

RIE — Receive interrupt enable

- 1 (set) – Enabled – The CPU will get an interrupt request whenever a message has been received free of errors.
- 0 (clear) – Disabled – The CPU will get no receive interrupt request.

RR — Reset request

When the MCAN detects that RR has been set it aborts the current transmission or reception of a message and enters the reset state. A reset request may be generated by either an external reset or by the CPU or by the MCAN. The RR bit can be cleared only by the CPU. After the RR bit has been cleared, the MCAN will start normal operation in one of two ways. If RR was generated by an external reset or by the CPU, then the MCAN starts normal operation after the first occurrence of 11 recessive bits. If, however, the RR was generated by the MCAN due to the BS bit being set (see [Section 5.3.3](#)) the MCAN waits for 128 occurrences of 11 recessive bits before starting normal operation.

A reset request should not be generated by the CPU during a message transmission. Ensure that a message is not being transmitted as follows:

if TCS in CSTAT is clear – set AT in CCOM (use STA or STX), read CSTAT.

if TS in CSTAT is set – wait until TS is clear.

Note that a CPU-generated reset request does not change the values in the transmit and receive error counters.

- 1 (set) – Present – MCAN will be reset.
- 0 (clear) – Absent – MCAN will operate normally.

Note: The following registers may only be accessed when reset request = present: CACC, CACM, CBT0, CBT1, and COCNTRL.

5.3.2 MCAN command register (CCOM)

This is a write only register; a read of this location will always return the value \$FF.

This register may be written only when the RR bit in CCNTRL is clear.

Do not use read-modify-write instructions on this register (e.g. BSET, BCLR).

	Address	bit 7	bit 6	bit 5	bit 4	bit 3	bit 2	bit 1	bit 0	Reset condition	State on reset
MCAN command (CCOM)	\$0020	RX0	RX1	COMPSEL	SLEEP	COS	RRB	AT	TR	External reset	00u0 0000
										RR bit set	00u0 0000

RX0 — Receive pin 0 (passive) (Refer to Figure 5-6)

- 1 (set) – VDD/2 will be connected to the input comparator. The RX0 pin is disconnected.
- 0 (clear) – The RX0 pin will be connected to the input comparator. VDD/2 is disconnected.

RX1 — Receive pin 1 (passive) (Refer to Figure 5-6)

- 1 (set) – VDD/2 will be connected to the input comparator. The RX1 pin is disconnected.
- 0 (clear) – The RX1 pin will be connected to the input comparator. VDD/2 is disconnected.

Note: If both RX0 and RX1 are set, or both are clear, then neither of the RX pins will be disconnected.

COMPSEL — Comparator selector

- 1 (set) – RX0 and RX1 will be compared with VDD/2 during sleep mode (see Figure 5-6).
- 0 (clear) – RX0 will be compared with RX1 during sleep mode.

SLEEP — Go to sleep

- 1 (set) – Sleep – The MCAN will go into sleep mode, as long as there are no interrupts pending and there is no activity on the bus. Otherwise the MCAN will issue a wake-up interrupt.
- 0 (clear) – Wake-up – The MCAN will function normally. If SLEEP is cleared by the CPU then the MCAN will waken up, but will not issue a wake-up interrupt.

Note: If SLEEP is set during the reception or transmission of a message, the MCAN will generate an immediate wake-up interrupt. (This allows for a more orthogonal software implementation on the CPU.) This will have no effect on the transfer layer, i.e. no message will be lost or corrupted.

The CAF flag in the EEPROM control register indicates whether or not sleep mode was entered successfully.

A node that was sleeping and has been awakened by bus activity will not be able to receive any messages until its oscillator has started and it has found a valid end of

frame sequence (11 recessive bits). The designer must take this into consideration when planning to use the sleep command.

COS — Clear overrun status

- 1 (set) – This clears the read-only data overrun status bit in the CSTAT register (see [Section 5.3.3](#)). It may be written at the same time as RRB.
- 0 (clear) – No action.

RRB — Release receive buffer

When set this releases the receive buffer currently attached to the CPU, allowing the buffer to be reused by the MCAN. This may result in another message being received, which could cause another receive interrupt request (if RIE is set). This bit is cleared automatically when a message is received, i.e. when the RS bit (see [Section 5.3.3](#)) becomes set.

- 1 (set) – Released – receive buffer is available to the MCAN.
- 0 (clear) – No action.

AT — Abort transmission

When this bit is set a pending transmission will be cancelled if it is not already in progress, allowing the transmit buffer to be loaded with a new (higher priority) message when the buffer is released. If the CPU tries to write to the buffer when it is locked, the information will be lost without being signalled. The status register can be checked to see if transmission was aborted or is still in progress.

- 1 (set) – Present – Abort transmission of any pending messages.
- 0 (clear) – No action.

TR — Transmission request

- 1 (set) – Present – Depending on the transmission buffer's content, a data frame or a remote frame will be transmitted.
- 0 (clear) – No action. This will not cancel a previously requested transmission; the abort transmission command must be used to do this.

5.3.3 MCAN status register (CSTAT)

This is a read only register; only the MCAN can change its contents.

MCAN status (CSTAT)	Address	bit 7	bit 6	bit 5	bit 4	bit 3	bit 2	bit 1	bit 0	Reset condition	State on reset
	\$0022	BS	ES	TS	RS	TCS	TBA	DO	RBS	External reset	0000 1100
									RR bit set	uu00 1100	

BS — Bus status

This bit is set (off-bus) by the MCAN when the transmit error counter reaches 256. The MCAN will then set RR and will remain off-bus until the CPU clears RR again. At this point the MCAN will wait for 128 successive occurrences of a sequence of 11 recessive bits before clearing BS and resetting the read and write error counters. While off-bus the MCAN does not take part in bus activities.

- 1 (set) – Off-bus – The MCAN is not participating in bus activities.
- 0 (clear) – On-bus – The MCAN is operating normally.

ES — Error status

- 1 (set) – Error – Either the read or the write error counter has reached the CPU warning limit of 96.
- 0 (clear) – Neither of the error counters has reached 96.

TS — Transmit status

- 1 (set) – Transmit – The MCAN has started to transmit a message.
- 0 (clear) – Idle – If the receive status bit is also clear then the MCAN is idle; otherwise it is in receive mode.

RS — Receive status

- 1 (set) – Receive – The MCAN entered receive mode from idle, or by losing arbitration during transmission.
- 0 (clear) – Idle – If the transmit status bit is also clear then the MCAN is idle; otherwise it is in transmit mode.

5

TCS — Transmission complete status

This bit is cleared by the MCAN when TR becomes set. When TCS is set it indicates that the last requested transmission was successfully completed. If, after TCS is cleared, but before transmission begins, an abort transmission command is issued then the transmit buffer will be released and TCS will remain clear. TCS will then only be set after a further transmission is both requested and successfully completed.

- 1 (set) – Complete – Last requested transmission successfully completed.
- 0 (clear) – Incomplete – Last requested transmission not complete.

TBA — Transmit buffer access

When clear, the transmit buffer is locked and cannot be accessed by the CPU. This indicates that either a message is being transmitted, or is awaiting transmission. If the CPU writes to the transmit buffer while it is locked, then the bytes will be lost without this being signalled.

- 1 (set) – Released – The transmit buffer may be written to by the CPU.
- 0 (clear) – Locked – The CPU cannot access the transmit buffer.

DO — Data overrun

This bit is set when both receive buffers are full and there is a further message to be stored. In this case the new message is dropped, but the internal logic maintains the correct protocol. The MCAN does not receive the message, but no warning is sent to the transmitting node. The MCAN clears DO when the CPU sets the COS bit in the CCOM register.

Note that data overrun can also be caused by a transmission, since the MCAN will temporarily store an outgoing frame in a receive buffer in case arbitration is lost during transmission.

- 1 (set) – Overrun – Both receive buffers were full and there was another message to be stored.
- 0 (clear) – Normal operation.

RBS — Receive buffer status

This bit is set by the MCAN when a new message is available. When clear this indicates that no message has become available since the last RRB command. The bit is cleared when RRB is set. However, if the second receive buffer already contains a message, then control of that buffer is given to the CPU and RBS is immediately set again. The first receive buffer is then available for the next incoming message from the MCAN.

- 1 (set) – Full – A new message is available for the CPU to read.
- 0 (clear) – Empty – No new message is available.

5.3.4 MCAN interrupt register (CINT)

All bits of this register are read only; all are cleared by a read of the register.

This register must be read in the interrupt handling routine in order to enable further interrupts.

MCAN interrupt (CINT)	Address	bit 7	bit 6	bit 5	bit 4	bit 3	bit 2	bit 1	bit 0	Reset condition	State on reset
	\$0023				WIF	OIF	EIF	TIF	RIF	External reset	--- 0 0000
									RR bit set	--- u 0u00	

5

WIF — Wake-up interrupt flag

If the MCAN detects bus activity whilst it is asleep, it clears the SLEEP bit in the CCOM register; the WIF bit will then be set. WIF is cleared by reading the MCAN interrupt register (CINT), or by an external reset.

- 1 (set) – MCAN has detected activity on the bus and requested wake-up.
- 0 (clear) – No wake-up interrupt has occurred.

OIF — Overrun interrupt flag

When OIE is set then this bit will be set when a data overrun condition is detected. Like all the bits in this register, OIF is cleared by reading the register, or when reset request is set.

- 1 (set) – A data overrun has been detected.
- 0 (clear) – No data overrun has occurred.

EIF — Error interrupt flag

When EIE is set then this bit will be set by a change in the error or bus status bits in the MCAN status register. Like all the bits in this register, EIF is cleared by reading the register, or by an external reset.

- 1 (set) – There has been a change in the error or bus status bits in CSTAT.
- 0 (clear) – No error interrupt has occurred.

TIF — Transmit interrupt flag

The TIF bit is set at the end of a transmission whenever both the TBA and TIE bits are set. Like all the bits in this register, TIF is cleared by reading the register, or when reset request is set.

- 1 (set) – Transmission complete, the transmit buffer is accessible.
- 0 (clear) – No transmit interrupt has occurred.

RIF — Receive interrupt flag

The RIF bit is set by the MCAN when a new message is available in the receive buffer, and the RIE bit in CCNTRL is set. At the same time RBS is set. Like all the bits in this register, RIF is cleared by reading the register, or when reset request is set.

- 1 (set) – A new message is available in the receive buffer.
- 0 (clear) – No receive interrupt has occurred.

5.3.5 MCAN acceptance code register (CACC)

On reception each message is written into the current receive buffer. The MCU is only signalled to read the message however, if it passes the criteria in the acceptance code and acceptance mask registers (accepted); otherwise, the message will be overwritten by the next message (dropped).

Note: This register can only be accessed when the reset request bit in the CCNTRL register is set.

	Address	bit 7	bit 6	bit 5	bit 4	bit 3	bit 2	bit 1	bit 0	State on reset
MCAN acceptance code (CACC)	\$0024	AC7	AC6	AC5	AC4	AC3	AC2	AC1	AC0	Undefined

AC7 – AC0 — Acceptance code bits

AC7 – AC0 comprise a user defined sequence of bits with which the 8 most significant bits of the data identifier (ID10 – ID3) are compared. The result of this comparison is then masked with the acceptance mask register. Once a message has passed the acceptance criterion the respective identifier, data length code and data are sequentially stored in a receive buffer, providing there is one free. If there is no free buffer, the data overrun condition will be signalled.

On acceptance the receive buffer status bit is set to full and the receive interrupt bit is set (provided RIE = enabled).

5.3.6 MCAN acceptance mask register (CACM)

The acceptance mask register specifies which of the corresponding bits in the acceptance code register are relevant for acceptance filtering.

Note: This register can only be accessed when the reset request bit in the CCNTRL register is set.

	Address	bit 7	bit 6	bit 5	bit 4	bit 3	bit 2	bit 1	bit 0	State on reset
MCAN acceptance mask (CACM)	\$0025	AM7	AM6	AM5	AM4	AM3	AM2	AM1	AM0	Undefined

AM0 – AM7 — Acceptance mask bits

When a particular bit in this register is clear this indicates that the corresponding bit in the acceptance code register must be the same as its identifier bit, before a match will be detected. The message will be accepted if all such bits match. When a bit is set, it indicates that the state of the corresponding bit in the acceptance code register will not affect whether or not the message is accepted.

1 (set) – Ignore corresponding acceptance code register bit.

0 (clear) – Match corresponding acceptance code register and identifier bits.

5.3.7 MCAN bus timing register 0 (CBT0)

Note: This register can only be accessed when the reset request bit in the CCNTRL register is set.

	Address	bit 7	bit 6	bit 5	bit 4	bit 3	bit 2	bit 1	bit 0	State on reset
MCAN bus timing 0 (CBT0)	\$0026	SJW1	SJW0	BRP5	BRP4	BRP3	BRP2	BRP1	BRP0	Undefined

SJW1, SJW0 — Synchronization jump width bits

The synchronization jump width defines the maximum number of system clock (t_{SCL}) cycles by which a bit may be shortened, or lengthened, to achieve resynchronization on data transitions on the bus (see [Table 5-1](#)).

Table 5-1 Synchronization jump width

SJW1	SJW0	Synchronization jump width
0	0	1 t_{SCL} cycle
0	1	2 t_{SCL} cycles
1	0	3 t_{SCL} cycles
1	1	4 t_{SCL} cycles

BRP5 – BRP0 — Baud rate prescaler bits

These bits determine the MCAN system clock cycle time (t_{SCL}), which is used to build up the individual bit timing, according to [Table 5-2](#) and the formula in [Figure 5-4](#).

Table 5-2 Baud rate prescaler

BRP5	BRP4	BRP3	BRP2	BRP1	BRP0	Prescaler value (P)
0	0	0	0	0	0	1
0	0	0	0	0	1	2
0	0	0	0	1	0	3
0	0	0	0	1	1	4
:	:	:	:	:	:	:
:	:	:	:	:	:	:
1	1	1	1	1	1	64

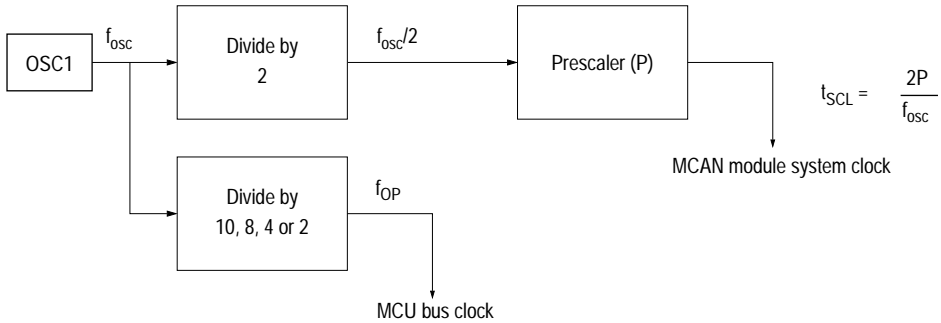

Figure 5-4 Oscillator block diagram

5.3.8 MCAN bus timing register 1 (CBT1)

This register can only be accessed when the reset request bit in the CCNTRL register is set.

Address	bit 7	bit 6	bit 5	bit 4	bit 3	bit 2	bit 1	bit 0	State on reset	
MCAN bus timing 1 (CBT1)	\$0027	SAMP	TSEG22	TSEG21	TSEG20	TSEG13	TSEG12	TSEG11	TSEG10	Undefined

SAMP — Sampling

This bit determines the number of samples of the serial bus to be taken per bit time. When set three samples per bit are taken. This sample rate gives better rejection of noise on the bus, but introduces a one bit delay to the bus sampling. For higher bit rates SAMP should be cleared, which means that only one sample will be taken per bit.

1 (set) – Three samples per bit.

0 (clear) – One sample per bit.

TSEG22 – TSEG10 — Time segment bits

Time segments within the bit time fix the number of clock cycles per bit time, and the location of the sample point.

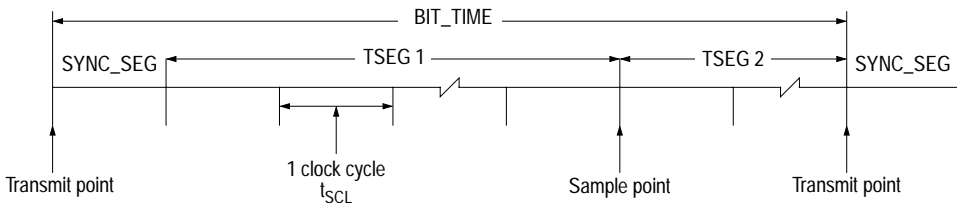

Figure 5-5 Segments within the bit time

SYNC_SEG System expects transitions to occur on the bus during this period.

Transmit point A node in transmit mode will transfer a new value to the MCAN bus at this point.

Sample point A node in receive mode will sample the bus at this point. If the three samples per bit option is selected then this point marks the position of the third sample.

Time segment 1 (TSEG1) and time segment 2 (TSEG2) are programmable as shown in [Table 5-3](#).

The bit time is determined by the oscillator frequency, the baud rate prescaler, and the number of bus clock cycles (t_{SCL}) per bit (as shown above).

Table 5-3 Time segment values

TSEG13	TSEG12	TSEG11	TSEG10	Time segment 1	TSEG22	TSEG21	TSEG20	Time segment 2
0	0	0	1	2 t_{SCL} cycles	0	0	1	2 t_{SCL} cycles
0	0	1	0	3 t_{SCL} cycles
0	0	1	1	4 t_{SCL} cycles
.	1	1	1	8 t_{SCL} cycles
.				
1	1	1	1	16 t_{SCL} cycles				

Calculation of the bit time

$$BIT_TIME = SYNC_SEG + TSEG1 + TSEG2$$

Note: TSEG2 must be at least 2 t_{SCL} , i.e. the configuration bits must not be 000. (If three samples per bit mode is selected then TSEG2 must be at least 3 t_{SCL} .)

TSEG1 must be at least as long as TSEG2.

The synchronization jump width (SJW) may not exceed TSEG2, and must be at least t_{SCL} shorter than TSEG1 to allow for physical propagation delays.

i.e. in terms of t_{SCL} :

$$SYNC_SEG = 1$$

$$TSEG1 \geq SJW + 1$$

$$TSEG1 \geq TSEG2$$

$$TSEG2 \geq SJW$$

and $TSEG2 \geq 2$ (SAMP = 0)

or $TSEG2 \geq 3$ (SAMP = 1)

These boundary conditions result in minimum bit times of 5 t_{SCL} , for one sample, and 7 t_{SCL} , for three samples per bit.

5.3.9 MCAN output control register (COCNTRL)

This register allows the setup of different output driver configurations under software control. The user may select active pull-up, pull-down, float or push-pull output.

Note: This register can only be accessed when the reset request bit in the CCNTRL register is set.

	Address	bit 7	bit 6	bit 5	bit 4	bit 3	bit 2	bit 1	bit 0	State on reset
MCAN output control (COCNTRL)	\$0028	OCTP1	OCTN1	OPOL1	OCTP0	OCTN0	OPOL0	OCM1	OCM0	Undefined

OCM1 and OCM0 — Output control mode bits

The values of these two bits determine the output mode, as shown in [Table 5-4](#).

Table 5-4 Output control modes

OCM1	OCM0	Function
0	0	Biphase mode
0	1	Not used
1	0	Normal mode 1 Bit stream transmitted on both TX0 and TX1
1	1	Normal mode 2 TX0 - bit sequence TX1 - bus clock (t_{xclk})

Note: The transmit clock (t_{xclk}) is used to indicate the end of the bit time and will be high during the SYNC_SEG.

For all the following modes of operation, a dominant bit is internally coded as a zero, a recessive as a one. The other output control bits are used to determine the actual voltage levels transmitted to the MCAN bus for dominant and recessive bits.

Biphase mode

If the CAN modules are isolated from the bus lines by a transformer then the bit stream has to be coded so that there is no resulting dc component. There is a flip-flop within the MCAN that keeps the last dominant configuration; its direct output goes to TX0 and its complement to TX1. The flip-flop is toggled for each dominant bit; dominant bits are thus sent alternately on TX0 and TX1; i.e. the first dominant bit is sent on TX0, the second on TX1, the third on TX0 and so on. During recessive bits, all output drivers are deactivated (i.e. high impedance).

Normal mode 1

In contrast to biphase mode the bit representation is time invariant and not toggled.

Normal mode 2

For the TX0 pin this is the same as normal mode 1, however the data stream to TX1 is replaced by the transmit clock. The rising edge of the transmit clock marks the beginning of a bit time. The clock pulse will be t_{SCL} long.

Other output control bits

The other six bits in this register control the output driver configurations, to determine the format of the output signal for a given data value (see [Figure 5-6](#)).

OCTP0/1 – These two bits control whether the P-type output control transistors are enabled.

OCTN0/1 – These two bits control whether the N-type output control transistors are enabled.

OCPOL0/1 – These two bits determine the driver output polarity for each of the MCAN bus lines (TX0, TX1).

TP0/1 and TN0/1 – These are the resulting states of the output transistors.

TD – This is the internal value of the data bit to be transferred across the MCAN bus. (A zero corresponds to a dominant bit, a one to a recessive.)

The actions of these bits in the output control register are as shown in [Table 5-5](#).

Table 5-5 MCAN driver output levels

Mode	TD	OCPOLi	OCTPi	OCTNi	TPi	TNi	TXi output level
Float	0	0	0	0	Off	Off	Float
	1	0	0	0	Off	Off	Float
	0	1	0	0	Off	Off	Float
	1	1	0	0	Off	Off	Float
Pull-down	0	0	0	1	Off	On	Low
	1	0	0	1	Off	Off	Float
	0	1	0	1	Off	Off	Float
	1	1	0	1	Off	On	Low
Pull-up	0	0	1	0	Off	Off	Float
	1	0	1	0	On	Off	High
	0	1	1	0	On	Off	High
	1	1	1	0	Off	Off	Float
Push-pull	0	0	1	1	Off	On	Low
	1	0	1	1	On	Off	High
	0	1	1	1	On	Off	High
	1	1	1	1	Off	On	Low

5.3.10 Transmit buffer identifier register (TBI)

	Address	bit 7	bit 6	bit 5	bit 4	bit 3	bit 2	bit 1	bit 0	State on reset
Transmit buffer identifier (TBI)	\$002A	ID10	ID9	ID8	ID7	ID6	ID5	ID4	ID3	Undefined

ID10 – ID3 — Identifier bits

The identifier consists of 11 bits (ID10 – ID0). ID10 is the most significant bit and is transmitted first on the bus during the arbitration procedure. The priority of an identifier is defined to be highest for the smallest binary number. The three least significant bits are contained in the TRTDL register. The seven most significant bits must not all be recessive.

5

5.3.11 Remote transmission request and data length code register (TRTDL)

	Address	bit 7	bit 6	bit 5	bit 4	bit 3	bit 2	bit 1	bit 0	State on reset
RTR and data length code (TRTDL)	\$002B	ID2	ID1	ID0	RTR	DLC3	DLC2	DLC1	DLC0	Undefined

ID2 – ID0 — Identifier bits

These bits contain the least significant bits of the transmit buffer identifier.

RTR — Remote transmission request

- 1 (set) – A remote frame will be transmitted.
- 0 (clear) – A data frame will be transmitted.

DLC3 – DLC0 — Data length code bits.

The data length code contains the number of bytes (data byte count) of the respective message. At transmission of a remote frame, the data length code is ignored, forcing the number of bytes to be 0. The data byte count ranges from 0 to 8 for a data frame. [Table 5-6](#) shows the effect of setting the DLC bits.

Table 5-6 Data length codes

Data length code				Data byte count
DLC3	DLC2	DLC1	DLC0	
0	0	0	0	0
0	0	0	1	1
0	0	1	0	2
0	0	1	1	3
0	1	0	0	4
0	1	0	1	5
0	1	1	0	6
0	1	1	1	7
1	0	0	0	8

5.3.12 Transmit data segment registers (TDS) 1 – 8

Address	bit 7	bit 6	bit 5	bit 4	bit 3	bit 2	bit 1	bit 0	State on reset
Transmit data segment (TDS) \$002C – \$0033	DB7	DB6	DB5	DB4	DB3	DB2	DB1	DB0	Undefined

DB7 – DB0 — data bits

These data bits in the eight data segment registers make up the bytes of data to be transmitted. The number of bytes to be transmitted is determined by the data length code.

5.3.13 Receive buffer identifier register (RBI)

The layout of this register is identical to the TBI register (see [Section 5.3.10](#)).

Address	bit 7	bit 6	bit 5	bit 4	bit 3	bit 2	bit 1	bit 0	State on reset
Receive buffer identifier (RBI)	ID10	ID9	ID8	ID7	ID6	ID5	ID4	ID3	Undefined

(Note that there are actually two receive buffer register sets, but switching between them is handled internally by the MCAN.)

5.3.14 Remote transmission request and data length code register (RRTDL)

The layout of this register is identical to the TRTDL register (see [Section 5.3.11](#)).

	Address	bit 7	bit 6	bit 5	bit 4	bit 3	bit 2	bit 1	bit 0	State on reset
RTR and data length code (RRTDL)	\$0035	ID2	ID1	ID0	RTR	DLC3	DLC2	DLC1	DLC0	Undefined

5

5.3.15 Receive data segment registers (RDS) 1 – 8

The layout of these registers is identical to the TDSx registers (see [Section 5.3.12](#)).

	Address	bit 7	bit 6	bit 5	bit 4	bit 3	bit 2	bit 1	bit 0	State on reset
Receive data segment (RDS)	\$0036 – \$003D	DB7	DB6	DB5	DB4	DB3	DB2	DB1	DB0	Undefined

(Note that there are actually two receive buffer register sets, but switching between them is handled internally by the MCAN.)

5.4 Interface to the MCAN bus

Physically, the MCAN bus may be composed of two wires. The bus can take on one of two values: dominant or recessive. During simultaneous transmission of dominant and recessive bits by two or more CAN modules the resulting bus value will be dominant. (For example, with a wired-AND implementation of the bus, the dominant level would correspond to a logic 0, and the recessive level to a logic 1.)

The two wires of the MCAN bus are designated CANH and CANL. The voltage levels appearing on these lines are designated V_{CANH} and V_{CANL} . A simple termination network is required for each wire. [Figure 5-6](#) shows the physical interface circuitry within the MCAN module, and its connection to the MCAN bus with a typical low speed (<125 kbaud) hardware interface. (Note that the suggested values shown in the diagram are subject to change in the future.)

For the voltage and resistor values shown in [Figure 5-6](#) the voltages on the MCAN bus are:

- Recessive level: $V_{CANH} = 3.25\text{ V}$ $V_{CANL} = 1.75\text{ V}$
- Dominant level: $V_{CANH} = 1.00\text{ V}$ $V_{CANL} = 4.00\text{ V}$

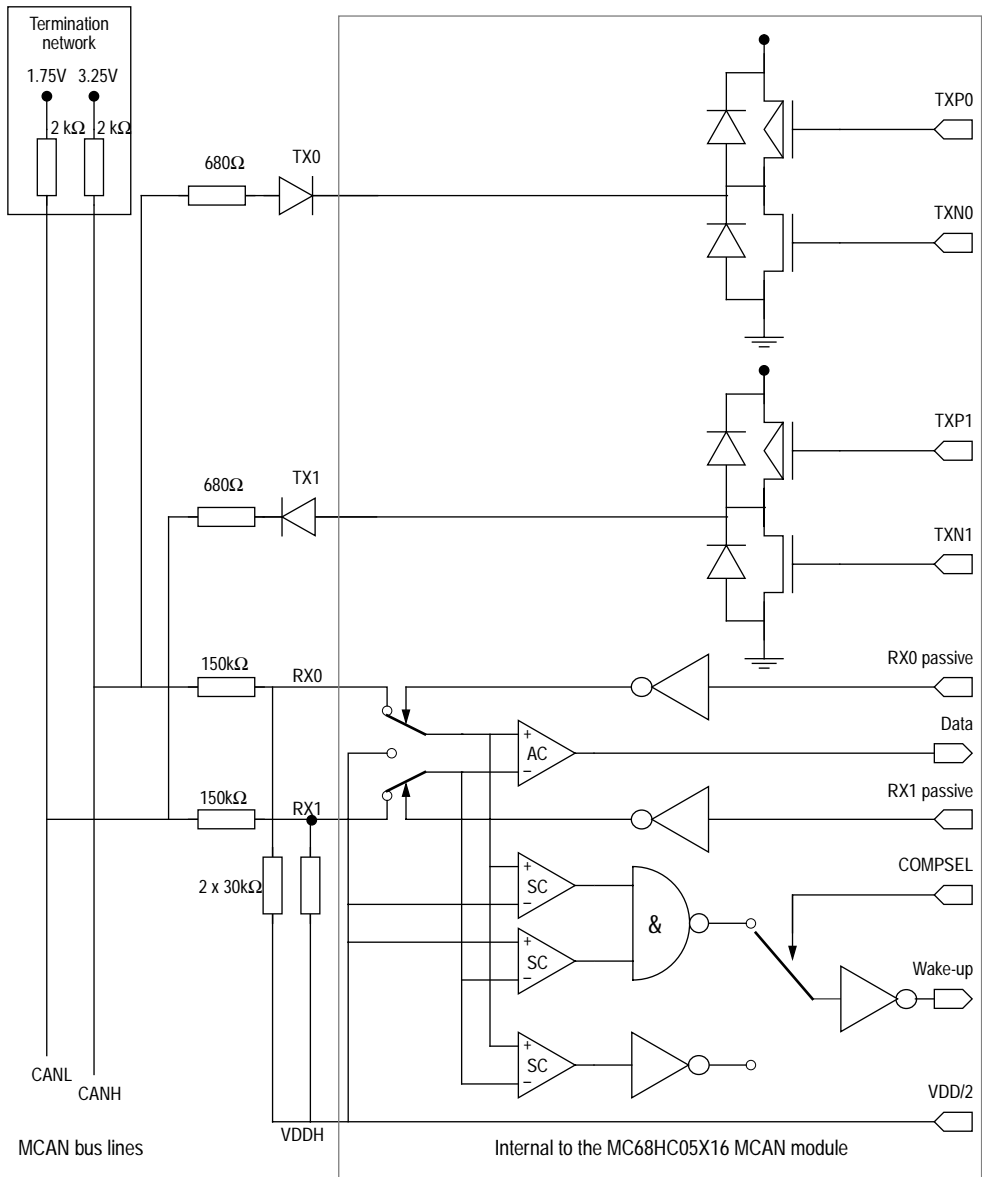

Figure 5-6 A typical physical interface between the MCAN and the MCAN bus lines

If several CAN modules are driving a dominant level on the bus at the same time then the values for V_{CANH} and V_{CANL} can go to 0.3 and 4.7 volts respectively. The residual 0.3 V is due to the voltage drop across the diodes and driver transistors in the transmission circuit.

The receiver part of the network uses two identical voltage divider networks, with a divide ratio of 6:1 (resistor values of 150k Ω and 30k Ω) referenced to $V_{DD}/2$. This increases the common mode range of the input comparator on the physical bus lines. If the common mode range of the comparator at its inputs is 1.5 to 3.5 volts then, for $V_{DD} = 5.0$ V, the common mode range will be increased to -3.5 to $+8.5$ volts on the bus lines.

5.4.1 Single wire operation

In the event of a bus fault occurring, limited operation of the MCAN bus may still be possible, depending on the nature of the fault. If the fault is due to a short circuit between the two bus lines or between one of the lines and ground, battery voltage or some other potential, it is possible to identify (using a special software procedure) the line on which the fault exists and to switch the corresponding comparator input from the faulty line to the $V_{DD}/2$ reference supply. At the same time the driver transistors to the faulty line should also be switched off. This will allow communication to continue on the bus. One result of this mode of one wire transmission is a significant reduction in the common mode range of the input comparator.

Switching to one wire operation is achieved using the control bits RX0-passive and RX1-passive in the MCAN command register, located at address \$21. Setting either of these bits will result in the corresponding input being disconnected from the bus and connected to $V_{DD}/2$.

5.5 Sleep mode

If the SLEEP bit in the MCAN command register is set by the processor the MCAN will go to sleep, unless it is active. If there is activity on the MCAN bus lines, or there is an interrupt pending, the MCAN is deemed to be active and will not go to sleep; a wake-up interrupt will be generated by the MCAN in these circumstances. The SLEEP bit may also be cleared by the processor, in which case no wake-up interrupt will be generated. Note that this bit is write-only by the CPU, and it is not possible therefore to check whether sleep mode has been entered by reading it. However, the CAF bit in the EEPROM control register is set when the MCAN is asleep, and cleared when it is woken up (see [Section 3.5.1](#)).

In order to minimize power consumption, the active comparator is switched off and the sleep comparator circuitry is used to detect activity on the bus. When in sleep mode the MCAN stops its own clocks, leaving the MCU in normal run mode. (Similarly a STOP instruction will stop the processor clocks, leaving the MCAN in run mode.) The on-chip oscillator will stop only if the MCAN is in sleep mode and the MCU executes a STOP instruction. There is a time delay between the STOP instruction being executed and the oscillator stopping. During this time it is possible that the MCAN will come out of sleep mode, and hence prevent the oscillator from stopping.

When a dominant level is detected on the MCAN bus, the MCAN is woken up and a wake-up interrupt is generated.

Under normal operation the two MCAN bus lines are forced to complementary logic levels. The level of one of the two wires can be disregarded and replaced by $V_{DD}/2$ by setting one of the control bits, RX0 or RX1.

5.5.1 Sleep comparator reference

When the COMPSEL bit in the MCAN command register (\$21) is cleared the sleep comparator inputs are the same as for the active comparator. However, when the COMPSEL bit is set each input is compared with $V_{DD}/2$ (V_{DDH} – see [Figure 5-6](#)) to detect a dominant level. For further details of the active comparator, the sleep comparator and V_{DDH} , refer to [Section 12](#).

THIS PAGE LEFT BLANK INTENTIONALLY

6

PROGRAMMABLE TIMER

The programmable timer on the MC68HC05X32 consists of a 16-bit read-only free-running counter, with a fixed divide-by-four prescaler, plus the input capture/output compare circuitry. The timer can be used for many purposes including measuring pulse length of two input signals and generating two output signals. Pulse lengths for both input and output signals can vary from several microseconds to many seconds. In addition, it works in conjunction with the pulse width modulation (PWM) system to execute two 8-bit D/A PLM (pulse length modulation) conversions, with a choice of two repetition rates. The timer is also capable of generating periodic interrupts or indicating passage of an arbitrary multiple of four CPU cycles. A block diagram is shown in [Figure 6-1](#), and timing diagrams are shown in [Figure 6-2](#), [Figure 6-3](#), [Figure 6-4](#) and [Figure 6-5](#).

The timer has a 16-bit architecture, hence each specific functional segment is represented by two 8-bit registers (except the PLMA and PLMB which use one 8-bit register for each). These registers contain the high and low byte of that functional segment. Accessing the low byte of a specific timer function allows full control of that function; however, an access of the high byte inhibits that specific timer function until the low byte is also accessed.

The 16-bit programmable timer is monitored and controlled by a group of sixteen registers, full details of which are contained in this section.

Note: A problem may arise if an interrupt occurs in the time between the high and low bytes being accessed. To prevent this, the I-bit in the condition code register (CCR) should be set while manipulating both the high and low byte register of a specific timer function, ensuring that an interrupt does not occur.

6.1 Counter

The key element in the programmable timer is a 16-bit, free-running counter or counter register, preceded by a prescaler that divides the internal processor clock by four. The prescaler gives the timer a resolution of $2\mu\text{s}$ if the internal bus clock is 2 MHz. The counter is incremented during the low portion of the internal bus clock. Software can read the counter at any time without affecting its value.

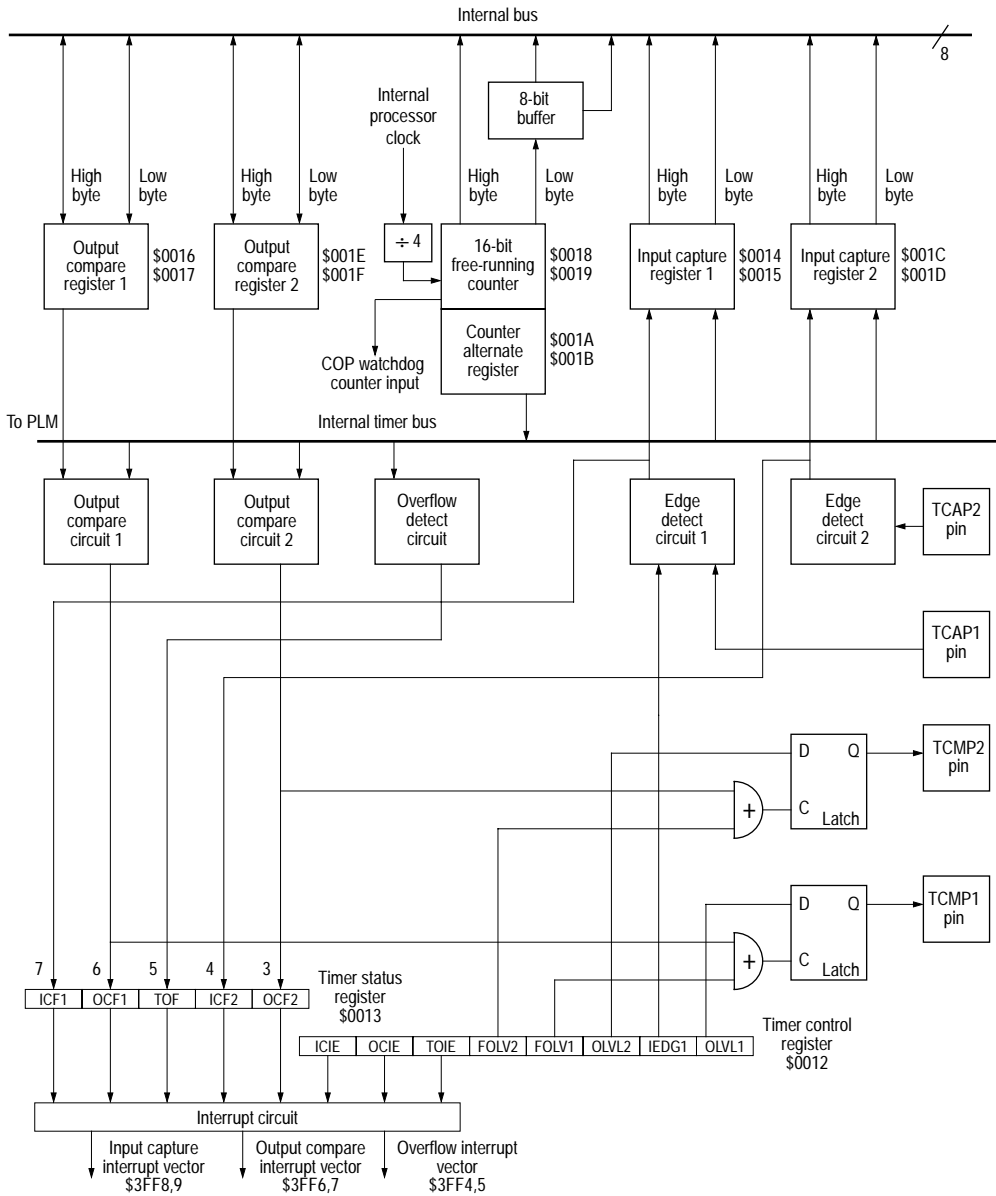

Figure 6-1 16-bit programmable timer block diagram

6.1.1 Counter register and alternate counter register

	Address	bit 7	bit 6	bit 5	bit 4	bit 3	bit 2	bit 1	bit 0	State on reset
Timer counter high	\$0018									1111 1111
Timer counter low	\$0019									1111 1100

	Address	bit 7	bit 6	bit 5	bit 4	bit 3	bit 2	bit 1	bit 0	State on reset
Alternate counter high	\$001A									1111 1111
Alternate counter low	\$001B									1111 1100

The double-byte, free-running counter can be read from either of two locations, \$18-\$19 (counter register) or \$1A-\$1B (alternate counter register). A read from only the less significant byte (LSB) of the free-running counter (\$19 or \$1B) receives the count value at the time of the read. If a read of the free-running counter or alternate counter register first addresses the more significant byte (MSB) (\$18 or \$1A), the LSB is transferred to a buffer. This buffer value remains fixed after the first MSB read, even if the user reads the MSB several times. This buffer is accessed when reading the free-running counter or alternate counter register LSB and thus completes a read sequence of the total counter value. In reading either the free-running counter or alternate counter register, if the MSB is read, the LSB must also be read to complete the sequence. If the timer overflow flag (TOF) is set when the counter register LSB is read then a read of the timer status register (TSR) will clear the flag.

The alternate counter register differs from the counter register only in that a read of the LSB does not clear TOF. Therefore, where it is critical to avoid the possibility of missing timer overflow interrupts due to clearing of TOF, the alternate counter register should be used.

The free-running counter is set to \$FFFC during power-on and external reset and is always a read-only register. During a power-on reset, the counter begins running after the oscillator start-up delay. Because the free-running counter is 16 bits preceded by a fixed divide-by-4 prescaler, the value in the free-running counter repeats every 262,144 internal bus clock cycles. TOF is set when the counter overflows (from \$FFFF to \$0000); this will cause an interrupt if TOIE is set.

In some particular timing control applications it may be desirable to reset the 16-bit free running counter under software control. When the low byte of the counter (\$19 or \$1B) is written to, the counter is configured to its reset value (\$FFFC).

The divide-by-4 prescaler is also reset and the counter resumes normal counting operation. All of the flags and enable bits remain unaltered by this operation. If access has previously been made to the high byte of the free-running counter (\$18 or \$1A), then the reset counter operation terminates the access sequence.

Warning: This operation may affect the function of the watchdog system (see [Section 10.1.4](#)). The PLM results will also be affected while resetting the counter.

6.2 Timer control and status

The various functions of the timer are monitored and controlled using the timer control and status registers described below.

6.2.1 Timer control register (TCR)

The timer control register (\$0012) is used to enable the input captures (ICIE), output compares (OCIE), and timer overflow (TOIE) functions as well as forcing output compares (FOLV1 and FOLV2), selecting input edge sensitivity (IEDG1) and levels of output polarity (OLV1 and OLV2).

Address	bit 7	bit 6	bit 5	bit 4	bit 3	bit 2	bit 1	bit 0	State on reset	
Timer control (TCR)	\$0012	ICIE	OCIE	TOIE	FOLV2	FOLV1	OLV2	IEDG1	OLV1	0000 00u0

6

ICIE — Input captures interrupt enable

If this bit is set, a timer interrupt is enabled whenever the ICF1 or ICF2 status flag (in the timer status register) is set.

- 1 (set) – Interrupt enabled.
- 0 (clear) – Interrupt disabled.

OCIE — Output compares interrupt enable

If this bit is set, a timer interrupt is enabled whenever the OCF1 or OCF2 status flag (in the timer status register) is set.

- 1 (set) – Interrupt enabled.
- 0 (clear) – Interrupt disabled.

TOIE — Timer overflow interrupt enable

If this bit is set, a timer interrupt is enabled whenever the TOF status flag (in the timer status register) is set.

- 1 (set) – Interrupt enabled.
- 0 (clear) – Interrupt disabled.

FOLV2 — Force output compare 2

This bit always reads as zero, hence writing a zero to this bit has no effect. Writing a one at this position will force the OLV2 bit to the corresponding output level latch, thus appearing at the TCMP2 pin. Note that this bit does not affect the OCF2 bit of the status register (see [Section 6.4.3](#)).

- 1 (set) — OLV2 bit forced to output level latch.
- 0 (clear) — No effect.

FOLV1 — Force output compare 1

This bit always reads as zero, hence writing a zero to this bit has no effect. Writing a one at this position will force the OLV1 bit to the corresponding output level latch, thus appearing at the TCMP1 pin. Note that this bit does not affect the OCF1 bit of the status register (see [Section 6.4.3](#)).

- 1 (set) — OLV1 bit forced to output level latch.
- 0 (clear) — No effect.

OLV2 — Output level 2

When OLV2 is set a high output level will be clocked into the output level register by the next successful output compare, and will appear on the TCMP2 pin. When clear, it will be a low level which will appear on the TCMP2 pin.

- 1 (set) — A high output level will appear on the TCMP2 pin.
- 0 (clear) — A low output level will appear on the TCMP2 pin.

IEDG1 — Input edge 1

When IEDG1 is set, a positive-going edge on the TCAP1 pin will trigger a transfer of the free-running counter value to the input capture register 1. When clear, a negative-going edge triggers the transfer.

- 1 (set) — TCAP1 is positive-going edge sensitive.
- 0 (clear) — TCAP1 is negative-going edge sensitive.

Note: There is no need for an equivalent bit for the input capture register 2 as TCAP2 is negative-going edge sensitive only.

OLV1 — Output level 1

When OLV1 is set a high output level will be clocked into the output level register by the next successful output compare, and will appear on the TCMP1 pin. When clear, it will be a low level which will appear on the TCMP1 pin.

- 1 (set) — A high output level will appear on the TCMP1 pin.
- 0 (clear) — A low output level will appear on the TCMP1 pin.

6.2.2 Timer status register (TSR)

The timer status register (\$13) contains the status bits corresponding to the timer interrupt conditions – ICF1, OCF1, TOF, ICF2 and OCF2.

Accessing the timer status register satisfies the first condition required to clear the status bits. The remaining step is to access the register corresponding to the status bit.

Address	bit 7	bit 6	bit 5	bit 4	bit 3	bit 2	bit 1	bit 0	State on reset
Timer status (TSR)	\$0013	ICF1	OCF1	TOF	ICF2	OCF2			Undefined

ICF1 — Input capture flag 1

This bit is set when the selected polarity of edge is detected by the input capture edge detector 1 at TCAP1; an input capture interrupt will be generated, if ICIE is set. ICF1 is cleared by reading the TSR and then the input capture low register 1 (\$15).

- 1 (set) – A valid input capture has occurred.
- 0 (clear) – No input capture has occurred.

OCF1 — Output compare flag 1

This bit is set when the output compare 1 register contents match those of the free-running counter; an output compare interrupt will be generated if OCIE is set. OCF1 is cleared by reading the TSR and then the output compare 1 low register (\$17).

- 1 (set) – A valid output compare has occurred.
- 0 (clear) – No output compare has occurred.

TOF — Timer overflow status flag

This bit is set when the free-running counter overflows from \$FFFF to \$0000; a timer overflow interrupt will occur if TOIE is set. TOF is cleared by reading the TSR and the counter low register (\$19).

- 1 (set) – Timer overflow has occurred.
- 0 (clear) – No timer overflow has occurred.

When using the timer overflow function and reading the free-running counter at random times to measure an elapsed time, a problem may occur whereby the timer overflow flag is unintentionally cleared if:

- 1 The timer status register is read or written when TOF is set, and
- 2 The LSB of the free-running counter is read, but not for the purpose of servicing the flag.

Reading the alternate counter register instead of the counter register will avoid this potential problem.

ICF2 — Input capture flag 2

This bit is set when a negative edge is detected by the input capture edge detector 2 at TCAP2; an input capture interrupt will be generated if ICIE is set. ICF2 is cleared by reading the TSR and then the input capture low register 2 (\$1D).

- 1 (set) – A valid (negative) input capture has occurred.
- 0 (clear) – No input capture has occurred.

OCF2 — Output compare flag 2

This bit is set when the output compare 2 register contents match those of the free-running counter; an output compare interrupt will be generated if OCIE is set. OCF2 is cleared by reading the TSR and then the output compare 2 low register (\$1F).

- 1 (set) – A valid output compare has occurred.
- 0 (clear) – No output compare has occurred.

6.3 Input capture

'Input capture' is a technique whereby an external signal is used to trigger a read of the free running counter. In this way it is possible to relate the timing of an external signal to the internal counter value, and hence to elapsed time.

There are two input capture registers: input capture register 1 (ICR1) and input capture register 2 (ICR2).

The same input capture interrupt enable bit (ICIE) is used for the two input captures.

6.3.1 Input capture register 1 (ICR1)

	Address	bit 7	bit 6	bit 5	bit 4	bit 3	bit 2	bit 1	bit 0	State on reset
Input capture high 1	\$0014									Undefined
Input capture low 1	\$0015									Undefined

The two 8-bit registers that make up the 16-bit input capture register 1 are read-only, and are used to latch the value of the free-running counter after the input capture edge detector circuit 1 senses a valid transition at TCAP1. The level transition that triggers the counter transfer is defined by the input edge bit (IEDG1). When an input capture 1 occurs, the corresponding flag ICF1 in TSR is set. An interrupt can also accompany an input capture 1 provided the ICIE bit in TCR is set. The 8 most significant bits are stored in the input capture high 1 register at \$14, the 8 least significant bits in the input capture low 1 register at \$15.

The result obtained from an input capture will be one greater than the value of the free-running counter on the rising edge of the internal bus clock preceding the external transition. This delay is required for internal synchronization. Resolution is one count of the free-running counter, which is four internal bus clock cycles. The free-running counter contents are transferred to the input capture register 1 on each valid signal transition whether the input capture 1 flag (ICF1) is set or clear. The input capture register 1 always contains the free-running counter value that corresponds to the most recent input capture 1. After a read of the input capture 1 register MSB (\$14), the counter transfer is inhibited until the LSB (\$15) is also read. This characteristic causes the time used in the input capture software routine and its interaction with the main program to determine the minimum pulse period. A read of the input capture 1 register LSB (\$15) does not inhibit the free-running counter transfer since the two actions occur on opposite edges of the internal bus clock.

Reset does not affect the contents of the input capture 1 register, except when exiting STOP mode (see [Section 6.6](#)).

6.3.2 Input capture register 2 (ICR2)

	Address	bit 7	bit 6	bit 5	bit 4	bit 3	bit 2	bit 1	bit 0	State on reset
Input capture high 2	\$001C									Undefined
Input capture low 2	\$001D									Undefined

The two 8-bit registers that make up the 16-bit input capture register 2 are read-only, and are used to latch the value of the free-running counter after the input capture edge detector circuit 2 senses a negative transition at pin TCAP2. When an input capture 2 occurs, the corresponding flag ICF2 in TSR is set. An interrupt can also accompany an input capture 2 provided the ICIE bit in TCR is set. The 8 most significant bits are stored in the input capture 2 high register at \$1C, the 8 least significant bits in the input capture 2 low register at \$1D.

The result obtained from an input capture will be one greater than the value of the free-running counter on the rising edge of the internal bus clock preceding the external transition. This delay is required for internal synchronization. Resolution is one count of the free-running counter, which is four internal bus clock cycles. The free-running counter contents are transferred to the input capture register 2 on each negative signal transition whether the input capture 2 flag (IC2F) is set or clear. The input capture register 2 always contains the free-running counter value that corresponds to the most recent input capture 2. After a read of the input capture register 2 MSB (\$1C), the counter transfer is inhibited until the LSB (\$1D) is also read. This characteristic causes the time used in the input capture software routine and its interaction with the main program to determine the minimum pulse period. A read of the input capture register 2 LSB (\$1C) does not inhibit the free-running counter transfer since the two actions occur on opposite edges of the internal bus clock.

Reset does not affect the contents of the input capture 2 register, except when exiting STOP mode (see [Section 6.6](#)).

6.4 Output compare

'Output compare' is a technique which may be used, for example, to generate an output waveform, or to signal when a specific time period has elapsed, by presetting the output compare register to the appropriate value.

There are two output compare registers: output compare register 1 (OCR1) and output compare register 2 (OCR2).

Note: The same output compare interrupt enable bit (OCIE) is used for the two output compares.

6.4.1 Output compare register 1 (OCR1)

	Address	bit 7	bit 6	bit 5	bit 4	bit 3	bit 2	bit 1	bit 0	State on reset
Output compare high 1	\$0016									Undefined
Output compare low 1	\$0017									Undefined

The 16-bit output compare register 1 is made up of two 8-bit registers at locations \$16 (MSB) and \$17 (LSB). The contents of the output compare register 1 are compared with the contents of the free-running counter continually and, if a match is found, the corresponding output compare flag (OCF1) in the timer status register is set and the output level (OLVL1) is transferred to pin TCMP1. The output compare register 1 values and the output level bit should be changed after each successful comparison to establish a new elapsed timeout. An interrupt can also accompany a successful output compare provided the corresponding interrupt enable bit (OCIE) is set. (The free-running counter is updated every four internal bus clock cycles.)

After a processor write cycle to the output compare register 1 containing the MSB (\$16), the output compare function is inhibited until the LSB (\$17) is also written. The user must write both bytes (locations) if the MSB is written first. A write made only to the LSB (\$17) will not inhibit the compare 1 function. The processor can write to either byte of the output compare register 1 without affecting the other byte. The output level (OLVL1) bit is clocked to the output level register and hence to the TCMP1 pin whether the output compare flag 1 (OCF1) is set or clear. The minimum time required to update the output compare register 1 is a function of the program rather than the internal hardware. Because the output compare flag 1 and the output compare register 1 are not defined at power on, and not affected by reset, care must be taken when initializing output compare functions with software. The following procedure is recommended:

- Write to output compare high 1 to inhibit further compares;
- Read the timer status register to clear OCF1 (if set);
- Write to output compare low 1 to enable the output compare 1 function.

The purpose of this procedure is to prevent the OCF1 bit from being set between the time it is read and the write to the corresponding output compare register.

All bits of the output compare register are readable and writable and are not altered by the timer hardware or reset. If the compare function is not needed, the two bytes of the output compare register can be used as storage locations.

6.4.2 Output compare register 2 (OCR2)

	Address	bit 7	bit 6	bit 5	bit 4	bit 3	bit 2	bit 1	bit 0	State on reset
Output compare high 2	\$001E									Undefined
Output compare low 2	\$001F									Undefined

6

The 16-bit output compare register 2 is made up of two 8-bit registers at locations \$1E (MSB) and \$1F (LSB). The contents of the output compare register 2 are compared with the contents of the free-running counter continually and, if a match is found, the corresponding output compare flag (OCF2) in the timer status register is set and the output level (OLVL2) is transferred to pin TCMP2. The output compare register 2 values and the output level bit should be changed after each successful comparison to establish a new elapsed timeout. An interrupt can also accompany a successful output compare provided the corresponding interrupt enable bit (OCIE) is set. (The free-running counter is updated every four internal bus clock cycles.)

After a processor write cycle to the output compare register 2 containing the MSB (\$1E), the output compare function is inhibited until the LSB (\$1F) is also written. The user must write both bytes (locations) if the MSB is written first. A write made only to the LSB (\$1F) will not inhibit the compare 2 function. The processor can write to either byte of the output compare register 2 without affecting the other byte. The output level (OLVL2) bit is clocked to the output level register and hence to the TCMP2 pin whether the output compare flag 2 (OCF2) is set or clear. The minimum time required to update the output compare register 2 is a function of the program rather than the internal hardware. Because the output compare flag 2 and the output compare register 2 are not defined at power on, and not affected by reset, care must be taken when initializing output compare functions with software. The following procedure is recommended:

- Write to output compare high 2 to inhibit further compares;
- Read the timer status register to clear OCF2 (if set);
- Write to output compare low 2 to enable the output compare 2 function.

The purpose of this procedure is to prevent the OCF1 bit from being set between the time it is read and the write to the corresponding output compare register.

All bits of the output compare register are readable and writable and are not altered by the timer hardware or reset. If the compare function is not needed, the two bytes of the output compare register can be used as storage locations.

6.4.3 Software force compare

A software force compare is required in many applications. To achieve this, bit 3 (FOLV1 for OCR1) and bit 4 (FOLV2 for OCR2) in the timer control register are used. These bits always read as ‘zero’, but a write to ‘one’ causes the respective OLVL1 or OLVL2 values to be copied to the respective output level (TCMP1 and TCMP2 pins).

Internal logic is arranged such that in a single instruction, one can change OLVL1 and/or OLVL2, at the same time causing a forced output compare with the new values of OLVL1 and OLVL2. In conjunction with normal compare, this function allows a wide range of applications including fixed frequency generation.

Note: A software force compare will affect the corresponding output pin TCMP1 and/or TCMP2, but will not affect the compare flag, thus it will not generate an interrupt.

6.5 Pulse length modulation (PLM)

The programmable timer works in conjunction with the PLM system to execute two 8-bit D/A PLM conversions, with a choice of two repetition rates (see [Section 8](#)).

6.5.1 Pulse length modulation registers A and B (PLMA/PLMB)

	Address	bit 7	bit 6	bit 5	bit 4	bit 3	bit 2	bit 1	bit 0	State on reset
Pulse length modulation A (PLMA)	\$000A									0000 0000
Pulse length modulation B (PLMB)	\$000B									0000 0000

6.6 Timer during STOP mode

When the MCU enters STOP mode, the timer counter stops counting and remains at that particular count value until STOP mode is exited by an interrupt. If STOP mode is exited by power-on or external reset, the counter is forced to \$FFFC but if it is exited by external interrupt (\overline{IRQ}) then the counter resumes from its stopped value.

Another feature of the programmable timer is that if at least one valid input capture edge occurs at one of the TCAP pins while in STOP mode, the corresponding input capture detect circuitry is armed. This action does not wake the MCU or set any timer flags, but when the MCU does wake-up there will be an active input capture flag (and data) from that first valid edge which occurred during STOP mode.

If STOP mode is exited by an external reset then no such input capture flag or data action takes place even if there was a valid input capture edge (at one of the TCAP pins) during STOP mode.

6

6.7 Timer during WAIT mode

The timer system is not affected by WAIT mode and continues normal operation. Any valid timer interrupt will wake-up the system.

6.8 Timer state diagrams

The relationships between the internal clock signals, the counter contents and the status of the flag bits are shown in the following figures. It should be noted that the signals labelled 'internal' (processor clock, timer clocks and reset) are not available to the user.

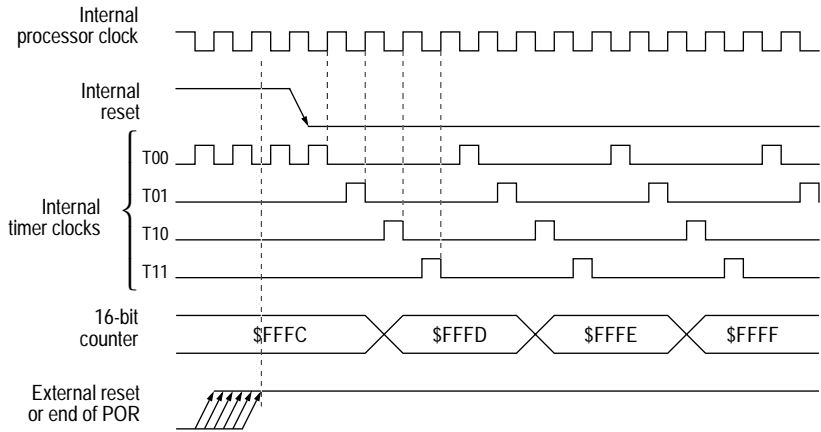

Note: The counter and timer control registers are the only ones affected by power-on or external reset.

Figure 6-2 Timer state timing diagram for reset

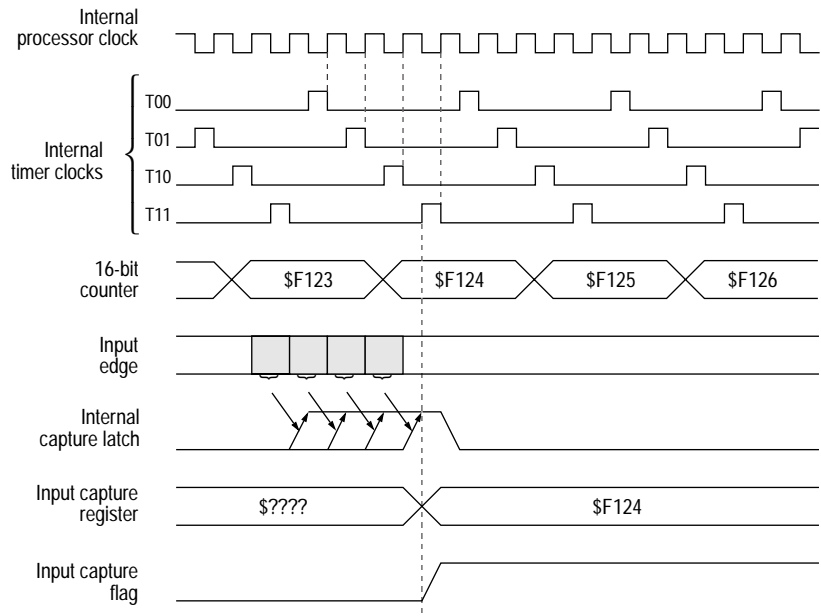

Note: If the input edge occurs in the shaded area from one timer state T10 to the next timer state T10, then the input capture flag will be set during the next T11 state.

Figure 6-3 Timer state timing diagram for input capture

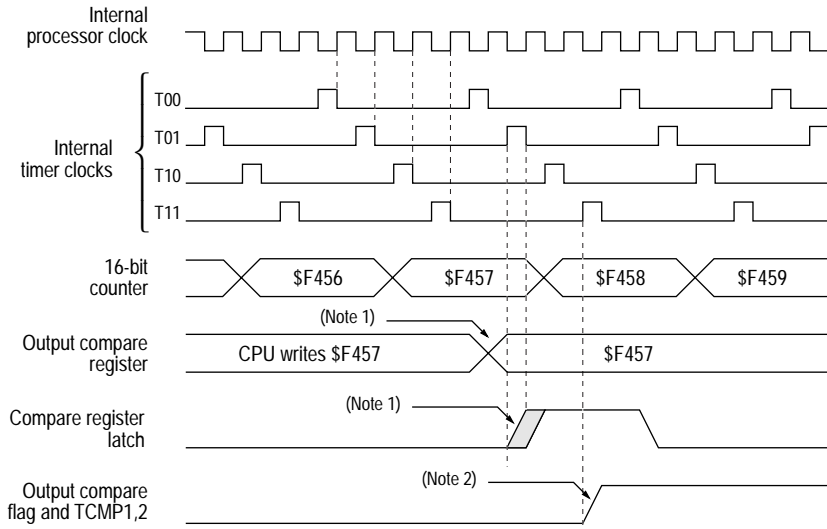

Note: The CPU write to the compare registers may take place at any time, but a compare only occurs at timer state T01. Thus a four cycle difference may exist between the write to the compare register and the actual compare.

Figure 6-4 Timer state timing diagram for output compare

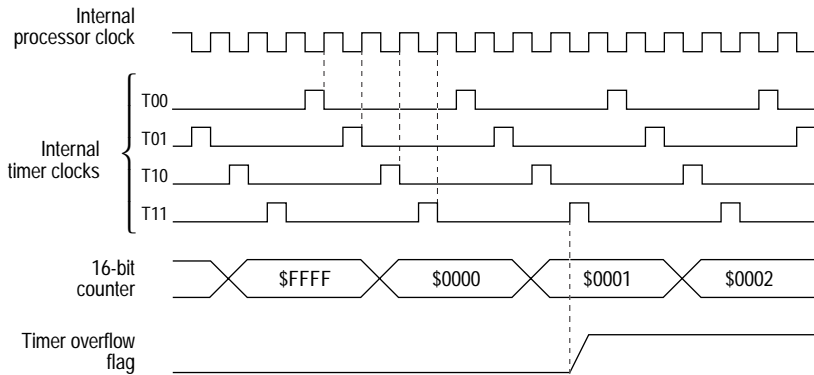

Note: The timer overflow flag is set at timer state T11 (transition of counter from \$FFFF to \$0000). It is cleared by a read of the timer status register during the internal processor clock high time, followed by a read of the counter low register.

Figure 6-5 Timer state timing diagram for timer overflow

7

SERIAL COMMUNICATIONS INTERFACE

A full-duplex asynchronous serial communications interface (SCI) is provided with a standard non-return-to-zero (NRZ) format and a variety of baud rates. The SCI transmitter and receiver are functionally independent and have their own baud rate generator; however they share a common baud rate prescaler and data format.

The serial data format is standard mark/space (NRZ) and provides one start bit, eight or nine data bits, and one stop bit.

The SCLK pin is the output of the transmitter clock. It outputs the transmitter data clock for synchronous transmission (no clocks on start bit and stop bit, and a software option to send clock on last data bit). This allows control of peripherals containing shift registers (e.g. LCD drivers). Phase and polarity of these clocks are software programmable.

Any SCI bidirectional communication requires a two-wire system: receive data in (RDI) and transmit data out (TDO).

'Baud' and 'bit rate' are used synonymously in the following description.

7

7.1 SCI two-wire system features

- Standard NRZ (mark/space) format
- Advanced error detection method with noise detection for noise duration of up to 1/16th bit time
- Full-duplex operation (simultaneous transmit and receive)
- 32 software selectable baud rates
- Different baud rates for transmit and receive; for each transmit baud rate, 8 possible receive baud rates
- Software selectable word length (eight or nine bits)
- Separate transmitter and receiver enable bits
- Capable of being interrupt driven
- Transmitter clocks available without altering the regular transmitter or receiver functions
- Four separate enable bits for interrupt control

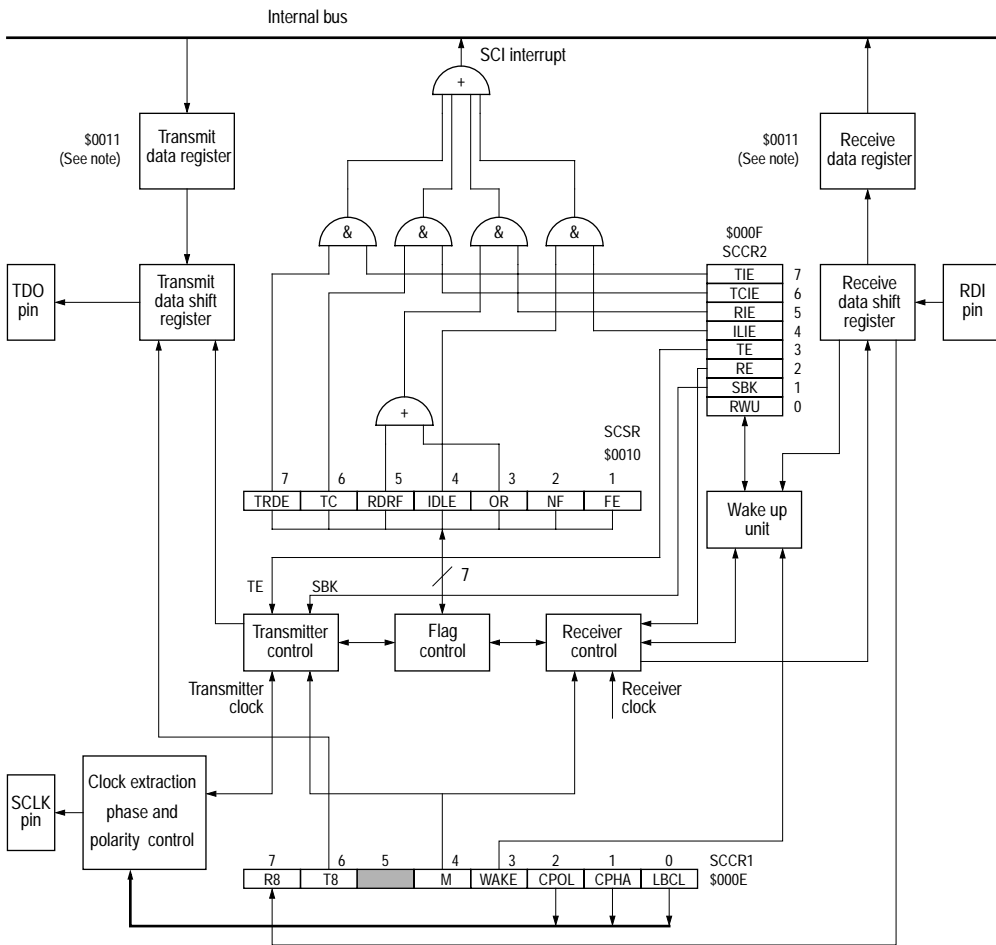

Note: The serial communications data register (SCI SCDR) is controlled by the internal R/\overline{W} signal. It is the transmit data register when written to and the receive data register when read.

Figure 7-1 Serial communications interface block diagram

7.2 SCI receiver features

- Receiver wake-up function (idle line or address bit)
- Idle line detection
- Framing error detection
- Noise detection
- Overrun detection
- Receiver data register full flag

7.3 SCI transmitter features

- Transmit data register empty flag
- Transmit complete flag
- Send break

7.4 Functional description

A block diagram of the SCI is shown in [Figure 7-1](#). Option bits in serial control register 1 (SCCR1) select the 'wake-up' method (WAKE bit) and data word length (M bit) of the SCI. SCCR2 provides control bits that individually enable the transmitter and receiver, enable system interrupts and provide the wake-up enable bit (RWU) and the send break code bit (SBK). Control bits in the baud rate register (BAUD) allow the user to select one of 32 different baud rates for the transmitter and receiver (see [Section 7.11.5](#)).

Data transmission is initiated by writing to the serial communications data register (SCDR). Provided the transmitter is enabled, data stored in the SCDR is transferred to the transmit data shift register. This transfer of data sets the transmit data register empty flag (TDRE) in the SCI status register (SCSR) and generates an interrupt (if transmitter interrupts are enabled). The transfer of data to the transmit data shift register is synchronized with the bit rate clock (see [Figure 7-2](#)). All data is transmitted least significant bit first. Upon completion of data transmission, the transmission complete flag (TC) in the SCSR is set (provided no pending data, preamble or break is to be sent) and an interrupt is generated (if the transmit complete interrupt is enabled). If the transmitter is disabled, and the data, preamble or break (in the transmit data shift register) has been sent, the TC bit will also be set. This will also generate an interrupt if the transmission complete interrupt enable bit (TCIE) is set. If the transmitter is disabled during a transmission, the character being transmitted will be completed before the transmitter gives up control of the TDO pin.

When SCDR is read, it contains the last data byte received, provided that the receiver is enabled. The receive data register full flag bit (RDRF) in the SCSR is set to indicate that a data byte has been transferred from the input serial shift register to the SCDR; this will cause an interrupt if the receiver interrupt is enabled. The data transfer from the input serial shift register to the SCDR is synchronized by the receiver bit rate clock. The OR (overrun), NF (noise), or FE (framing) error flags in the SCSR may be set if data reception errors occurred.

An idle line interrupt is generated if the idle line interrupt is enabled and the IDLE bit (which detects idle line transmission) in SCSR is set. This allows a receiver that is not in the wake-up mode to detect the end of a message or the preamble of a new message, or to resynchronize with the transmitter. A valid character must be received before the idle line condition or the IDLE bit will not be set and idle line interrupt will not be generated.

The SCP0 and SCP1 bits function as a prescaler for SCR0–SCR2 to generate the receiver baud rate and for SCT0–SCT2 to generate the transmitter baud rate. Together, these eight bits provide multiple transmitter/receiver rate combinations for a given crystal frequency (see Figure 7-2). This register should only be written to while both the transmitter and receiver are disabled (TE=0, RE=0).

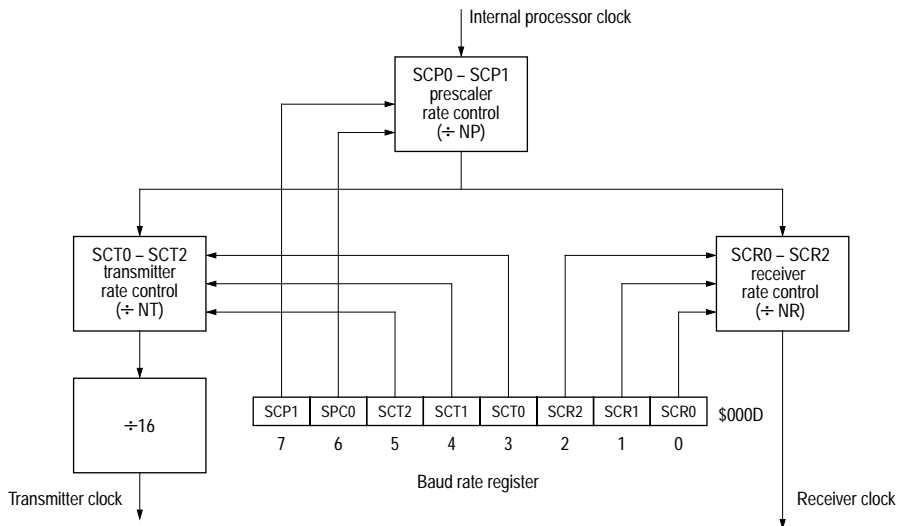

Note: There is a fixed rate divide-by-16 before the transmitter to compensate for the inherent divide-by-16 of the receiver (sampling). This means that by loading the same value for both the transmitter and receiver baud rate selector, the same baud rates can be obtained.

Figure 7-2 SCI rate generator division

7.5 Data format

Receive data or transmit data is the serial data that is transferred to the internal data bus from the receive data input pin (RDI) or from the internal bus to the transmit data output pin (TDO). The non-return-to-zero (NRZ) data format shown in Figure 7-3 is used and must meet the following criteria:

- The idle line is brought to a logic one state prior to transmission/reception of a character.
- A start bit (logic zero) is used to indicate the start of a frame.
- The data is transmitted and received least significant bit first.
- A stop bit (logic one) is used to indicate the end of a frame. A frame consists of a start bit, a character of eight or nine data bits, and a stop bit.
- A break is defined as the transmission or reception of a low (logic zero) for at least one complete frame time (10 zeros for 8-bit format, 11 zeros for 9-bit).

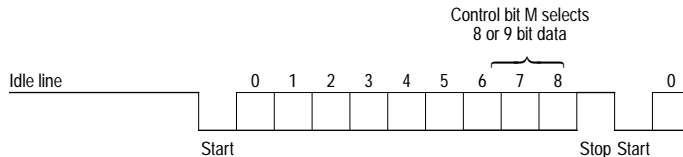

Figure 7-3 Data format

7.6 Receiver wake-up operation

The receiver logic hardware also supports a receiver wake-up function which is intended for systems having more than one receiver. With this function a transmitting device directs messages to an individual receiver or group of receivers by passing addressing information as the initial byte(s) of each message. The wake-up function allows receivers not addressed to remain in a dormant state for the remainder of the unwanted message. This eliminates any further software overhead to service the remaining characters of the unwanted message and thus improves system performance.

The receiver is placed in wake-up mode by setting the receiver wake-up bit (RWU) in the SCCR2 register. While RWU is set, all of the receiver related status flags (RDRF, IDLE, OR, NF, and FE) are inhibited (cannot become set). Note that the idle line detect function is inhibited while the RWU bit is set. Although RWU may be cleared by a software write to SCCR2, it would be unusual to do so. Normally RWU is set by software and is cleared automatically in hardware by one of the two methods described below.

7.6.1 Idle line wake-up

In idle line wake-up mode, a dormant receiver wakes up as soon as the RDI line becomes idle. Idle is defined as a continuous logic high level on the RDI line for ten (or eleven) full bit times. Systems using this type of wake-up must provide at least one character time of idle between messages to wake up sleeping receivers, but must not allow any idle time between characters within a message.

7.6.2 Address mark wake-up

In address mark wake-up, the most significant bit (MSB) in a character is used to indicate whether it is an address (1) or data (0) character. Sleeping receivers will wake up whenever an address character is received. Systems using this method for wake-up would set the MSB of the first character of each message and leave it clear for all other characters in the message. Idle periods may be present within messages and no idle time is required between messages for this wake-up method.

7

7.7 Receive data in (RDI)

Receive data is the serial data that is applied through the input line and the SCI to the internal bus. The receiver circuitry clocks the input at a rate equal to 16 times the baud rate. This time is referred to as the RT rate in [Figure 7-4](#) and as the receiver clock in [Figure 7-2](#).

The receiver clock generator is controlled by the baud rate register, as shown in [Figure 7-1](#) and [Figure 7-2](#); however, the SCI is synchronized by the start bit, independent of the transmitter.

Once a valid start bit is detected, the start bit, each data bit and the stop bit are sampled three times at RT intervals 8 RT, 9 RT and 10 RT (1 RT is the position where the bit is expected to start), as shown in [Figure 7-5](#). The value of the bit is determined by voting logic which takes the value of the majority of the samples. A noise flag is set when all three samples on a valid start bit or data bit or the stop bit do not agree.

7.8 Start bit detection

When the input (idle) line is detected low, it is tested for three more sample times (referred to as the start edge verification samples in [Figure 7-4](#)). If at least two of these three verification samples detect a logic zero, a valid start bit has been detected, otherwise the line is assumed to be idle. A noise flag is set if one of the three verification samples detect a logic one, thus a valid start bit could be assumed with a set noise flag present.

If there has been a framing error without detection of a break (10 zeros for 8 bit format or 11 zeros for 9 bit format), the circuit continues to operate as if there actually was a stop bit, and the start

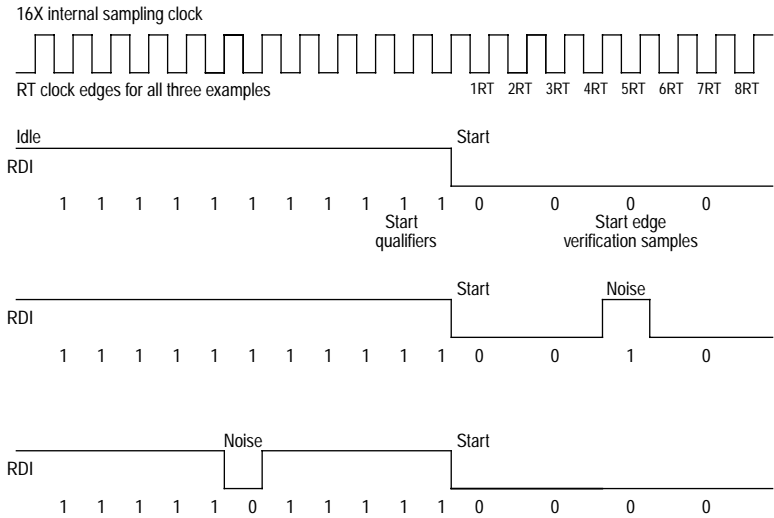

Figure 7-4 SCI examples of start bit sampling technique

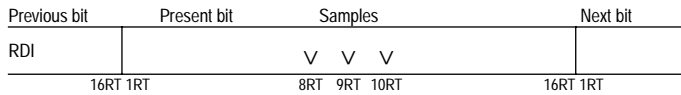
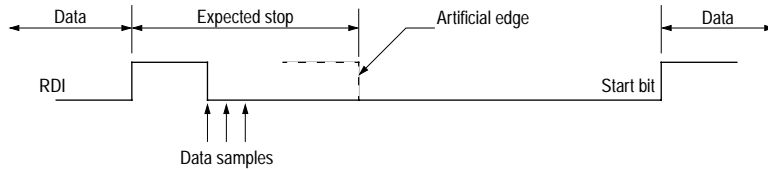

Figure 7-5 SCI sampling technique used on all bits

edge will be placed artificially. The last bit received in the data shift register is inverted to a logic one, and the three logic one start qualifiers (shown in [Figure 7-4](#)) are forced into the sample shift register during the interval when detection of a start bit is anticipated (see [Figure 7-6](#)); therefore, the start bit will be accepted no sooner than it is anticipated.

If the receiver detects that a break (RDRF = 1, FE = 1, receiver data register = \$0000) produced the framing error, the start bit will not be artificially induced and the receiver must actually detect a logic one before the start bit can be recognised (see [Figure 7-7](#)).



a) Case 1: receive line low during artificial edge

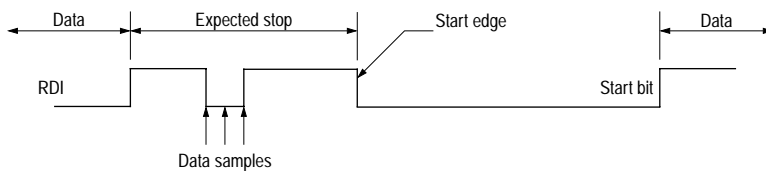

b) Case 2: receive line high during expected start edge

Figure 7-6 Artificial start following a framing error

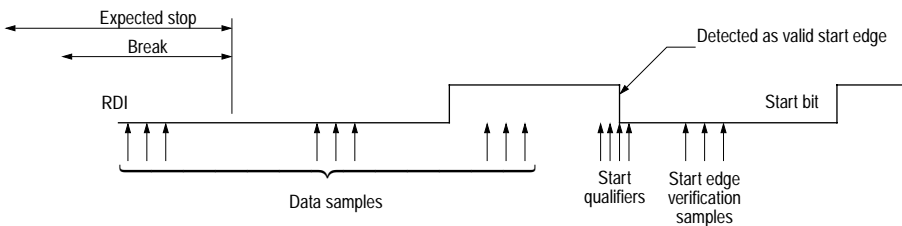

Figure 7-7 SCI start bit following a break

7.9 Transmit data out (TDO)

Transmit data is the serial data from the internal data bus that is applied through the SCI to the output line. Data format is as discussed in [Section 7.5](#) and shown in [Figure 7-3](#). The transmitter generates a bit time by using a derivative of the RT clock, thus producing a transmission rate equal to 1/16th that of the receiver sample clock (assuming the same baud rate is selected for both the receiver and transmitter).

7.10 SCI synchronous transmission

The SCI transmitter allows the user to control a one way synchronous serial transmission. The SCLK pin is the clock output of the SCI transmitter. No clocks are sent to that pin during start bit and stop bit. Depending on the state of the LBCL bit (bit 0 of SCCR1), clocks will or will not be activated during the last valid data bit (address mark). The CPOL bit (bit 2 of SCCR1) allows the user to select the clock polarity, and the CPHA bit (bit 1 of SCCR1) allows the user to select the phase of the external clock (see [Figure 7-8](#), [Figure 7-9](#) and [Figure 7-10](#)).

During idle, preamble and send break, the external SCLK clock is not activated.

These options allow the user to serially control peripherals which consist of shift registers, without losing any functions of the SCI transmitter which can still talk to other SCI receivers. These options do not affect the SCI receiver which is independent of the transmitter.

The SCLK pin works in conjunction with the TDO pin. When the SCI transmitter is disabled (TE = 0), the SCLK and TDO pins go to the high impedance state.

Note: The LBCL, CPOL and CPHA bits have to be selected before enabling the transmitter to ensure that the clocks function correctly. These bits should not be changed while the transmitter is enabled.

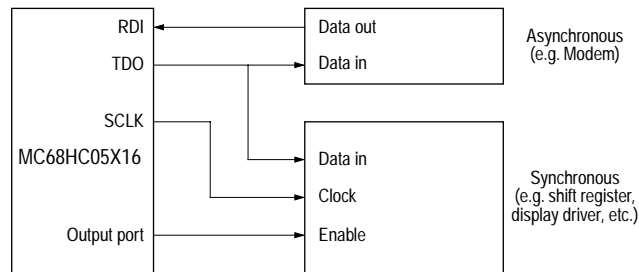

Figure 7-8 SCI example of synchronous and asynchronous transmission

7.11 SCI registers

The SCI system is configured and controlled by five registers: SCDR, SCCR1, SCCR2, SCSR, and BAUD.

7.11.1 Serial communications data register (SCDR)

	Address	bit 7	bit 6	bit 5	bit 4	bit 3	bit 2	bit 1	bit 0	State on reset
SCI data (SCDR)	\$0011									0000 0000

The SCDR is controlled by the internal R/\overline{W} signal and performs two functions in the SCI. It acts as the receive data register (RDR) when it is read and as the transmit data register (TDR) when it is written. [Figure 7-1](#) shows this register as two separate registers, RDR and TDR. The RDR provides the interface from the receive shift register to the internal data bus and the TDR provides the parallel interface from the internal data bus to the transmit shift register.

7

The receive data register is a read-only register containing the last byte of data received from the shift register for the internal data bus. The RDR full bit (RDRF) in the serial communications status register is set to indicate that a byte has been transferred from the input serial shift register to the SCDR. The transfer is synchronized with the receiver bit rate clock (from the receiver control) as shown in [Figure 7-1](#). All data is received with the least significant bit first.

The transmit data register (TDR) is a write-only register containing the next byte of data to be applied to the transmit shift register from the internal data bus. As long as the transmitter is enabled, data stored in the SCDR is transferred to the transmit shift register (after the current byte in the shift register has been transmitted).

The transfer is synchronized with the transmitter bit rate clock (from the transmitter control) as shown in [Figure 7-1](#). All data is received with the least significant bit first.

7.11.2 Serial communications control register 1 (SCCR1)

	Address	bit 7	bit 6	bit 5	bit 4	bit 3	bit 2	bit 1	bit 0	State on reset
SCI control 1 (SCCR1)	\$000E	R8	T8		M	WAKE	CPOL	CPHA	LBCL	Undefined

The SCI control register 1 (SCCR1) contains control bits related to the nine data bit character format, the receiver wake-up feature and the options to output the transmitter clocks for synchronous transmissions.

R8 — Receive data bit 8

This read-only bit is the ninth serial data bit received when the SCI system is configured for nine data bit operation ($M = 1$). The most significant bit (bit 8) of the received character is transferred into this bit at the same time as the remaining eight bits (bits 0–7) are transferred from the serial receive shift register to the SCI receive data register.

T8 — Transmit data bit 8

This read/write bit is the ninth data bit to be transmitted when the SCI system is configured for nine data bit operation ($M = 1$). When the eight low order bits (bits 0–7) of a transmit character are transferred from the SCI data register to the serial transmit shift register, this bit (bit 8) is transferred to the ninth bit position of the shift register.

M — Mode (select character format)

The read/write M-bit controls the character length for both the transmitter and receiver at the same time. The 9th data bit is most commonly used as an extra stop bit or it can also be used as a parity bit (see [Table 7-1](#)).

- 1 (set) — Start bit, 9 data bits, 1 stop bit.
- 0 (clear) — Start bit, 8 data bits, 1 stop bit.

Table 7-1 Method of receiver wake-up

WAKE	M	Method of receiver wake-up
0	x	Detection of an idle line allows the next data type received to cause the receive data register to fill and produce an RDRF flag.
1	0	Detection of a received one in the eighth data bit allows an RDRF flag and associated error flags.
1	1	Detection of a received one in the ninth data bit allows an RDRF flag and associated error flags.

x = Don't care

WAKE — Wake-up mode select

This bit allows the user to select the method for receiver wake-up. The WAKE bit can be read or written to any time. See [Table 7-1](#).

- 1 (set) — Wake-up on address mark; if RWU is set, SCI will wake-up if the 8th (if $M=0$) or the 9th (if $M=1$) bit received on the Rx line is set.
- 0 (clear) — Wake-up on idle line; if RWU is set, SCI will wake-up after 11 (if $M=0$) or 12 (if $M=1$) consecutive '1's on the Rx line.

CPOL – Clock polarity

This bit allows the user to select the polarity of the clocks to be sent to the SCLK pin. It works in conjunction with the CPHA bit to produce the desired clock-data relation (see [Figure 7-9](#) and [Figure 7-10](#)).

- 1 (set) – Steady high value at SCLK pin outside transmission window.
- 0 (clear) – Steady low value at SCLK pin outside transmission window.

This bit should not be manipulated while the transmitter is enabled.

CPHA – Clock phase

This bit allows the user to select the phase of the clocks to be sent to the SCLK pin. This bit works in conjunction with the CPOL bit to produce the desired clock-data relation (see [Figure 7-9](#) and [Figure 7-10](#)).

- 1 (set) – SCLK clock line activated at beginning of data bit.
- 0 (clear) – SCLK clock line activated in middle of data bit.

This bit should not be manipulated while the transmitter is enabled.

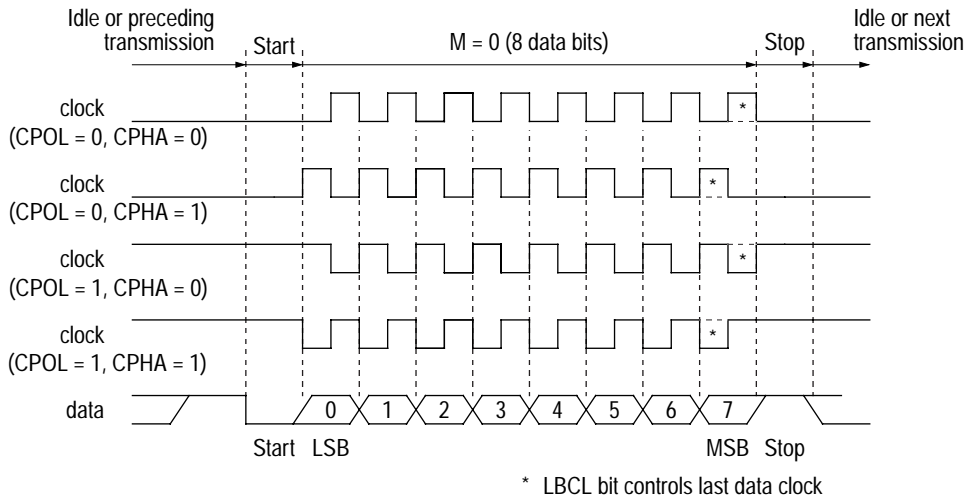

Figure 7-9 SCI data clock timing diagram (M=0)

7.11.3 Serial communications control register 2 (SCCR2)

The SCI control register 2 (SCCR2) provides the control bits that enable/disable individual SCI functions.

	Address	bit 7	bit 6	bit 5	bit 4	bit 3	bit 2	bit 1	bit 0	State on reset
SCI control (SCCR2)	\$000F	TIE	TCIE	RIE	ILIE	TE	RE	RWU	SBK	0000 0000

TIE — Transmit interrupt enable

- 1 (set) — TDRE interrupts enabled.
- 0 (clear) — TDRE interrupts disabled.

TCIE — Transmit complete interrupt enable

- 1 (set) — TC interrupts enabled.
- 0 (clear) — TC interrupts disabled.

RIE — Receiver interrupt enable

- 1 (set) — RDRF and OR interrupts enabled.
- 0 (clear) — RDRF and OR interrupts disabled.

ILIE — Idle line interrupt enable

- 1 (set) — IDLE interrupts enabled.
- 0 (clear) — IDLE interrupts disabled.

TE — Transmitter enable

When the transmit enable bit is set, the transmit shift register output is applied to the TDO line and the corresponding clocks are applied to the SCLK pin. Depending on the state of control bit M (SCCR1), a preamble of 10 (M = 0) or 11 (M = 1) consecutive ones is transmitted when software sets the TE bit from a cleared state.

If a transmission is in progress and a zero is written to TE, the transmitter will wait until after the present byte has been transmitted before placing the TDO and the SCLK pin in the idle, high impedance state.

If the TE bit has been written to a zero and then set to a one before the current byte is transmitted, the transmitter will wait for that byte to be transmitted and will then initiate transmission of a new preamble. After this latest transmission, and provided the TDRE bit is set (no new data to transmit), the line remains idle (driven high while TE = 1); otherwise, normal transmission occurs. This function allows the user to neatly terminate a transmission sequence.

After loading the last byte in the serial communications data register and receiving the TDRE flag, the user should clear TE. Transmission of the last byte will then be completed and the line will go idle.

1 (set) – Transmitter enabled.

0 (clear) – Transmitter disabled.

RE — Receiver enable

1 (set) – Receiver enabled.

0 (clear) – Receiver disabled.

When RE is clear (receiver disabled) all the status bits associated with the receiver (RDRF, IDLE, OR, NF and FE) are inhibited.

RWU — Receiver wake-up

When the receiver wake-up bit is set by the user software, it puts the receiver to sleep and enables the wake-up function. The type of wake-up mode for the receiver is determined by the WAKE bit discussed above (in the SCCR1). When the RWU bit is set, no status flags will be set. Flags which were set previously will not be cleared when RWU is set.

If the WAKE bit is cleared, RWU is cleared by the SCI logic after receiving 10 (M = 0) or 11 (M = 1) consecutive ones. Under these conditions, RWU cannot be set if the line is idle. If the WAKE bit is set, RWU is cleared after receiving an address bit. The RDRF flag will then be set and the address byte stored in the receiver data register.

SBK — Send break

If the send break bit is toggled set and cleared, the transmitter sends 10 (M = 0) or 11 (M = 1) zeros and then reverts to idle sending data. If SBK remains set, the transmitter will continually send whole blocks of zeros (sets of 10 or 11) until cleared. At the completion of the break code, the transmitter sends at least one high bit to guarantee recognition of a valid start bit.

7.11.4 Serial communications status register (SCSR)

Address	bit 7	bit 6	bit 5	bit 4	bit 3	bit 2	bit 1	bit 0	State on reset
SCI status (SCSR)	\$0010	TDRE	TC	RDRF	IDLE	OR	NF	FE	1100 000u

The serial communications status register (SCSR) provides inputs to the interrupt logic circuits for generation of the SCI system interrupt. In addition, a noise flag bit and a framing error bit are also contained in the SCSR.

TDRE — Transmit data register empty flag

This bit is set when the contents of the transmit data register are transferred to the serial shift register. New data will not be transmitted unless the SCSR register is read before writing to the transmit data register to clear the TDRE flag.

If the TDRE bit is clear, this indicates that the transfer has not yet occurred and a write to the serial communications data register will overwrite the previous value. The TDRE bit is cleared by accessing the serial communications status register (with TDRE set) followed by writing to the serial communications data register.

TC — Transmit complete flag

This bit is set to indicate that the SCI transmitter has no meaningful information to transmit (no data in shift register, no preamble, no break). When TC is set the serial line will go idle (continuous MARK). The TC bit is cleared by accessing the serial communications status register (with TC set) followed by writing to the serial communications data register. It does not inhibit the transmitter function in any way.

RDRF — Receive data register full flag

This bit is set when the contents of the receiver serial shift register are transferred to the receiver data register.

If multiple errors are detected in any one received word, the NF and RDRF bits will be affected as appropriate during the same clock cycle. The RDRF bit is cleared when the serial communications status register is accessed (with RDRF set) followed by a read of the serial communications data register.

IDLE — Idle line detected flag

This bit is set when a receiver idle line is detected (the receipt of a minimum of ten/eleven consecutive '1's). This bit will not be set by the idle line condition when the RWU bit is set. This allows a receiver that is not in the wake-up mode to detect the end of a message, detect the preamble of a new message or resynchronize with the transmitter. The IDLE bit is cleared by accessing the serial communications status register (with IDLE set) followed by a read of the serial communications data register. Once cleared, IDLE will not be set again until after RDRF has been set, (i.e. until after the line has been active and becomes idle again).

OR — Overrun error flag

This bit is set when a new byte is ready to be transferred from the receiver shift register to the receiver data register and the receive data register is already full (RDRF bit is set). Data transfer is inhibited until the RDRF bit is cleared. Data in the serial communications data register is valid in this case, but additional data received during an overrun condition (including the byte causing the overrun) will be lost.

The OR bit is cleared when the serial communications status register is accessed (with OR set) followed by a read of the serial communications data register.

NF — Noise error flag

This bit is set if there is noise on a 'valid' start bit, any of the data bits or on the stop bit. The NF bit is not set by noise on the idle line nor by invalid start bits. If there is noise, the NF bit is not set until the RDRF flag is set. Each data bit is sampled three times as described in [Section 7.7](#).

The NF bit represents the status of the byte in the serial communications data register. For the byte being received (shifted in) there will be also a 'working' noise flag, the value of which will be transferred to the NF bit when the serial data is loaded into the serial communications data register. The NF bit does not generate an interrupt because the RDRF bit gets set with NF and can be used to generate the interrupt.

The NF bit is cleared when the serial communications status register is accessed (with NF set) followed by a read of the serial communications data register.

FE — Framing error flag

This bit is set when the word boundaries in the bit stream are not synchronized with the receiver bit counter (generated by the reception of a logic zero bit where a stop bit was expected). The FE bit reflects the status of the byte in the receive data register and the transfer from the receive shift register to the receive data register is inhibited by an overrun. The FE bit is set during the same cycle as the RDRF bit but does not get set in the case of an overrun (OR). The framing error flag inhibits further transfer of data into the receive data register until it is cleared.

The FE bit is cleared when the serial communications status register is accessed (with FE set) followed by a read of the serial communications data register.

7.11.5 Baud rate register (BAUD)

The baud rate register provides the means to select two different or equivalent baud rates for the transmitter and receiver.

	Address	bit 7	bit 6	bit 5	bit 4	bit 3	bit 2	bit 1	bit 0	State on reset
SCI baud rate (BAUD)	\$000D	SCP1	SCP0	SCT2	SCT1	SCT0	SCR2	SCR1	SCR0	00uu uuuu

SCP1, SCP0 — Serial prescaler select bits

These read/write bits determine the prescale factor, NP, by which the internal processor clock is divided before it is applied to the transmitter and receiver rate control dividers, NT and NR. This common prescaled output is used as the input to a divider that is controlled by the SCR0–SCR2 bits for the SCI receiver, and by the SCT0–SCT2 bits for the transmitter.

Table 7-3 First prescaler stage

SCP1	SCP0	Prescaler division ratio (NP)
0	0	1
0	1	3
1	0	4
1	1	13

SCT2, SCT1, SCT0 — SCI rate select bits (transmitter)

These three read/write bits select the baud rates for the transmitter. The prescaler output is divided by the factors shown in [Table 7-4](#).

Table 7-4 Second prescaler stage (transmitter)

SCT2	SCT1	SCT0	Transmitter division ratio (NT)
0	0	0	1
0	0	1	2
0	1	0	4
0	1	1	8
1	0	0	16
1	0	1	32
1	1	0	64
1	1	1	128

SCR2, SCR1, SCR0 — SCI rate select bits (receiver)

These three read/write bits select the baud rates for the receiver. The prescaler output described above is divided by the factors shown in [Table 7-5](#).

Table 7-5 Second prescaler stage (receiver)

SCR2	SCR1	SCR0	Receiver division ratio (NR)
0	0	0	1
0	0	1	2
0	1	0	4
0	1	1	8
1	0	0	16
1	0	1	32
1	1	0	64
1	1	1	128

The following equations are used to calculate the receiver and transmitter baud rates:

$$\text{baudTx} = \frac{f_{\text{clk}}}{16 \cdot \text{NP} \cdot \text{NR}}$$

$$\text{baudRx} = \frac{f_{\text{clk}}}{16 \cdot \text{NP} \cdot \text{NR}}$$

where:

NP = prescaler divide ratio

NT = transmitter baud rate divide ratio

NR = receiver baud rate divide ratio

baudTx = transmitter baud rate

baudRx = receiver baud rate

f_{CLK} = CPU clock frequency

7.12 Baud rate selection

The flexibility of the baud rate generator allows many different baud rates to be selected, depending on the CPU clock frequency. A particular baud rate may be generated by manipulating the various prescaler and division ratio bits. Table 7-6, Table 7-7 and Table 7-8 show the highest baud rates that can be achieved for five typical crystal frequencies, for each of the CPU clock frequency options and only using the prescaler bits. Table 7-9 shows how lower transmitter or receiver baud rates may be obtained using a further division ratio provided by the SCI rate select bits. Note that the five examples given in Table 7-9 are representative samples only.

Table 7-6 SCI baud rate selection with CPU clock frequency = $f_{OSC}/2$

SCP1	SCP0	Clock divided by	Crystal frequency - f_{OSC} (MHz)				
			4.194304	4.00	2.4576	2.00	1.8432
0	0	1	131072	125000	76800	62500	57600
0	1	3	43691	41667	25600	20833	19200
1	0	4	32768	31250	19200	15625	14400
1	1	13	10082	9600	5907	4800	4430

Table 7-7 SCI baud rate selection with CPU clock frequency = $f_{OSC}/8$

SCP1	SCP0	Clock divided by	Crystal frequency - f_{OSC} (MHz)				
			16.00	8.00	4.9152	4.194304	2.4576
0	0	1	125000	62500	38400	32768	19200
0	1	3	41667	20833	12800	10082	14400
1	0	4	31250	15625	9600	8192	4430
1	1	13	9600	4800	2954	2521	1477

Table 7-8 SCI baud rate selection with CPU clock frequency = $f_{OSC}/10$

SCP1	SCP0	Clock divided by	Crystal frequency - f_{OSC} (MHz)				
			20.00	18.432	10.00	6.144	5.0
0	0	1	125000	115200	62500	38400	31250
0	1	3	41667	38400	20833	12800	10417
1	0	4	31250	28800	15625	9600	7813
1	1	13	9600	8861	4800	2954	2400

Note: The clock in the 'Clock divided by' column refers to the internal processor clock.

Table 7-9 SCI transmit baud rate output for a given prescaler output

SCT/SCR bits			Divide by	Representative highest prescaler baud rate output				
Bit 2	Bit 1	Bit 0		131072	32768	38400	19200	9600
0	0	0	1	131072	32768	38400	19200	9600
0	0	1	2	65536	16384	19200	9600	4800
0	1	0	4	32768	8192	9600	4800	2400
0	1	1	8	16384	4096	4800	2400	1200
1	0	0	16	8192	2048	2400	1200	600
1	0	1	32	4096	1024	1200	600	300
1	1	0	64	2048	512	600	300	150
1	1	1	128	1024	256	300	150	75

Note: The examples shown in [Table 7-6](#), [Table 7-7](#), [Table 7-8](#) and [Table 7-9](#) do not apply when the part is operating in slow mode (see [Section 2.2.3](#)).

For the receiver, the internal clock frequency is 16 times higher than the selected baud rate.

7.13 SCI during STOP mode

When the MCU enters STOP mode, the baud rate generator driving the receiver and transmitter is shut down. This stops all SCI activity. Both the receiver and the transmitter are unable to operate.

If the STOP instruction is executed during a transmitter transfer, that transfer is halted. When STOP mode is exited as a result of an external interrupt, that particular transmission resumes.

If the receiver is receiving data when the STOP instruction is executed, received data sampling is stopped (baud generator stops) and the rest of the data is lost.

Warning: For the above reasons, all SCI transactions should be in the idle state when the STOP instruction is executed.

7.14 SCI during WAIT mode

The SCI system is not affected by WAIT mode and continues normal operation. Any valid SCI interrupt will wake-up the system. If required, the SCI system can be disabled prior to entering WAIT mode by writing a zero to the transmitter and receiver enable bits in the serial communication control register 2 at \$000F. This action will result in a reduction of power consumption during WAIT mode.

THIS PAGE LEFT BLANK INTENTIONALLY

8

PULSE LENGTH D/A CONVERTERS

The pulse length D/A converter (PLM) system works in conjunction with the timer to execute two 8-bit D/A conversions, with a choice of two repetition rates. (See [Figure 8-1.](#))

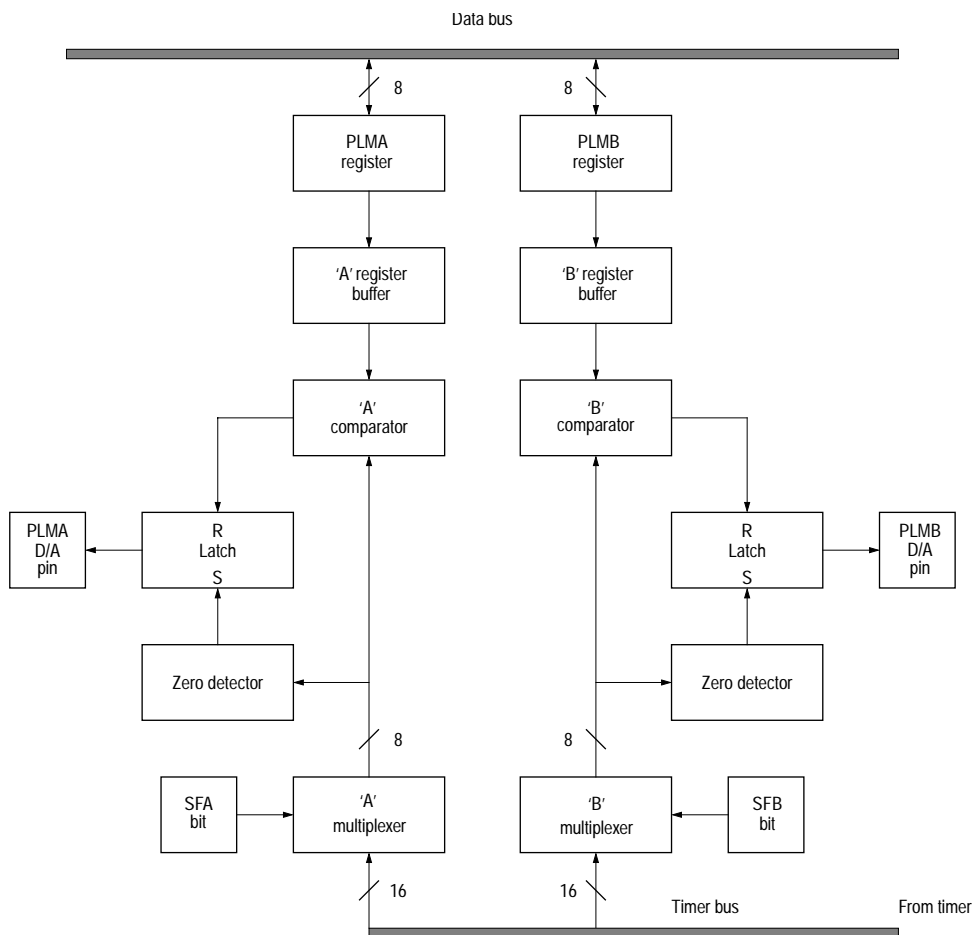

Figure 8-1 PLM system block diagram

The D/A converter has two data registers associated with it, PLMA and PLMB.

	Address	bit 7	bit 6	bit 5	bit 4	bit 3	bit 2	bit 1	bit 0	State on reset
Pulse length modulation A (PLMA)	\$000A									0000 0000
Pulse length modulation B (PLMB)	\$000B									0000 0000

This is a dual 8-bit resolution D/A converter associated with two output pins (PLMA and PLMB). The outputs are pulse length modulated signals whose duty cycle ratio may be modified. These signals can be used directly as PLMs, or the filtered average may be used as general purpose analog outputs.

The longest repetition period is 4096 times the programmable timer clock period (CPU clock multiplied by four), and the shortest repetition period is 256 times the programmable timer clock period (the repetition rate frequencies for a 4 MHz crystal are 122 Hz and 1953 Hz respectively). Registers PLMA (\$0A) and PLMB (\$0B) are associated with the pulse length values of the two counters. A value of \$00 loaded into these registers results in a continuously low output on the corresponding D/A output pin. A value of \$80 results in a 50% duty cycle output, and so on, to the maximum value \$FF corresponding to an output which is at '1' for 255/256 of the cycle. When the MCU makes a write to register PLMA or PLMB the new value will only be picked up by the D/A converters at the end of a complete cycle of conversion. This results in a monotonic change of the DC component at the output without overshoots or vicious starts (a vicious start is an output which gives totally erroneous PLM during the period immediately following an update of the PLM D/A registers). This feature is achieved by double buffering of the PLM D/A registers. Examples of PWM output waveforms are shown in [Figure 8-2](#).

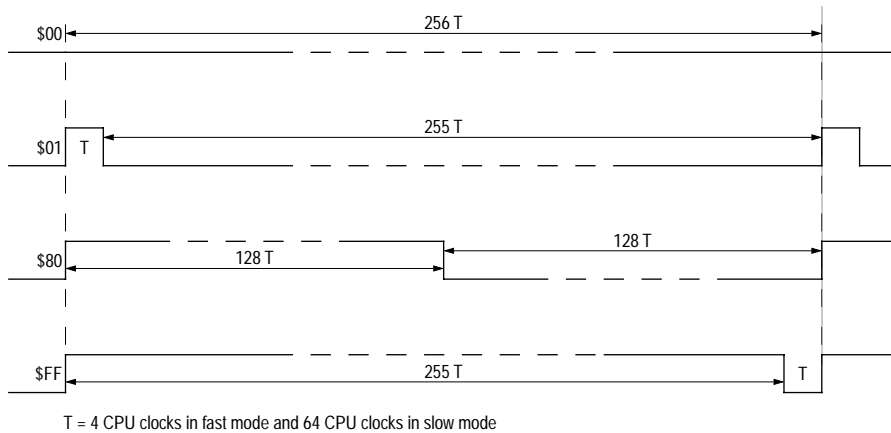

Figure 8-2 PLM output waveform examples

Note: Since the PLM system uses the timer counter, PLM results will be affected while resetting the timer counter. Both D/A registers are reset to \$00 during power-on or external reset. WAIT mode does not affect the output waveform of the D/A converters.

8.1 Miscellaneous register

	Address	bit 7	bit 6	bit 5	bit 4	bit 3	bit 2	bit 1	bit 0	State on reset
Miscellaneous	\$000C	POR	INTP	INTN	INTE	SFA	SFB	SM	WDOG	u001 000u

SFA — Slow or fast mode selection for PLMA

This bit allows the user to select the slow or fast mode of the PLMA pulse length modulation output.

1 (set) – Slow mode PLMA (4096 x timer clock period).

0 (clear) – Fast mode PLMA (256 x timer clock period).

SFB — Slow or fast mode selection for PLMB

This bit allows the user to select the slow or fast mode of the PLMB pulse length modulation output.

1 (set) – Slow mode PLMB (4096 x timer clock period).

0 (clear) – Fast mode PLMB (256 x timer clock period).

The highest speed of the PLM system corresponds to the frequency of the TOF bit being set, multiplied by 256. The lowest speed of the PLM system corresponds to the frequency of the TOF bit being set, multiplied by 16. Because the SFA bit and SFB bit are not double buffered, it is mandatory to set them to the desired values before writing to the PLM registers; not doing so could temporarily give incorrect values at the PLM outputs.

SM — Slow mode

1 (set) – The system runs at a bus speed 16 times lower than normal ($f_{OSC}/32$). SLOW mode affects all sections of the device, including SCI, A/D and timer.

0 (clear) – The system runs at normal bus speed ($f_{OSC}/2$).

The SM bit is cleared by external or power-on reset. The SM bit is automatically cleared when entering STOP mode.

Note: The bits that are shown shaded in the above representation are explained individually in the relevant sections of this manual. The complete register plus an explanation of each bit can be found in [Section 3.8](#).

8.2 PLM clock selection

The slow/fast mode of the PLM D/A converters is selected by bits 1, 2, and 3 of the miscellaneous register at address \$000C (SFA bit for PLMA and SFB bit for PLMB). The slow/fast mode has no effect on the D/A converters' 8-bit resolution (see [Figure 8-3](#)).

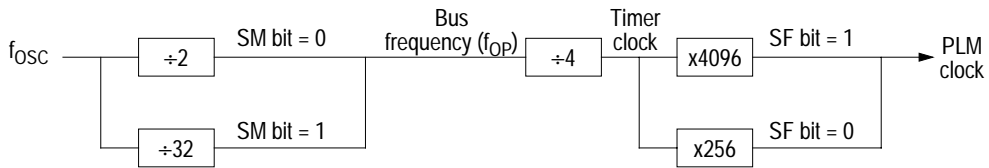

Figure 8-3 PLM clock selection

8.3 PLM during STOP mode

On entering STOP mode, the PLM outputs remain at their particular level. When STOP mode is exited by an interrupt, the PLM systems resume regular operation. If STOP mode is exited by power-on or external reset the registers values are forced to \$00.

8.4 PLM during WAIT mode

The PLM system is not affected by WAIT mode and continues normal operation.

9

ANALOG TO DIGITAL CONVERTER

The analog to digital converter system consists of a single 8-bit successive approximation converter and a sixteen channel multiplexer. Eight of the channels are connected to the PD0/AN0 – PD7/AN7 pins of the MC68HC05X16 and the other eight channels are dedicated to internal reference points for test functions. The channel input pins do not have any internal output driver circuitry connected to them because such circuitry would load the analog input signals due to output buffer leakage current. There is one 8-bit result data register (address \$08) and one 8-bit status/control register (address \$09).

The A/D converter is ratiometric and two dedicated pins, VRH and VRL, are used to supply the reference voltage levels for all analog inputs. These pins are used in preference to the system power supply lines because any voltage drops in the bonding wires of the heavily loaded supply pins could degrade the accuracy of the A/D conversion. An input voltage equal to or greater than V_{RH} converts to \$FF (full scale) with no overflow indication and an input voltage equal to V_{RL} converts to \$00.

The A/D converter can operate from either the bus clock or an internal RC type oscillator. The internal RC type oscillator is activated by the ADRC bit in the A/D status/control register (ADSTAT) and can be used to give a sufficiently high clock rate to the A/D converter when the bus speed is too low to provide accurate results. When the A/D converter is not being used it can be disconnected, by clearing the ADON bit in the ADSTAT register, in order to save power (see [Section 9.2.3](#)).

For further information on A/D converter operation please refer to the M68HC11 Reference Manual — M68HC11RM/AD.

9.1 A/D converter operation

The A/D converter consists of an analog multiplexer, an 8-bit digital to analog converter capacitor array, a comparator and a successive approximation register (SAR) (see [Figure 9-1](#)).

There are eleven options that can be selected by the multiplexer; AN0–AN7, VRH, $(VRH+VRL)/2$ or VRL. Selection is done via the CHx bits in the ADSTAT register (see [Section 9.2.3](#)). AN0–AN7 are the only input points for A/D conversion operations; the others are reference points that can be used for test purposes.

The A/D reference input (AN0–AN7) is applied to a precision internal D/A converter. Control logic drives this D/A converter and the analog output is successively compared with the analog input sampled at the beginning of the conversion. The conversion is monotonic with no missing codes.

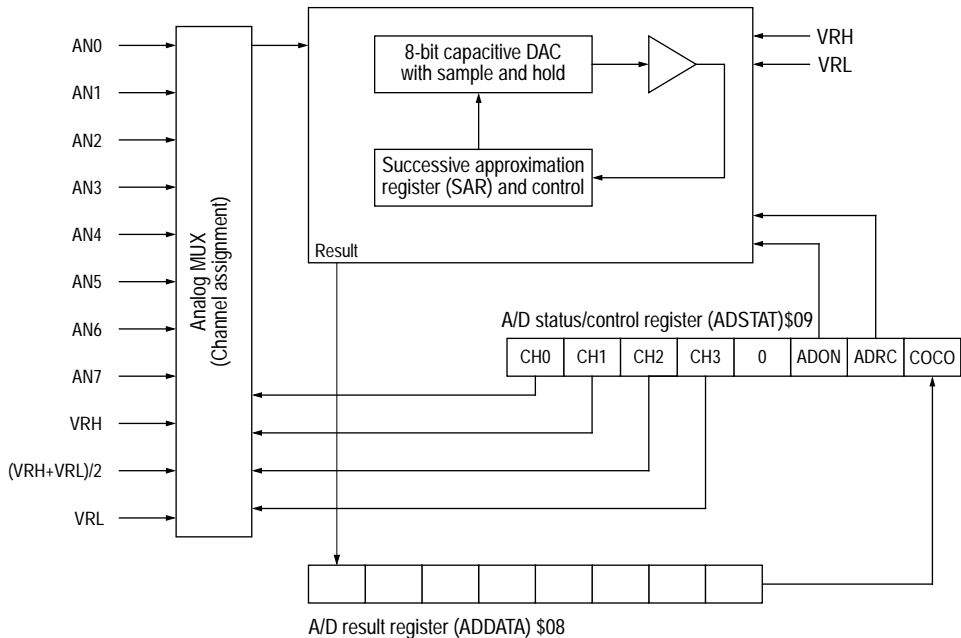

Figure 9-1 A/D converter block diagram

The result of each successive comparison is stored in the SAR and, when the conversion is complete, the contents of the SAR are transferred to the read-only result data register (\$08), and the conversion complete flag, COCO, is set in the A/D status/control register (\$09).

Warning: Any write to the A/D status/control register will abort the current conversion, reset the conversion complete flag and start a new conversion on the selected channel.

At power-on or external reset, both the ADRC and ADON bits are cleared; thus the A/D is disabled.

9.2 A/D registers

9.2.1 Port D data register (PORTD)

	Address	bit 7	bit 6	bit 5	bit 4	bit 3	bit 2	bit 1	bit 0	State on reset
Port D data (PORTD)	\$0003	PD7	PD6	PD5	PD4	PD3	PD2	PD1	PD0	Undefined

Port D is an input-only port which routes the eight analog inputs to the A/D converter. When the A/D converter is disabled, the pins are configured as standard input-only port pins, which can be read via the port D data register.

Note: When the A/D function is enabled, pins PD0–PD7 will act as analog inputs. Using a pin or pins as A/D inputs does not affect the ability to read port D as static inputs; however, reading port D during an A/D conversion sequence may inject noise on the analog inputs and result in reduced accuracy of the A/D result.

Performing a digital read of port D with levels other than V_{DD} or V_{SS} on the pins will result in greater power dissipation during the read cycle, and may give unpredictable results on the corresponding port D pins.

9.2.2 A/D result data register (ADDATA)

	Address	bit 7	bit 6	bit 5	bit 4	bit 3	bit 2	bit 1	bit 0	State on reset
A/D data (ADDATA)	\$0008									0000 0000

ADDATA is a read-only register which is used to store the results of A/D conversions. Each result is loaded into the register from the SAR and the conversion complete flag, COCO, in the ADSTAT register is set.

9.2.3 A/D status/control register (ADSTAT)

	Address	bit 7	bit 6	bit 5	bit 4	bit 3	bit 2	bit 1	bit 0	State on reset
A/D status/control (ADSTAT)	\$0009	COCO	ADRC	ADON	0	CH3	CH2	CH1	CH0	0000 0000

COCO — Conversion complete flag

- 1 (set) – COCO is set each time a conversion is complete, allowing the new result to be read from the A/D result data register (\$08). The converter then starts a new conversion.
- 0 (clear) – COCO is cleared by reading the result data register or writing to the status/control register.

Reset clears the COCO flag.

ADRC — A/D RC oscillator control

The ADRC bit allows the user to control the A/D RC oscillator, which is used to provide a sufficiently high clock rate to the A/D to ensure accuracy when the chip is running at low speeds.

- 1 (set) – When the ADRC bit is set, the A/D RC oscillator is turned on and, if ADON is set, the A/D runs from the RC oscillator clock. See [Table 9-1](#).
- 0 (clear) – When the ADRC bit is cleared, the A/D RC oscillator is turned-off and, if ADON is set, the A/D runs from the CPU clock.

When the A/D RC oscillator is turned on, it takes a time t_{ADRC} to stabilize (see [Table 12-3](#)). During this time A/D conversion results may be inaccurate.

Note: If the MCU bus clock falls below 1 MHz, the A/D RC oscillator should be switched on.

Power-on or external reset clears the ADRC bit.

Table 9-1 A/D clock selection

ADRC	ADON	RC oscillator	A/D converter	Comments
0	0	OFF	OFF	A/D switched off.
0	1	OFF	ON	A/D using CPU clock.
1	0	ON	OFF	Allows the RC oscillator to stabilize.
1	1	ON	ON	A/D using RC oscillator clock.

ADON — A/D converter on

The ADON bit allows the user to enable/disable the A/D converter.

1 (set) — A/D converter is switched on.

0 (clear) — A/D converter is switched off.

When the A/D converter is switched on, it takes a time t_{ADON} for the current sources to stabilize (see [Table 12-3](#)). During this time A/D conversion results may be inaccurate.

Power-on or external reset will clear the ADON bit, thus disabling the A/D converter.

CH3–CH0 — A/D channels 3, 2, 1 and 0

The CH3–CH0 bits allow the user to determine which channel of the A/D converter multiplexer is selected. See [Table 9-2](#) for channel selection.

Reset clears the CH0–CH3 bits.

Table 9-2 A/D channel assignment

CH3	CH2	CH1	CH0	Channel selected
0	0	0	0	AN0
0	0	0	1	AN1
0	0	1	0	AN2
0	0	1	1	AN3
0	1	0	0	AN4
0	1	0	1	AN5
0	1	1	0	AN6
0	1	1	1	AN7
1	0	0	0	VRH pin (high)
1	0	0	1	(VRH + VRL) / 2
1	0	1	0	VRL pin (low)
1	0	1	1	VRL pin (low)
1	1	0	0	VRL pin (low)
1	1	0	1	VRL pin (low)
1	1	1	0	VRL pin (low)
1	1	1	1	VRL pin (low)

9.3 A/D converter during STOP mode

When the MCU enters STOP mode with the A/D converter turned on, the A/D clocks are stopped and the A/D converter is disabled for the duration of STOP mode, including the 4064 cycles start-up time. If the A/D RC oscillator is in operation it will also be disabled.

9.4 A/D converter during WAIT mode

The A/D converter is not affected by WAIT mode and continues normal operation.

In order to reduce power consumption the A/D converter can be disconnected, under software control using the ADON bit and the ADRC bit in the A/D status/control register at \$0009, before entering WAIT mode.

9.5 Port D analog input

The external analog voltage value to be processed by the A/D converter is sampled on an internal capacitor through a resistive path, provided by input-selection switches and a sampling aperture time switch, as shown in Figure 9-2. Sampling time is limited to 12 bus clock cycles. After sampling, the analog value is stored on the capacitor and held until the end of conversion. During this hold time, the analog input is disconnected from the internal A/D system and the external voltage source sees a high impedance input.

The equivalent analog input during sampling is an RC low-pass filter with a minimum resistance of 50 k Ω and a capacitance of at least 10pF. It should be noted that these are typical values measured at room temperature.

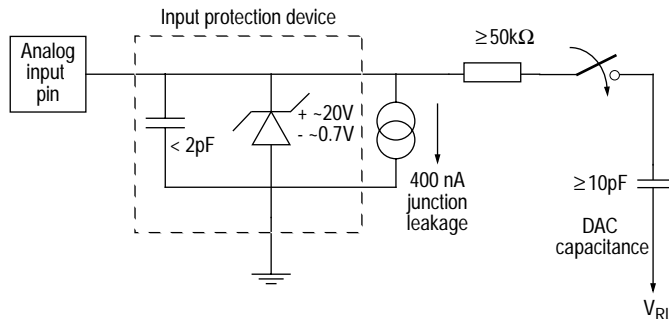

Note: The analog switch is closed during the 12 cycle sample time only.

Figure 9-2 Electrical model of an A/D input pin

10

RESETS AND INTERRUPTS

10.1 Resets

The MC68HC05X32 can be reset in three ways: by the initial power-on reset function, by an active low input to the $\overline{\text{RESET}}$ pin or by a computer operating properly (COP) watchdog reset. Any of these resets will cause the program to go to its starting address, specified by the contents of memory locations \$3FFE and \$3FFF, and cause the interrupt mask bit in the condition code register to be set.

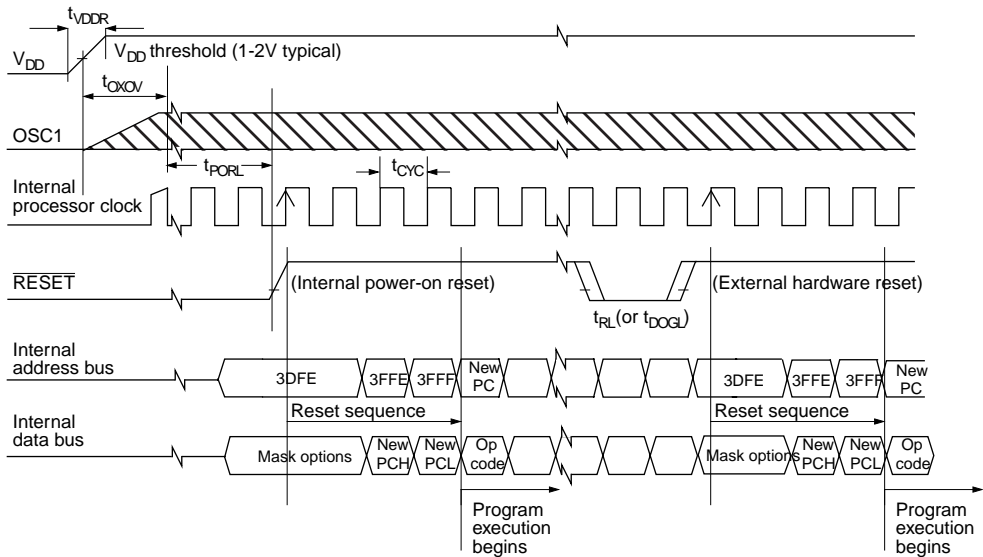

Figure 10-1 Reset timing diagram

10.1.1 Power-on reset

A power-on reset occurs when a positive transition is detected on VDD. The power-on reset function is strictly for power turn-on conditions and should not be used to detect drops in the power supply voltage. The power-on circuitry provides a stabilization delay (t_{PORL}) from when the oscillator becomes active. If the external \overline{RESET} pin is low at the end of this delay then the processor remains in the reset state until \overline{RESET} goes high. The user must ensure that the voltage on VDD has risen to a point where the MCU can operate properly by the time t_{PORL} has elapsed. If there is doubt, the external \overline{RESET} pin should remain low until the voltage on VDD has reached the specified minimum operating voltage. This may be accomplished by connecting an external RC circuit to this pin to generate a power-on reset (POR). In this case, the time constant must be great enough to allow the oscillator circuit to stabilize.

During power-on reset, the \overline{RESET} pin is driven low during a t_{PORL} delay start-up sequence. t_{PORL} is defined by a user specified mask option to be either 16 cycles or 4064 cycles (see [Section 1.2](#)).

A software distinction between a power-on reset and an external reset can be made using the POR bit in the miscellaneous register (see [Section 10.1.2](#)).

10.1.2 Miscellaneous register

	Address	bit 7	bit 6	bit 5	bit 4	bit 3	bit 2	bit 1	bit 0	State on reset
Miscellaneous	\$000C	POR ⁽¹⁾	INTP	INTN	INTE	SFA	SFB	SM	WDOG ⁽²⁾	u001 000u

(1) The POR bit is set each time there is a power-on reset.

(2) The state of the WDOG bit after reset is dependent on the mask option selected; 1=watchdog enabled, 0=watchdog disabled.

10

POR — Power-on reset bit

This bit is set each time the device is powered on. Therefore, the state of the POR bit allows the user to make a software distinction between a power-on and an external reset. This bit cannot be set by software and is cleared by writing it to zero.

1 (set) – A power-on reset has occurred.

0 (clear) – No power-on reset has occurred.

Note: The bits shown shaded in the above representation are explained individually in the relevant sections of this manual. The complete register plus an explanation of each bit can be found in [Section 3.8](#).

10.1.3 $\overline{\text{RESET}}$ pin

When the oscillator is running in a stable condition, the MCU is reset when a logic zero is applied to the $\overline{\text{RESET}}$ input for a minimum period of 1.5 machine cycles (t_{CYC}). An internal Schmitt Trigger is used to improve noise immunity on this pin. When the $\overline{\text{RESET}}$ pin goes high, the MCU will resume operation on the following cycle. When a reset condition occurs internally, i.e. from POR or the COP watchdog, the $\overline{\text{RESET}}$ pin provides an active-low open drain output signal which may be used to reset external hardware. Current limitation to protect the pull-down device is provided in case an RC type external reset circuit is used.

Note: If an external RC is connected to $\overline{\text{RESET}}$, turning on the $\overline{\text{RESET}}$ pull-down transistor may discharge the capacitor. The device will then remain in reset until the capacitor has recharged, after turning off the pull-down device.

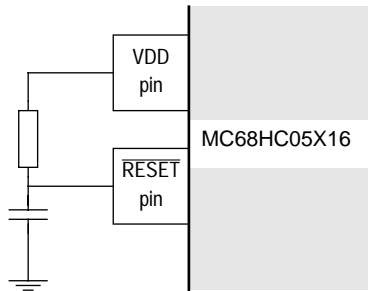

Figure 10-2 $\overline{\text{RESET}}$ external RC pull-down

10.1.4 Computer operating properly (COP) watchdog reset

The watchdog counter system consists of a divide-by-7 counter, preceded by a fixed divide-by-4 and a fixed divide-by-256 prescaler, plus control logic as shown in Figure 10-3. The divide-by-7 counter can be reset by software.

Note: The input to the watchdog system is derived from the carry output of bit 7 of the free running timer counter. Therefore, a reset of the timer may affect the period of the watchdog timeout.

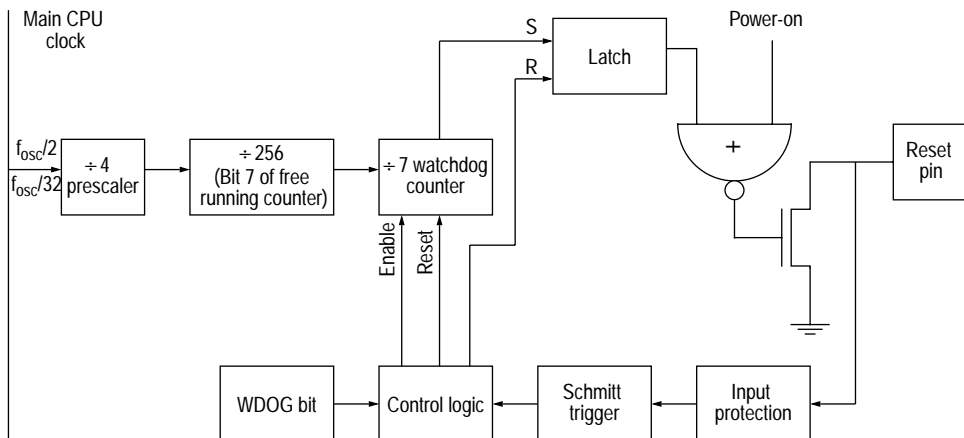

Figure 10-3 Watchdog system block diagram

The watchdog system can be automatically enabled, following power-on or external reset, via a mask option (see [Section 1.2](#)), or it can be enabled by software by writing a '1' to the WDOG bit in the miscellaneous register at \$000C (see [Section 10.1.2](#)). Once enabled, the watchdog system cannot be disabled by software (writing a 'zero' to the WDOG bit has no effect at any time). In addition, the WDOG bit acts as a reset mechanism for the watchdog counter. Writing a '1' to this bit clears the counter to its initial value and prevents a watchdog timeout.

WDOG — Watchdog enable/disable

The WDOG bit can be used to enable the watchdog timer previously disabled by a mask option. Following a watchdog reset the state of the WDOG bit is as defined by the mask option specified.

- 1 (set) – Watchdog enabled and counter cleared.
- 0 (clear) – The watchdog cannot be disabled by software; writing a zero to this bit has no effect.

The divide-by-7 watchdog counter will generate a main reset of the chip when it reaches its final state; seven clocks are necessary to bring the watchdog counter from its clear state to its final state. This reset appears after time t_{DOG} since the last clear or since the enable of the watchdog counter system. The watchdog counter, therefore, has to be cleared periodically, by software, with a period less than t_{DOG} .

The reset generated by the watchdog system is apparent at the $\overline{\text{RESET}}$ pin (see [Figure 10-3](#)). The $\overline{\text{RESET}}$ pin level is re-entered in the control logic, and when it has been maintained at level 'zero' for a minimum of t_{DOGL} , the $\overline{\text{RESET}}$ pin is released.

10.1.4.1 COP watchdog during STOP mode

The STOP instruction is inhibited when the watchdog system is enabled. If a STOP instruction is executed while the watchdog system is enabled, then a watchdog reset will occur as if there were a watchdog timeout. In the case of a watchdog reset due to a STOP instruction, the oscillator will not be affected, thus there will be no t_{PORL} cycles start-up delay. On start-up, the watchdog will be configured according to the user specified mask option.

10.1.4.2 COP watchdog during WAIT mode

The state of the watchdog during WAIT mode is selected via a mask option (see [Section 1.2](#)) to be one of the options below:

Watchdog enabled — the watchdog counter will continue to operate during WAIT mode and a reset will occur after time t_{DOG} .

Watchdog disabled — on entering WAIT mode, the watchdog counter system is reset and disabled. On exiting WAIT mode the counter resumes normal operation.

10.1.5 Functions affected by reset

When processing stops within the MCU for any reason, i.e. power-on reset, external reset or the execution of a STOP or WAIT instruction, various internal functions of the MCU are affected. [Table 10-1](#) shows the resulting action of any type of system reset, but not necessarily in the order in which they occur.

Note: Reset action on individual MCAN registers is described in [Section 5](#) and is also summarised in [Table 3-2](#).

Table 10-1 Effect of RESET, POR, STOP and WAIT

Function/effect	RESET	POR	WAIT	STOP
Timer prescaler cleared	x	x	–	–
Timer counter set to \$FFFC	x	x	–	–
All timer enable bits cleared (disable)	x	x	–	–
Data direction registers cleared (inputs)	x	x	–	–
Stack pointer set to \$00FF	x	x	–	–
Internal address bus forced to restart	x	x	–	–
Vector \$3FFE, \$3FFF	x	x	–	–
Interrupt mask bit (I-bit CCR) set	x	x	–	–
Interrupt mask bit (I-bit CCR) cleared	–	–	x	x
Interrupt enable bit (INTE) set	x	x	–	–
POR bit in miscellaneous register set	–	x	–	–
STOP latch reset	x	x	–	–
IRQ latch reset	x	x	–	–
WAIT latch reset	x	x	–	–
SCI disabled	x	x	–	–
SCI status bits cleared (except TDRE and TC)	x	x	–	–
SCI interrupt enable bits cleared	x	x	–	–
SCI status bits TDRE and TC set	x	x	–	–
Oscillator disabled for 4064 cycles	–	x	–	x
Timer clock cleared	–	x	–	x
SCI clock cleared	–	x	–	x
A/D disabled	x	x	–	x
SM bit in the miscellaneous register cleared	x	x	–	x
Watchdog counter reset	x	x	x	x
WDOG bit in the miscellaneous register reset	x	x	–	x
EEPROM control bits set or cleared (as per Section 3.5.1)	x	x	–	x

x = Described action takes place

– = Described action does not take place

10.2 Interrupts

The MCU can be interrupted by five different sources: three maskable hardware interrupts, one non maskable software interrupt and one maskable MCAN interrupt:

- External signal on the $\overline{\text{TRQ}}$ pin, WOI on port B pins or NWOI pin
- Serial communications interface (SCI)
- Programmable timer
- Software interrupt instruction (SWI)
- MCAN interrupt (CIRQ)

Interrupts cause the processor to save the register contents on the stack and to set the interrupt mask (I-bit) to prevent additional interrupts. The RTI instruction (return from interrupt) causes the register contents to be recovered from the stack and normal processing to resume. While executing the RTI instruction, the value of the I-bit is replaced by the corresponding I-bit stored on the stack.

Unlike reset, hardware interrupts do not cause the current instruction execution to be halted, but are considered pending until the current instruction is complete. The current instruction is the one already fetched and being operated on. When the current instruction is complete, the processor checks all pending hardware interrupts. If interrupts are not masked (I-bit clear) and the corresponding interrupt enable bit is set, the processor proceeds with interrupt processing; otherwise, the next instruction is fetched and executed.

Note: Power-on and external reset clear all interrupt enable bits to prevent interrupts during the reset sequence, but set the INTE bit (see [Section 3.8](#)).

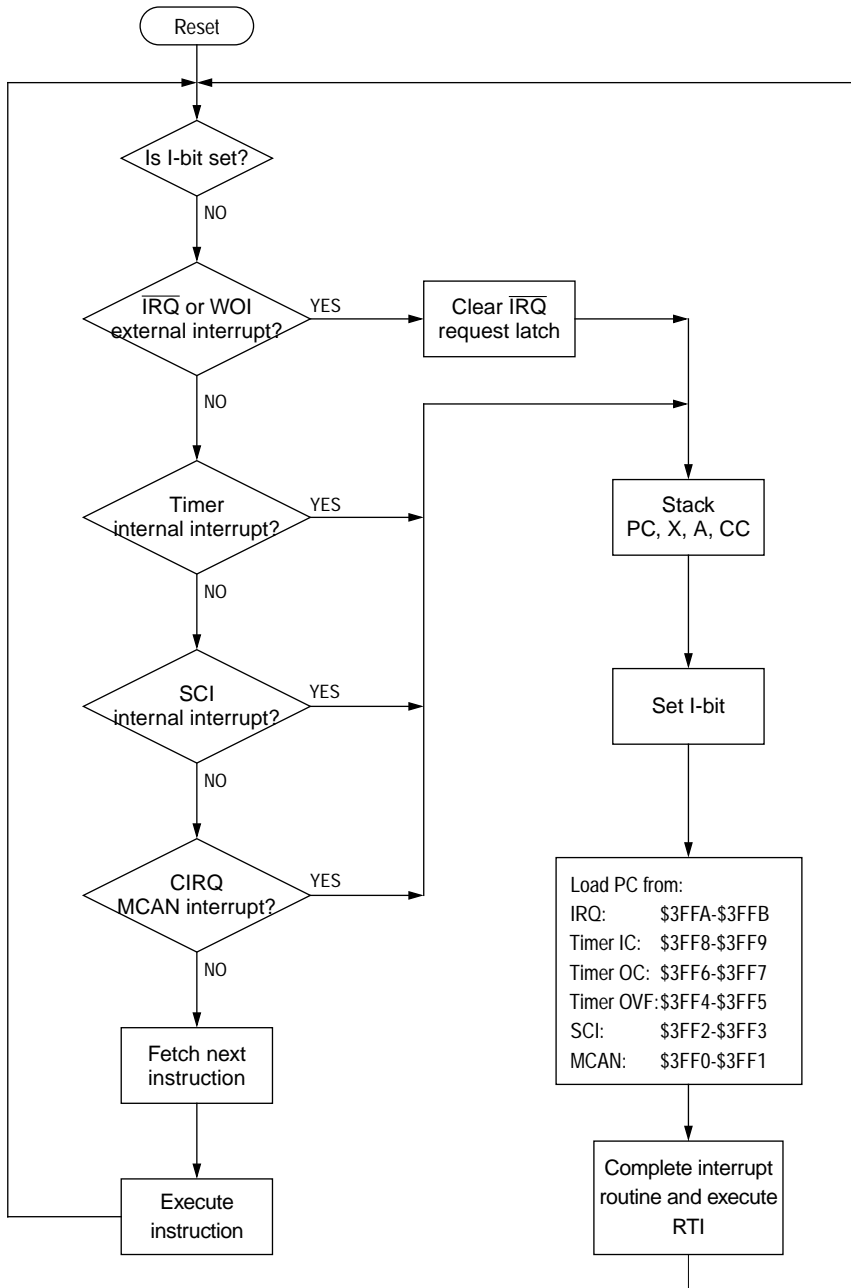

Figure 10-4 Interrupt flow chart

10.2.1 Interrupt priorities

Each potential interrupt source is assigned a priority level, which means that if more than one interrupt is pending at the same time, the processor will service the one with the highest priority first. For example, if both an external interrupt and a timer interrupt are pending after an instruction execution, the external interrupt is serviced first.

Table 10-2 shows the relative priority of all the possible interrupt sources. Figure 10-4 shows the interrupt processing flow.

Table 10-2 Interrupt priorities

Source	Register	Flags	Vector address	Priority
Reset	—	—	\$3FFE, \$3FFF	 highest
Software interrupt (SWI)	—	—	\$3FFC, \$3FFD	
External interrupt (IRQ) or WOI	—	—	\$3FFA, \$3FFB	
Timer input captures	TSR	ICF1, ICF2	\$3FF8, \$3FF9	
Timer output compares	TSR	OCF1, OCF2	\$3FF6, \$3FF7	
Timer overflow	TSR	TOF	\$3FF4, \$3FF5	
Serial communications interface (SCI)	SCSR	TDRE, TC, OR, RDRF, IDLE	\$3FF2, \$3FF3	
MCAN	CINT	WIF, OIF, EIF, TIF, RIF	\$3FF0, \$3FF1	

10.2.2 Nonmaskable software interrupt (SWI)

The software interrupt (SWI) is an executable instruction and a nonmaskable interrupt: it is executed regardless of the state of the I-bit in the CCR. If the I-bit is zero (interrupts enabled), SWI is executed after interrupts that were pending when the SWI was fetched, but before interrupts generated after the SWI was fetched. The SWI interrupt service routine address is specified by the contents of memory locations \$3FFC and \$3FFD.

10

10.2.3 Maskable hardware interrupts

If the interrupt mask bit in the CCR is set, all maskable interrupts (internal and external) are masked. Clearing the I-bit allows interrupt processing to occur.

Note: The internal interrupt latch is cleared in the first part of the interrupt service routine; therefore, one external interrupt pulse could be latched and serviced as soon as the I-bit is cleared.

10.2.3.1 Miscellaneous register

	Address	bit 7	bit 6	bit 5	bit 4	bit 3	bit 2	bit 1	bit 0	State on reset
Miscellaneous	\$000C	POR	INTP	INTN	INTE	SFA	SFB	SM	WDOG	u001 000u

Note: The bits shown shaded in the above representation are explained individually in the relevant sections of this manual. The complete register plus an explanation of each bit can be found in [Section 3.8](#).

INTP, INTN — External interrupt sensitivity options

These two bits allow the user to select which edge the \overline{IRQ} and WOI pins are sensitive to as shown in [Table 10-3](#). Both bits can be written to only while the I-bit is set, and are cleared by power-on or external reset. Therefore the device is initialised with negative edge and low level sensitivity.

Table 10-3 \overline{IRQ} and WOI sensitivity

INTP	INTN	\overline{IRQ} sensitivity	WOI interrupt sensitivity
0	0	Negative edge and low level sensitive	Positive edge and high level sensitive
0	1	Negative edge only	Positive edge only
1	0	Positive edge only	Negative edge only
1	1	Positive and negative edge sensitive	Positive and negative edge sensitive

Interrupt sensitivity options selected by INTP and INTN of the miscellaneous register apply to external interrupt signal, EI. EI is an OR function of all enabled WOI pins (port B and NWOI) and of the inverted value of the \overline{IRQ} pin. When one WOI pin is high, it masks any subsequent edge or level on any other EI pin (\overline{IRQ} , port B or NWOI).

INTE — External interrupt enable

- 1 (set) – External interrupt (\overline{IRQ}) and wired-OR interrupt (WOI) enabled.
- 0 (clear) – External interrupt (\overline{IRQ}) and wired-OR interrupt (WOI) disabled.

The INTE bit can be written to only while the I-bit is set, and is set by power-on or external reset, thus enabling the external interrupt function.

[Table 10-3](#) describes the various triggering options available for the \overline{IRQ} and WOI pins, however it is important to re-emphasize here that in order to avoid any conflict and spurious interrupt, it is possible to change the external interrupt options only while the I-bit is set. Any attempt to change the external interrupt option while the I-bit is clear will be unsuccessful. If an external interrupt is pending, it will automatically be cleared when selecting a different interrupt option.

Note: If the external interrupt function is disabled by the INTE bit and an external interrupt is sensed by the edge detector circuitry, then the interrupt request is latched and the interrupt stays pending until the INTE bit is set. The internal latch of the external interrupt is cleared in the first part of the service routine (except for the low level interrupt which is not latched); therefore, only one external interrupt pulse can be latched during t_{LIL} and serviced as soon as the I-bit is cleared.

10.2.3.2 External interrupts

\overline{IRQ} interrupt

If the interrupt mask in the condition code register has been cleared and the interrupt enable bit (INTE) is set and the signal on the external interrupt pin (\overline{IRQ}) satisfies the condition selected by the option control bits (INTP and INTN), then the external interrupt is recognized. INTE, INTP and INTN are all bits contained in the miscellaneous register at \$000C. When the interrupt is recognized, the current state of the CPU is pushed onto the stack and the I-bit is set. This masks further interrupts until the present one is serviced. The external interrupt service routine address is specified by the content of memory locations \$3FFA and \$3FFB.

Wired-OR interrupt (WOI)

An external WOI capability is provided on all port B I/O pins when they are programmed as inputs, and on the NWOI pin. A WOI is activated only if WOIE in the EEPROM control register is set and if wired-OR interrupts have been chosen as an option on the device (see [Section 1.2](#)). If wired-OR interrupts are enabled on a given input pin (NWOI pin or port B pins; refer to [Section 2.3.19](#) and [Section 4.2](#)), an external interrupt is requested when this pin is pulled high. The request is serviced by the interrupt routine whose start address is contained in memory locations \$3FFA and \$3FFB. External and power-on reset clear the WOIE bit. A WOI interrupt will cause the MCU to exit STOP mode.

The interrupt enable bit (INTE) in the miscellaneous register enables both wired-OR interrupts and the \overline{IRQ} interrupt. \overline{IRQ} and WOI are internally OR-ed before interrupt sensitivity selection (see [Section 10.2.3.1](#)).

10.2.3.3 MCAN interrupt (CIRQ)

Several sources can trigger a CIRQ. The MCAN interrupt register at \$0023 is used to identify the source. Each CIRQ source can be individually enabled (except the wake-up interrupt, which is always enabled) by different bits of the MCAN control register at \$0020.

The CIRQ sources are (also see [Section 5.3.4](#)):

Receive IRQ: this signals successful reception of a complete message.

Transmit IRQ: this signals successful transmission of a complete message.

Error IRQ: this is set when either the error status or bus status bits in the MCAN status register change state (see [Section 5.3.3](#)).

Data overrun: an incoming message on the bus cannot be received because both receive buffers are tied up.

Wake-up IRQ: this signals activity on the bus while the MCAN is in SLEEP mode. This is the only nonmaskable CIRQ.

CIRQ interrupts are serviced by the routine located at the address specified by the contents of \$3FF0 and \$3FF1.

10.2.3.4 Timer interrupts

There are five different timer interrupt flags (ICF1, ICF2, OCF1, OCF2 and TOF) that will cause a timer interrupt whenever they are set and enabled. These five interrupt flags are found in the five most significant bits of the timer status register (TSR) at location \$0013. ICF1 and ICF2 will vector to the service routine defined by \$3FF8–\$3FF9, OCF1 and OCF2 will vector to the service routine defined by \$3FF6–\$3FF7 and TOF will vector to the service routine defined by \$3FF4–\$3FF5 as shown in [Figure 6-1](#).

There are three corresponding enable bits; ICIE for ICF1 and ICF2, OCIE for OCF1 and OCF2, and TOIE for TOF. These enable bits are located in the timer control register (TCR) at address \$0012. See [Section 6.2.1](#) and [Section 6.2.2](#) for further information.

10.2.3.5 Serial communications interface (SCI) interrupts

There are five different interrupt flags (TDRE, TC, OR, RDRF and IDLE) that cause SCI interrupts whenever they are set and enabled. These five interrupt flags are found in the five most significant bits of the SCI status register (SCSR) at location \$0010.

There are four corresponding enable bits: TIE for TDRE, TCIE for TC, RIE for OR and RDRF, and ILIE for IDLE. These enable bits are located in the serial communications control register 2 (SCCR2) at address \$000F. See [Section 7.11.3](#) and [Section 7.11.4](#).

The SCI interrupt causes the program counter to vector to the address pointed to by memory locations \$3FF2 and \$3FF3 which contain the starting address of the interrupt service routine. Software in the SCI interrupt service routine must determine the priority and cause of the interrupt by examining the interrupt flags and the status bits located in the serial communications status register SCSR (address \$0010).

The general sequence for clearing an interrupt is a software sequence of accessing the serial communications status register while the flag is set followed by a read or write of an associated register. Refer to [Section 7](#) for a description of the SCI system and its interrupts.

10.2.4 Hardware controlled interrupt sequence

The following three functions: reset, STOP and WAIT, are not in the strictest sense interrupts. However, they are acted upon in a similar manner. Flowcharts for STOP and WAIT are shown in [Figure 2-4](#).

RESET: A reset condition causes the program to vector to its starting address, which is contained in memory locations \$3FFE (MSB) and \$3FFF (LSB). The I-bit in the condition code register is also set, to disable interrupts.

STOP: The STOP instruction puts the processor to 'sleep' and, if the MCAN module is already in SLEEP mode, it causes the oscillator to be turned off until an external, WOI or CIRQ interrupt occurs or the device is reset.

WAIT: The WAIT instruction causes all processor clocks to stop, but leaves the timer clocks running. This 'rest' state of the processor can be cleared by reset, an external or WOI interrupt, a timer interrupt or an SCI interrupt. There are no special WAIT vectors for these individual interrupts.

THIS PAGE LEFT BLANK INTENTIONALLY

11

CPU CORE AND INSTRUCTION SET

This section provides a description of the CPU core registers, the instruction set and the addressing modes of the MC68HC05X16.

11.1 Registers

The MCU contains five registers, as shown in the programming model of Figure 11-1. The interrupt stacking order is shown in Figure 11-2.

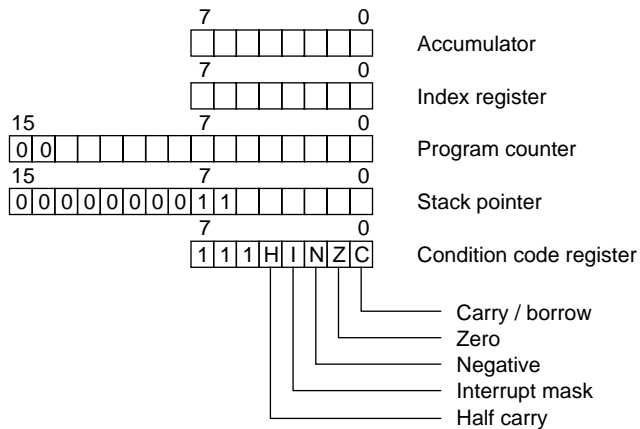

Figure 11-1 Programming model

11.1.1 Accumulator (A)

The accumulator is a general purpose 8-bit register used to hold operands and results of arithmetic calculations or data manipulations.

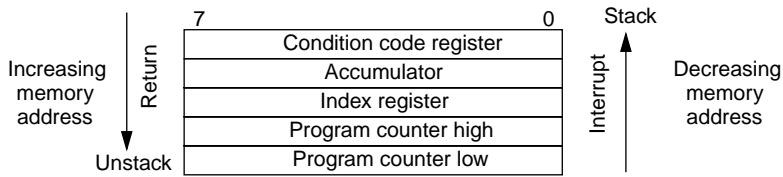

Figure 11-2 Stacking order

11.1.2 Index register (X)

The index register is an 8-bit register, which can contain the indexed addressing value used to create an effective address. The index register may also be used as a temporary storage area.

11.1.3 Program counter (PC)

The program counter is a 16-bit register, which contains the address of the next byte to be fetched. Although the M68HC05 CPU core can address 64K bytes of memory, the actual address range of the MC68HC05X32 is limited to 16K bytes. The two most significant bits of the program counter are therefore not used and are permanently set to zero.

11.1.4 Stack pointer (SP)

The stack pointer is a 16-bit register, which contains the address of the next free location on the stack. During an MCU reset or the reset stack pointer (RSP) instruction, the stack pointer is set to location \$00FF. The stack pointer is then decremented as data is pushed onto the stack and incremented as data is pulled from the stack.

When accessing memory, the ten most significant bits are permanently set to 0000000011. These ten bits are appended to the six least significant register bits to produce an address within the range of \$00C0 to \$00FF. Subroutines and interrupts may use up to 64 (decimal) locations. If 64 locations are exceeded, the stack pointer wraps around and overwrites the previously stored information. A subroutine call occupies two locations on the stack; an interrupt uses five locations.

11.1.5 Condition code register (CCR)

The CCR is a 5-bit register in which four bits are used to indicate the results of the instruction just executed, and the fifth bit indicates whether interrupts are masked. These bits can be individually tested by a program, and specific actions can be taken as a result of their state. Each bit is explained in the following paragraphs.

Half carry (H)

This bit is set during ADD and ADC operations to indicate that a carry occurred between bits 3 and 4.

Interrupt (I)

When this bit is set, all maskable interrupts are masked. If an interrupt occurs while this bit is set, the interrupt is latched and remains pending until the interrupt bit is cleared.

Negative (N)

When set, this bit indicates that the result of the last arithmetic, logical, or data manipulation was negative.

Zero (Z)

When set, this bit indicates that the result of the last arithmetic, logical, or data manipulation was zero.

Carry/borrow (C)

When set, this bit indicates that a carry or borrow out of the arithmetic logical unit (ALU) occurred during the last arithmetic operation. This bit is also affected during bit test and branch instructions and during shifts and rotates.

11.2 Instruction set

The MCU has a set of 62 basic instructions. They can be grouped into five different types as follows:

- Register/memory
- Read/modify/write
- Branch
- Bit manipulation
- Control

The following paragraphs briefly explain each type. All the instructions within a given type are presented in individual tables.

This MCU uses all the instructions available in the M146805 CMOS family plus one more: the unsigned multiply (MUL) instruction. This instruction allows unsigned multiplication of the contents of the accumulator (A) and the index register (X). The high-order product is then stored in the index register and the low-order product is stored in the accumulator. A detailed definition of the MUL instruction is shown in [Table 11-1](#).

11.2.1 Register/memory Instructions

Most of these instructions use two operands. The first operand is either the accumulator or the index register. The second operand is obtained from memory using one of the addressing modes. The jump unconditional (JMP) and jump to subroutine (JSR) instructions have no register operand. Refer to [Table 11-2](#) for a complete list of register/memory instructions.

11.2.2 Branch instructions

These instructions cause the program to branch if a particular condition is met; otherwise, no operation is performed. Branch instructions are two-byte instructions. Refer to [Table 11-3](#).

11.2.3 Bit manipulation instructions

The MCU can set or clear any writable bit that resides in the first 256 bytes of the memory space (page 0). All port data and data direction registers, timer and serial interface registers, control/status registers and a portion of the on-chip RAM reside in page 0. An additional feature allows the software to test and branch on the state of any bit within these locations. The bit set, bit clear, bit test and branch functions are all implemented with single instructions. For the test and branch instructions, the value of the bit tested is also placed in the carry bit of the condition code register. Refer to [Table 11-4](#).

11.2.4 Read/modify/write instructions

These instructions read a memory location or a register, modify or test its contents, and write the modified value back to memory or to the register. The test for negative or zero (TST) instruction is an exception to this sequence of reading, modifying and writing, since it does not modify the value. Refer to [Table 11-5](#) for a complete list of read/modify/write instructions.

11.2.5 Control instructions

These instructions are register reference instructions and are used to control processor operation during program execution. Refer to [Table 11-6](#) for a complete list of control instructions.

11.2.6 Tables

Tables for all the instruction types listed above follow. In addition there is a complete alphabetical listing of all the instructions (see [Table 11-7](#)), and an opcode map for the instruction set of the M68HC05 MCU family (see [Table 11-8](#)).

Table 11-1 MUL instruction

Operation	X:A ← X*A			
Description	Multiplies the eight bits in the index register by the eight bits in the accumulator and places the 16-bit result in the concatenated accumulator and index register.			
Condition codes	H : Cleared I : Not affected N : Not affected Z : Not affected C : Cleared			
Source	MUL			
Form	Addressing mode Inherent	Cycles 11	Bytes 1	Opcode \$42

Table 11-2 Register/memory instructions

Function	Mnemonic	Addressing modes																	
		Immediate			Direct			Extended			Indexed (no offset)			Indexed (8-bit offset)			Indexed (16-bit offset)		
		Opcode	# Bytes	# Cycles	Opcode	# Bytes	# Cycles	Opcode	# Bytes	# Cycles	Opcode	# Bytes	# Cycles	Opcode	# Bytes	# Cycles	Opcode	# Bytes	# Cycles
Load A from memory	LDA	A6	2	2	B6	2	3	C6	3	4	F6	1	3	E6	2	4	D6	3	5
Load X from memory	LDX	AE	2	2	BE	2	3	CE	3	4	FE	1	3	EE	2	4	DE	3	5
Store A in memory	STA				B7	2	4	C7	3	5	F7	1	4	E7	2	5	D7	3	6
Store X in memory	STX				BF	2	4	CF	3	5	FF	1	4	EF	2	5	DF	3	6
Add memory to A	ADD	AB	2	2	BB	2	3	CB	3	4	FB	1	3	EB	2	4	DB	3	5
Add memory and carry to A	ADC	A9	2	2	B9	2	3	C9	3	4	F9	1	3	E9	2	4	D9	3	5
Subtract memory	SUB	A0	2	2	B0	2	3	C0	3	4	F0	1	3	E0	2	4	D0	3	5
Subtract memory from A with borrow	SBC	A2	2	2	B2	2	3	C2	3	4	F2	1	3	E2	2	4	D2	3	5
AND memory with A	AND	A4	2	2	B4	2	3	C4	3	4	F4	1	3	E4	2	4	D4	3	5
OR memory with A	ORA	AA	2	2	BA	2	3	CA	3	4	FA	1	3	EA	2	4	DA	3	5
Exclusive OR memory with A	EOR	A8	2	2	B8	2	3	C8	3	4	F8	1	3	E8	2	4	D8	3	5
Arithmetic compare A with memory	CMP	A1	2	2	B1	2	3	C1	3	4	F1	1	3	E1	2	4	D1	3	5
Arithmetic compare X with memory	CPX	A3	2	2	B3	2	3	C3	3	4	F3	1	3	E3	2	4	D3	3	5
Bit test memory with A (logical compare)	BIT	A5	2	2	B5	2	3	C5	3	4	F5	1	3	E5	2	4	D5	3	5
Jump unconditional	JMP				BC	2	2	CC	3	3	FC	1	2	EC	2	3	DC	3	4
Jump to subroutine	JSR				BD	2	5	CD	3	6	FD	1	5	ED	2	6	DD	3	7

Table 11-3 Branch instructions

Function	Mnemonic	Relative addressing mode		
		Opcode	# Bytes	# Cycles
Branch always	BRA	20	2	3
Branch never	BRN	21	2	3
Branch if higher	BHI	22	2	3
Branch if lower or same	BLS	23	2	3
Branch if carry clear	BCC	24	2	3
(Branch if higher or same)	(BHS)	24	2	3
Branch if carry set	BCS	25	2	3
(Branch if lower)	(BLO)	25	2	3
Branch if not equal	BNE	26	2	3
Branch if equal	BEQ	27	2	3
Branch if half carry clear	BHCC	28	2	3
Branch if half carry set	BHCS	29	2	3
Branch if plus	BPL	2A	2	3
Branch if minus	BMI	2B	2	3
Branch if interrupt mask bit is clear	BMC	2C	2	3
Branch if interrupt mask bit is set	BMS	2D	2	3
Branch if interrupt line is low	BIL	2E	2	3
Branch if interrupt line is high	BIH	2F	2	3
Branch to subroutine	BSR	AD	2	6

Table 11-4 Bit manipulation instructions

Function	Mnemonic	Addressing modes					
		Bit set/clear			Bit test and branch		
		Opcode	# Bytes	# Cycles	Opcode	# Bytes	# Cycles
Branch if bit n is set	BRSET n (n=0-7)				2·n	3	5
Branch if bit n is clear	BRCLR n (n=0-7)				01+2·n	3	5
Set bit n	BSET n (n=0-7)	10+2·n	2	5			
Clear bit n	BCLR n (n=0-7)	11+2·n	2	5			

Table 11-5 Read/modify/write instructions

Function	Mnemonic	Addressing modes														
		Inherent (A)			Inherent (X)			Direct			Indexed (no offset)			Indexed (8-bit offset)		
		Opcode	# Bytes	# Cycles	Opcode	# Bytes	# Cycles	Opcode	# Bytes	# Cycles	Opcode	# Bytes	# Cycles	Opcode	# Bytes	# Cycles
Increment	INC	4C	1	3	5C	1	3	3C	2	5	7C	1	5	6C	2	6
Decrement	DEC	4A	1	3	5A	1	3	3A	2	5	7A	1	5	6A	2	6
Clear	CLR	4F	1	3	5F	1	3	3F	2	5	7F	1	5	6F	2	6
Complement	COM	43	1	3	53	1	3	33	2	5	73	1	5	63	2	6
Negate (two's complement)	NEG	40	1	3	50	1	3	30	2	5	70	1	5	60	2	6
Rotate left through carry	ROL	49	1	3	59	1	3	39	2	5	79	1	5	69	2	6
Rotate right through carry	ROR	46	1	3	56	1	3	36	2	5	76	1	5	66	2	6
Logical shift left	LSL	48	1	3	58	1	3	38	2	5	78	1	5	68	2	6
Logical shift right	LSR	44	1	3	54	1	3	34	2	5	74	1	5	64	2	6
Arithmetic shift right	ASR	47	1	3	57	1	3	37	2	5	77	1	5	67	2	6
Test for negative or zero	TST	4D	1	3	5D	1	3	3D	2	4	7D	1	4	6D	2	5
Multiply	MUL	42	1	11												
Set bit n	BSET n (n=0-7)	10+2•n	2	5												
Clear bit n	BCLR n (n=0-7)	11+2•n	2	5												

Table 11-6 Control instructions

Function	Mnemonic	Inherent addressing mode		
		Opcode	# Bytes	# Cycles
Transfer A to X	TAX	97	1	2
Transfer X to A	TXA	9F	1	2
Set carry bit	SEC	99	1	2
Clear carry bit	CLC	98	1	2
Set interrupt mask bit	SEI	9B	1	2
Clear interrupt mask bit	CLI	9A	1	2
Software interrupt	SWI	83	1	10
Return from subroutine	RTS	81	1	6
Return from interrupt	RTI	80	1	9
Reset stack pointer	RSP	9C	1	2
No-operation	NOP	9D	1	2
Stop	STOP	8E	1	2
Wait	WAIT	8F	1	2

Table 11-7 Instruction set

Mnemonic	Addressing modes										Condition codes				
	INH	IMM	DIR	EXT	REL	IX	IX1	IX2	BSC	BTB	H	I	N	Z	C
ADC											◇	•	◇	◇	◇
ADD											◇	•	◇	◇	◇
AND											•	•	◇	◇	•
ASL											•	•	◇	◇	◇
ASR											•	•	◇	◇	◇
BCC											•	•	•	•	•
BCLR											•	•	•	•	•
BCS											•	•	•	•	•
BEQ											•	•	•	•	•
BHCC											•	•	•	•	•
BHCS											•	•	•	•	•
BHI											•	•	•	•	•
BHS											•	•	•	•	•
BIH											•	•	•	•	•
BIL											•	•	•	•	•
BIT											•	•	◇	◇	•
BLO											•	•	•	•	•
BLS											•	•	•	•	•
BMC											•	•	•	•	•
BMI											•	•	•	•	•
BMS											•	•	•	•	•
BNE											•	•	•	•	•
BPL											•	•	•	•	•
BRA											•	•	•	•	•
BRN											•	•	•	•	•
BRCLR											•	•	•	•	◇
BRSET											•	•	•	•	◇
BSET											•	•	•	•	•
BSR											•	•	•	•	•
CLC											•	•	•	•	0
CLI											•	0	•	•	•
CLR											•	•	0	1	•
CMP											•	•	◇	◇	◇

Address mode abbreviations

BS	Bit set/clear	IMM	Immediate
C			
BTB	Bit test & branch	IX	Indexed (no offset)
DIR	Direct	IX1	Indexed, 1 byte offset
EXT	Extended	IX2	Indexed, 2 byte offset
			Not implemented

Condition code symbols

H	Half carry (from bit 3)	◇	Tested and set if true, cleared otherwise
I	Interrupt mask	•	Not affected
N	Negate (sign bit)	?	Load CCR from stack
Z	Zero	0	Cleared
C	Carry/borrow	1	Set

11

Table 11-7 Instruction set (Continued)

Mnemonic	Addressing modes										Condition codes				
	INH	IMM	DIR	EXT	REL	IX	IX1	IX2	BSC	BTB	H	I	N	Z	C
COM											.	.	◇	◇	1
CPX											.	.	◇	◇	◇
DEC											.	.	◇	◇	.
EOR											.	.	◇	◇	.
INC											.	.	◇	◇	.
JMP										
JSR										
LDA											.	.	◇	◇	.
LDX											.	.	◇	◇	.
LSL											.	.	◇	◇	◇
LSR											.	.	0	◇	◇
MUL											0	.	.	.	0
NEG											.	.	◇	◇	◇
NOP										
ORA											.	.	◇	◇	.
ROL											.	.	◇	◇	◇
ROR											.	.	◇	◇	◇
RSP										
RTI											?	?	?	?	?
RTS										
SBC											.	.	◇	◇	◇
SEC											1
SEI											.	1	.	.	.
STA											.	.	◇	◇	.
STOP											.	0	.	.	.
STX											.	.	◇	◇	.
SUB											.	.	◇	◇	◇
SWI											.	1	.	.	.
TAX										
TST											.	.	◇	◇	.
TXA										
WAIT											.	0	.	.	.

Address mode abbreviations

BS	Bit set/clear	IMM	Immediate
C			
BTB	Bit test & branch	IX	Indexed (no offset)
DIR	Direct	IX1	Indexed, 1 byte offset
EXT	Extended	IX2	Indexed, 2 byte offset

 Not implemented

Condition code symbols

H	Half carry (from bit 3)	◇	Tested and set if true, cleared otherwise
I	Interrupt mask	•	Not affected
N	Negate (sign bit)	?	Load CCR from stack
Z	Zero	0	Cleared
C	Carry/borrow	1	Set

Table 11-8 M68HC05 opcode map

High Low	Bit manipulation		Branch		Read/modify/write				Control			Register/memory				High Low
	BTB	BSC	REL	DIR	INH	DIR	INH	IX1	IX	INH	IMM	DIR	EXT	IX2	IX1	
0	0000	1	2	3	4	5	6	7	8	9	A	B	C	D	E	F
0000	BRSET0	BSET0	BRA	NEG	NEGA	NEG	NEG	NEG	RTI	1000	SUB	SUB	SUB	SUB	SUB	SUB
0001	BRCLD0	BCLD0	BRN						RTS		CMP	CMP	CMP	CMP	CMP	CMP
0010	BRSET1	BSET1	BHI		MUL						SBC	SBC	SBC	SBC	SBC	SBC
0011	BRCLRT	BCLRT	BLS	COM	COMA	COMX	COM	COM	SWI		CPX	CPX	CPX	CPX	CPX	CPX
0100	BRSET2	BSET2	BCC	LSR	LSRA	LSRX	LSR	LSR			AND	AND	AND	AND	AND	AND
0101	BRCLR2	BCLR2	BCS								BIT	BIT	BIT	BIT	BIT	BIT
0110	BRSET3	BSET3	BNE	ROR	RORA	RORX	ROR	ROR			LDA	LDA	LDA	LDA	LDA	LDA
0111	BRCLR3	BCLR3	BEQ	ASP	ASRA	ASRX	ASR	ASR	TAX		STA	STA	STA	STA	STA	STA
1000	BRSET4	BSET4	BHCC	LSL	LSLA	LSLX	LSL	LSL			EOR	EOR	EOR	EOR	EOR	EOR
1001	BRCLR4	BCLR4	BHCS	ROL	ROLA	ROLX	ROL	ROL			ADC	ADC	ADC	ADC	ADC	ADC
1010	BRSET5	BSET5	BPL	DEC	DECA	DECX	DEC	DEC			ORA	ORA	ORA	ORA	ORA	ORA
1011	BRCLR5	BCLR5	BMI								ADD	ADD	ADD	ADD	ADD	ADD
1100	BRSET6	BSET6	BMC	INC	INCA	INCX	INC	INC			JMP	JMP	JMP	JMP	JMP	JMP
1101	BRCLR6	BCLR6	BMS	TST	TSTA	TSTX	TST	TST			BSR	BSR	BSR	BSR	BSR	BSR
1110	BRSET7	BSET7	BIL						STOP		LDX	LDX	LDX	LDX	LDX	LDX
1111	BRCLR7	BCLR7	BH	CLR	CLRA	CLRAX	CLR	CLR	WAIT	TXA	STX	STX	STX	STX	STX	STX

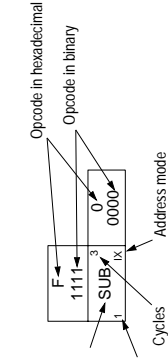

Legend

- IX Indexed (no offset)
- IX1 Indexed, 1 byte (8-bit) offset
- IX2 Indexed, 2 byte (16-bit) offset
- REL Relative
- A Accumulator
- X Index register
- Not implemented

Abbreviations for address modes and registers

- BSC Bit set/clear
- BTB Bit test and branch
- DIR Direct
- EXT Extended
- INH Inherent
- IMM Immediate

11.3 Addressing modes

Ten different addressing modes provide programmers with the flexibility to optimize their code for all situations. The various indexed addressing modes make it possible to locate data tables, code conversion tables and scaling tables anywhere in the memory space. Short indexed accesses are single byte instructions; the longest instructions (three bytes) enable access to tables throughout memory. Short absolute (direct) and long absolute (extended) addressing are also included. One or two byte direct addressing instructions access all data bytes in most applications. Extended addressing permits jump instructions to reach all memory locations.

The term 'effective address' (EA) is used in describing the various addressing modes. The effective address is defined as the address from which the argument for an instruction is fetched or stored. The ten addressing modes of the processor are described below. Parentheses are used to indicate 'contents of' the location or register referred to. For example, (PC) indicates the contents of the location pointed to by the PC (program counter). An arrow indicates 'is replaced by' and a colon indicates concatenation of two bytes. For additional details and graphical illustrations, refer to the *M6805 HMOS/M146805 CMOS Family Microcomputer/ Microprocessor User's Manual* or to the *M68HC05 Applications Guide*.

11.3.1 Inherent

In the inherent addressing mode, all the information necessary to execute the instruction is contained in the opcode. Operations specifying only the index register or accumulator, as well as the control instruction, with no other arguments are included in this mode. These instructions are one byte long.

11.3.2 Immediate

In the immediate addressing mode, the operand is contained in the byte immediately following the opcode. The immediate addressing mode is used to access constants that do not change during program execution (e.g. a constant used to initialize a loop counter).

$$EA = PC+1; PC \leftarrow PC+2$$

11.3.3 Direct

In the direct addressing mode, the effective address of the argument is contained in a single byte following the opcode byte. Direct addressing allows the user to directly address the lowest 256 bytes in memory with a single two-byte instruction.

$$EA = (PC+1); PC \leftarrow PC+2$$
$$\text{Address bus high} \leftarrow 0; \text{Address bus low} \leftarrow (PC+1)$$

11.3.4 Extended

In the extended addressing mode, the effective address of the argument is contained in the two bytes following the opcode byte. Instructions with extended addressing mode are capable of referencing arguments anywhere in memory with a single three-byte instruction. When using the Motorola assembler, the user need not specify whether an instruction uses direct or extended addressing. The assembler automatically selects the short form of the instruction.

$$\begin{aligned}EA &= (PC+1):(PC+2); PC \leftarrow PC+3 \\ \text{Address bus high} &\leftarrow (PC+1); \text{Address bus low} \leftarrow (PC+2)\end{aligned}$$

11.3.5 Indexed, no offset

In the indexed, no offset addressing mode, the effective address of the argument is contained in the 8-bit index register. This addressing mode can access the first 256 memory locations. These instructions are only one byte long. This mode is often used to move a pointer through a table or to hold the address of a frequently referenced RAM or I/O location.

$$\begin{aligned}EA &= X; PC \leftarrow PC+1 \\ \text{Address bus high} &\leftarrow 0; \text{Address bus low} \leftarrow X\end{aligned}$$

11.3.6 Indexed, 8-bit offset

In the indexed, 8-bit offset addressing mode, the effective address is the sum of the contents of the unsigned 8-bit index register and the unsigned byte following the opcode. Therefore the operand can be located anywhere within the lowest 511 memory locations. This addressing mode is useful for selecting the *m*th element in an *n* element table.

$$\begin{aligned}EA &= X+(PC+1); PC \leftarrow PC+2 \\ \text{Address bus high} &\leftarrow K; \text{Address bus low} \leftarrow X+(PC+1) \\ \text{where } K &= \text{the carry from the addition of } X \text{ and } (PC+1)\end{aligned}$$

11.3.7 Indexed, 16-bit offset

In the indexed, 16-bit offset addressing mode, the effective address is the sum of the contents of the unsigned 8-bit index register and the two unsigned bytes following the opcode. This address mode can be used in a manner similar to indexed, 8-bit offset except that this three-byte instruction allows tables to be anywhere in memory. As with direct and extended addressing, the Motorola assembler determines the shortest form of indexed addressing.

$$\begin{aligned}EA &= X+[(PC+1):(PC+2)]; PC \leftarrow PC+3 \\ \text{Address bus high} &\leftarrow (PC+1)+K; \text{Address bus low} \leftarrow X+(PC+2) \\ \text{where } K &= \text{the carry from the addition of } X \text{ and } (PC+2)\end{aligned}$$

11.3.8 Relative

The relative addressing mode is only used in branch instructions. In relative addressing, the contents of the 8-bit signed byte (the offset) following the opcode are added to the PC if, and only if, the branch conditions are true. Otherwise, control proceeds to the next instruction. The span of relative addressing is from -126 to $+129$ from the opcode address. The programmer need not calculate the offset when using the Motorola assembler, since it calculates the proper offset and checks to see that it is within the span of the branch.

$$\begin{aligned} \text{EA} &= \text{PC}+2+(\text{PC}+1); \text{PC} \leftarrow \text{EA} \text{ if branch taken;} \\ &\text{otherwise EA} = \text{PC} \leftarrow \text{PC}+2 \end{aligned}$$

11.3.9 Bit set/clear

In the bit set/clear addressing mode, the bit to be set or cleared is part of the opcode. The byte following the opcode specifies the address of the byte in which the specified bit is to be set or cleared. Any read/write bit in the first 256 locations of memory, including I/O, can be selectively set or cleared with a single two-byte instruction.

$$\begin{aligned} \text{EA} &= (\text{PC}+1); \text{PC} \leftarrow \text{PC}+2 \\ \text{Address bus high} &\leftarrow 0; \text{Address bus low} \leftarrow (\text{PC}+1) \end{aligned}$$

11.3.10 Bit test and branch

The bit test and branch addressing mode is a combination of direct addressing and relative addressing. The bit to be tested and its condition (set or clear) is included in the opcode. The address of the byte to be tested is in the single byte immediately following the opcode byte (EA1). The signed relative 8-bit offset in the third byte (EA2) is added to the PC if the specified bit is set or cleared in the specified memory location. This single three-byte instruction allows the program to branch based on the condition of any readable bit in the first 256 locations of memory. The span of branch is from -125 to $+130$ from the opcode address. The state of the tested bit is also transferred to the carry bit of the condition code register.

$$\begin{aligned} \text{EA1} &= (\text{PC}+1); \text{PC} \leftarrow \text{PC}+2 \\ \text{Address bus high} &\leftarrow 0; \text{Address bus low} \leftarrow (\text{PC}+1) \\ \text{EA2} &= \text{PC}+3+(\text{PC}+2); \text{PC} \leftarrow \text{EA2} \text{ if branch taken;} \\ &\text{otherwise PC} \leftarrow \text{PC}+3 \end{aligned}$$

THIS PAGE LEFT BLANK INTENTIONALLY

12

ELECTRICAL SPECIFICATIONS

This section contains the electrical specifications and associated timing information for the MC68HC05X16.

12.1 Absolute maximum ratings

Table 12-1 Absolute maximum ratings

Rating	Symbol	Value	Unit
Supply voltage ⁽¹⁾	V_{DD}	- 0.5 to +7.0	V
Input voltage	V_{IN}	$V_{SS} - 0.5$ to $V_{DD} + 0.5$	V
Input voltage - bootstrap mode (\overline{IRQ} pin only)	V_{IN}	$V_{SS} - 0.5$ to $2V_{DD} + 0.5$	V
Operating temperature range	T_A	T_L to T_H -40 to +125	°C
Storage temperature range	T_{STG}	- 65 to +150	°C
Current drain per pin ⁽²⁾ (Excluding VDD, VSS, VDD1 and VSS1)			
- Source	I_D	25	mA
- Sink	I_S	45	mA
External oscillator frequency	f_{OSC}	22	MHz

(1) All voltages are with respect to V_{SS} .

(2) Maximum current drain per pin is for one pin at a time, limited by an external resistor.

Note: This device contains circuitry designed to protect against damage due to high electrostatic voltages or electric fields. However, it is recommended that normal precautions be taken to avoid the application of any voltages higher than those given in the maximum ratings table to this high impedance circuit. For maximum reliability all unused inputs should be tied to either V_{SS} or V_{DD} .

12.2 DC electrical characteristics

Table 12-2 DC electrical characteristics

($V_{DD} = 5.0 \text{ Vdc} \pm 10\%$, $V_{SS} = 0 \text{ Vdc}$, $T_A = -40^\circ\text{C}$ to $+125^\circ\text{C}$)

Characteristic ⁽¹⁾	Symbol	Min	Typ ⁽²⁾	Max	Unit
Output voltage $I_{LOAD} = -10 \mu\text{A}$ $I_{LOAD} = +10 \mu\text{A}$	V_{OH} V_{OL}	$V_{DD} - 0.1$ —	— —	— 0.1	V
Output high voltage ($I_{LOAD} = 0.8 \text{ mA}$) PA0-7, PB0-7, PC0-7, TCMP1, TCMP2, Output high voltage ($I_{LOAD} = 1.6 \text{ mA}$) TDO, SCLK, PLMA, PLMB Output high voltage ($I_{LOAD} = -300 \mu\text{A}$) OSC2	V_{OH} V_{OH} V_{OH}	$V_{DD} - 0.8$ $V_{DD} - 0.8$ $V_{DD} - 0.8$	$V_{DD} - 0.2$ $V_{DD} - 0.2$ $V_{DD} - 0.3$	— — —	V
Output low voltage ($I_{LOAD} = 1.6 \text{ mA}$) PA0-7, PB0-7, PC0-7, TCMP1, TCMP2, TDO, SCLK, PLMA, PLMB Output low voltage ($I_{LOAD} = 1.6 \text{ mA}$) RESET Output low voltage ($I_{LOAD} = -100 \mu\text{A}$) OSC2	V_{OL} V_{OL} V_{OL}	— — —	0.1 0.2 0.2	0.4 0.6 0.4	V
Input high voltage PA0-7, PB0-7, PC0-7, PD0-7, OSC1, $\overline{\text{IR}}\overline{\text{O}}$, RESET, TCAP1, TCAP2, RDI, MDS, NWOI	V_{IH}	$0.7 V_{DD}$	—	V_{DD}	V
Input low voltage PA0-7, PB0-7, PC0-7, PD0-7, OSC1, $\overline{\text{IR}}\overline{\text{O}}$, RESET, TCAP1, TCAP2, RDI, MDS, NWOI	V_{IL}	V_{SS}	—	$0.2 V_{DD}$	V
Can comparator I_{DD} (I_{DD1}) ⁽³⁾⁽⁴⁾⁽⁵⁾ Supply current RUN: CAN active ⁽⁶⁾ STOP: CAN active WAIT: CAN asleep ⁽⁷⁾ STOP: CAN asleep	I_{DD1} I_{DD1} I_{DD1} I_{DD1}	— — — —	360 360 32 10	900 900 100 30	μA μA μA μA
MCU I_{DD} ⁽³⁾⁽⁴⁾⁽⁸⁾ Supply current in DIV2 mode RUN (SM = 0): CAN active RUN (SM = 1): CAN active WAIT (SM = 0): CAN active WAIT (SM = 1): CAN active WAIT (SM = 0): CAN asleep WAIT (SM = 1): CAN asleep STOP: CAN active STOP: CAN asleep	I_{DD} I_{DD} I_{DD} I_{DD} I_{DD} I_{DD} I_{DD} I_{DD}	— — — — — — — —	3.6 1.6 1.8 1.5 0.8 0.4 0.5 90	7 3.6 4 3.7 1.4 1.1 1.5 300	mA mA mA mA mA mA mA μA
MCU I_{DD} ⁽³⁾⁽⁵⁾⁽⁸⁾ Supply current in DIV10 mode RUN (SM = 0): CAN active RUN (SM = 1): CAN active WAIT (SM = 0): CAN active WAIT (SM = 1): CAN active WAIT (SM = 0): CAN asleep WAIT (SM = 1): CAN asleep STOP: CAN active STOP: CAN asleep	I_{DD} I_{DD} I_{DD} I_{DD} I_{DD} I_{DD} I_{DD} I_{DD}	— — — — — — — —	6.6 4.6 4.6 4.5 1.2 0.8 0.5 90	13 8 8.5 8 1.8 1.4 1.5 300	mA mA mA mA mA mA mA μA
High-Z leakage current PA0-7, PB0-7, PC0-7, TDO, RESET, SCLK	I_{IL}	—	± 0.2	± 1	μA

12

Table 12-2 DC electrical characteristics $(V_{DD} = 5.0 \text{ Vdc} \pm 10\%, V_{SS} = 0 \text{ Vdc}, T_A = -40^\circ\text{C to } +125^\circ\text{C})$

Characteristic ⁽¹⁾	Symbol	Min	Typ ⁽²⁾	Max	Unit
Input current OSC1= V_{DD} (OSC2= V_{SS})	I_{FH}	- 10	—	—	μA
Input current OSC1= V_{SS} (OSC2= V_{DD})	I_{FL}	—	—	+10	μA
Input current IRQ, TCAP1, TCAP2, RDI, PDO/ANO-PD7/AN7 (channel not selected)	I_{IN}	—	± 0.2	± 1	μA
Capacitance Ports (as input or output), $\overline{\text{RESET}}$, TDO, SCLK IRQ, TCAP1, TCAP2, OSC1, RDI PDO/ANO-PD7/AN7 (A/D off) PDO/ANO-PD7/AN7 (A/D on)	C_{OUT} C_{IN} C_{IN} C_{IN}	— — — —	— — 12 22	12 8 — —	pF pF pF pF
DC injection current ⁽⁹⁾ Port A (PA0-PA7) Port B (PB0-PB7)	$ I_{INJ} $ $ I_{INJ} $	— —	— —	10 10	mA mA

- (1) All I_{DD} measurements taken with suitable decoupling capacitors across the power supply to suppress the transient switching currents inherent in CMOS designs (see Section 2).
- (2) Typical values are at mid point of voltage range and at 25°C only.
- (3) RUN and WAIT I_{DD} : measured using an external square-wave clock source, refer to Figure 2-6(c); all inputs 0.2 V from rail; no DC loads; maximum load on outputs 50pF (20pF on OSC2).
STOP/WAIT I_{DD} : all ports configured as inputs; $V_{IL} = 0.2 \text{ V}$ and $V_{IH} = V_{DD} - 0.2 \text{ V}$; STOP I_{DD} measured with OSC1 = V_{DD} . WAIT I_{DD} is affected linearly by the OSC2 capacitance.
- (4) $f_{OSC} = 4.4 \text{ MHz}$; $f_{BUS} = 2.2 \text{ MHz}$; $f_{CAN} = 2.2 \text{ MHz}$
- (5) $f_{OSC} = 22 \text{ MHz}$; $f_{BUS} = 2.2 \text{ MHz}$; $f_{CAN} = 11 \text{ MHz}$
- (6) These limits are also applicable under the following conditions:
MCU RUN mode/SLOW mode/CAN active
MCU WAIT mode/SLOW mode/CAN active
MCU WAIT mode/CAN active
- (7) These limits are also applicable under the following conditions:
MCU WAIT mode/SLOW mode/CAN asleep
- (8) These currents are the summation of the MCU current + CAN current ($I_{DD} + I_{DD1}$)
- (9) Current injection is guaranteed but not tested.
Functionality of the MCU is guaranteed during injection of dc current up to the maximum specified level.
The maximum specified current for each port is the sum of the magnitudes of the currents on each side of the individual port pins.
Some disturbance of the A/D accuracy is possible during an injection event and is dependent on board layout, power supply decoupling and reference voltage decoupling configurations.

12.3 A/D converter characteristics

Table 12-3 A/D characteristics

($V_{DD} = 5.0 \text{ Vdc} \pm 10\%$, $V_{SS} = 0 \text{ Vdc}$, $T_A = -40^\circ\text{C}$ to $+125^\circ\text{C}$)

Characteristic	Parameter	Min	Max	Unit
Resolution	Number of bits resolved by the A/D	8	—	Bit
Non-linearity	Max deviation from the best straight line through the A/D transfer characteristics ($V_{RH} = V_{DD}$ and $V_{RL} = 0\text{V}$)	—	± 0.5	LSB
Quantization error	Uncertainty due to converter resolution	—	± 0.5	LSB
Absolute accuracy	Difference between the actual input voltage and the full-scale equivalent of the binary code output code for all errors	—	± 1	LSB
Conversion range	Analog input voltage range	V_{RL}	V_{RH}	V
V_{RH}	Maximum analog reference voltage	V_{RL}	$V_{DD} + 0.1$	V
V_{RL}	Minimum analog reference voltage	$V_{SS} - 0.1$	V_{RH}	V
$\Delta V_R^{(1)}$	Minimum difference between V_{RH} and V_{RL}	3	—	V
Conversion time	Total time to perform a single analog to digital conversion a. External clock (OSC1, OSC2) b. Internal RC oscillator	— —	32 32	t_{CYC} μs
Monotonicity	Conversion result never decreases with an increase in input voltage and has no missing codes	GUARANTEED		
Zero input reading	Conversion result when $V_{IN} = V_{RL}$	00	—	Hex
Full scale reading	Conversion result when $V_{IN} = V_{RH}$	—	FF	Hex
Sample acquisition time	Analog input acquisition sampling a. External clock (OSC1, OSC2) b. Internal RC oscillator ⁽²⁾	— —	12 12	t_{CYC} μs
Sample/hold capacitance	Input capacitance on PD0/AN0–PD7/AN7	—	12	pF
Input leakage ⁽³⁾	Input leakage on A/D pins PD0/AN0–PD7/AN7, VRL, VRH	—	1	μA

(1) Performance verified down to 2.5V ΔV_R , but accuracy is tested and guaranteed at $\Delta V_R = 5\text{V} \pm 10\%$.

(2) Source impedances greater than 10k Ω will adversely affect internal charging time during input sampling.

(3) The external system error caused by input leakage current is approximately equal to the product of R source and input current. Input current to A/D channel will be dependent on external source impedance (see [Figure 9-2](#)).

12.4 Control timing

Table 12-4 Control timing

($V_{DD} = 5.0 \text{ Vdc} \pm 10\%$, $V_{SS} = 0 \text{ Vdc}$, $T_A = -40^\circ\text{C}$ to $+125^\circ\text{C}$)

Characteristic	Symbol	Min	Max	Unit
Frequency of operation				
Oscillator frequency	f_{OSC}	0	22	MHz
MCAN module clock frequency	f_{CAN}	0	11	MHz
MCU bus frequency	f_{MCU}	0	2.2	MHz
Cycle time (see Figure 10-1)	t_{CYC}	455	—	ns
Crystal oscillator start-up time (see Figure 10-1)	t_{OXOV}	—	100	ms
Stop recovery start-up time (crystal oscillator)	t_{ILCH}		100	ms
A/D converter stabilization time	t_{ADON}		500	μs
External RESET input pulse width	t_{RL}	1.5	—	t_{CYC}
Power-on RESET output pulse width (mask option)				
4064 cycle	t_{PORL}	4064	—	t_{CYC}
16 cycle	t_{PORL}	16	—	t_{CYC}
Watchdog RESET output pulse width	t_{DOGL}	1.5	—	t_{CYC}
Watchdog time-out	t_{DOG}	6144	7168	t_{CYC}
EEPROM byte erase time	t_{ERA}	10	10	ms
EEPROM byte program time ⁽¹⁾	t_{PROG}	10	10	ms
Timer (see Figure 12-1)				
Resolution ⁽²⁾	t_{RESL}	4	—	t_{CYC}
Input capture pulse width	t_{TH}, t_{TL}	125	—	ns
Input capture pulse period	t_{TLTL}	— ⁽³⁾	—	t_{CYC}
Interrupt pulse width (edge-triggered)	t_{ILIH}	125	—	ns
Interrupt pulse period	t_{ILIL}	— ⁽⁴⁾	—	t_{CYC}
OSC1 pulse width	t_{OH}, t_{OL}	90	—	ns
Write/erase endurance ⁽⁵⁾⁽⁶⁾	—	10000		cycles
Data retention ⁽⁵⁾⁽⁶⁾	—	10		years

- (1) For bus frequencies less than 2 MHz, the internal RC oscillator should be used when programming the EEPROM.
- (2) Since a 2-bit prescaler in the timer must count four external cycles (t_{CYC}), this is the limiting factor in determining the timer resolution.
- (3) The minimum period t_{TLTL} should not be less than the number of cycle times it takes to execute the capture interrupt service routine plus $24 t_{CYC}$.
- (4) The minimum period t_{ILIL} should not be less than the number of cycle times it takes to execute the interrupt service routine plus $21 t_{CYC}$.
- (5) At a temperature of 85°C .
- (6) Refer to Reliability Monitor Report (current quarterly issue) for current failure rate information.

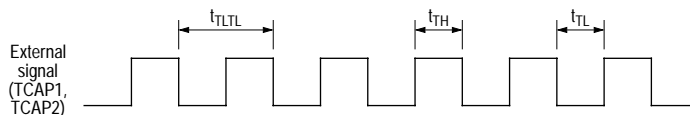

Figure 12-1 Timer relationship

12.5 MCAN bus interface DC electrical characteristics

Table 12-5 MCAN bus interface DC electrical characteristics

($V_{DD} = 5.0 \text{ Vdc} \pm 10\%$, $V_{SS} = 0 \text{ Vdc}$, $T_A = -40^\circ\text{C}$ to $+125^\circ\text{C}$)

Characteristic	Symbol	Min	Max	Unit
MCAN bus input comparator: pins RX0 and RX1				
Input voltage	V_{IN}	0.5	$V_{DD} + 0.5$	V
Common mode range	C_{MR}	1.5	$V_{DD} - 1.5$	V
Latch-up trigger current ⁽¹⁾	I_{LT}	-100	+100	mA
Input offset voltage	V_{OFS}	-30	+30	mV
Hysteresis	V_{HYS}	1	22	mV
$V_{DD} \div 2$ generator: pin VDDH				
Output voltage difference to $V_{DD} \div 2$ for $-100 \mu\text{A} < I_{OUT} < +100 \text{ mA}$	DV_{OUT}	-200	+200	mV
Output current	I_{OUT}	-100	+100	μA
Latch-up trigger current ⁽¹⁾	I_{LT}	-100	+100	mA
MCAN bus output driver: pins TX0 and TX1				
Source current per pin ($V_{OUT} = V_{DD} - 1.0\text{V}$)	I_{OH}	-10	—	mA
Sink current per pin ($V_{OUT} = 1.0\text{V}$)	I_{OL}	10	—	mA
Latch-up trigger current ⁽¹⁾	I_{LT}	-100	+100	mA

($V_{DD} = 5.0 \text{ Vdc} \pm 2\%$, $V_{SS} = 0 \text{ Vdc}$, $T_A = -40^\circ\text{C}$ to $+125^\circ\text{C}$)

Characteristic	Symbol	Min	Max	Unit
$V_{DD} \div 2$ generator: pin VDDH				
Output voltage difference to $V_{DD} \div 2$ for $-100 \mu\text{A} < I_{OUT} < +100 \mu\text{A}$	DV_{OUT}	-180	+180	mV

(1) Maximum DC current should comply with maximum ratings.

12.6 MCAN bus interface control timing characteristics

Table 12-6 MCAN bus interface control timing characteristics

($4.5\text{V} \leq V_{DD} \leq 5.5\text{V}$, $V_{SS} = 0 \text{ Vdc}$, $T_A = -40^\circ\text{C}$ to $+125^\circ\text{C}$)

Characteristic	Symbol	Min	Max	Unit
MCAN bus output driver				
Rise and fall time ($C_{LOAD} = 100\text{pF}$)	T_{RF}	—	25	ns

13

MECHANICAL DATA

13.1 64-pin quad flat pack (QFP) pinout

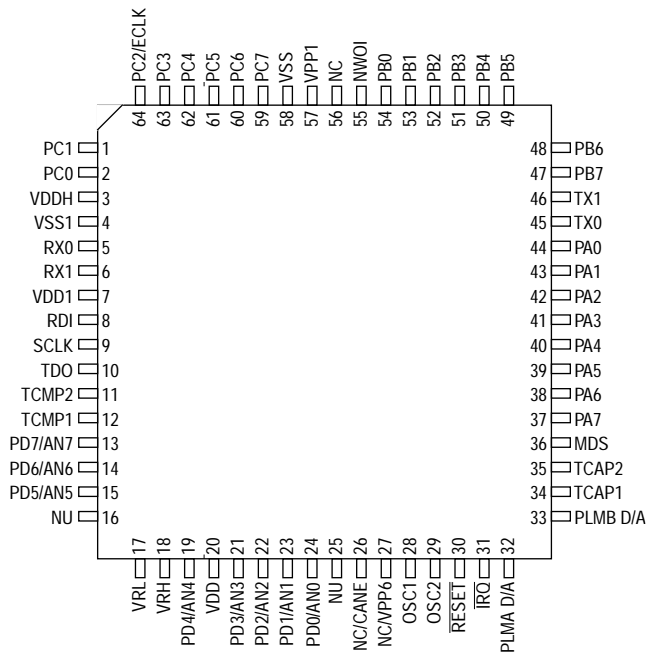

Device	Pin 26	Pin 27
MC68HC05X16, MC68HC05X32	NC	NC
MC68HC705X32	CANE	VPP6

NC = Not connected

NU = Non-user pin (Should be tied to V_{SS} in an electrically noisy environment)

Note: Unless otherwise stated, a pin labelled as 'NU' should be tied to V_{SS} in an electrically noisy environment. Pins labelled 'NC' can be left floating, since they are not bonded to any part of the device.

Figure 13-1 64-pin QFP pinout

13.2 64-pin quad flat pack (QFP) mechanical dimensions

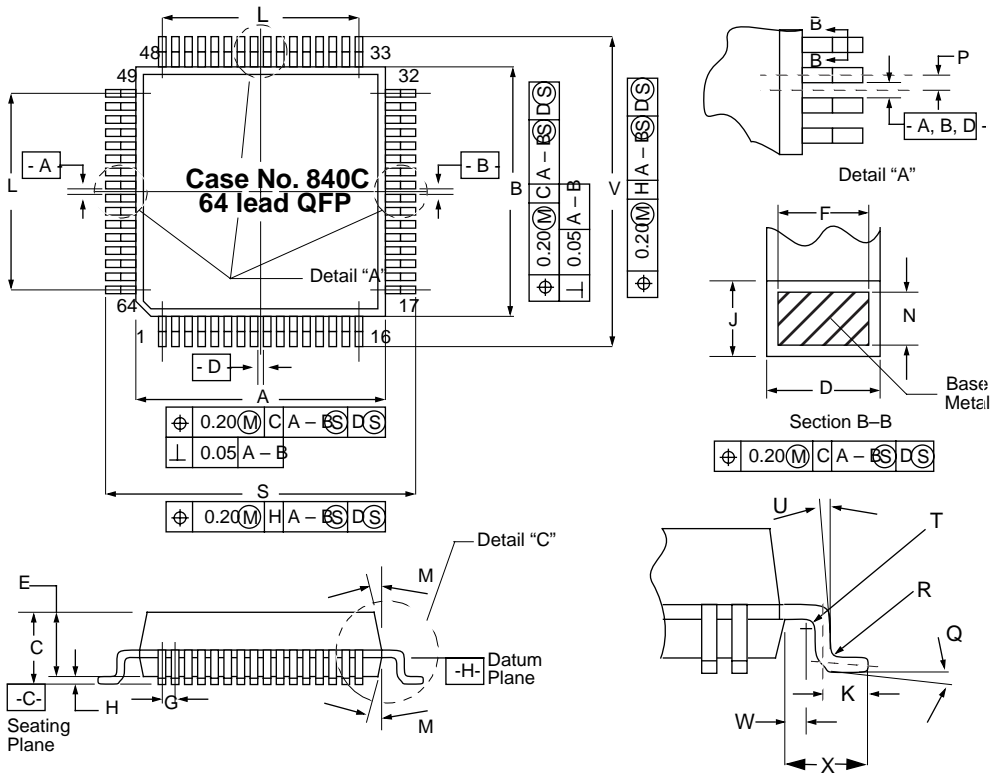

Dim.	Min.	Max.	Notes	Dim.	Min.	Max.
A	13.90	14.10	1. Datum Plane -H- is located at bottom of lead and is coincident with the lead where the lead exits the plastic body at the bottom of the parting line. 2. Datums A-B and -D to be determined at Datum Plane -H-. 3. Dimensions S and V to be determined at seating plane -C-. 4. Dimensions A and B do not include mould protrusion. Allowable mould protrusion is 0.25mm per side. Dimensions A and B do include mould mismatch and are determined at Datum Plane -H-. 5. Dimension D does not include dambar protrusion. Allowable dambar protrusion shall be 0.08 total in excess of the D dimension at maximum material condition. Dambar cannot be located on the lower radius or the foot. 6. Dimensions and tolerancing per ANSI Y 14.5M, 1982. 7. All dimensions in mm.	M	5°	10°
B	13.90	14.10		N	0.130	0.170
C	2.067	2.457		P	0.40	BSC
D	0.30	0.45		Q	2°	8°
E	2.00	2.40		R	0.13	0.30
F	0.30	—		S	16.20	16.60
G	0.80	BSC		T	0.20	REF
H	0.067	0.250		U	9°	15°
J	0.130	0.230		V	16.20	16.60
K	0.50	0.66		W	0.042	NOM
L	12.00	REF	X	1.10	1.30	

Figure 13-2 64-pin QFP mechanical dimensions

14

ORDERING INFORMATION

This section describes the information needed to order the MC68HC05X16 and other family members.

To initiate a ROM pattern for the MCU, you should contact your local field service office, local sales person or Motorola representative. Please note that you will need to supply details such as: mask option selections; temperature range; oscillator frequency; package type; electrical test requirements; and device marking details so that an order can be processed, and a customer specific part number allocated. Refer to [Table 14-1](#) for appropriate part numbers. The part number consists of the device title plus the appropriate suffix. For example, the MC68HC05X16 in 64-pin QFP package at -40 to $+85^{\circ}\text{C}$ would be ordered as: MC68HC05X16CFU.

Table 14-1 MC order numbers

Device Title	Package Type	Suffix 0 to 70°C	Suffix -40 to +85°C	Suffix -40 to +105°C	Suffix -40 to +125°C
MC68HC05X16	64-pin QFP	FU	CFU	VFU	MFU
MC68HC05X32	64-pin QFP	FU	CFU	VFU	MFU
MC68HC705X32	64-pin QFP	FU	CFU	Contact sales	Contact sales

Note: The high speed version of the MC68HC05X32 has the same device title as the standard version. High speed operation is selected via a check box on the order form and will be confirmed on the listing verification form. See [Appendix C](#) for electrical characteristics.

14.1 EPROMS

For the MC68HC05X16, a 16K byte EPROM programmed with the customer's software (positive logic for address and data) should be submitted for pattern generation. All unused bytes should be programmed to \$00. The size of EPROM which should be used for all other family members is listed in [Table 14-2](#).

The EPROM should be clearly labelled, placed in a conductive IC carrier and securely packed.

Table 14-2 EPROMs for pattern generation

Device	Size of EPROM
MC68HC05X16	16K byte
MC68HC05X32	32K byte

14.2 Verification media

All original pattern media (EPROMs) are filed for contractual purposes and are not returned. A computer listing of the ROM code will be generated and returned with a listing verification form. The listing should be thoroughly checked and the verification form completed, signed and returned to Motorola. The signed verification form constitutes the contractual agreement for creation of the custom mask. If desired, Motorola will program blank EPROMs (supplied by the customer) from the data file used to create the custom mask, to aid in the verification process.

14.3 ROM verification units (RVU)

Ten MCUs containing the customer's ROM pattern will be provided for program verification. These units will have been made using the custom mask but are for ROM verification only. For expediency, they are usually unmarked and are tested only at room temperature (25°C) and at 5 Volts. These RVUs are included in the mask charge and are not production parts. They are neither backed nor guaranteed by Motorola Quality Assurance.

A

MC68HC05X32

Important note

The following applies to the D53J MC68HC05X32 mask set only:

- Mask options on the MC68HC05X32 allow the customer to select POR delay cycles and oscillator DIV ratio. However, during reset, options of 4064 cycles POR and DIV 10 are forced, regardless of which options the customer has selected. Therefore, a power-on reset delay of 40640 oscillator cycles is forced.

On the D53J mask set, DIV10 is forced in bootstrap mode. On later mask set revisions, including D69J, DIV2 is forced in bootstrap mode.

The MC68HC05X32 is a device similar to the MC68HC05X16, but with increased RAM and ROM sizes. The entire MC68HC05X16 data sheet applies to the MC68HC05X32, with the exceptions outlined in this appendix.

A.1 Features

- 31232 bytes of user ROM plus 16 bytes of user vectors
- 528 bytes of RAM
- 654 bytes of bootstrap ROM
- Available in 64-pin QFP package
- High speed operation (4 MHz bus speed) available. See [Appendix C](#) for tables of electrical characteristics.
- – 40° to +125°C temperature range

Note: The electrical characteristics for the MC68HC05X16 should not be used for the MC68HC05X32. [Section A.3.1](#) to [Section A.3.4](#) contain data specific to this device.

A.2 Memory map, register outline and block diagram

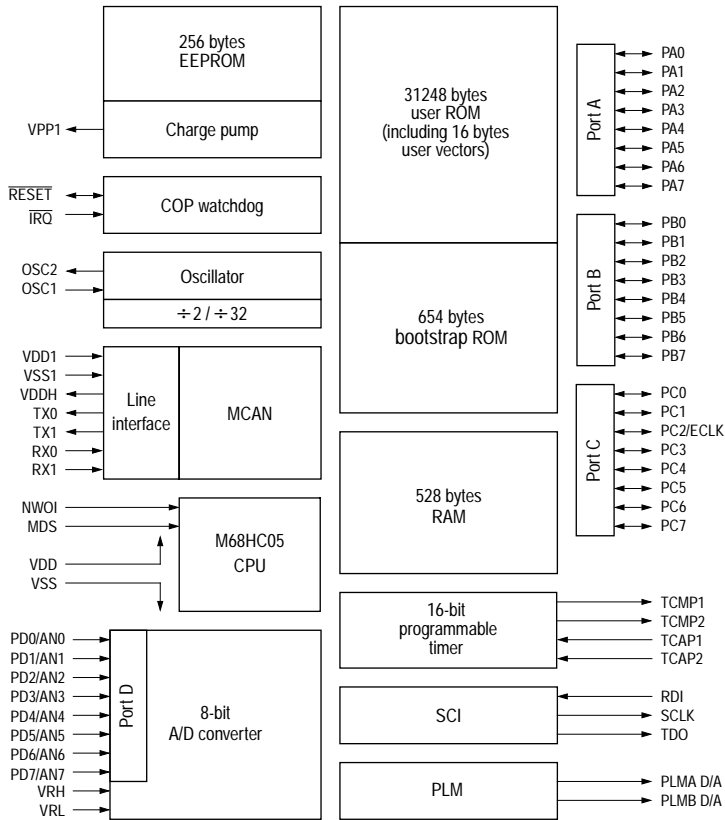

Figure A-1 MC68HC05X32 block diagram

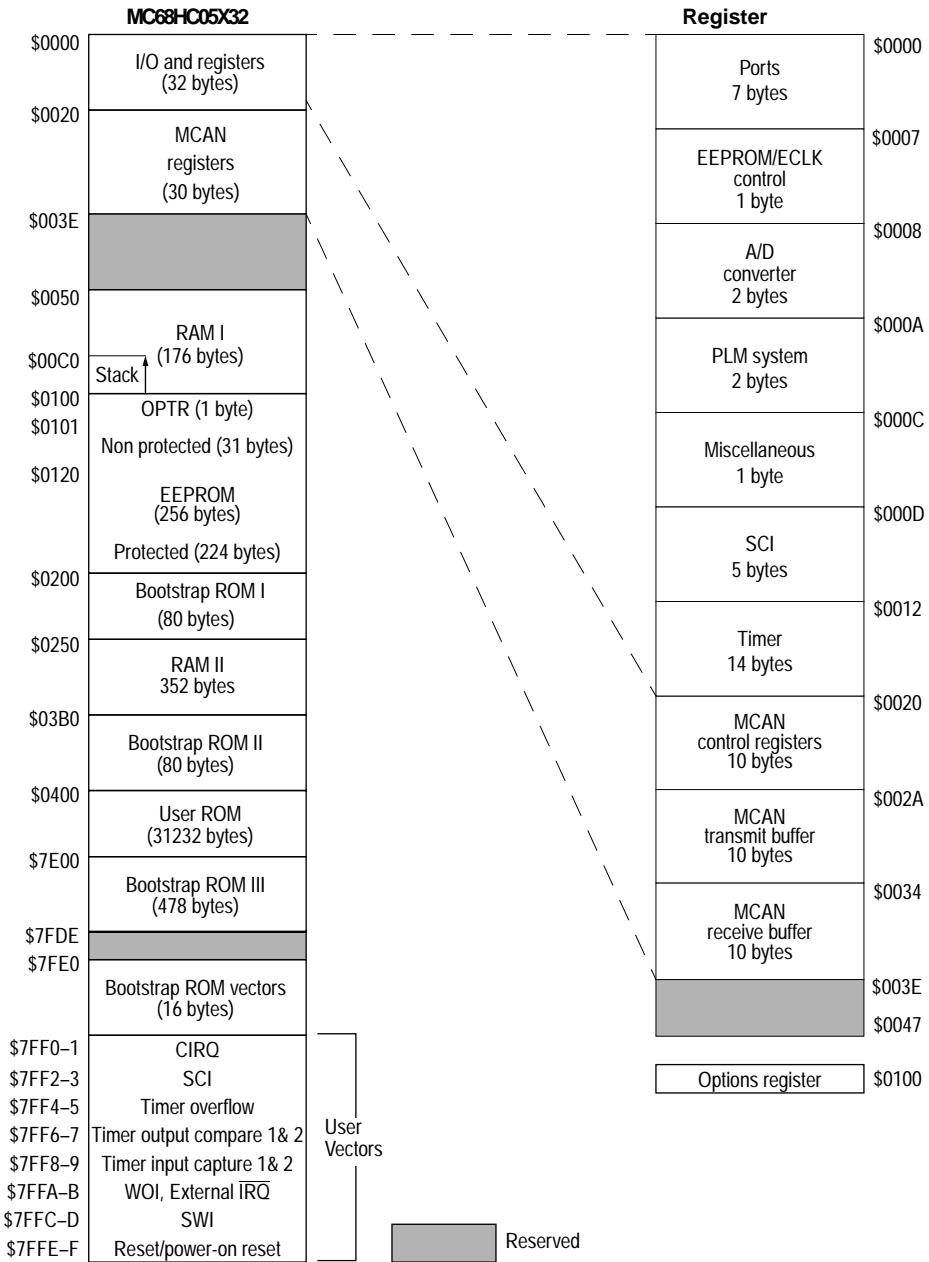

Figure A-2 Memory map of the MC68HC05X32

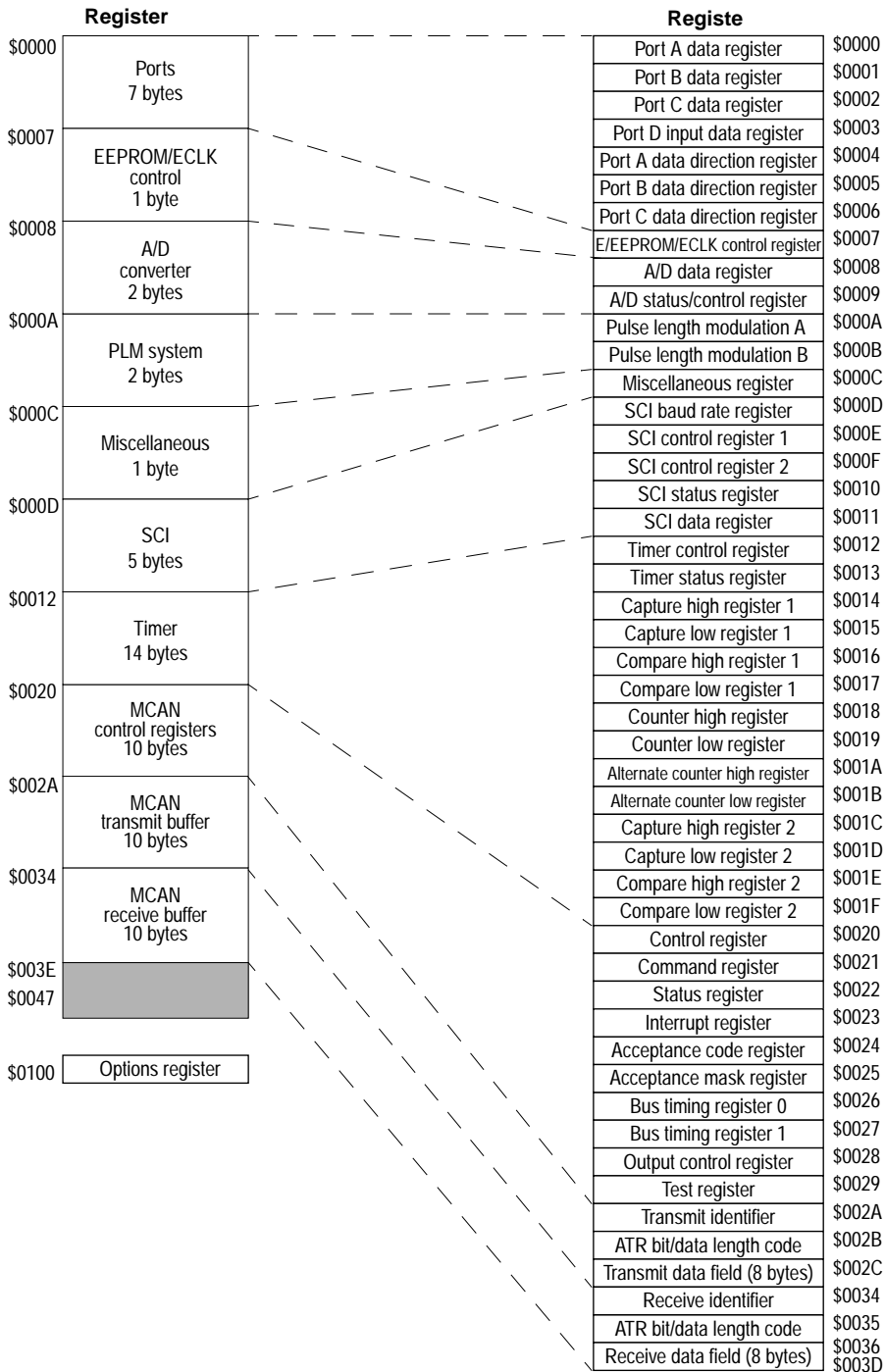

Figure A-2 Memory map of the MC68HC05X32 (Continued)

Table A-1 Register outline

Register name	Address	bit 7	bit 6	bit 5	bit 4	bit 3	bit 2	bit 1	bit 0	State on reset
Port A data (PORTA)	\$0000									Undefined
Port B data (PORTB)	\$0001									Undefined
Port C data (PORTC)	\$0002						PC2/ ECLK			Undefined
Port D data (PORTD)	\$0003	PD7	PD6	PD5	PD4	PD3	PD2	PD1	PD0	Undefined
Port A data direction (DDRA)	\$0004									0000 0000
Port B data direction (DDRB)	\$0005									0000 0000
Port C data direction (DDRC)	\$0006									0000 0000
EEPROM/ECLK control	\$0007	WOIE	CAF	0	0	ECLK	E1ERA	E1LAT	E1PGM	0000 0000
A/D data (ADDATA)	\$0008									0000 0000
A/D status/control (ADSTAT)	\$0009	COCO	ADRC	ADON	0	CH3	CH2	CH1	CH0	0000 0000
Pulse length modulation A (PLMA)	\$000A									0000 0000
Pulse length modulation B (PLMB)	\$000B									0000 0000
Miscellaneous	\$000C	POR ⁽¹⁾	INTP	INTN	INTE	SFA	SFB	SM	WDOG ⁽²⁾	u001 000u
SCI baud rate (BAUD)	\$000D	SPC1	SPC0	SCT1	SCT0	SCT0	SCR2	SCR1	SCR0	00uu uuuu
SCI control 1 (SCCR1)	\$000E	R8	T8		M	WAKE	CPOL	CPHA	LBCL	Undefined
SCI control 2 (SCCR2)	\$000F	TIE	TCIE	RIE	ILIE	TE	RE	RWU	SBK	0000 0000
SCI status (SCSR)	\$0010	TDRE	TC	RDRF	IDLE	OR	NF	FE		1100 000u
SCI data (SCDR)	\$0011									0000 0000
Timer control (TCR)	\$0012	ICIE	OCIE	TOIE	FOLV2	FOLV1	OLV2	IEDG1	OLVL1	0000 00u0
Timer status (TSR)	\$0013	ICF1	OCF1	TOF	ICF2	OCF2				Undefined
Input capture high 1	\$0014									Undefined
Input capture low 1	\$0015									Undefined
Output compare high 1	\$0016									Undefined
Output compare low 1	\$0017									Undefined
Timer counter high	\$0018									1111 1111
Timer counter low	\$0019									1111 1100
Alternate counter high	\$001A									1111 1111
Alternate counter low	\$001B									1111 1100
Input capture high 2	\$001C									Undefined
Input capture low 2	\$001D									Undefined
Output compare high 2	\$001E									Undefined
Output compare low 2	\$001F									Undefined
Options (OPTR) ⁽³⁾	\$0100							EE1P	SEC	Not affected

(1) This bit is set each time there is a power-on reset.

(2) The state of the WDOG bit after reset is dependent upon the mask option selected; 1 = watchdog enabled, 0 = watchdog disabled.

(3) This register is implemented in EEPROM; therefore reset has no effect on the individual bits.

A.3 Electrical specifications

This section contains the electrical specifications and associated timing information for the MC68HC05X32.

A.3.1 Maximum ratings

Table A-2 Maximum ratings

Rating	Symbol	Value	Unit
Supply voltage ⁽¹⁾	V_{DD}	- 0.5 to +7.0	V
Input voltage	V_{IN}	$V_{SS} - 0.5$ to $V_{DD} + 0.5$	V
Input voltage – bootstrap mode (\overline{IRQ} pin only)	V_{IN}	$V_{SS} - 0.5$ to $2V_{DD} + 0.5$	V
Operating temperature range	T_A	T_L to T_H – 40 to +125	°C
Storage temperature range	T_{STG}	– 65 to +150	°C
Current drain per pin ⁽²⁾ (Excluding VDD, VSS, VDD1 and VSS1)			
– Source	I_D	25	mA
– Sink	I_S	45	mA
External oscillator frequency	f_{OSC}	22	MHz

(1) All voltages are with respect to V_{SS} .

(2) Maximum current drain per pin is for one pin at a time, limited by an external resistor.

Note: This device contains circuitry designed to protect against damage due to high electrostatic voltages or electric fields. However, it is recommended that normal precautions be taken to avoid the application of any voltages higher than those given in the maximum ratings table to this high impedance circuit. For maximum reliability all unused inputs should be tied to either V_{SS} or V_{DD} .

A.3.2 DC electrical characteristics

Table A-3 DC electrical characteristics

($V_{DD} = 5.0 \text{ Vdc} \pm 10\%$, $V_{SS} = 0 \text{ Vdc}$, $T_A = -40^\circ\text{C}$ to $+125^\circ\text{C}$)

Characteristic ⁽¹⁾	Symbol	Min	Typ ⁽²⁾	Max	Unit
Output voltage $I_{LOAD} = -10 \mu\text{A}$ $I_{LOAD} = +10 \mu\text{A}$	V_{OH} V_{OL}	$V_{DD} - 0.1$ —	— —	— 0.1	V
Output high voltage ($I_{LOAD} = 0.8 \text{ mA}$) PA0-7, PB0-7, PC0-7, TCMP1, TCMP2, Output high voltage ($I_{LOAD} = 1.6 \text{ mA}$) TDO, SCLK, PLMA, PLMB Output high voltage ($I_{LOAD} = -300 \mu\text{A}$) OSC2	V_{OH} V_{OH} V_{OH}	$V_{DD} - 0.8$ $V_{DD} - 0.8$ $V_{DD} - 0.8$	$V_{DD} - 0.2$ $V_{DD} - 0.2$ $V_{DD} - 0.3$	— — —	V
Output low voltage ($I_{LOAD} = 1.6 \text{ mA}$) PA0-7, PB0-7, PC0-7, TCMP1, TCMP2, TDO, SCLK, PLMA, PLMB Output low voltage ($I_{LOAD} = 1.6 \text{ mA}$) RESET Output low voltage ($I_{LOAD} = -100 \mu\text{A}$) OSC2	V_{OL} V_{OL} V_{OL}	— — —	0.1 0.2 0.2	0.4 0.6 0.4	V
Input high voltage PA0-7, PB0-7, PC0-7, PD0-7, OSC1, $\overline{IR0}$, RESET, TCAP1, TCAP2, RDI, MDS, NWOI	V_{IH}	$0.7 V_{DD}$	—	V_{DD}	V
Input low voltage PA0-7, PB0-7, PC0-7, PD0-7, OSC1, $\overline{IR0}$, RESET, TCAP1, TCAP2, RDI, MDS, NWOI	V_{IL}	V_{SS}	—	$0.2 V_{DD}$	V
Can comparator I_{DD} (I_{DD1}) ⁽³⁾⁽⁴⁾⁽⁵⁾ Supply current in DIV2 mode RUN: CAN active ⁽⁶⁾ STOP: CAN active WAIT: CAN asleep ⁽⁷⁾ STOP: CAN asleep	I_{DD1} I_{DD1} I_{DD1} I_{DD1}	— — — —	360 360 32 10	900 900 100 30	μA μA μA μA
MCU I_{DD} ⁽³⁾⁽⁴⁾⁽⁸⁾ Supply current in DIV 2 mode RUN (SM = 0): CAN active RUN (SM = 1): CAN active WAIT (SM = 0): CAN active WAIT (SM = 1): CAN active WAIT (SM = 0): CAN asleep WAIT (SM = 1): CAN asleep STOP: CAN active STOP: CAN asleep	I_{DD} I_{DD} I_{DD} I_{DD} I_{DD} I_{DD} I_{DD} I_{DD} I_{DD}	— — — — — — — — —	3.6 1.6 1.8 1.5 0.8 0.4 0.5 90	7 3.6 4 3.7 1.4 1.1 1.5 300	mA mA mA mA mA mA mA mA mA
MCU I_{DD} ⁽³⁾⁽⁵⁾⁽⁸⁾ Supply current in DIV 10 mode RUN (SM = 0): CAN active RUN (SM = 1): CAN active WAIT (SM = 0): CAN active WAIT (SM = 1): CAN active WAIT (SM = 0): CAN asleep WAIT (SM = 1): CAN asleep STOP: CAN active STOP: CAN asleep	I_{DD} I_{DD} I_{DD} I_{DD} I_{DD} I_{DD} I_{DD} I_{DD}	— — — — — — — —	6.6 4.6 4.6 4.5 1.2 0.8 0.5 90	13 8 8.5 8 1.8 1.4 1.5 300	mA mA mA mA mA mA mA mA
High-Z leakage current PA0-7, PB0-7, PC0-7, TDO, RESET, SCLK	I_{IL}	—	± 0.2	± 1	μA

Table A-3 DC electrical characteristics

($V_{DD} = 5.0 \text{ Vdc} \pm 10\%$, $V_{SS} = 0 \text{ Vdc}$, $T_A = -40^\circ\text{C}$ to $+125^\circ\text{C}$)

Characteristic ⁽¹⁾	Symbol	Min	Typ ⁽²⁾	Max	Unit
Input current OSC1= V_{DD} (OSC2= V_{SS})	I_{FH}	-10	—	—	μA
Input current OSC1= V_{SS} (OSC2= V_{DD})	I_{FL}	—	—	+10	μA
Input current IRQ, TCAP1, TCAP2, RDI, PDO/AN0-PD7/AN7 (channel not selected)	I_{IN}	—	± 0.2	± 1	μA
Capacitance Ports (as input or output), $\overline{\text{RESET}}$, TDO, SCLK IRQ, TCAP1, TCAP2, OSC1, RDI PDO/AN0-PD7/AN7 (A/D off) PDO/AN0-PD7/AN7 (A/D on)	C_{OUT} C_{IN} C_{IN} C_{IN}	— — — —	— — 12 22	12 8 — —	pF pF pF pF
DC injection current ⁽⁹⁾ Port A (PA0-PA7) Port B (PB0-PB7)	$ I_{INJ} $ $ I_{INJ} $	— —	— —	10 10	mA mA

- (1) All I_{DD} measurements taken with suitable decoupling capacitors across the power supply to suppress the transient switching currents inherent in CMOS designs (see Section 2).
- (2) Typical values are at mid point of voltage range and at 25°C only.
- (3) RUN and WAIT I_{DD} : measured using an external square-wave clock source, refer to Figure 2-6(c); all inputs 0.2 V from rail; no DC loads; maximum load on outputs 50pF (20pF on OSC2).
STOP/WAIT I_{DD} : all ports configured as inputs; $V_{IL} = 0.2 \text{ V}$ and $V_{IH} = V_{DD} - 0.2 \text{ V}$; STOP I_{DD} measured with OSC1 = V_{DD} . WAIT I_{DD} is affected linearly by the OSC2 capacitance.
- (4) $f_{OSC} = 4.4 \text{ MHz}$; $f_{BUS} = 2.2 \text{ MHz}$; $f_{CAN} = 2.2 \text{ MHz}$
- (5) $f_{OSC} = 22 \text{ MHz}$; $f_{BUS} = 2.2 \text{ MHz}$; $f_{CAN} = 11 \text{ MHz}$
- (6) These limits are also applicable under the following conditions:
MCU RUN mode/SLOW mode/CAN active
MCU WAIT mode/SLOW mode/CAN active
MCU WAIT mode/CAN active
- (7) These limits are also applicable under the following conditions:
MCU WAIT mode/SLOW mode/CAN asleep
- (8) These currents are the summation of the MCU current + CAN current ($I_{DD} + I_{DD1}$)
- (9) Current injection is guaranteed but not tested.
Functionality of the MCU is guaranteed during injection of dc current up to the maximum specified level.
The maximum specified current for each port is the sum of the magnitudes of the currents on each side of the individual port pins.
Some disturbance of the A/D accuracy is possible during an injection event and is dependent on board layout, power supply decoupling and reference voltage decoupling configurations.

A.3.3 A/D converter characteristics

Table A-4 A/D characteristics

($V_{DD} = 5.0 \text{ Vdc} \pm 10\%$, $V_{SS} = 0 \text{ Vdc}$, $T_A = -40^\circ\text{C}$ to $+125^\circ\text{C}$)

Characteristic	Parameter	Min	Max	Unit
Resolution	Number of bits resolved by the A/D	8	—	Bit
Non-linearity	Max deviation from the best straight line through the A/D transfer characteristics ($V_{RH} = V_{DD}$ and $V_{RL} = 0\text{V}$)	—	± 0.5	LSB
Quantization error	Uncertainty due to converter resolution	—	± 0.5	LSB
Absolute accuracy	Difference between the actual input voltage and the full-scale equivalent of the binary code output code for all errors	—	± 1	LSB
Conversion range	Analog input voltage range	V_{RL}	V_{RH}	V
V_{RH}	Maximum analog reference voltage	V_{RL}	$V_{DD} + 0.1$	V
V_{RL}	Minimum analog reference voltage	$V_{SS} - 0.1$	V_{RH}	V
$\Delta V_R^{(1)}$	Minimum difference between V_{RH} and V_{RL}	3	—	V
Conversion time	Total time to perform a single analog to digital conversion a. External clock (OSC1, OSC2) b. Internal RC oscillator	— —	32 32	t_{CYC} μs
Monotonicity	Conversion result never decreases with an increase in input voltage and has no missing codes	GUARANTEED		
Zero input reading	Conversion result when $V_{IN} = V_{RL}$	00	—	Hex
Full scale reading	Conversion result when $V_{IN} = V_{RH}$	—	FF	Hex
Sample acquisition time	Analog input acquisition sampling a. External clock (OSC1, OSC2) b. Internal RC oscillator ⁽²⁾	— —	12 12	t_{CYC} μs
Sample/hold capacitance	Input capacitance on PD0/AN0–PD7/AN7	—	12	pF
Input leakage ⁽³⁾	Input leakage on A/D pins PD0/AN0–PD7/AN7, VRL, VRH	—	1	μA

(1) Performance verified down to $2.5\text{V } \Delta V_R$, but accuracy is tested and guaranteed at $\Delta V_R = 5\text{V} \pm 10\%$.

(2) Source impedances greater than $10\text{k}\Omega$ will adversely affect internal charging time during input sampling.

(3) The external system error caused by input leakage current is approximately equal to the product of R source and input current. Input current to A/D channel will be dependent on external source impedance (see [Figure 9-2](#)).

A.3.4 Control timing

Table A-5 Control timing

($V_{DD} = 5.0 \text{ Vdc} \pm 10\%$, $V_{SS} = 0 \text{ Vdc}$, $T_A = -40^\circ\text{C}$ to $+125^\circ\text{C}$)

Characteristic	Symbol	Min	Max	Unit
Frequency of operation				
Oscillator frequency	f_{OSC}	0	22	MHz
MCAN module clock frequency	f_{CAN}	0	11	MHz
MCU bus frequency	f_{MCU}	0	2.2	MHz
Cycle time (see Figure 10-1)	t_{CYC}	455	—	ns
Crystal oscillator start-up time (see Figure 10-1)	t_{OXOV}	—	100	ms
Stop recovery start-up time (crystal oscillator)	t_{ILCH}		100	ms
A/D converter stabilization time	t_{ADON}		500	μs
External RESET input pulse width	t_{RL}	1.5	—	t_{CYC}
Power-on RESET output pulse width (mask option)				
4064 cycle	t_{PORL}	4064	—	t_{CYC}
16 cycle	t_{PORL}	16	—	t_{CYC}
Watchdog RESET output pulse width	t_{DOGL}	1.5	—	t_{CYC}
Watchdog time-out	t_{DOG}	6144	7168	t_{CYC}
EEPROM byte erase time	t_{ERA}	10	10	ms
EEPROM byte program time ⁽¹⁾	t_{PROG}	10	10	ms
Timer (see Figure A-3)				
Resolution ⁽²⁾	t_{RESL}	4	—	t_{CYC}
Input capture pulse width	t_{TH}, t_{TL}	125	—	ns
Input capture pulse period	t_{TLTL}	— ⁽³⁾	—	t_{CYC}
Interrupt pulse width (edge-triggered)	t_{ILIH}	125	—	ns
Interrupt pulse period	t_{ILIL}	— ⁽⁴⁾	—	t_{CYC}
OSC1 pulse width	t_{OH}, t_{OL}	90	—	ns
Write/erase endurance ⁽⁵⁾⁽⁶⁾	—	10000		cycles
Data retention ⁽⁵⁾⁽⁶⁾	—	10		years

- (1) For bus frequencies less than 2 MHz, the internal RC oscillator should be used when programming the EEPROM.
- (2) Since a 2-bit prescaler in the timer must count four external cycles (t_{CYC}), this is the limiting factor in determining the timer resolution.
- (3) The minimum period t_{TLTL} should not be less than the number of cycle times it takes to execute the capture interrupt service routine plus 24 t_{CYC} .
- (4) The minimum period t_{ILIL} should not be less than the number of cycle times it takes to execute the interrupt service routine plus 21 t_{CYC} .
- (5) At a temperature of 85°C.
- (6) Refer to Reliability Monitor Report (current quarterly issue) for current failure rate information.

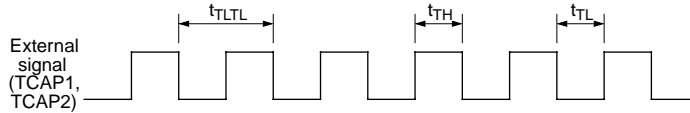

Figure A-3 Timer relationship

A.3.5 MCAN bus interface DC electrical characteristics

Table 1-6 MCAN bus interface DC electrical characteristics

($V_{DD} = 5.0 \text{ Vdc} \pm 10\%$, $V_{SS} = 0 \text{ Vdc}$, $T_A = -40^\circ\text{C}$ to $+125^\circ\text{C}$)

Characteristic	Symbol	Min	Max	Unit
MCAN bus input comparator: pins RX0 and RX1				
Input voltage	V_{IN}	0.5	$V_{DD} + 0.5$	V
Common mode range	C_{MR}	1.5	$V_{DD} - 1.5$	V
Latch-up trigger current ⁽¹⁾	I_{LT}	-100	+100	mA
Input offset voltage	V_{OFS}	-30	+30	mV
Hysteresis	V_{HYS}	1	22	mV
$V_{DD} \div 2$ generator: pin VDDH				
Output voltage difference to $V_{DD} \div 2$ for $-100 \mu\text{A} < I_{OUT} < +100 \mu\text{A}$	DV_{OUT}	-200	+200	mV
Output current	I_{OUT}	-100	+100	mA
Latch-up trigger current ⁽¹⁾	I_{LT}	-100	+100	mA
MCAN bus output driver: pins TX0 and TX1				
Source current per pin ($V_{OUT} = V_{DD} - 1.0\text{V}$)	I_{OH}	-10	—	mA
Sink current per pin ($V_{OUT} = 1.0\text{V}$)	I_{OL}	10	—	mA
Latch-up trigger current ⁽¹⁾	I_{LT}	-100	+100	mA

($V_{DD} = 5.0 \text{ Vdc} \pm 2\%$, $V_{SS} = 0 \text{ Vdc}$, $T_A = -40^\circ\text{C}$ to $+125^\circ\text{C}$)

Characteristic	Symbol	Min	Max	Unit
$V_{DD} \div 2$ generator: pin VDDH				
Output voltage difference to $V_{DD} \div 2$ for $-100 \mu\text{A} < I_{OUT} < +100 \mu\text{A}$	DV_{OUT}	-180	+180	mV

(1) Maximum DC current should comply with maximum ratings.

A.3.6 MCAN bus interface control timing characteristics

Table 1-7 MCAN bus interface control timing characteristics

($4.5V \leq V_{DD} \leq 5.5V$, $V_{SS} = 0$ Vdc, $T_A = -40^\circ\text{C}$ to $+125^\circ\text{C}$)

Characteristic	Symbol	Min	Max	Unit
MCAN bus output driver Rise and fall time ($C_{LOAD} = 100\text{pF}$)	T_{RF}	—	25	ns

B

MC68HC705X32

Important note

The following applies to the D59J MC68HC705X32 mask set only.

- A mask option register (MOR) on the MC68HC705X32 allows the customer to select POR delay cycles and oscillator DIV ratio. However, during reset, options of 4064 cycles POR and DIV10 are forced, regardless of which options the customer has selected. Therefore, a power-on reset delay of 40640 oscillator cycles is forced.

On the D59J mask set, the oscillator divide ratio depends on the CANE pin:

CANE = 1	DIV10 forced in bootloader mode
CANE = 0	DIV2 forced in bootloader mode

On later mask set revisions, including G47V, DIV2 is forced in bootloader mode, regardless of the CANE pin.

The following applies to the D40J and D59J MC68HC705X32 mask sets only:

- The minimum external RESET input pulse width, t_{RL} ([Table B-10](#)) is $1.5 t_{CYC}$
- Maximum bus speed 2.2 MHz

The MC68HC705X32 is a device similar to the MC68HC05X16, but with 32K bytes of EPROM instead of 16K bytes of ROM. In addition, the bootstrap routines available in the MC68HC05X16 are replaced by bootstrap routines specific to the MC68HC705X32. The entire MC68HC05X16 data sheet applies to the MC68HC705X32, with the exceptions outlined in this appendix.

B.1 Features

- –40 to +125°C operating temperature range
- 31232 bytes user EPROM plus 16 bytes of EPROM user vectors
- 528 bytes of RAM
- 654 bytes bootstrap ROM
- Simultaneous programming of up to 16 bytes of EPROM
- 4 MHz bus speed
- Available in 64-pin QFP package

Note: The electrical characteristics for the MC68HC05X16 should not be used for the MC68HC705X32. [Section B.9.2](#) and [Section B.9.5](#) contain data specific to this device.

B.2 VPP6

The VPP6 pin is the voltage input for the EPROM in both read and programming modes (see [Section B.5](#)).

B.3 CANE

This pin is the MCAN enable input. If CANE is connected to VDD, the internal MCAN module is selected and its registers are mapped at addresses \$0020 to \$003D.

Note: Although this pin can be left floating to disconnect the MCAN module, it is advisable to connect it to VSS when the module is not in use.

B.4 Block diagram, memory map and register outline

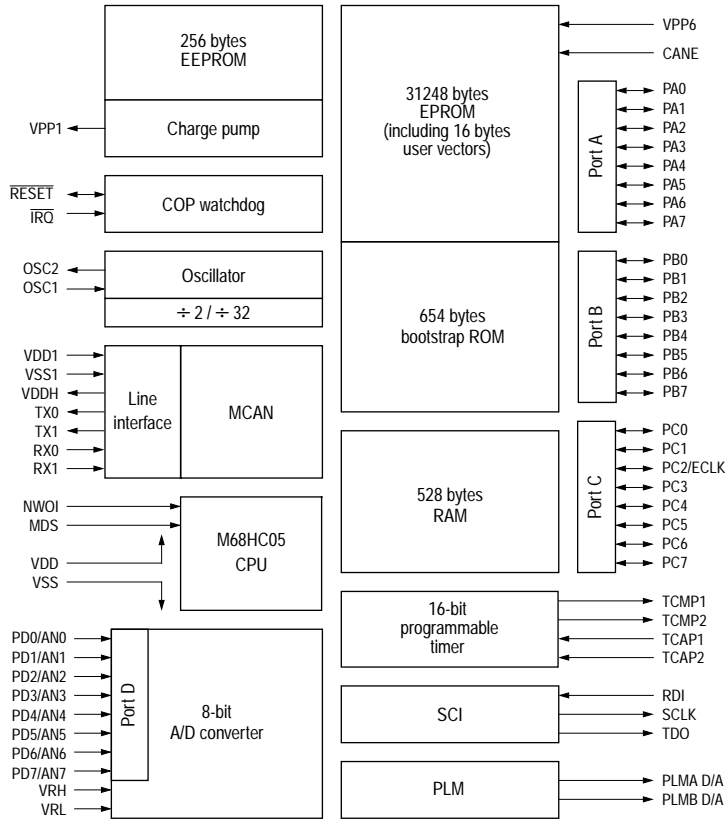

Figure B-1 MC68HC705X32 block diagram

Table B-1 Register outline

Register name	Address	bit 7	bit 6	bit 5	bit 4	bit 3	bit 2	bit 1	bit 0	State on reset
Port A data (PORTA)	\$0000									Undefined
Port B data (PORTB)	\$0001									Undefined
Port C data (PORTC)	\$0002						PC2/ECLK			Undefined
Port D data (PORTD)	\$0003	PD7	PD6	PD5	PD4	PD3	PD2	PD1	PD0	Undefined
Port A data direction (DDRA)	\$0004									0000 0000
Port B data direction (DDRB)	\$0005									0000 0000
Port C data direction (DDRC)	\$0006									0000 0000
EEPROM/ECLK control	\$0007	WOIE	CAF	E6LAT	E6PGM	ECLK	E1ERA	E1LAT	E1PGM	0000 0000
A/D data (ADDATA)	\$0008									0000 0000
A/D status/control (ADSTAT)	\$0009	COCO	ADRC	ADON	0	CH3	CH2	CH1	CH0	0000 0000
Pulse length modulation A (PLMA)	\$000A									0000 0000
Pulse length modulation B (PLMB)	\$000B									0000 0000
Miscellaneous	\$000C	POR ⁽¹⁾	INTP	INTN	INTE	SFA	SFB	SM	WDOG ⁽²⁾	u001 000u
SCI baud rate (BAUD)	\$000D	SPC1	SPC0	SCT1	SCT0	SCT0	SCR2	SCR1	SCR0	00uu uuuu
SCI control 1 (SCCR1)	\$000E	R8	T8		M	WAKE	CPOL	CPHA	LBCL	Undefined
SCI control 2 (SCCR2)	\$000F	TIE	TCIE	RIE	ILIE	TE	RE	RWU	SBK	0000 0000
SCI status (SCSR)	\$0010	TDRE	TC	RDRF	IDLE	OR	NF	FE		1100 000u
SCI data (SCDR)	\$0011									0000 0000
Timer control (TCR)	\$0012	ICIE	OCIE	TOIE	FOLV2	FOLV1	OLV2	IEDG1	OLVL1	0000 00u0
Timer status (TSR)	\$0013	ICF1	OCF1	TOF	ICF2	OCF2				Undefined
Input capture high 1	\$0014									Undefined
Input capture low 1	\$0015									Undefined
Output compare high 1	\$0016									Undefined
Output compare low 1	\$0017									Undefined
Timer counter high	\$0018									1111 1111
Timer counter low	\$0019									1111 1100
Alternate counter high	\$001A									1111 1111
Alternate counter low	\$001B									1111 1100
Input capture high 2	\$001C									Undefined
Input capture low 2	\$001D									Undefined
Output compare high 2	\$001E									Undefined
Output compare low 2	\$001F									Undefined
Options (OPTR) ⁽³⁾	\$0100							EE1P	SEC	Not affected
Mask option register (MOR) ⁽⁴⁾	\$7FDE	WOI	DIV2	DIV8	RTIM	RWAT	WWAT	PBPD	PCPD	Not affected

(1) This bit is set each time there is a power-on reset.

(2) The state of the WDOG bit after reset is dependent upon the mask option selected; 1 = watchdog enabled, 0 = watchdog disabled.

(3) This register is implemented in EEPROM; therefore reset has no effect on the individual bits.

(4) This register is implemented in EPROM; therefore reset has no effect on the individual bits. However, please read the important note on page B-1.

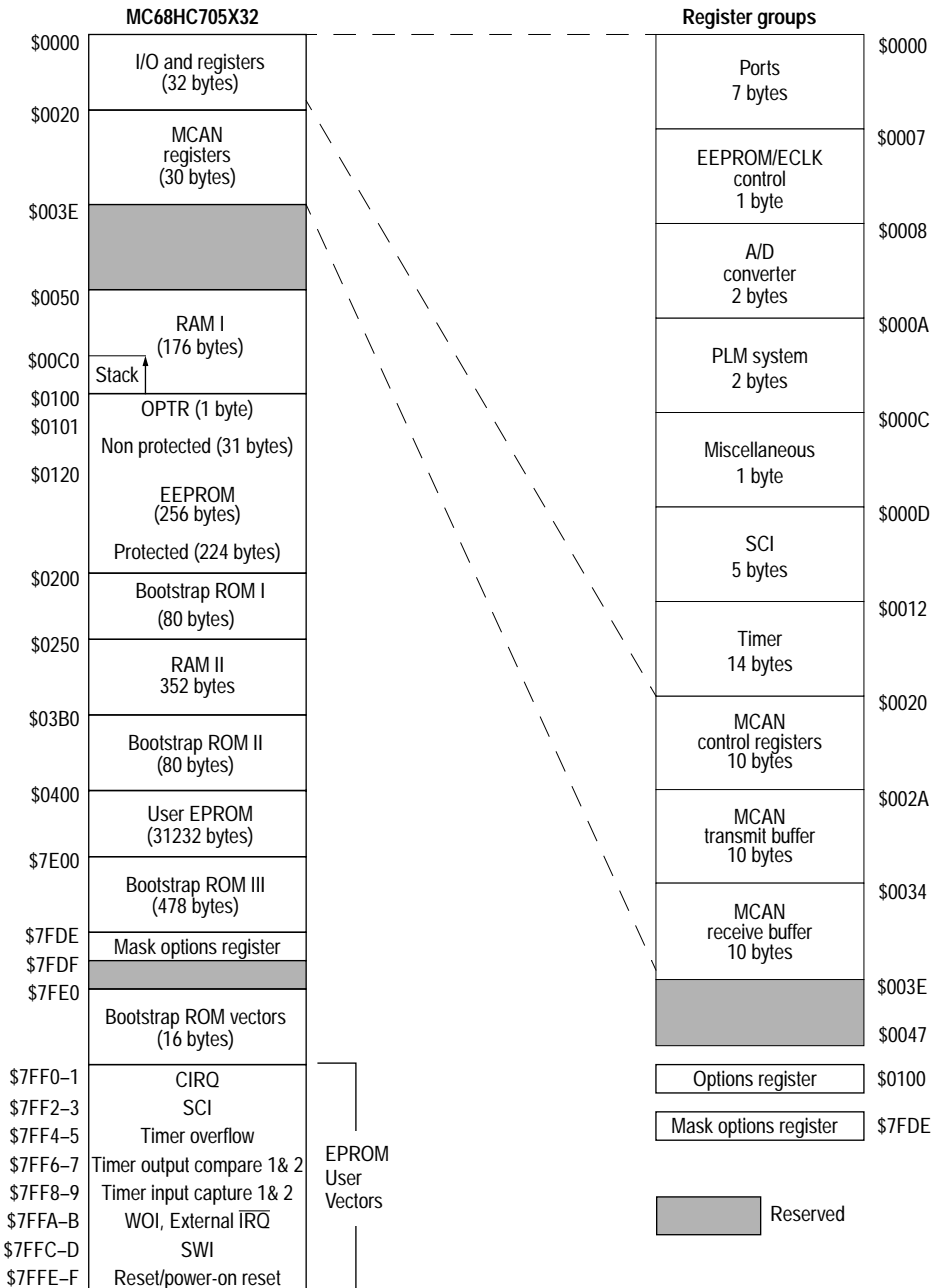

Figure B-2 Memory map of the MC68HC705X32

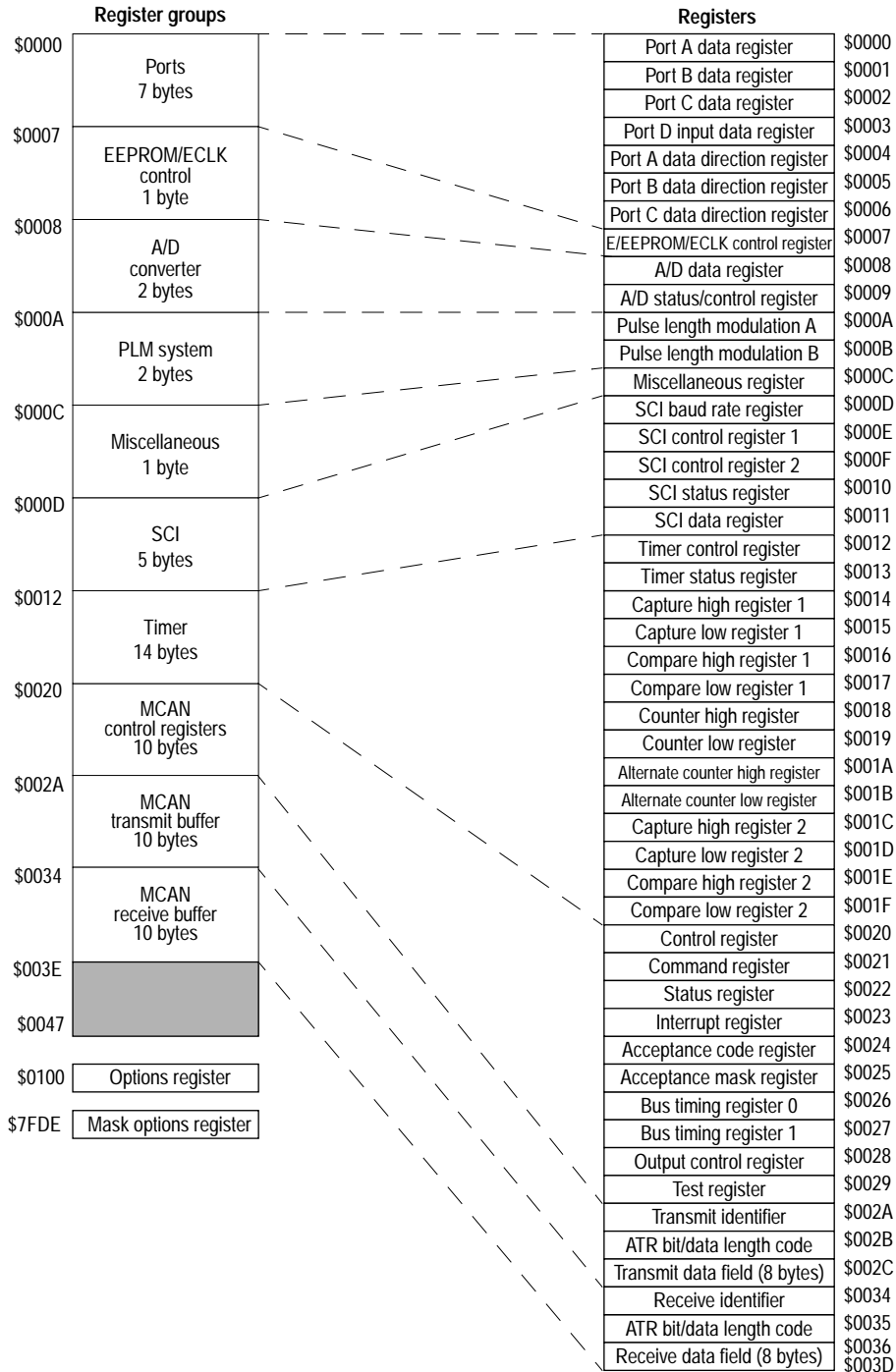

Figure B-2 Memory map of the MC68HC705X32 (Continued)

B.5 EPROM

The MC68HC705X32 memory map is given in [Figure B-2](#). The device has a total of 31248 bytes of EPROM. 16 bytes are used for the reset and interrupt vectors from address \$7FF0 to \$7FFF. The main EPROM block of 31232 bytes is located from \$0400 to \$7DFF. One byte of EPROM is used as an option register and is located at address \$7FDE.

The EPROM can be completely tested before assembly with sequences of both program and erase. It is finally erased before being typically assembled in a package with no erase window. Therefore, only programming is possible and the EPROM operates as a PROM.

The EPROM array is supplied by the VPP6 pin in both read and program modes. Typically the user's software would be loaded into a programming board where V_{PP6} is controlled by one of the bootstrap loader routines. It would then be placed in an application where no programming occurs. In this case the VPP6 pin should be hardwired to V_{DD} .

Warning: A minimum V_{PP6R} voltage must be applied to the VPP6 pin at all times, including power-on. Failure to do so could result in permanent damage to the device. Unless otherwise stated, EPROM programming is guaranteed at ambient temperature (25°C) only.

B.5.1 EPROM read operation

The execution of a program in the EPROM address range or a load from the EPROM are both read operations. The E6LAT bit in the EPROM/EEPROM control register should be cleared to '0' which automatically resets the E6PGM bit. In this way the EPROM is read like a normal ROM. Reading the EPROM with the E6LAT bit set will give data that does not correspond to the actual memory content. As interrupt vectors are in EPROM, they will not be loaded when E6LAT is set. Similarly, the bootstrap ROM routines cannot be executed when E6LAT is set. In read mode, the VPP6 pin must be at the V_{PP6R} level. When entering the STOP mode, the EPROM is automatically set to the read mode.

Note: An erased byte reads as \$00.

B.5.2 EPROM program operation

Typically the EPROM will be programmed by the bootstrap routines resident in the on-chip ROM. However, the user program can be used to program some EPROM locations if the proper procedure is followed. In particular, the programming sequence must be running in RAM, as the EPROM will not be available for code execution while the E6LAT bit is set. The V_{PP6} switching must occur externally after the E6PGM bit is set, for example under control of a signal generated on a pin by the programming routine.

Note: When the part becomes a PROM, only the cumulative programming of bits to logic '1' is possible if multiple programming is made on the same byte.

To allow simultaneous programming of up to sixteen bytes, these bytes must be in the same group of addresses which share the same most significant address bits; only the four least significant bits can change.

B.5.3 EPROM/EEPROM/ECLK control register

	Address	bit 7	bit 6	bit 5	bit 4	bit 3	bit 2	bit 1	bit 0	State on reset
EPROM/EEPROM/ECLK control	\$0007	WOIE	CAF	E6LAT	E6PGM	ECLK	E1ERA	E1LAT	E1PGM	0000 0000

WOIE — Wired-OR interrupt enable bit

1 (set) – Wired-OR interrupts are enabled, provided the WOI bit in register MOR is set.

0 (clear) – Wired-OR interrupts are disabled.

The WOIE bit can be used to enable the wired-OR interrupts (WOI) on the NWOI pin and on all port B pins that have been programmed as inputs. WOI is activated if the WOIE bit is set and if the WOI bit in the mask options register (MOR) is also set (see [Section B.7](#)). If WOI is not set then WOIE is forced to zero. External and power-on resets clear the WOIE bit.

CAF — MCAN asleep flag

This flag is set by the MCU when the MCAN module enters SLEEP mode. This is the only indication that the MCAN is asleep (see [Section 5.5](#)). The bit is cleared when the MCAN wakes up.

1 (set) – The MCAN module is in sleep mode.

0 (clear) – The MCAN module is not in sleep mode.

E6LAT — EPROM programming latch enable bit

- 1 (set) – Address and up to sixteen data bytes can be latched into the EPROM for further programming providing the E6PGM bit is cleared.
- 0 (clear) – Data can be read from the EPROM or firmware ROM; the E6PGM bit is cleared when E6LAT is '0'.

STOP, power-on and external reset clear the E6LAT bit.

Note: After the $t_{\text{ERA}1}$ erase time or $t_{\text{PROG}1}$ programming time, the E6LAT bit has to be reset to zero in order to clear the E6PGM bit.

E6PGM — EPROM program enable bit

This bit is the EPROM program enable bit. It can be set to '1' to enable programming only after E6LAT is set and at least one byte is written to the EPROM. It is not possible to clear this bit using software but clearing E6LAT will always clear E6PGM.

Table B-2 EPROM control bits description

E6LAT	E6PGM	Description
0	0	Read/execute in EPROM
1	0	Ready to write address/data to EPROM
1	1	programming in progress

Note: The E6PGM bit can never be set while the E6LAT bit is at zero.

ECLK — External clock output

See [Section 4.3](#).

E1ERA — EEPROM erase/programming bit

Providing the E1LAT and E1PGM bits are at logic one, this bit indicates whether the access to the EEPROM is for erasing or programming purposes.

- 1 (set) – An erase operation will take place.
- 0 (clear) – A programming operation will take place.

Once the program/erase EEPROM address has been selected, E1ERA cannot be changed.

E1LAT — EEPROM programming latch enable bit

- 1 (set) – Address and data can be latched into the EEPROM for further program or erase operations, providing the E1PGM bit is cleared.
- 0 (clear) – Data can be read from the EEPROM. The E1ERA bit and the E1PGM bit are reset to zero when E1LAT is '0'.

STOP, power-on and external reset clear the E1LAT bit.

Note: After the $t_{\text{ERA}1}$ erase time or $t_{\text{PROG}1}$ programming time, the E1LAT bit has to be reset to zero in order to clear the E1ERA bit and the E1PGM bit.

1) E1PGM — EEPROM charge pump enable/disable

- 1 (set) – Internal charge pump generator switched on.
- 0 (clear) – Internal charge pump generator switched off.

When the charge pump generator is on, the resulting high voltage is applied to the EEPROM array. This bit cannot be set before the data is selected, and once this bit has been set it can only be cleared by clearing the E1LAT bit.

A summary of the effects of setting/clearing bits 0, 1 and 2 of the control register are given in [Table B-3](#).

Table B-3 EEPROM1 control bits description

E1ERA	E1LAT	E1PGM	Description
0	0	0	Read condition
0	1	0	Ready to load address/data for program/erase
0	1	1	Byte programming in progress
1	1	0	Ready for byte erase (load address)
1	1	1	Byte erase in progress

Note: The E1PGM and E1ERA bits are cleared when the E1LAT bit is at zero.

B.6 EEPROM options register (OPTR)

Options (OPTR) ⁽¹⁾	Address	bit 7	bit 6	bit 5	bit 4	bit 3	bit 2	bit 1	bit 0	State on reset
	\$0100							EE1P	SEC	Not affected

(1) This register is implemented in EEPROM; therefore reset has no effect on the individual bits.

EE1P – EEPROM protect bit

In order to achieve a higher degree of protection, the EEPROM is split into two parts, both working from the VPP1 charge pump. Part 1 of the EEPROM array (32 bytes from \$0100 to \$011F) cannot be protected; part 2 (224 bytes from \$0120 to \$01FF) is protected by the EE1P bit in the options register.

- 1 (set) – Part 2 of the EEPROM array is not protected; all 256 bytes of EEPROM can be accessed for any read, erase or programming operations.
- 0 (clear) – Part 2 of the EEPROM array is protected; any attempt to erase or program a location will be unsuccessful.

When this bit is set (erased), the protection will remain until the next power-on or external reset. EE1P can only be written to '0' when the E1LAT bit in the EEPROM control register is set.

Note: The EEPROM1 protect function is disabled while in bootstrap mode.

SEC — Secure bit

This bit allows the EPROM and EEPROM1 to be secured from external access. When this bit is in the erased state (set), the EPROM and EEPROM1 content is not secured and the device may be used in non user mode. When the SEC bit is programmed to 'zero', the EPROM and EEPROM1 content is secured by prohibiting entry to the non user mode. To deactivate the secure bit, the EPROM has to be erased by exposure to a high density ultraviolet light, and the device has to be entered into the EPROM erase verification mode with PD1 set. When the SEC bit is changed, its new value will have no effect until the next power-on or external reset.

- 1 (set) – EEPROM/EPROM not protected.
- 0 (clear) – EEPROM/EPROM protected.

B.7 Mask option register (MOR)

Address	bit 7	bit 6	bit 5	bit 4	bit 3	bit 2	bit 1	bit 0	State on reset	
Mask option register (MOR) ⁽¹⁾	\$7FDE	WOI	DIV2	DIV8	RTIM	RWAT	WWAT	PBPD	PCPD	Not affected

(1) This register is implemented in EPROM; therefore reset has no effect on the individual bits. However, please read the important note on page B-1.

WOI — Wired-OR interrupt enable

- 1 (set) — Wired-OR interrupts are enabled, provided the WOIE bit in the EPROM/EEPROM/ECLK control register is set.
- 0 (clear) — Wired-OR interrupts are disabled, irrespective of the WOIE bit in the EPROM/EEPROM/ECLK control register.

The WOI bit can be used to enable the wired-OR interrupt (WOI) on all port B pins that have been programmed as inputs. WOI is activated if the WOI bit is set and if the WOIE bit in the OPR register is also set.

DIV2, DIV8 — Clock divide ratio selection

The DIV2 and DIV8 bits are used to select the CPU clock divide ratio (see [Table B-4](#)). Note that a divide-by-two clock ratio is forced in bootstrap mode, regardless of the DIV2 and DIV8 values.

Table B-4 Clock divide ratio selection

DIV2	DIV8	Clock divide ratio
1	1	2
1	0	4
0	1	8
0	0	10

RTIM — Reset time

This bit can modify the time t_{PORL} , where the \overline{RESET} pin is kept low after a power-on reset.

- 1 (set) — $t_{PORL} = 16$ cycles.
- 0 (clear) — $t_{PORL} = 4064$ cycles.

RWAT — Watchdog after reset

This bit can modify the status of the watchdog counter after reset.

- 1 (set) — The watchdog will be active immediately following power-on or external reset (except in bootstrap mode).
- 0 (clear) — The watchdog system will be disabled after power-on or external reset.

WWAT — Watchdog during WAIT mode

This bit can modify the status of the watchdog counter during WAIT mode.

- 1 (set) — The watchdog will be active during WAIT mode.
- 0 (clear) — The watchdog system will be disabled during WAIT mode.

PBPD — Port B pull-down

This bit, when programmed, connects a resistive pull-down on each pin of port B. This pull-down, R_{PD} , is active on a given pin only while it is an input.

- 1 (set) — Pull-down resistors are connected to all 8 pins of port B; the pull-down, R_{PD} , is active only while the pin is an input.
- 0 (clear) — No pull-down resistors are connected.

PCPD — Port C pull-down

This bit, when programmed, connects a resistive pull-down on each pin of port C. This pull-down, R_{PD} , is active on a given pin only while it is an input.

- 1 (set) — Pull-down resistors are connected to all 8 pins of port C; the pull-down, R_{PD} , is active only while the pin is an input.
- 0 (clear) — No pull-down resistors are connected.

B.8 Bootstrap mode

Oscillator divide-by-two is forced in bootstrap mode; all other options stay as programmed in the mask options register (see [Section B.7](#)).

The bootstrap firmware is located in mask ROM at address locations \$0200 to \$024F, \$03B0 to \$3FFF, \$7E00 to \$7FDD and \$7FE0 to \$7FEF. This firmware can be used to program the EPROM and the EEPROM, to check if the EPROM is erased, or to load and execute routines in RAM.

After reset, while going to the bootstrap mode, the vector located at address \$7FEE and \$7FEF ($\overline{\text{RESET}}$) is fetched to start execution of the bootstrap program. To place the part in bootstrap mode, the following conditions must be met during transition of the $\overline{\text{RESET}}$ pin from low to high:

- 1) $\overline{\text{IRQ}}$ pin at $2 \times V_{DD}$ or MDS pin at V_{DD}
- 2) TCAP1 pin at V_{DD}
- 3) TCAP2 pin at V_{SS}

The hold time on the $\overline{\text{IRQ}}$, MDS, TCAP1 and TCAP2 pins is two clock cycles after the external $\overline{\text{RESET}}$ pin is brought high.

When the MC68HC705X32 is placed in the bootstrap mode, the bootstrap reset vector will be fetched and the bootstrap firmware will start to execute. [Table B-5](#) shows the conditions required to enter each level of bootstrap mode on the rising edge of $\overline{\text{RESET}}$.

The bootstrap program first copies part of itself into RAM (except 'RAM parallel load'), as the program cannot be executed in ROM during verification/programming of the EPROM.

Table B-5 Mode of operation selection

MDS		$\overline{\text{IRQ}}$	TCAP1	TCAP2	PD1	PD2	PD3	PD4	Mode
V_{SS}	AND	V_{SS} to V_{DD}	V_{SS} to V_{DD}	x	x	x	x	x	Single-chip mode
Bootstrap mode:									
V_{DD}	OR	$2V_{DD}$	V_{DD}	V_{SS}	0	0	0	x	EPROM erase check
V_{DD}	OR	$2V_{DD}$	V_{DD}	V_{SS}	1	0	0	x	EPROM erase check, erase EEPROM, parallel EPROM/EEPROM program/verify
V_{DD}	OR	$2V_{DD}$	V_{DD}	V_{SS}	0	1	0	x	Parallel EEPROM only verify (SEC bit not active)
V_{DD}	OR	$2V_{DD}$	V_{DD}	V_{SS}	1	1	0	x	EPROM erase check, erase EEPROM, parallel EPROM only program/verify
V_{DD}	OR	$2V_{DD}$	V_{DD}	V_{SS}	x	1	1	0	Jump to RAM \$0051 (SEC bit not active)
V_{DD}	OR	$2V_{DD}$	V_{DD}	V_{SS}	x	x	1	1	Serial RAM load and execute (SEC bit not active)

x = Don't care

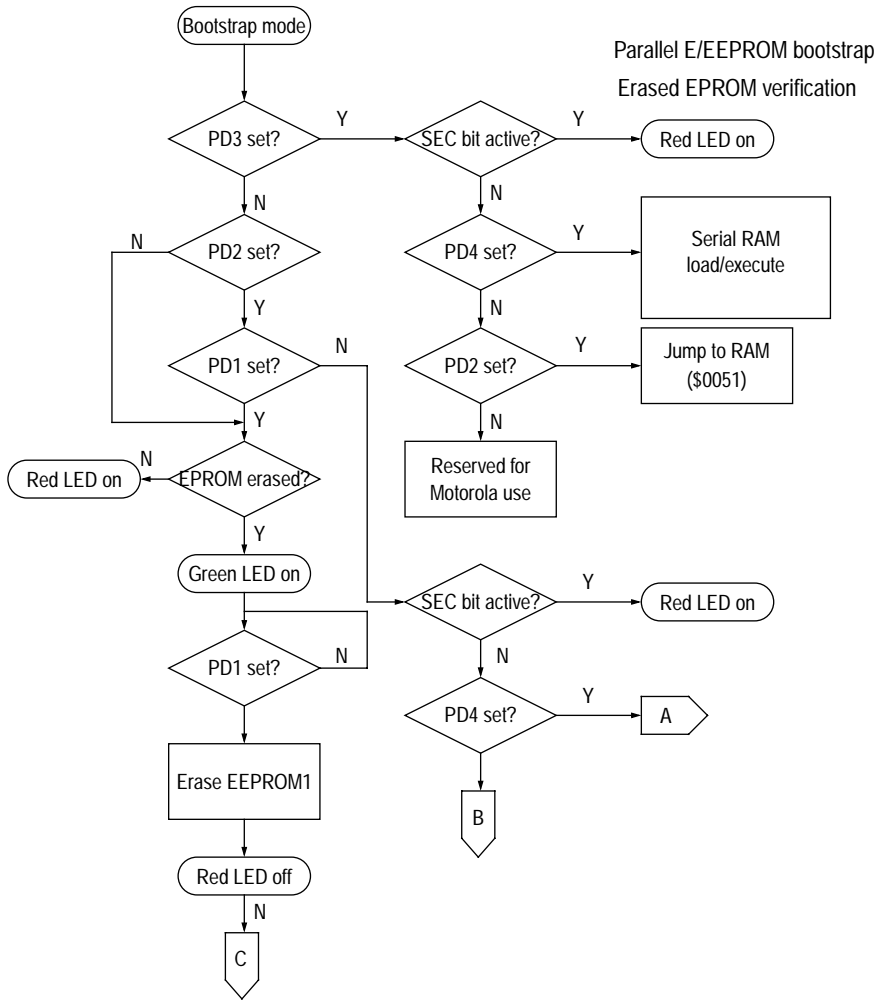

Figure B-3 Modes of operation flow chart

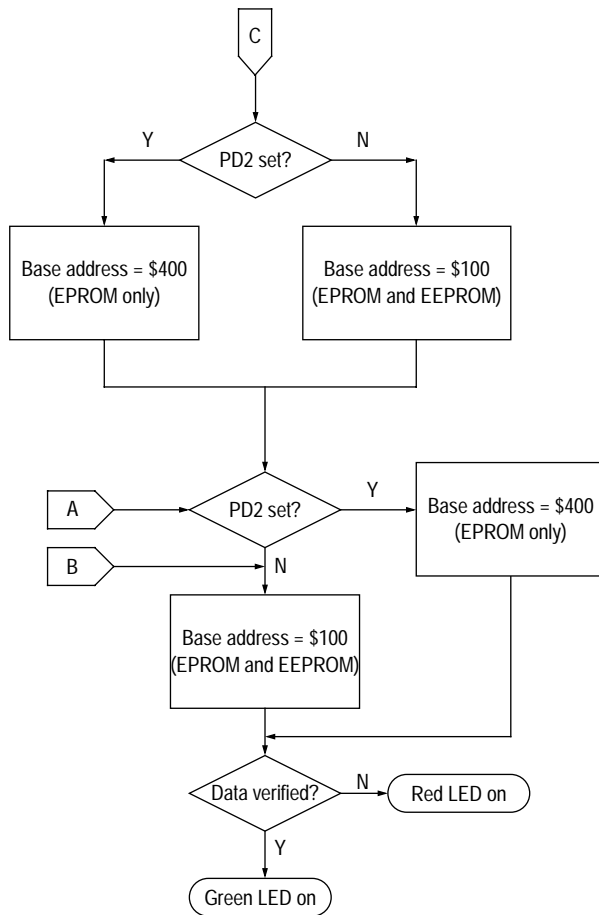

Figure B-3 Modes of operation flow chart (Continued)

B.8.1 Erased EPROM verification and EEPROM erasure

If a non \$00 byte is detected, the red LED will be turned on and the routine will stop (see [Figure B-3](#)). Only when the whole EPROM array is verified as erased will the green LED be turned on. PD1 is then checked. If PD1=0, the bootstrap program stops here and no programming occurs until a high level is sensed on PD1.

If PD1 = 1, the bootstrap program proceeds to erase the EEPROM1 for a nominal 2.5 seconds (4.0 MHz crystal). It is then checked for complete erasure; if any EEPROM byte is not erased, the program will stop before erasing the SEC byte. When both EPROM and EEPROM1 are completely erased and the security bit is cleared the programming operation can be performed. A schematic diagram of the circuit required for erased EPROM verification is shown in [Figure B-6](#).

B.8.2 EPROM/EEPROM parallel bootstrap

Within this mode there are various subsections which can be utilised by correctly configuring the port pins shown in [Table B-5](#).

The erased EPROM verification program will be executed first as described in [Section B.8.1](#). When PD2=0, the programming time is set to 5 milliseconds with the bootstrap program and verify for the EPROM taking approximately 15 seconds. The EPROM will be loaded in increasing address order with non EPROM segments being skipped by the loader. Simultaneous programming is performed by reading sixteen bytes of data before actual programming is performed, thus dividing the loading time of the internal EPROM by 16. If any block of 16 EPROM bytes or 1 EEPROM byte of data is in the erased state, no programming takes place, thus speeding up the execution time.

Parallel data is entered through Port A, while the 15-bit address is output on port B, PC0 to PC4 and TCMP1 and TCMP2. If the data comes from an external EPROM, the handshake can be disabled by connecting together PC5 and PC6. If the data is supplied by a parallel interface, handshake will be provided by PC5 and PC6 according to the timing diagram of [Figure B-4](#) (see also [Figure B-5](#)).

During programming, the green LED will flash at about 3 Hz.

Upon completion of the programming operation, the EPROM and EEPROM1 content will be checked against the external data source. If programming is verified the green LED will stay on, while an error will cause the red LED to be turned on. [Figure B-6](#) is a schematic diagram of a circuit which can be used to program the EPROM or to load and execute data in the RAM.

Note: The entire EPROM and EEPROM1 can be loaded from the external source; if it is desired to leave a segment undisturbed, the data for this segment should be all \$00s for EPROM data and all \$FFs for EEPROM1 data.

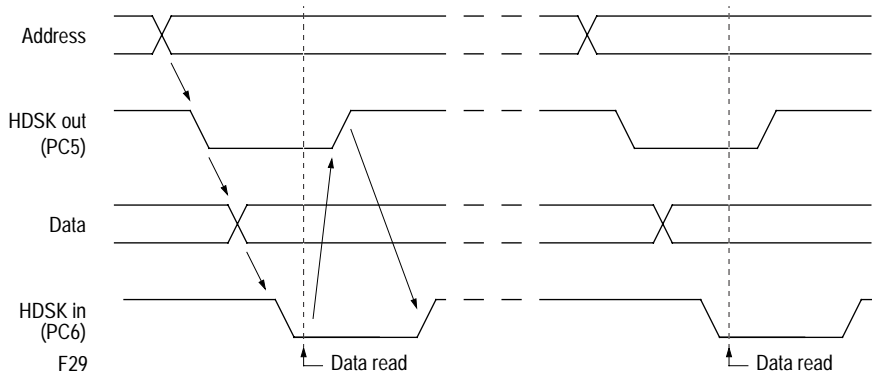
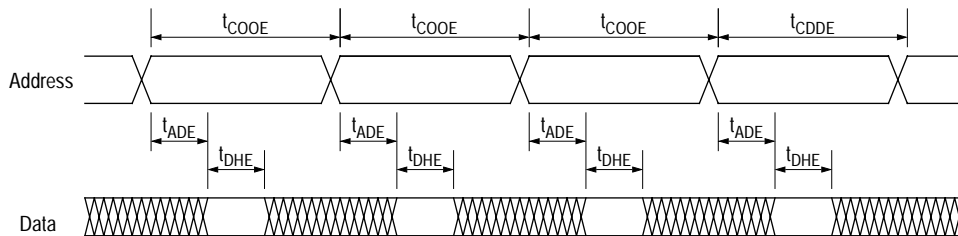

Figure B-4 Timing diagram with handshake



t_{ADE} max (address to data delay)	5 machine cycles
t_{DHA} min (data hold time)	14 machine cycles
t_{COOE} (load cycle time)	$117 \text{ machine cycles} < t_{COOE} < 150 \text{ machine cycles}$
t_{CDDE} (programming cycle time)	$t_{COOE} + t_{PROG}$ (5 ms nominal for EPROM; 10ms for EEPROM1)

$$1 \text{ machine cycle} = 1/(2f_0(Xtal))$$

Figure B-5 Parallel EPROM loader timing diagram

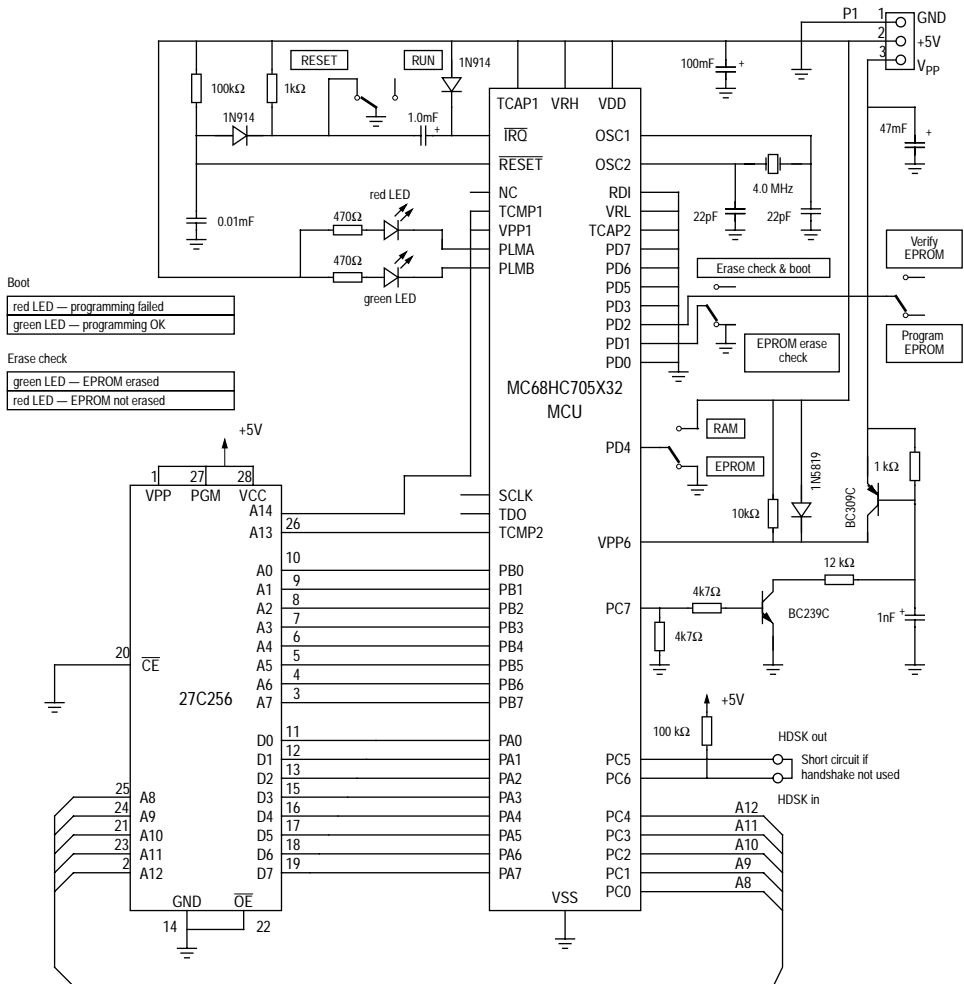

Figure B-6 EPROM parallel bootstrap schematic diagram

Warning: A minimum V_{PP6R} voltage must be applied to the VPP6 pin at all times, including power-on. Failure to do so could result in permanent damage to the device. Unless otherwise stated, EPROM programming is guaranteed at ambient temperature (25°C) only.

B.8.3 Serial RAM loader

This mode is similar to the RAM load/execute program for the MC68HC05X32 described in [Section 2.1.2.1](#), with the additional features listed below. [Table B-5](#) shows the entry conditions required for this mode.

If the first byte is less than \$B0, the bootloader behaves exactly as the MC68HC05X32, i.e. count byte followed by data stored in \$0050 to \$00FF. If the count byte is larger than RAM I (176 bytes) then the code continues to fill RAM II then RAM III. In this case the count byte is ignored and the program execution begins at \$0051 once the total RAM area is filled or if no data is received for 5 milliseconds.

The user must take care when using branches or jumps as his code will be relocated in RAM I, II and III. If the user intends to use the stack in his program, he should send NOP's to fill the desired stack area.

In the RAM bootloader mode, all interrupt vectors are mapped to pseudo-vectors in RAM (see [Table B-6](#)). This allows programmers to use their own service-routine addresses. Each pseudo-vector is allowed three bytes of space rather than the two bytes for normal vectors, because an explicit jump (JMP) opcode is needed to cause the desired jump to the users service-routine address.

Table B-6 Bootstrap vector targets in RAM

Vector targets in RAM	
SCI interrupt	\$0063
Timer overflow	\$0060
Timer output compare	\$005D
Timer input capture	\$005A
$\overline{\text{IRQ}}$	\$0057
SWI	\$0054

B.8.3.1 Jump to start of RAM (\$0051)

The Jump to start of RAM program will be executed then the device will be brought out of reset with PD2 and PD3 at '1' and PD4 at '0'.

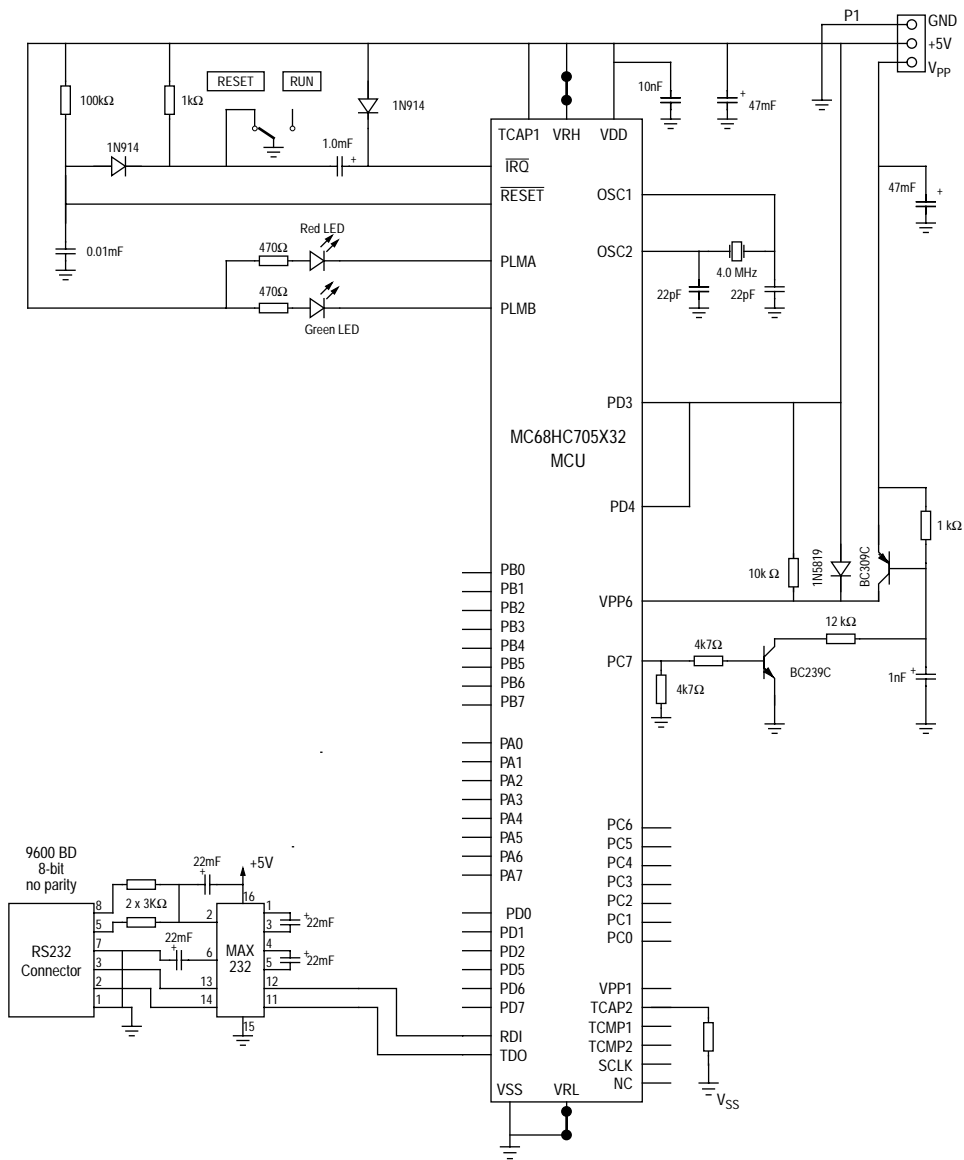

Figure B-7 RAM load and execute schematic diagram

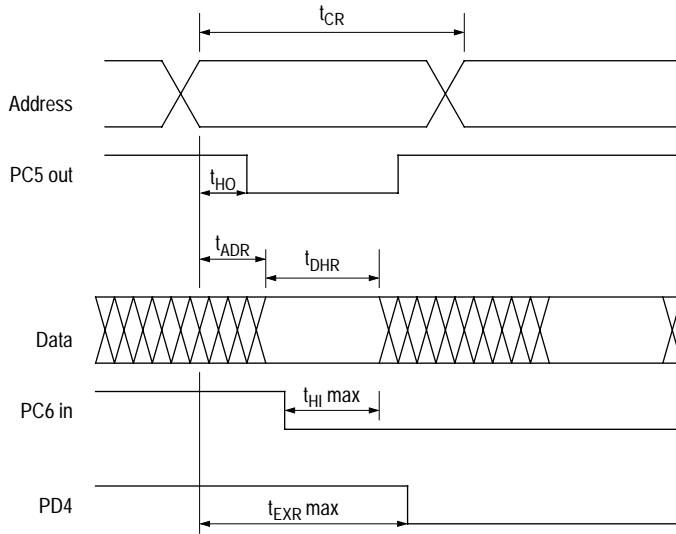

Figure B-8 Parallel RAM loader timing diagram

B.9 Electrical specifications

B.9.1 Maximum ratings

Table B-7 Maximum ratings

Rating	Symbol	Value	Unit
Supply voltage ⁽¹⁾	V_{DD}	- 0.5 to +7.0	V
Input voltage	V_{IN}	$V_{SS} - 0.5$ to $V_{DD} + 0.5$	V
Input voltage – Bootstrap mode (\overline{IRQ} pin only)	V_{IN}	$V_{SS} - 0.5$ to $2V_{DD} + 0.5$	V
Operating temperature range	T_A	T_L to T_H -40 to +125	°C
Storage temperature range	T_{STG}	- 65 to +150	°C
Current drain per pin ⁽²⁾ (Excluding VDD, VSS, VDD1 and VSS1)			
– Source	I_D	25	mA
– Sink	I_S	45	mA
External oscillator frequency	f_{OSC}	22	MHz

(1) All voltages are with respect to V_{SS} .

(2) Maximum current drain per pin is for one pin at a time, limited by an external resistor.

Note: This device contains circuitry designed to protect against damage due to high electrostatic voltages or electric fields. However, it is recommended that normal precautions be taken to avoid the application of any voltages higher than those given in the maximum ratings table to this high impedance circuit. For maximum reliability all unused inputs should be tied to either V_{SS} or V_{DD} .

B.9.2 DC electrical characteristics

Table B-8 DC electrical characteristics

($V_{DD} = 5.0 \text{ Vdc} \pm 10\%$, $V_{SS} = 0 \text{ Vdc}$, $T_A = -40^\circ\text{C}$ to $+125^\circ\text{C}$)

Characteristic ⁽¹⁾	Symbol	Min	Typ ⁽²⁾	Max	Unit
Output voltage $I_{LOAD} = -10 \mu\text{A}$ $I_{LOAD} = +10 \mu\text{A}$	V_{OH} V_{OL}	$V_{DD} - 0.1$ —	— —	— 0.1	V
Output high voltage ($I_{LOAD} = 0.8 \text{ mA}$) PA0-7, PB0-7, PC0-7, TCMP1, TCMP2, Output high voltage ($I_{LOAD} = 1.6 \text{ mA}$) TDO, SCLK, PLMA, PLMB Output high voltage ($I_{LOAD} = -300 \mu\text{A}$) OSC2	V_{OH} V_{OH} V_{OH}	$V_{DD} - 0.8$ $V_{DD} - 0.8$ $V_{DD} - 0.8$	$V_{DD} - 0.2$ $V_{DD} - 0.2$ $V_{DD} - 0.3$	— — —	V
Output low voltage ($I_{LOAD} = 1.6 \text{ mA}$) PA0-7, PB0-7, PC0-7, TCMP1, TCMP2, TDO, SCLK, PLMA, PLMB Output low voltage ($I_{LOAD} = 1.6 \text{ mA}$) RESET Output low voltage ($I_{LOAD} = -100 \mu\text{A}$) OSC2	V_{OL} V_{OL} V_{OL}	— — —	0.1 0.2 0.2	0.4 0.6 0.4	V
Input high voltage PA0-7, PB0-7, PC0-7, PD0-7, OSC1, \overline{IRQ} , RESET, TCAP1, TCAP2, RDI, CANE, MDS, NWOI	V_{IH}	$0.7V_{DD}$	—	V_{DD}	V
Input low voltage PA0-7, PB0-7, PC0-7, PD0-7, OSC1, \overline{IRQ} , RESET, TCAP1, TCAP2, RDI, CANE, MDS, NWOI	V_{IL}	V_{SS}	—	$0.2V_{DD}$	V
Can comparator I_{DD} (I_{DD1}) ⁽³⁾⁽⁴⁾⁽⁵⁾ Supply current in DIV2 mode RUN: CAN active ⁽⁶⁾ STOP: CAN active WAIT: CAN asleep ⁽⁷⁾ STOP: CAN asleep	I_{DD1} I_{DD1} I_{DD1} I_{DD1}	— — — —	360 360 32 10	900 900 100 30	μA μA μA μA
MCU I_{DD} ⁽³⁾⁽⁴⁾⁽⁸⁾ Supply current in DIV 2 mode RUN (SM = 0): CAN active RUN (SM = 1): CAN active WAIT (SM = 0): CAN active WAIT (SM = 1): CAN active WAIT (SM = 0): CAN asleep WAIT (SM = 1): CAN asleep STOP: CAN active STOP: CAN asleep	I_{DD} I_{DD} I_{DD} I_{DD} I_{DD} I_{DD} I_{DD} I_{DD}	— — — — — — — —	7 2.2 2.4 1.9 1.3 0.7 0.5 90	11.4 3.9 4.4 3.2 2.7 0.9 1.5 300	mA mA mA mA mA mA mA μA
MCU I_{DD} ⁽³⁾⁽⁵⁾⁽⁸⁾ Supply current RUN (SM = 0): CAN active RUN (SM = 1): CAN active WAIT (SM = 0): CAN active WAIT (SM = 1): CAN active WAIT (SM = 0): CAN asleep WAIT (SM = 1): CAN asleep STOP: CAN active STOP: CAN asleep	I_{DD} I_{DD} I_{DD} I_{DD} I_{DD} I_{DD} I_{DD} I_{DD}	— — — — — — — —	3.9 1.2 1.4 1.0 1.1 0.6 0.16 90	7 2.9 3.2 2.6 2 1.75 1.5 300	mA mA mA mA mA mA mA μA
High-Z leakage current PA0-7, PB0-7, PC0-7, TDO, RESET, SCLK	I_{IL}	—	± 0.2	± 1	μA

Table B-8 DC electrical characteristics (Continued)

($V_{DD} = 5.0 \text{ Vdc} \pm 10\%$, $V_{SS} = 0 \text{ Vdc}$, $T_A = -40^\circ\text{C}$ to $+125^\circ\text{C}$)

Characteristic ⁽¹⁾	Symbol	Min	Typ ⁽²⁾	Max	Unit
Input current OSC1= V_{DD} (OSC2= V_{SS})	I_{FH}	-10	—	—	μA
Input current OSC1= V_{SS} (OSC2= V_{DD})	I_{FL}	—	—	+10	μA
Input current IRQ, TCAP1, TCAP2, RDI, PDO/ANO-PD7/AN7 (channel not selected)	I_{IN}	—	± 0.2	± 1	μA
Capacitance Ports (as input or output), $\overline{\text{RESET}}$, TDO, SCLK IRQ, TCAP1, TCAP2, OSC1, RDI PDO/ANO-PD7/AN7 (A/D off) PDO/ANO-PD7/AN7 (A/D on)	C_{OUT} C_{IN} C_{IN} C_{IN}	— — — —	— — 12 22	12 8 — —	pF pF pF pF
DC injection current ⁽⁹⁾ Port A (PA0-PA7) Port B (PB0-PB7)	$ I_{INJ} $ $ I_{INJ} $	— —	— —	10 10	mA mA

- (1) All I_{DD} measurements taken with suitable decoupling capacitors across the power supply to suppress the transient switching currents inherent in CMOS designs (see Section 2).
- (2) Typical values are at mid point of voltage range and at 25°C only.
- (3) RUN and WAIT I_{DD} : measured using an external square-wave clock source, refer to Figure 2-6(c); all inputs 0.2 V from rail; no DC loads; maximum load on outputs 50pF (20pF on OSC2).
STOP/WAIT I_{DD} : all ports configured as inputs; $V_{IL} = 0.2 \text{ V}$ and $V_{IH} = V_{DD} - 0.2 \text{ V}$; STOP I_{DD} measured with $OSC1 = V_{DD}$; WAIT I_{DD} is affected linearly by the OSC2 capacitance.
- (4) $f_{OSC} = 8 \text{ MHz}$; $f_{BUS} = 4 \text{ MHz}$; $f_{CAN} = 4 \text{ MHz}$
- (5) $f_{OSC} = 4.4 \text{ MHz}$; $f_{BUS} = 2.2 \text{ MHz}$; $f_{CAN} = 2.2 \text{ MHz}$
- (6) These limits are also applicable under the following conditions:
MCU RUN mode/SLOW mode/CAN active
MCU WAIT mode/SLOW mode/CAN active
MCU WAIT mode/CAN active
- (7) These limits are also applicable under the following conditions:
MCU WAIT mode/SLOW mode/CAN asleep
- (8) These currents are the summation of the MCU current + CAN current ($I_{DD} + I_{DD1}$)
- (9) Current injection is guaranteed but not tested.
Functionality of the MCU is guaranteed during injection of dc current up to the maximum specified level.
The maximum specified current for each port is the sum of the magnitudes of the currents on each side of the individual port pins.
Some disturbance of the A/D accuracy is possible during an injection event and is dependent on board layout, power supply decoupling and reference voltage decoupling configurations.

B.9.3 EPROM electrical characteristics

Table B-9 EPROM electrical characteristics

($V_{DD} = 5.0 \text{ Vdc} \pm 10\%$, $V_{SS} = 0 \text{ Vdc}$, $T_A = -40^\circ\text{C}$ to $+125^\circ\text{C}$, $f_{MCU} \leq 4\text{MHz}$)

Characteristic	Symbol	Min	Typ ⁽¹⁾	Max	Unit
EPROM					
Absolute maximum voltage	$V_{PP6 \text{ max}}$	V_{DD}	—	18	V
Programming voltage	V_{PP6}	14.5	15	16	V
Programming current	I_{PP6}	—	50	64	mA
Read voltage ^(A)	V_{PP6R}	$V_{DD} - 0.35$	—	V_{DD}	V
Read voltage ^(B)	V_{PP6R}	$V_{DD} - 0.5$	—	V_{DD}	V
Read current	I_{PP6R}	—	100	150	μA
EPROM programming time	t_{PROG}	5	—	20	ms

(1) Typical values are at mid point of voltage range and at 25°C only.

(A) $F_{MCU} > 2.2 \text{ MHz}$

(B) $F_{MCU} \leq 2.2 \text{ MHz}$

Note: Use of programming times between 5ms and 20ms will not affect the product reliability.

B.9.4 Control timing

Table B-10 Control timing

($V_{DD} = 5.0 \text{ Vdc} \pm 10\%$, $V_{SS} = 0 \text{ Vdc}$, $T_A = -40^\circ\text{C}$ to $+125^\circ\text{C}$)

Characteristic	Symbol	Min	Max	Unit
Frequency of operation				
Oscillator frequency	f_{OSC}	0	22	MHz
MCAN module clock frequency	f_{CAN}	0	11	MHz
MCU bus frequency	f_{MCU}	0	4	MHz
Cycle time (see Figure 10-1)	t_{CYC}	455	—	ns
Crystal oscillator start-up time (see Figure 10-1)	t_{OXOV}	—	100	ms
Stop recovery start-up time (crystal oscillator)	t_{ILCH}		100	ms
A/D converter stabilization time	t_{ADON}		500	μs
External RESET input pulse width	t_{RL}	3.0	—	t_{CYC}
Power-on RESET output pulse width				
4064 cycle	t_{PORL}	4064	—	t_{CYC}
16 cycle	t_{PORL}	16	—	t_{CYC}
Watchdog RESET output pulse width	t_{DOGL}	1.5	—	t_{CYC}
Watchdog time-out	t_{DOG}	6144	7168	t_{CYC}
EEPROM byte erase time	t_{ERA}	10	10	ms
EEPROM byte program time ⁽¹⁾	t_{PROG}	10	10	ms
Timer (see Figure B-9)				
Resolution ⁽²⁾	t_{RESL}	4	—	t_{CYC}
Input capture pulse width	t_{TH}, t_{TL}	125	—	ns
Input capture pulse period	t_{TLTL}	— ⁽³⁾	—	t_{CYC}
Interrupt pulse width (edge-triggered)	t_{LIH}	125	—	ns
Interrupt pulse period	t_{LIL}	— ⁽⁴⁾	—	t_{CYC}
OSC1 pulse width	t_{OH}, t_{OL}	90	—	ns
Write/erase endurance ⁽⁵⁾⁽⁶⁾	—	10000		cycles
Data retention ⁽⁵⁾⁽⁶⁾	—	10		years

- (1) For bus frequencies less than 2 MHz, the internal RC oscillator should be used when programming the EEPROM.
- (2) Since a 2-bit prescaler in the timer must count four external cycles (t_{CYC}), this is the limiting factor in determining the timer resolution.
- (3) The minimum period t_{TLTL} should not be less than the number of cycle times it takes to execute the capture interrupt service routine plus 24 t_{CYC} .
- (4) The minimum period t_{LIL} should not be less than the number of cycle times it takes to execute the interrupt service routine plus 21 t_{CYC} .
- (5) At a temperature of 85°C.
- (6) Refer to Reliability Monitor Report (current quarterly issue) for current failure rate information.

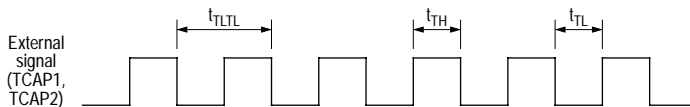

Figure B-9 Timer relationship

B.9.5 A/D converter characteristics

Table B-11 A/D characteristics

($V_{DD} = 5.0 \text{ Vdc} \pm 10\%$, $V_{SS} = 0 \text{ Vdc}$, $T_A = -40^\circ\text{C}$ to $+125^\circ\text{C}$)

Characteristic	Parameter	Min	Max	Unit
Resolution	Number of bits resolved by the A/D	8	—	Bit
Non-linearity	Max deviation from the best straight line through the A/D transfer characteristics ($V_{RH} = V_{DD}$ and $V_{RL} = 0\text{V}$)	—	± 0.5	LSB
Quantization error	Uncertainty due to converter resolution	—	± 0.5	LSB
Absolute accuracy	Difference between the actual input voltage and the full-scale equivalent of the binary code output code for all errors	—	± 1	LSB
Conversion range	Analog input voltage range	V_{RL}	V_{RH}	V
V_{RH}	Maximum analog reference voltage	V_{RL}	$V_{DD} + 0.1$	V
V_{RL}	Minimum analog reference voltage	$V_{SS} - 0.1$	V_{RH}	V
$\Delta V_R^{(1)}$	Minimum difference between V_{RH} and V_{RL}	3	—	V
Conversion time	Total time to perform a single analog to digital conversion a. External clock (OSC1, OSC2) b. Internal RC oscillator	— —	32 32	t_{CYC} μs
Monotonicity	Conversion result never decreases with an increase in input voltage and has no missing codes	GUARANTEED		
Zero input reading	Conversion result when $V_{IN} = V_{RL}$	00	—	Hex
Full scale reading	Conversion result when $V_{IN} = V_{RH}$	—	FF	Hex
Sample acquisition time	Analog input acquisition sampling a. External clock (OSC1, OSC2) b. Internal RC oscillator ⁽²⁾	— —	12 12	t_{CYC} μs
Sample/hold capacitance	Input capacitance on PD0/AN0–PD7/AN7	—	12	pF
Input leakage ⁽³⁾	Input leakage on A/D pins PD0/AN0–PD7/AN7, VRL, VRH	—	1	μA

(1) Performance verified down to 2.5V ΔV_R , but accuracy is tested and guaranteed at $\Delta V_R = 5\text{V} \pm 10\%$.

(2) Source impedances greater than 10k Ω will adversely affect internal charging time during input sampling.

(3) The external system error caused by input leakage current is approximately equal to the product of R source and input current. Input current to A/D channel will be dependent on external source impedance (see [Figure 9-2](#)).

B.9.6 MCAN bus interface DC electrical characteristics

Table B-12 MCAN bus interface DC electrical characteristics

($V_{DD} = 5.0 \text{ Vdc} \pm 10\%$, $V_{SS} = 0 \text{ Vdc}$, $T_A = -40^\circ\text{C}$ to $+125^\circ\text{C}$)

Characteristic	Symbol	Min	Max	Unit
MCAN bus input comparator: pins RX0 and RX1				
Input voltage	V_{IN}	0.5	$V_{DD} + 0.5$	V
Common mode range	C_{MR}	1.5	$V_{DD} - 1.5$	V
Latch-up trigger current ⁽¹⁾	I_{LT}	-100	+100	mA
Input offset voltage	V_{OFS}	-30	+30	mV
Hysteresis	V_{HYS}	1	22	mV
$V_{DD} \div 2$ generator: pin VDDH				
Output voltage difference to $V_{DD} \div 2$ for $-100 \mu\text{A} < I_{OUT} < +100 \mu\text{A}$	DV_{OUT}	-200	+200	mV
Output current	I_{OUT}	-100	+100	μA
Latch-up trigger current ¹	I_{LT}	-100	+100	mA
MCAN bus output driver: pins TX0 and TX1				
Source current per pin ($V_{OUT} = V_{DD} - 1.0\text{V}$)	I_{OH}	-10	—	mA
Sink current per pin ($V_{OUT} = 1.0\text{V}$)	I_{OL}	10	—	mA
Latch-up trigger current ¹	I_{LT}	-100	+100	mA

($V_{DD} = 5.0 \text{ Vdc} \pm 2\%$, $V_{SS} = 0 \text{ Vdc}$, $T_A = -40^\circ\text{C}$ to $+125^\circ\text{C}$)

Characteristic	Symbol	Min	Max	Unit
$V_{DD} \div 2$ generator: pin VDDH				
Output voltage difference to $V_{DD} \div 2$ for $-100 \mu\text{A} < I_{OUT} < +100 \mu\text{A}$	DV_{OUT}	-180	+180	mV

(1) Maximum DC current should comply with maximum ratings.

B.9.7 MCAN bus interface control timing characteristics

Table B-13 MCAN bus interface control timing characteristics

($4.5\text{V} \leq V_{DD} \leq 5.5\text{V}$, $V_{SS} = 0 \text{ Vdc}$, $T_A = -40^\circ\text{C}$ to $+125^\circ\text{C}$)

Characteristic	Symbol	Min	Max	Unit
MCAN bus output driver				
Rise and fall time ($C_{LOAD} = 100\text{pF}$)	T_{RF}	—	25	ns

THIS PAGE LEFT BLANK INTENTIONALLY

C

MC68HC05X32

High speed operation

The following table of electrical characteristics applies only to the MC68HC05X32 operating with a 4 MHz bus speed. For all other information relating to this device (except ordering information, which can be found in [Section 14](#)), please refer to [Appendix A](#).

C.1 DC electrical characteristics

Table C-1 DC electrical characteristics

($V_{DD} = 5.0 \text{ Vdc} \pm 10\%$, $V_{SS} = 0 \text{ Vdc}$, $T_A = -40^\circ\text{C}$ to $+125^\circ\text{C}$)

Characteristic ⁽¹⁾	Symbol	Min	Typ ⁽²⁾	Max	Unit
MCU I_{DD} ⁽³⁾⁽⁴⁾⁽⁵⁾					
Supply current					
RUN (SM = 0): CAN active	I_{DD}	—	5.8	11	mA
RUN (SM = 1): CAN active	I_{DD}	—	2.1	5.5	mA
WAIT (SM = 0): CAN active	I_{DD}	—	2.6	5.5	mA
WAIT (SM = 1): CAN active	I_{DD}	—	2	5	mA
WAIT (SM = 0): CAN asleep	I_{DD}	—	1.1	2.2	mA
WAIT (SM = 1): CAN asleep	I_{DD}	—	0.6	1.2	mA
STOP: CAN active	I_{DD}	—	0.5	1.5	mA
STOP: CAN asleep	I_{DD}	—	90	300	μA

(1) All I_{DD} measurements taken with suitable decoupling capacitors across the power supply to suppress the transient switching currents inherent in CMOS designs (see Section 2).

(2) Typical values are at mid point of voltage range and at 25°C only.

(3) RUN and WAIT I_{DD} : measured using an external square-wave clock source, refer to [Figure 2-6\(c\)](#); all inputs 0.2 V from rail; no DC loads; maximum load on outputs 50pF (20pF on OSC2).

STOP/WAIT I_{DD} : all ports configured as inputs; $V_{IL} = 0.2 \text{ V}$ and $V_{IH} = V_{DD} - 0.2 \text{ V}$; STOP I_{DD} measured with OSC1 = V_{DD} . WAIT I_{DD} is affected linearly by the OSC2 capacitance.

(4) $f_{OSC} = 8 \text{ MHz}$; $f_{BUS} = 4 \text{ MHz}$; $f_{CAN} = 4 \text{ MHz}$.

(5) These currents are the summation of the MCU current + CAN current ($I_{DD} + I_{DD1}$).

Note: The 4MHz bus frequency is achievable only in divide by 2 and divide by 4 modes. It is not possible in divide by 10 mode.

C.2 Control Timing

Table C-2 Control timing

($V_{DD} = 5.0 \text{ Vdc} \pm 10\%$, $V_{SS} = 0 \text{ Vdc}$, $T_A = -40^\circ\text{C}$ to $+125^\circ\text{C}$)

Characteristic	Symbol	Min	Max	Unit
Frequency of operation				
Oscillator frequency	f_{OSC}	0	16	MHz
MCAN module clock frequency	f_{CAN}	0	4	MHz
MCU bus frequency	f_{MCU}	0	4	MHz
Cycle time (see Figure 10-1)	t_{CYC}	250	—	ns

GLOSSARY

This section contains abbreviations and specialist words used in this data sheet and throughout the industry. Further information on many of the terms may be gleaned from Motorola's *M68HC11 Reference Manual*, *M68HC11RM/AD*, or from a variety of standard electronics text books.

\$xxxx	The digits following the '\$' are in hexadecimal format.
%xxxx	The digits following the '%' are in binary format.
A/D, ADC	Analog-to-digital (converter).
Bootstrap mode	In this mode the device automatically loads its internal memory from an external source on reset and then allows this program to be executed.
Byte	Eight bits.
CAN	Controller area network.
CCR	Condition codes register; an integral part of the CPU.
CERQUAD	A ceramic package type, principally used for EPROM and high temperature devices.
Clear	'0' — the logic zero state; the opposite of 'set'.
CMOS	Complementary metal oxide semiconductor. A semiconductor technology chosen for its low power consumption and good noise immunity.
COP	Computer operating properly. <i>aka</i> 'watchdog'. This circuit is used to detect device runaway and provide a means for restoring correct operation.
CPU	Central processing unit.
D/A, DAC	Digital-to-analog (converter).
EEPROM	Electrically erasable programmable read only memory. <i>aka</i> 'EEROM'.
EPROM	Erasable programmable read only memory. This type of memory requires exposure to ultra-violet wavelengths in order to erase previous data. <i>aka</i> 'PROM'.
ESD	Electrostatic discharge.

Expanded mode	In this mode the internal address and data bus lines are connected to external pins. This enables the device to be used in much more complex systems, where there is a need for external memory for example.
EVS	Evaluation system. One of the range of platforms provided by Motorola for evaluation and emulation of their devices.
HCMOS	High-density complementary metal oxide semiconductor. A semiconductor technology chosen for its low power consumption and good noise immunity.
I/O	Input/output; used to describe a bidirectional pin or function.
Input capture	(IC) This is a function provided by the timing system, whereby an external event is 'captured' by storing the value of a counter at the instant the event is detected.
Interrupt	This refers to an asynchronous external event and the handling of it by the MCU. The external event is detected by the MCU and causes a predetermined action to occur.
$\overline{\text{IRQ}}$	Interrupt request. The overline indicates that this is an active-low signal format.
K byte	A kilo-byte (of memory); 1024 bytes.
LCD	Liquid crystal display.
LSB	Least significant byte.
M68HC05	Motorola's family of 8-bit MCUs.
MCU	Microcontroller unit.
MI BUS	Motorola interconnect bus. A single wire, medium speed serial communications protocol.
MSB	Most significant byte.
Nibble	Half a byte; four bits.
NRZ	Non-return to zero.
Opcode	The opcode is a byte which identifies the particular instruction and operating mode to the CPU.
Operand	The operand is a byte containing information the CPU needs to execute a particular instruction.
Output compare	(OC) This is a function provided by the timing system, whereby an external event is generated when an internal counter value matches a predefined value.
PLCC	Plastic leaded chip carrier package.
PLL	Phase-locked loop circuit. This provides a method of frequency multiplication, to enable the use of a low frequency crystal in a high frequency circuit.

Pull-down, pull-up	These terms refer to resistors, sometimes internal to the device, which are permanently connected to either ground or V_{DD} .
PWM	Pulse width modulation. This term is used to describe a technique where the width of the high and low periods of a waveform is varied, usually to enable a representation of an analog value.
QFP	Quad flat pack package.
RAM	Random access memory. Fast read and write, but contents are lost when the power is removed.
RFI	Radio frequency interference.
RTI	Real-time interrupt.
ROM	Read-only memory. This type of memory is programmed during device manufacture and cannot subsequently be altered.
RS-232C	A standard serial communications protocol.
SAR	Successive approximation register.
SCI	Serial communications interface.
Set	'1' — the logic one state; the opposite of 'clear'.
Silicon glen	An area in the central belt of Scotland, so called because of the concentration of semiconductor manufacturers and users found there.
Single chip mode	In this mode the device functions as a self contained unit, requiring only I/O devices to complete a system.
SPI	Serial peripheral interface.
Test mode	This mode is intended for factory testing.
TTL	Transistor-transistor logic.
UART	Universal asynchronous receiver transmitter.
VCO	Voltage controlled oscillator.
Watchdog	see 'COP'.
Wired-OR	A means of connecting outputs together such that the resulting composite output state is the logical OR of the state of the individual outputs.
Word	Two bytes; 16 bits.
XIRQ	Non-maskable interrupt request. The overline indicates that this has an active-low signal format.

THIS PAGE LEFT BLANK INTENTIONALLY

INDEX

In this index numeric entries are placed first; page references in *italics* indicate that the reference is to a figure.

64-pin QFP mechanical drawing 13-2
64-pin QFP pinout 13-1

A

A – accumulator 11-1
A/D converter
 ADSTAT 4-5
 block diagram 9-2
 clock selection 9-4
AC7-AC0 bits in CACC 5-13
ADDATA – A/D result data register 9-3
addressing modes 11-11–11-13
ADON bit in ADSTAT 4-5, 9-5
ADRC bit in ADSTAT 9-4
ADSTAT – A/D status/control register 4-5, 9-4
 ADON – A/D converter on bit 4-5, 9-5
 ADRC – A/D RC oscillator control bit 9-4
 CH3-CH0 – A/D channel selection bits 9-5
 COCO – continuous conversion bit 9-4
alternate counter register 6-3
AM0-AM7 bits in CACM 5-14
AT bit in CCOM 5-9

B

BAUD – baud rate register 7-18
 SCP1, SCP0 – serial prescaler select bits 7-18
 SCR2, SCR1, SCR0 – SCI rate select bits 7-19
 SCT2, SCT1, SCT0 – SCI rate select bits 7-18
baud rate selection 7-20
biphase mode 5-18
bit set/clear addressing mode 11-13
bit test and branch addressing mode 11-13
bit time calculation 5-17
block diagrams
 A/D converter 9-2
 COP watchdog system 10-4
 MC68HC05X16 1-4
 MC68HC05X32 A-2
 MC68HC705X32 B-3

MCAN module 5-1
PLM system 8-1
programmable timer 6-2
SCI 7-2
 slow mode divider 2-10
BRP5-BRP0 bits in CBT0 5-15
BS bit in CSTAT 5-10

C

CACC – MCAN acceptance code register 5-13
 AC7-AC0 – acceptance code bits 5-13
CACM – MCAN acceptance mask register 5-14
 AM0-AM7 – acceptance mask bits 5-14
CAF bit in EEPROM control B-8
CAN – see MCAN
CANE B-2
C-bit in CCR 11-3
CBT0 – MCAN bus timing register 0 5-14
 BRP5-BRP0 – baud rate prescaler bits 5-15
 SJW1, SJW0 – synchronization jump width bits 5-14
CBT1 – MCAN bus timing register 1 5-16
 SAMP – sampling bit 5-16
 TSEG22-TSEG10 – time segment bits 5-16
CCNTRL – MCAN control register 5-6
 EIE – error interrupt enable bit 5-6
 MODE – undefined mode bit 5-6
 OIE – overrun interrupt enable bit 5-6
 RIE – receive interrupt enable bit 5-7
 RR – reset request bit 5-7
 SPD – speed mode bit 5-6
 TIE – transmit interrupt enable bit 5-6
CCOM – MCAN command register 5-7
 AT – abort transmission bit 5-9
 COMPSEL – comparator selector bit 5-8
 COS – clear overrun status bit 5-9
 RRB – release receive buffer bit 5-9
 RX0, RX1 – receive pin bits 5-8
 SLEEP – go to sleep bit 5-8
 TR – transmission request bit 5-9
CCR – condition code register 11-2
ceramic resonator 2-13
CH3-CH0 bits in ADSTAT 9-5

CINT – MCAN interrupt register 5-12
 EIF – error interrupt flag 5-12
 OIF – overrun interrupt flag 5-12
 RIF – receive interrupt flag 5-13
 TIF – transmit interrupt flag 5-12
 WIF – wake-up interrupt flag 5-12
 CIRQ 10-11
 clocks – see oscillator clock
 COCNTRL – MCAN output control register 5-18
 OCM1, OCM0 – output control mode bits 5-18
 COCO bit in ADSTAT 9-4
 COMPSEL bit in CCOM 5-8
 COP 10-3
 block diagram 10-4
 COS bit in CCOM 5-9
 counter 6-1
 alternate counter register 6-3
 counter register 6-3
 CPHA bit in SCCR1 7-12
 CPOL bit in SCCR1 7-12
 CPU
 A – accumulator 11-1
 addressing modes 11-11–11-13
 CCR – condition code register 11-2
 instruction set 11-3–11-10
 PC – program counter 11-2
 programming model 11-1
 SP – stack pointer 11-2
 stacking order 11-2
 X – index register 11-2
 crystal 2-13
 CSTAT – MCAN status register 5-10
 BS – bus status bit 5-10
 DO – data overrun bit 5-11
 ES – error status bit 5-10
 RBS – receive buffer status bit 5-11
 RS – receive status bit 5-10
 TBA – transmit buffer access bit 5-11
 TCS – transmission complete status bit 5-11
 TS – transmit status bit 5-10

D

DB7-DB0 bits in TDS 5-21
 direct addressing mode 11-11
 DIV2, DIV8 bits in MOR B-12
 DLC3-DLC0 bits in TRTDL 5-20
 DO bit in CSTAT 5-11

E

E1ERA bit in EEPROM control 3-5
 E1LAT bit in EEPROM control 3-5
 E1PGM bit in EEPROM control 3-5
 E6LAT bit in EEPROM control B-9
 E6PGM bit in EEPROM control B-9
 ECLK bit in EEPROM control 3-5, 4-3

EE1P bit in OPTR 3-8, B-11

EEPROM

erase operation 3-6
 programming operation 3-7
 read operation 3-6
 EEPROM control register 3-4, B-8
 CAF – MCAN asleep flag B-8
 E1ERA – erase/programming bit 3-5
 E1LAT – programming latch enable bit 3-5
 E1PGM – charge pump enable/disable bit 3-5
 E6LAT – EPROM program latch enable bit B-9
 E6PGM – EPROM program enable bit B-9
 ECLK – external clock option bit 3-5, 4-3
 WOIE – wired-OR interrupt enable bit B-8

EIE bit in CCNTRL 5-6

EIF bit in CINT 5-12

EPROM

MOR B-12
 program operation B-8
 read operation B-7

ES bit in CSTAT 5-10

extended addressing mode 11-12

external clock 2-13

F

FE bit in SCSR 7-17

flow charts

interrupts 10-8
 self check mode (MC68HC05X16) 2-2
 STOP and WAIT 2-9

FOLV2, FOLV1 bits in TCR 6-5

H

H-bit in CCR 11-2

I

I-bit in CCR 11-3

ICF1, ICF2 bits in TSR 6-6

ICIE bit in TCR 6-4

ICR1, ICR2 – input capture registers 6-7

ID10-ID3 bits in TBI 5-20

ID2-ID0 bits in TRTDL 5-20

IDLE bit in SCSR 7-16

IEDG1 bit in TCR 6-5

ILIE bit in SCCR2 7-14

immediate addressing mode 11-11

indexed addressing modes 11-12

inherent addressing mode 11-11

input capture 6-7

instruction set 11-3–11-10

 tables of instructions 11-5–11-10

INTE bit in Miscellaneous 3-11, 10-10

interrupts

- CIRQ 10-11
- flow chart 10-8
- $\overline{\text{IRQ}}$ 10-11
- maskable 10-9
- nonmaskable 10-9
- priorities 10-9
- programmable timer 10-12
- SCI 10-12
- SWI 10-9
- WOI 10-11
- INTP, INTN bits in Miscellaneous 3-11, 10-10
- $\overline{\text{IRQ}}$ 2-11, 10-11

L

- LBCL bit in SCCR1 7-13
- low power modes 2-3
 - SLOW 2-8
 - WAIT 2-7

M

- M bit in SCCR1 7-11
- mask options
 - MC68HC05X16 1-3
- MC68HC05X16
 - block diagram 1-4
 - mask options 1-3
 - memory map 3-2
 - register outline 3-9
- MC68HC05X32
 - block diagram A-2
 - memory map A-3
 - register outline A-5
- MC68HC705X32
 - block diagram B-3
 - memory map B-5
 - register outline B-4
- MCAN
 - biphase mode 5-18
 - block diagram 5-1
 - CANE B-2
 - electrical characteristics 12-6, A-11, B-29
 - memory map 3-3, 5-5
 - normal mode 1 5-19
 - normal mode 2 5-19
 - oscillator block diagram 5-15
 - output control bits 5-19
 - RBF 5-4
 - register outline 3-10
 - single wire operation 5-24
 - SLEEP 5-24
 - TBF 5-4
- MDS 2-12
- mechanical drawings
 - 64-pin QFP 13-2
- memory

- EEPROM (MC68HC05X16) 3-4
- EPROM (MC68HC705X32) B-7
- MCAN memory map 3-3, 5-5
- memory map (MC68HC05X16) 3-2
- memory map (MC68HC05X32) A-3
- memory map (MC68HC705X32) B-5
- RAM (MC68HC05X16) 3-1
- ROM (MC68HC05X16) 3-1
- self-check ROM (MC68HC05X16) 3-3
- Miscellaneous register 2-10, 3-11, 8-3
 - INTE – external interrupt enable bit 3-11, 10-10
 - INTP, INTN – external interrupt sensitivity bits 10-10
 - INTP, INTN – interrupt sensitivity bits 3-11
 - POR – power-on reset bit 3-11, 10-2
 - SFA, SFB – slow or fast mode selection bits 3-11, 8-3
 - SM – slow mode selection bit 3-12, 8-3
 - SM slow mode selection bit 2-10
 - WDOG – watchdog enable/disable bit 3-12, 10-4
- MODE bit in CCNTRL 5-6
- modes of operation
 - jump to any address 2-3
 - low power modes 2-3
 - self-check mode 2-2
 - serial RAM loader 2-3
 - single-chip mode 2-1
- MOR – mask option register B-12
 - DIV2, DIV8 – clock divide ratio select bits B-12
 - PBPD, PCPD – port B and C pull-down bits B-13
 - RTIM – reset time bit B-12
 - RWAT – watchdog after reset bit B-12
 - WOI – wired-OR interrupt enable bit B-12
 - WWAT – watchdog during WAIT bit B-13

N

- N-bit in CCR 11-3
- NF bit in SCSR 7-17
- normal mode 1 5-19
- normal mode 2 5-19
- NWOI 2-16

O

- OCIE bit in TCR 6-4
- OCM1, OCM0 bits in COCNTRL 5-18
- OCR1, OCR2 – output compare registers 6-9
- OIE bit in CCNTRL 5-6
- OIF bit in CINT 5-12
- OLV2, OLV1 bits in TCR 6-5
- OPTR – EEPROM options register B-11
 - EE1P – EEPROM protect bit B-11
 - SEC – secure bit B-11
- OPTR – options register 3-7
 - EE1P – EEPROM protect bit 3-8
 - SEC – security bit 3-8
- OR bit in SCSR 7-17
- order numbers 14-1

OSC1, OSC2 2-13
oscillator clock
 ceramic resonator 2-13
 crystal 2-13
 external clock 2-13
 OSC1, OSC2 2-13
output compare 6-9

P

PA0–7, PB0–7, PC0–7 2-16
PBPD, PCPD bits in MOR B-13
PC – program counter 11-2
PDO/AN0–PD7/AN7 2-16
pinouts
 64-pin QFP 13-1
pins
 CANE B-2
 IRQ 2-11
 MDS 2-12
 NWOI 2-16
 OSC1, OSC2 2-13
 PA0–7, PB0–7, PC0–7 2-16
 PDO/AN0–PD7/AN7 2-16
 PLMA, PLMB 2-15
 RDI 2-12, 7-6
 RESET 2-11, 10-3
 RX0, RX1 2-17
 SCLK 2-13
 TCAP1, TCAP2 2-12
 TCMP1, TCMP2 2-12
 TDO 2-12
 TX0, TX1 2-17
 VDD, VSS 2-11
 VDD1, VSS1 2-17
 VDDH 2-17
 VPP1 2-16
 VPP6 B-2
 VRH 2-16
 VRL 2-16
PLM 6-11
 block diagram 8-1
 clock selection 8-4
 Miscellaneous register 8-3
PLMA, PLMB – pulse length modulation registers 8-2
PLMA, PLMB pins 2-15
POR bit in Miscellaneous 3-11, 10-2
ports
 data direction registers 4-6
 data registers 4-4
 logic levels 4-7
 port A 4-2
 port B 4-2
 port C 4-3
 port D 4-4
power-on reset 10-2
programmable timer
 block diagram 6-2
 counter 6-1

ICR1, ICR2 6-7
OCR1, OCR2 6-9
PLM 6-11
 software force compare 6-11
TCR 6-4
 timing diagrams 6-12
TSR 6-6
pulse length modulation – see PLM

R

R8 bit in SCCR1 7-11
RBF – receive buffer 5-4
RBI – receive buffer identifier register 5-21
RBS bit in CSTAT 5-11
RDI – receive data in 2-12, 7-6
RDRF bit in SCSR 7-16
RDS – receive data segment registers 5-22
RE bit in SCCR2 7-15
receiver wake-up 7-5
register outline
 MC68HC05X16 3-9
 MC68HC05X32 A-5
 MC68HC705X32 B-4
 MCAN 3-10
relative addressing mode 11-13
RESET 2-11, 10-3
resets
 COP 10-3
 power-on 10-2
 RESET pin 2-11, 10-3
 timing diagram 10-1
RIE bit in CCNTRL 5-7
RIE bit in SCCR2 7-14
RIF bit in CINT 5-13
ROM verification units 14-2
RR bit in CCNTRL 5-7
RRB bit in CCOM 5-9
RRTDL – transmission request/DLC register 5-22
RS bit in CSTAT 5-10
RTIM bit in MOR B-12
RTR bit in TRTDL 5-20
RVU 14-2
RWAT bit in MOR B-12
RWU bit in SCCR2 7-15
RX0, RX1 bits in CCOM 5-8
RX0, RX1 pins 2-17

S

SAMP bit in CBT1 5-16
SBK bit in SCCR2 7-15
SCCR1 – serial communications control register 1 7-10
 CPHA – clock phase 7-12
 CPOL – clock polarity bit 7-12
 LBCL – last bit clock 7-13
M – mode (select character format) 7-11

- R8 – receive data bit 8 7-11
- T8 – transmit data bit 8 7-11
- WAKE – wake-up mode select bit 7-11
- SCCR2 – serial communications control register 2 7-14
 - ILIE – idle line interrupt enable 7-14
 - RE – receiver enable 7-15
 - RIE – receiver interrupt enable 7-14
 - RWU – receiver wake-up 7-15
 - SBK – send break 7-15
 - TCIE – transmit complete interrupt enable 7-14
 - TE – transmitter enable 7-14
 - TIE – transmit interrupt enable 7-14
- SCDR – serial communications data register 7-10
- SCI
 - baud rate selection 7-20
 - block diagram 7-2
 - data format 7-5
 - receiver wake-up 7-5
 - start bit detection 7-6
 - timing diagrams 7-12
- SCLK 2-13
- SCP1, SCP0 bits in BAUD 7-18
- SCR2, SCR1, SCR0 bits in BAUD 7-19
- SCSR – serial communications status register 7-16
 - FE – framing error flag 7-17
 - IDLE – idle line detected flag 7-16
 - NF – noise error flag 7-17
 - OR – overrun error flag 7-17
 - RDRF – receive data register full flag 7-16
 - TC – transmit complete flag 7-16
 - TDRE – transmit data register empty flag 7-16
- SCT2, SCT1, SCT0 bits in BAUD 7-18
- SEC bit in OPTR 3-8, B-11
- self-check mode 2-2
- SFA, SFB bits in Miscellaneous 3-11, 8-3
- single-chip mode 2-1
- SJW1, SJW0 bits in CBT0 5-14
- SLEEP 5-24
- SLEEP bit in CCOM 5-8
- SLOW 2-8
- SM bit in Miscellaneous 2-10, 3-12, 8-3
- software force compare 6-11
- SP – stack pointer 11-2
- SPD bit in CCNTRL 5-6

T

- T8 bit in SCCR1 7-11
- TBA bit in CSTAT 5-11
- TBF – transmit buffer 5-4
- TBI – transmit buffer identifier register 5-20
 - ID10-ID3 – identifier bits 5-20
- TC bit in SCSR 7-16
- TCAP1, TCAP2 2-12
- TCIE bit in SCCR2 7-14
- TCMP1, TCMP2 2-12
- TCR – timer control register 6-4
 - FOLV2, FOLV1 – force output compare bits 6-5
 - ICIE – input capture interrupt enable 6-4

- IEDG1 – input edge bit 6-5
- OCIE – output compare interrupt enable 6-4
- OLV2, OLV1 – output level bits 6-5
- TOIE – timer overflow interrupt enable 6-4
- TCS bit in CSTAT 5-11
- TDO
 - SCI transmit data out 7-8
- TDO – transmit data out 2-12
- TDRE bit in SCSR 7-16
- TDS – transmit data segment registers 5-21
 - DB7-DB0 – data bits 5-21
- TE bit in SCCR2 7-14
- TIE bit in CCNTRL 5-6
- TIE bit in SCCR2 7-14
- TIF bit in CINT 5-12
- timing diagrams
 - ECLK 4-3
 - programmable timer 6-12
 - reset 10-1
 - SCI data clock 7-12
- TOF bit in TSR 6-6
- TOIE bit in TCR 6-4
- TR bit in CCOM 5-9
- TRTDL – transmission request/DLC register 5-20
 - DLC3-DLC0 – data length code bits 5-20
 - ID2-ID0 – identifier bits 5-20
 - RTR – remote transmission request 5-20
- TS bit in CSTAT 5-10
- TSEG22-TSEG10 bits in CBT1 5-16
- TSR – timer status register 6-6
 - ICF1, ICF2 – input capture flags 6-6
 - OCF1, OCF2 – output compare flags 6-6
 - TOF – timer overflow status flag 6-6
- TX0, TX1 2-17

V

- VDD, VSS 2-11
- VDD1, VSS1 2-17
- VDDH 2-17
- VPP1 2-16
- VPP6 B-2
- VRH 2-16
- VRL 2-16

W

- WAIT 2-7
- WAKE bit in SCCR1 7-11
- watchdog – see COP
- WDOG bit in Miscellaneous 3-12, 10-4
- WIF bit in CINT 5-12
- wired-OR interrupt – see WOI
- WOI 10-11
- WOI bit in MOR B-12
- WOIE bit in EEPROM control B-8
- WWAT bit in MOR B-13

X

X – index register 11-2

Z

Z-bit in CCR 11-3

CUSTOMER FEEDBACK QUESTIONNAIRE (MC68HC05X16/D)

Motorola wishes to continue to improve the quality of its documentation. We would welcome your feedback on the publication you have just received. Having used the document, please complete this card (or a photocopy of it, if you prefer).

1. How would you rate the quality of the document? Check one box in each category.

	Excellent			Poor		Excellent			Poor
Organization	<input type="checkbox"/>	<input type="checkbox"/>	<input type="checkbox"/>	<input type="checkbox"/>	Tables	<input type="checkbox"/>	<input type="checkbox"/>	<input type="checkbox"/>	<input type="checkbox"/>
Readability	<input type="checkbox"/>	<input type="checkbox"/>	<input type="checkbox"/>	<input type="checkbox"/>	Table of contents	<input type="checkbox"/>	<input type="checkbox"/>	<input type="checkbox"/>	<input type="checkbox"/>
Understandability	<input type="checkbox"/>	<input type="checkbox"/>	<input type="checkbox"/>	<input type="checkbox"/>	Index	<input type="checkbox"/>	<input type="checkbox"/>	<input type="checkbox"/>	<input type="checkbox"/>
Accuracy	<input type="checkbox"/>	<input type="checkbox"/>	<input type="checkbox"/>	<input type="checkbox"/>	Page size/binding	<input type="checkbox"/>	<input type="checkbox"/>	<input type="checkbox"/>	<input type="checkbox"/>
Illustrations	<input type="checkbox"/>	<input type="checkbox"/>	<input type="checkbox"/>	<input type="checkbox"/>	Overall impression	<input type="checkbox"/>	<input type="checkbox"/>	<input type="checkbox"/>	<input type="checkbox"/>

Comments: _____

2. What is your intended use for this document? If more than one option applies, please rank them (1, 2, 3).

Selection of device for new application	<input type="checkbox"/>				Other <input type="checkbox"/> Please specify: _____
System design	<input type="checkbox"/>				_____
Training purposes	<input type="checkbox"/>				_____

3. How well does this manual enable you to perform the task(s) outlined in question 2?

	Completely		Not at all		Comments: _____
	<input type="checkbox"/>	<input type="checkbox"/>	<input type="checkbox"/>	<input type="checkbox"/>	_____

4. How easy is it to find the information you are looking for?

	Easy		Difficult		Comments: _____
	<input type="checkbox"/>	<input type="checkbox"/>	<input type="checkbox"/>	<input type="checkbox"/>	_____

5. Is the level of technical detail in the following sections sufficient to allow you to understand how the device functions?

	Too little detail			Too much detail	
SECTION 1 INTRODUCTION	<input type="checkbox"/>	<input type="checkbox"/>	<input type="checkbox"/>	<input type="checkbox"/>	<input type="checkbox"/>
SECTION 2 MODES OF OPERATION AND PIN DESCRIPTIONS	<input type="checkbox"/>	<input type="checkbox"/>	<input type="checkbox"/>	<input type="checkbox"/>	<input type="checkbox"/>
SECTION 3 MEMORY AND REGISTERS	<input type="checkbox"/>	<input type="checkbox"/>	<input type="checkbox"/>	<input type="checkbox"/>	<input type="checkbox"/>
SECTION 4 INPUT/OUTPUT PORTS	<input type="checkbox"/>	<input type="checkbox"/>	<input type="checkbox"/>	<input type="checkbox"/>	<input type="checkbox"/>
SECTION 5 MOTOROLA CAN MODULE (MCAN)	<input type="checkbox"/>	<input type="checkbox"/>	<input type="checkbox"/>	<input type="checkbox"/>	<input type="checkbox"/>
SECTION 6 PROGRAMMABLE TIMER	<input type="checkbox"/>	<input type="checkbox"/>	<input type="checkbox"/>	<input type="checkbox"/>	<input type="checkbox"/>
SECTION 7 SERIAL COMMUNICATIONS INTERFACE	<input type="checkbox"/>	<input type="checkbox"/>	<input type="checkbox"/>	<input type="checkbox"/>	<input type="checkbox"/>
SECTION 8 PULSE LENGTH D/A CONVERTERS	<input type="checkbox"/>	<input type="checkbox"/>	<input type="checkbox"/>	<input type="checkbox"/>	<input type="checkbox"/>
SECTION 9 ANALOG TO DIGITAL CONVERTER	<input type="checkbox"/>	<input type="checkbox"/>	<input type="checkbox"/>	<input type="checkbox"/>	<input type="checkbox"/>
SECTION 10 RESETS AND INTERRUPTS	<input type="checkbox"/>	<input type="checkbox"/>	<input type="checkbox"/>	<input type="checkbox"/>	<input type="checkbox"/>
SECTION 11 CPU CORE AND INSTRUCTION SET	<input type="checkbox"/>	<input type="checkbox"/>	<input type="checkbox"/>	<input type="checkbox"/>	<input type="checkbox"/>
SECTION 12 ELECTRICAL SPECIFICATIONS	<input type="checkbox"/>	<input type="checkbox"/>	<input type="checkbox"/>	<input type="checkbox"/>	<input type="checkbox"/>
SECTION 13 MECHANICAL DATA	<input type="checkbox"/>	<input type="checkbox"/>	<input type="checkbox"/>	<input type="checkbox"/>	<input type="checkbox"/>
SECTION 14 ORDERING INFORMATION	<input type="checkbox"/>	<input type="checkbox"/>	<input type="checkbox"/>	<input type="checkbox"/>	<input type="checkbox"/>
SECTION 15 APPENDICES	<input type="checkbox"/>	<input type="checkbox"/>	<input type="checkbox"/>	<input type="checkbox"/>	<input type="checkbox"/>

Comments: _____

6. Have you found any errors? If so, please comment: _____

7. From your point of view, is anything missing from the document? If so, please say what: _____

- Cut along this line to remove -





8. How could we improve this document? _____

9. How would you rate Motorola's documentation?

	Excellent	Poor
- In general	<input type="checkbox"/>	<input type="checkbox"/>
- Against other semiconductor suppliers	<input type="checkbox"/>	<input type="checkbox"/>

10. Which semiconductor manufacturer provides the best technical documentation? _____

11. Which company (in any field) provides the best technical documentation? _____

12. How many years have you worked with microprocessors?
 Less than 1 year 1-3 years 3-5 years More than 5 years

- Second fold back along this line -

**By air mail
Par avion**
 IBRS NUMBER PHQ-B/207/G
 CCRI NUMERO PHQ-B/207/G

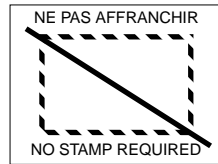

**REPONSE PAYEE
GRANDE-BRETAGNE**

Motorola Ltd.,
 Colvilles Road,
 Kelvin Industrial Estate,
 EAST KILBRIDE,
 G75 8BR.
 GREAT BRITAIN.



F.A.O. Technical Publications Manager
 (re: MC68HC05X16/D)

- First fold back along this line -

- Cut along this line to remove -

- Third fold back along this line -

13. Currently there is some discussion in the semiconductor industry regarding a move towards providing data sheets in electronic form. If you have any opinion on this subject, please comment. _____

14. We would be grateful if you would supply the following information (at your discretion), or attach your card.

Name: _____ Phone No: _____
 Position: _____ FAX No: _____
 Department: _____
 Company: _____
 Address: _____

*Thank you for helping us improve our documentation,
 Graham Forbes, Technical Publications Manager, Motorola Ltd., Scotland.*

- Finally, tuck this edge into opposite flap -

INTRODUCTION	1
MODES OF OPERATION AND PIN DESCRIPTIONS	2
MEMORY AND REGISTERS	3
INPUT/OUTPUT PORTS	4
MOTOROLA CAN MODULE (MCAN)	5
PROGRAMMABLE TIMER	6
SERIAL COMMUNICATIONS INTERFACE	7
PULSE LENGTH D/A CONVERTERS	8
ANALOG TO DIGITAL CONVERTER	9
RESETS AND INTERRUPTS	10
CPU CORE AND INSTRUCTION SET	11
ELECTRICAL SPECIFICATIONS	12
MECHANICAL DATA	13
ORDERING INFORMATION	14
APPENDICES	15

1	INTRODUCTION
2	MODES OF OPERATION AND PIN DESCRIPTIONS
3	MEMORY AND REGISTERS
4	INPUT/OUTPUT PORTS
5	MOTOROLA CAN MODULE (MCAN)
6	PROGRAMMABLE TIMER
7	SERIAL COMMUNICATIONS INTERFACE
8	PULSE LENGTH D/A CONVERTERS
9	ANALOG TO DIGITAL CONVERTER
10	RESETS AND INTERRUPTS
11	CPU CORE AND INSTRUCTION SET
12	ELECTRICAL SPECIFICATIONS
13	MECHANICAL DATA
14	ORDERING INFORMATION
15	APPENDICES

How to reach us:

USA/EUROPE/Locations Not Listed: Motorola Literature Distribution; P.O. Box 5405; Denver, Colorado 80217. 1-800-441-2447 or 1-303-675-2140

Mfax™: RMFAX0@email.sps.mot.com, <http://sps.motorola.com/mfax/> – TOUCHTONE 1-602-244-6609
Motorola Fax Back System

INTERNET: <http://motorola.com/sps/>

JAPAN: Nippon Motorola Ltd.; Tatsumi-SPD-JLDC, 6F Seibu-Butsuryu-Center, 3-14-2 Tatsumi Koto-Ku, Tokyo 135, Japan. 81-3-3521-8315

ASIA/PACIFIC: Motorola Semiconductors H.K. Ltd.; 8B Tai Ping Industrial Park, 51 Ting Kok Road, Tai Po, N.T., Hong Kong. 852-26629298

Customer Focus Center: 1-800-521-6274

Mfax is a trademark of Motorola, Inc.



MOTOROLA



LittleDiode supplies new, hard to find or obsolete electronic components and semiconductors all over the world.

With over two million different components listed you are sure to find the part you need.

Feel free to visit us today at our online store:

LittleDiode.com

Looking forward to providing you with the best possible service.