

MM54HC123A/MM74HC123A Dual Retriggerable Monostable Multivibrator

General Description

The MM54/74HC123A high speed monostable multivibrators (one shots) utilize advanced silicon-gate CMOS technology. They feature speeds comparable to low power Schottky TTL circuitry while retaining the low power and high noise immunity characteristic of CMOS circuits.

Each multivibrator features both a negative, A, and a positive, B, transition triggered input, either of which can be used as an inhibit input. Also included is a clear input that when taken low resets the one shot. The 'HC123 can be triggered on the positive transition of the clear while A is held low and B is held high.

The 'HC123A is retriggerable. That is it may be triggered repeatedly while their outputs are generating a pulse and the pulse will be extended.

Pulse width stability over a wide range of temperature and supply is achieved using linear CMOS techniques. The out-

put pulse equation is simply: $PW = (R_{EXT}) (C_{EXT})$; where PW is in seconds, R is in ohms, and C is in farads. All inputs are protected from damage due to static discharge by diodes to V_{CC} and ground.

Features

- Typical propagation delay: 25 ns
- Wide power supply range: 2V–6V
- Low quiescent current: 80 μ A maximum (74HC Series)
- Low input current: 1 μ A maximum
- Fanout of 10 LS-TTL loads
- Simple pulse width formula $T = RC$
- Wide pulse range: 400 ns to ∞ (typ)
- Part to part variation: $\pm 5\%$ (typ)
- Schmitt Trigger A & B inputs enable infinite signal input rise and fall times.

Connection Diagram

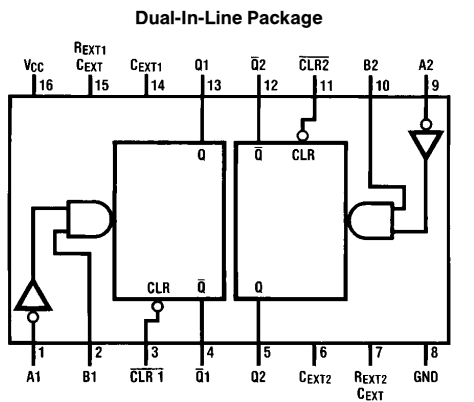

Timing Component

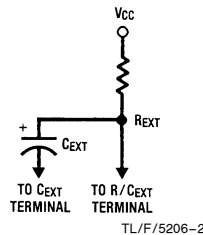

Note: Pin 6 and Pin 14 must be hard-wired to GND.

TL/F/5206-2

Top View

Order Number MM54HC123A or MM74HC123A

Truth Table

Inputs			Outputs	
\overline{Clear}	A	B	Q	\overline{Q}
L	X	X	L	H
X	H	X	L	H
X	X	L	L	H
H	L	\uparrow	\square	\square
H	\downarrow	H	\square	\square
\uparrow	L	H	\square	\square

- H = High Level
- L = Low Level
- \uparrow = Transition from Low to High
- \downarrow = Transition from High to Low
- \square = One High Level Pulse
- \square = One Low Level Pulse
- X = Irrelevant

Absolute Maximum Ratings (Notes 1 & 2)

If Military/Aerospace specified devices are required, please contact the National Semiconductor Sales Office/Distributors for availability and specifications.

Supply Voltage (V_{CC})	-0.5V to +7.0V
DC Input Voltage (V_{IN})	-1.5V to $V_{CC} + 1.5V$
DC Output Voltage (V_{OUT})	-0.5V to $V_{CC} + 0.5V$
Clamp Diode Current (I_{IK}, I_{OK})	± 20 mA
DC Output Current, per pin (I_{OUT})	± 25 mA
DC V_{CC} or GND Current, per pin (I_{CC})	± 50 mA
Storage Temperature Range (T_{STG})	-65°C to +150°C
Power Dissipation (P_D) (Note 3)	600 mW
S.O. Package only	500 mW
Lead Temperature (T_L) (Soldering 10 seconds)	260°C

Operating Conditions

	Min	Max	Units
Supply Voltage (V_{CC})	2	6	V
DC Input or Output Voltage (V_{IN}, V_{OUT})	0	V_{CC}	V
Operating Temp. Range (T_A)			
MM74HC	-40	+85	°C
MM54HC	-55	+125	°C
Input Rise or Fall Times (Clear Input) (t_r, t_f)			
$V_{CC} = 2.0V$		1000	ns
$V_{CC} = 4.5V$		500	ns
$V_{CC} = 6.0V$		400	ns

DC Electrical Characteristics (Note 4)

Symbol	Parameter	Conditions	V_{CC}	$T_A = 25^\circ C$			Units	
				Typ	74HC $T_A = -40$ to $85^\circ C$	54HC $T_A = -55$ to $125^\circ C$		
V_{IH}	Minimum High Level Input Voltage		2.0V	1.5	1.5	1.5	V	
			4.5V	3.15	3.15	3.15	V	
			6.0V	4.2	4.2	4.2	V	
V_{IL}	Maximum Low Level Input Voltage		2.0V	0.3	0.3	0.3	V	
			4.5V	0.9	0.9	0.9	V	
			6.0V	1.2	1.2	1.2	V	
V_{OH}	Minimum High Level Output Voltage	$V_{IN} = V_{IH}$ or V_{IL} $ I_{OUT} \leq 20 \mu A$	2.0V	2.0	1.9	1.9	V	
			4.5V	4.5	4.4	4.4	V	
			6.0V	6.0	5.9	5.9	V	
		$V_{IN} = V_{IH}$ or V_{IL} $ I_{OUT} \leq 4.0$ mA $ I_{OUT} \leq 5.2$ mA	4.5V	4.2	3.98	3.84	V	
			6.0V	5.7	5.48	5.34	V	
			6.0V	5.7	5.48	5.34	V	
V_{OL}	Maximum Low Level Output Voltage	$V_{IN} = V_{IH}$ or V_{IL} $ I_{OUT} \leq 20 \mu A$	2.0V	0	0.1	0.1	V	
			4.5V	0	0.1	0.1	V	
			6.0V	0	0.1	0.1	V	
		$V_{IN} = V_{IH}$ or V_{IL} $ I_{OUT} \leq 4$ mA $ I_{OUT} \leq 5.2$ mA	4.5V	0.2	0.26	0.33	V	
			6.0V	0.2	0.26	0.33	V	
			6.0V	0.2	0.26	0.33	V	
I_{IN}	Maximum Input Current (Pins 7, 15)	$V_{IN} = V_{CC}$ or GND	6.0V		± 0.5	± 5.0	μA	
I_{IN}	Maximum Input Current (all other pins)	$V_{IN} = V_{CC}$ or GND	6.0V		± 0.1	± 1.0	μA	
I_{CC}	Maximum Quiescent Supply Current (standby)	$V_{IN} = V_{CC}$ or GND $I_{OUT} = 0 \mu A$	6.0V		8.0	80	160	μA
I_{CC}	Maximum Active Supply Current (per monostable)	$V_{IN} = V_{CC}$ or GND $R/C_{EXT} = 0.5V_{CC}$	2.0V	36	80	110	130	μA
			4.5V	0.33	1.0	1.3	1.6	mA
			6.0V	0.7	2.0	2.6	3.2	mA

Note 1: Maximum Ratings are those values beyond which damage to the device may occur.

Note 2: Unless otherwise specified all voltages are referenced to ground.

Note 3: Power Dissipation Temperature Derating:

Plastic "N" Package: -12mW/°C from 65°C to 85°C

Ceramic "J" Package: -12mW/°C from 100°C to 125°C.

Note 4: For a power supply of 5V $\pm 10\%$ the worst-case output voltages (V_{OH}, V_{OL}) occur for HC at 4.5V. Thus the 4.5V values should be used when designing with this supply. Worst-case V_{IH} and V_{IL} occur at $V_{CC} = 5.5V$ and 4.5V respectively. (The V_{IH} value at 5.5V is 3.85V.) The worst-case leakage current (I_{IN}, I_{CC} , and I_{OZ}) occur for CMOS at the higher voltage and so the 6.0V values should be used.

AC Electrical Characteristics $V_{CC} = 5V, T_A = 25^\circ C, C_L = 15 \text{ pF}, t_r = t_f = 6 \text{ ns}$

Symbol	Parameter	Conditions	Typ	Limit	Units
t_{PLH}	Maximum Trigger Propagation Delay A, B or Clear to Q		22	33	ns
t_{PHL}	Maximum Trigger Propagation Delay A, B or Clear to \bar{Q}		25	42	ns
t_{PHL}	Maximum Propagation Delay, Clear to Q		20	27	ns
t_{PLH}	Maximum Propagation Delay, Clear to \bar{Q}		22	33	ns
t_W	Minimum Pulse Width, A, B or Clear		14	26	ns
t_{REM}	Minimum Clear Removal Time			0	ns
$t_{WQ(MIN)}$	Minimum Output Pulse Width	$C_{EXT} = 28 \text{ pF}$ $R_{EXT} = 2 \text{ k}\Omega$	400		ns
t_{WQ}	Output Pulse Width	$C_{EXT} = 1000 \text{ pF}$ $R_{EXT} = 10 \text{ k}\Omega$	10		μs

AC Electrical Characteristics $C_L = 50 \text{ pF}, t_r = t_f = 6 \text{ ns}$ (unless otherwise specified)

Symbol	Parameter	Conditions	V_{CC}	$T_A = 25^\circ C$		74HC		54HC		Units
						$T_A = -40 \text{ to } 85^\circ C$		$T_A = -55 \text{ to } 125^\circ C$		
				Typ	Guaranteed Limits					
t_{PLH}	Maximum Trigger Propagation Delay, A, B or Clear to Q		2.0V	77	169	194		210		ns
			4.5V	26	42	51		57		ns
			6.0V	21	32	39		44		ns
t_{PHL}	Maximum Trigger Propagation Delay, A, B or Clear to \bar{Q}		2.0V	88	197	229		250		ns
			4.5V	29	48	60		67		ns
			6.0V	24	38	46		51		ns
t_{PHL}	Maximum Propagation Delay Clear to Q		2.0V	54	114	132		143		ns
			4.5V	23	34	41		45		ns
			6.0V	19	28	33		36		ns
t_{PLH}	Maximum Propagation Delay Clear to \bar{Q}		2.0V	56	116	135		147		ns
			4.5V	25	36	42		46		ns
			6.0V	20	29	34		37		ns
t_W	Minimum Pulse Width A, B, Clear		2.0V	57	123	144		157		ns
			4.5V	17	30	37		42		ns
			6.0V	12	21	27		30		ns
t_{REM}	Minimum Clear Removal Time		2.0V		0	0		0		ns
			4.5V		0	0		0		ns
			6.0V		0	0		0		ns
t_{TLH}, t_{THL}	Maximum Output Rise and Fall Time		2.0V	30	75	95		110		ns
			4.5V	8	15	19		22		ns
			6.0V	7	13	16		19		ns
$t_{WQ(MIN)}$	Minimum Output Pulse Width	$C_{EXT} = 28 \text{ pF}$ $R_{EXT} = 2 \text{ k}\Omega$ $R_{EXT} = 6 \text{ k}\Omega (V_{CC} = 2V)$	2.0V	1.5						μs
			4.5V	450						ns
			6.0V	380						ns
t_{WQ}	Output Pulse Width	$C_{EXT} = 0.1 \text{ }\mu\text{F}$ $R_{EXT} = 10 \text{ k}\Omega$	Min	5.0V	1	0.9	0.86		0.85	ms
			Max	5.0V	1	1.1	1.14		1.15	ms
C_{IN}	Maximum Input Capacitance (Pins 7 & 15)			12	20	20		20		pF
C_{IN}	Maximum Input Capacitance (other inputs)			6	10	10		10		pF
C_{PD}	Power Dissipation Capacitance	(Note 5)		70						pF

Note 5: C_{PD} determines the no load dynamic power consumption, $P_D = C_{PD} V_{CC}^2 f + I_{CC} V_{CC}$, and the no load dynamic current consumption, $I_S = C_{PD} V_{CC} f + I_{CC}$.

Logic Diagram

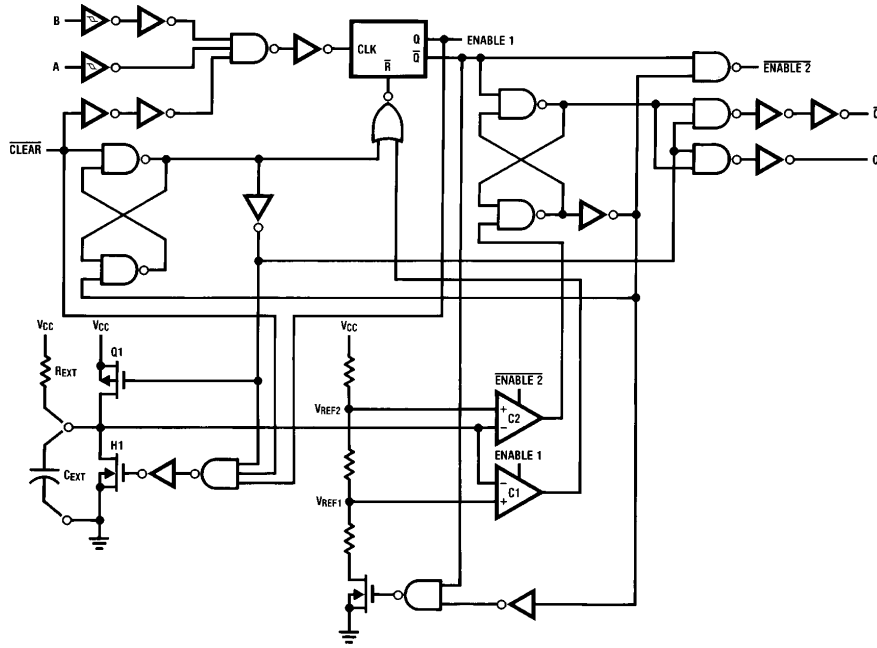

TL/F/5206-5

Theory of Operation

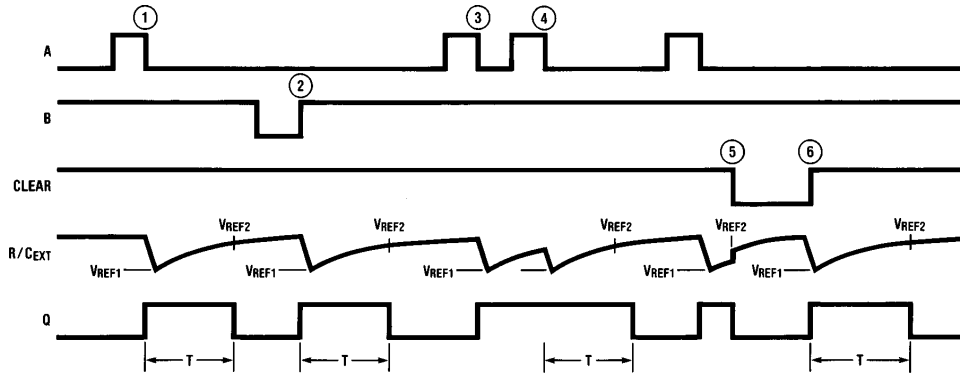

TL/F/5206-6

- ⊙ POSITIVE EDGE TRIGGER
- ⊙ POSITIVE EDGE RE-TRIGGER (PULSE LENGTHENING)
- ⊙ NEGATIVE EDGE TRIGGER
- ⊙ RESET PULSE SHORTENING
- ⊙ POSITIVE EDGE TRIGGER
- ⊙ CLEAR TRIGGER

FIGURE 1

TRIGGER OPERATION

As shown in *Figure 1* and the logic diagram before an input trigger occurs, the one shot is in the quiescent state with the Q output low, and the timing capacitor C_{EXT} completely charged to V_{CC} . When the trigger input A goes from V_{CC} to GND (while inputs B and clear are held to V_{CC}) a valid trigger is recognized, which turns on comparator C1 and N-

channel transistor N1 ⊙. At the same time the output latch is set. With transistor N1 on, the capacitor C_{EXT} rapidly discharges toward GND until V_{REF1} is reached. At this point the output of comparator C1 changes state and transistor N1 turns off. Comparator C1 then turns off while at the same time comparator C2 turns on. With transistor N1 off, the capacitor C_{EXT} begins to charge through the timing re-

sistor, R_{EXT} , toward V_{CC} . When the voltage across C_{EXT} equals V_{REF2} , comparator C2 changes state causing the output latch to reset (Q goes low) while at the same time disabling comparator C2. This ends the timing cycle with the monostable in the quiescent state, waiting for the next trigger.

A valid trigger is also recognized when trigger input B goes from GND to V_{CC} (while input A is at GND and input clear is at V_{CC}). The 'HC123A can also be triggered when clear goes from GND to V_{CC} (while A is at GND and B is at V_{CC}).

It should be noted that in the quiescent state C_{EXT} is fully charged to V_{CC} causing the current through resistor R_{EXT} to be zero. Both comparators are "off" with the total device current due only to reverse junction leakages. An added feature of the 'HC123A is that the output latch is set via the input trigger without regard to the capacitor voltage. Thus, propagation delay from trigger to Q is independent of the value of C_{EXT} , R_{EXT} , or the duty cycle of the input waveform.

RETRIGGER OPERATION

The 'HC123A is retriggered if a valid trigger occurs followed by another trigger before the Q output has returned to the quiescent (zero) state. Any retrigger, after the timing node voltage at the R/ C_{EXT} pin has begun to rise from V_{REF1} , but has not yet reached V_{REF2} , will cause an increase in output pulse width T. When a valid retrigger is initiated, the voltage at the R/ C_{EXT} pin will again drop to V_{REF1} before progressing along the RC charging curve

toward V_{CC} . The Q output will remain high until time T, after the last valid retrigger.

Because the trigger-control circuit flip-flop resets shortly after C_X has discharged to the reference voltage of the lower reference circuit, the minimum retrigger time, t_{rr} is a function of internal propagation delays and the discharge time of C_X :

$$t_{rr} \approx 20 + \frac{187}{V_{CC} - 0.7} + \frac{565 + (0.256 V_{CC}) C_X}{[V_{CC} - 0.7]^2}$$

Another removal/retrigger time occurs when a short clear pulse is used. Upon receipt of a clear, the one shot must charge the capacitor up to the upper trip point before the one shot is ready to receive the next trigger. This time is dependent on the capacitor used and is approximately:

$$t_{rr} = 196 + \frac{640}{V_{CC} - 0.7} + \frac{522 + (0.3 V_{CC}) C_X}{(V_{CC} - 0.7)^2} \text{ ns}$$

RESET OPERATION

These one shots may be reset during the generation of the output pulse. In the reset mode of operation, an input pulse on clear sets the reset latch and causes the capacitor to be fast charged to V_{CC} by turning on transistor Q1. When the voltage on the capacitor reaches V_{REF2} , the reset latch will clear and then be ready to accept another pulse. If the clear input is held low, any trigger inputs that occur will be inhibited and the Q and \bar{Q} outputs of the output latch will not change. Since the Q output is reset when an input low level is detected on the Clear input, the output pulse T can be made significantly shorter than the minimum pulse width specification.

Typical Output Pulse Width vs. Timing Components

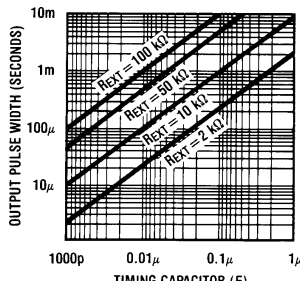

TL/F/5206-7

Typical Distribution of Output Pulse Width, Part to Part

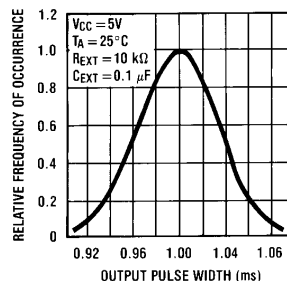

TL/F/5206-8

Typical 1ms Pulse Width Variation vs. Supply

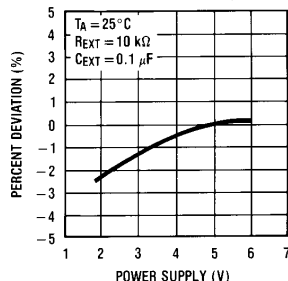

TL/F/5206-9

Minimum REXT vs. Supply Voltage

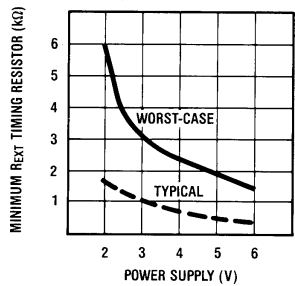

TL/F/5206-10

Typical 1ms Pulse Width Variation vs. Temperature

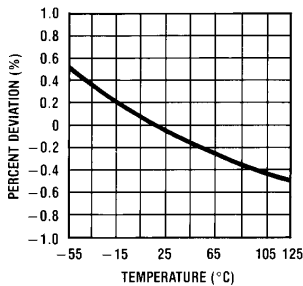

TL/F/5206-11

Note: R and C are not subjected to temperature. The C is polypropylene.

Physical Dimensions inches (millimeters)

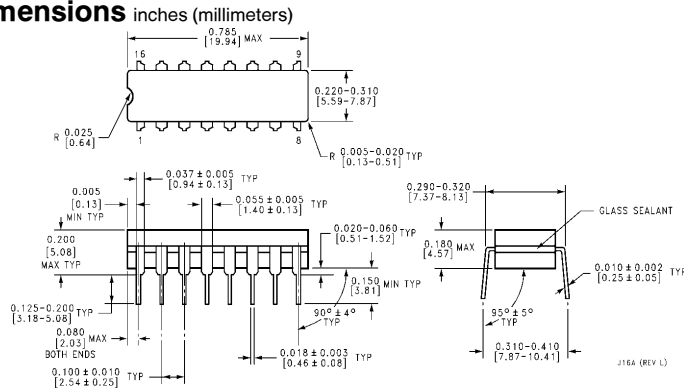

Dual-In-Line Package (J)
Order Number MM54HC123AJ or MM74HC123AJ
NS Package Number J16A

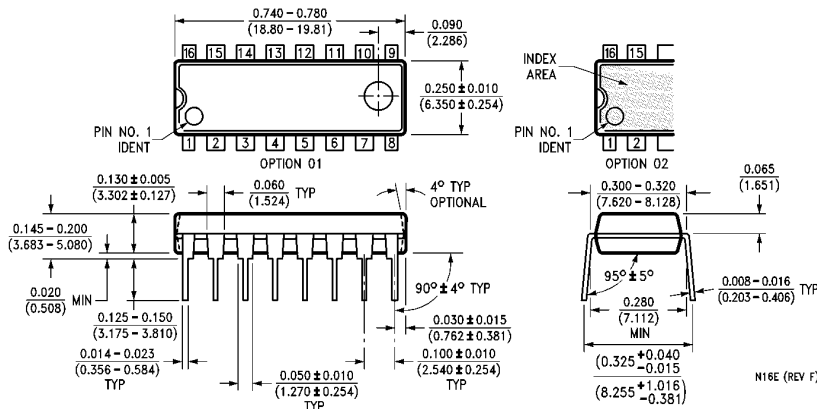

Dual-In-Line Package (N)
Order Number MM74HC123AN
NS Package Number N16E

LIFE SUPPORT POLICY

NATIONAL'S PRODUCTS ARE NOT AUTHORIZED FOR USE AS CRITICAL COMPONENTS IN LIFE SUPPORT DEVICES OR SYSTEMS WITHOUT THE EXPRESS WRITTEN APPROVAL OF THE PRESIDENT OF NATIONAL SEMICONDUCTOR CORPORATION. As used herein:

1. Life support devices or systems are devices or systems which, (a) are intended for surgical implant into the body, or (b) support or sustain life, and whose failure to perform, when properly used in accordance with instructions for use provided in the labeling, can be reasonably expected to result in a significant injury to the user.
2. A critical component is any component of a life support device or system whose failure to perform can be reasonably expected to cause the failure of the life support device or system, or to affect its safety or effectiveness.



National Semiconductor Corporation
 1111 West Bardin Road
 Arlington, TX 76017
 Tel: (800) 272-9959
 Fax: (800) 737-7018

National Semiconductor Europe
 Fax: (+49) 0-180-530 85 86
 Email: onjwge@tevm2.nsc.com
 Deutsch Tel: (+49) 0-180-530 85 85
 English Tel: (+49) 0-180-532 78 32
 Français Tel: (+49) 0-180-532 93 58
 Italiano Tel: (+49) 0-180-534 16 80

National Semiconductor Hong Kong Ltd.
 19th Floor, Straight Block,
 Ocean Centre, 5 Canton Rd.
 Tsimshatsui, Kowloon
 Hong Kong
 Tel: (852) 2737-1600
 Fax: (852) 2736-9960

National Semiconductor Japan Ltd.
 Tel: 81-043-299-2309
 Fax: 81-043-299-2408

National does not assume any responsibility for use of any circuitry described, no circuit patent licenses are implied and National reserves the right at any time without notice to change said circuitry and specifications.

This datasheet has been downloaded from:

www.DatasheetCatalog.com

Datasheets for electronic components.

National Semiconductor was acquired by Texas Instruments.

http://www.ti.com/corp/docs/investor_relations/pr_09_23_2011_national_semiconductor.html

This file is the datasheet for the following electronic components:

HC123 - <http://www.ti.com/product/hc123?HQS=TI-null-null-dscatalog-df-pf-null-wwe>

MM54HC123AJ - <http://www.ti.com/product/mm54hc123aj?HQS=TI-null-null-dscatalog-df-pf-null-wwe>

MM74HC123AJ - <http://www.ti.com/product/mm74hc123aj?HQS=TI-null-null-dscatalog-df-pf-null-wwe>



LittleDiode supplies new, hard to find or obsolete electronic components and semiconductors all over the world.

With over two million different components listed you are sure to find the part you need.

Feel free to visit us today at our online store:

LittleDiode.com

Looking forward to providing you with the best possible service.