

**ITU Low Cost, PABX SLIC With 40mA Loop Feed**

The Intersil SLIC incorporates many of the BORSHT functions on a single IC chip. This includes DC battery feed, a ring relay driver, supervisory and hybrid functions. This device is designed to maintain transmission performance in the presence of externally induced longitudinal currents. Using the unique Intersil dielectric isolation process, the SLIC can operate directly with a wide range of station battery voltages.

The SLIC also provides selective denial of power. If the PBX system becomes overloaded during an emergency, the SLIC will provide system protection by denying power to selected subscriber loops.

The Intersil SLIC is ideally suited for the design of new digital PBX systems by eliminating bulky hybrid transformers.

**Ordering Information**

PART NUMBER	TEMP. RANGE (°C)	PACKAGE	PKG. NO.
HC4P5504B1-5	0 to 75	28 Ld PLCC	N28.45

**Pinout**

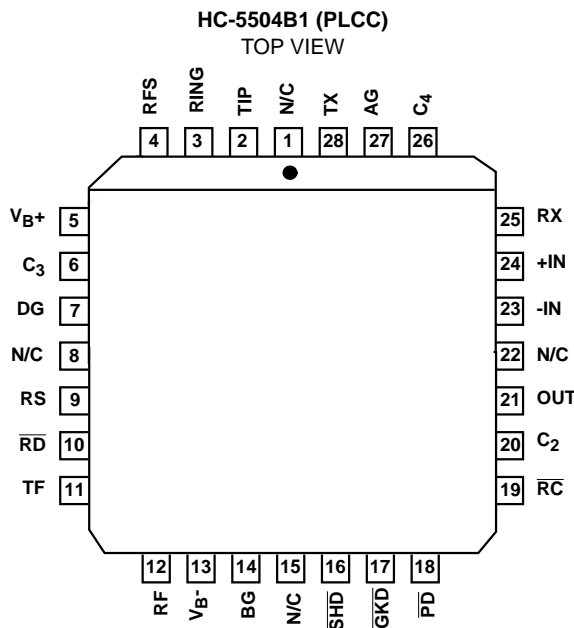

**Features**

- Low Cost Version of the HC-5504B
- Capable of 5V or 12V (V<sub>B+</sub>) Operation
- Monolithic Integrated Device
- DI High Voltage Process
- Compatible With Worldwide PBX Performance Requirements
- Controlled Supply of Battery Feed Current for Short Loops (41mA)
- Internal Ring Relay Driver
- Allows Interfacing With Negative Superimposed Ringing Systems
- Low Power Consumption During Standby
- Switch Hook Ground Key and Ring Trip Detection Functions
- Selective Denial of Power to Subscriber Loops

**Applications**

- Solid State Line Interface Circuit for Analog and Digital PBX Systems
- Direct Inward Dial (DID) Trunks
- Voice Messaging PBXs
- Related Literature
  - AN549, The HC-5502S/4X Telephone Subscriber Line Interface Circuits (SLIC)
  - AN571, Using Ring Sync with HC-5502A and HC-5504 SLICs

# HC-5504B1

## Absolute Maximum Ratings (Note 1)

Maximum Continuous Supply Voltages	
(V <sub>B-</sub> )	-60 to 0.5V
(V <sub>B+</sub> )	-0.5 to 15V
(V <sub>B+</sub> - V <sub>B-</sub> )	.75V
Relay Drive Voltage (V <sub>RD</sub> )	-0.5 to 15V

## Operating Conditions

Operating Temperature Range	
HC-5504B1-5	0°C to 75°C
Relay Driver Voltage (V <sub>RD</sub> )	5V to 12V
Positive Supply Voltage (V <sub>B+</sub> )	4.75V to 5.25V or 10.8V to 13.2V
Negative Supply Voltage (V <sub>B-</sub> )	-42V to -58V
High Level Logic Input Voltage	2.4V
Low Level Logic Input Voltage	0.6V
Loop Resistance (R <sub>L</sub> )	200Ω to 1200Ω

**CAUTION:** Stresses above those listed in "Absolute Maximum Ratings" may cause permanent damage to the device. This is a stress only rating and operation of the device at these or any other conditions above those indicated in the operational sections of this specification is not implied.

### NOTES:

1. Absolute maximum ratings are limiting values, applied individually, beyond which the serviceability of the circuit may be impaired. Functional operability under any of these conditions is not necessarily implied.
2. θ<sub>JA</sub> is measured with the component mounted on an evaluation PC board in free air.

## Thermal Information

Thermal Resistance (Typical, Note 2)	θ <sub>JA</sub> (°C/W)
28 Lead PLCC	65
Maximum Junction Temperature Plastic	150°C
Maximum Storage Temperature Range	-65°C to 150°C
Maximum Lead Temperature (Soldering 10s)	300°C
(PLCC - Lead Tips Only)	

## Die Characteristics

Transistor Count	185
Diode Count	36
Die Dimensions	137 x 102
Substrate Potential	Connected
Process	Bipolar-DI

**Electrical Specifications** Unless Otherwise Specified, V<sub>B-</sub> = -48V, V<sub>B+</sub> = 12V and 5V, AG = BG = DG = 0V, Typical Parameters T<sub>A</sub> = 25°C. Min-Max Parameters are Over Operating Temperature Range

PARAMETER	CONDITIONS	MIN	TYP	MAX	UNITS
On Hook Power Dissipation	I <sub>LONG</sub> = 0 (Note 2), V <sub>B+</sub> = 12V	-	170	235	mW
Off Hook Power Dissipation	R <sub>L</sub> = 600Ω, I <sub>LONG</sub> = 0 (Note 3), V <sub>B+</sub> = 12V	-	425	550	mW
Off Hook I <sub>B+</sub>	R <sub>L</sub> = 600Ω, I <sub>LONG</sub> = 0 (Note 3), T <sub>A</sub> = 25°C	-	-	5.3	mA
Off Hook I <sub>B-</sub>	R <sub>L</sub> = 600Ω, I <sub>LONG</sub> = 0 (Note 3)	-	35	41	mA
Off Hook Loop Current	R <sub>L</sub> = 1200Ω, I <sub>LONG</sub> = 0 (Note 3)	-	21	-	mA
Off Hook Loop Current	R <sub>L</sub> = 1200Ω, V <sub>B-</sub> = -42V, I <sub>LONG</sub> = 0 (Note 3) T <sub>A</sub> = 25°C	17.5	-	-	mA
Off Hook Loop Current	R <sub>L</sub> = 200Ω, I <sub>LONG</sub> = 0 (Note 3)	36	41	48	mA
Fault Currents					
TIP to Ground		-	14	-	mA
RING to Ground		-	55	-	mA
TIP to RING		-	41	-	mA
TIP and RING to Ground		-	55	-	mA
Ring Relay Drive V <sub>OL</sub>	I <sub>OL</sub> = 62mA	-	0.2	0.5	V
Ring Relay Driver Off Leakage	V <sub>RD</sub> = 12V, R <sub>C</sub> = 1 = HIGH, T <sub>A</sub> = 25°C	-	-	100	μA
Ring Trip Detection Period	R <sub>L</sub> = 600Ω	-	2	3	Ring Cycles
Switch Hook Detection Threshold	SHD = V <sub>OL</sub>	10	-	-	mA
	SHD = V <sub>OH</sub>	-	-	5	mA

## HC-5504B1

**Electrical Specifications** Unless Otherwise Specified,  $V_{B-} = -48V$ ,  $V_{B+} = 12V$  and  $5V$ ,  $AG = BG = DG = 0V$ , Typical Parameters  $T_A = 25^{\circ}C$ . Min-Max Parameters are Over Operating Temperature Range **(Continued)**

PARAMETER	CONDITIONS	MIN	TYP	MAX	UNITS	
Ground Key Detection Threshold	$\overline{GKD} = V_{OL}$	20	-	-	mA	
	$\overline{GKD} = V_{OH}$	-	-	10	mA	
Loop Current During Power Denial	$R_L = 200\Omega$	-	$\pm 2$	-	mA	
Dial Pulse Distortion		0	-	5	ms	
Receive Input Impedance	(Note 4)	-	110	-	k $\Omega$	
Transmit Output Impedance	(Note 4)	-	10	20	$\Omega$	
2-Wire Return Loss	(Referenced to $600\Omega + 2.16\mu F$ ), (Note 4)	-	15.5	-	dB	
$SR_L$ LO		-	24	-	dB	
$ER_L$		-	31	-	dB	
SR <sub>L</sub> HI		-		-	dB	
Longitudinal Balance	$1V_{RMS}$ 200Hz - 3400Hz, (Note 4) IEEE Method $0^{\circ}C \leq T_A \leq 75^{\circ}C$	53	58	-	dB	
2-Wire Off Hook		53	58	-	dB	
2-Wire On Hook		50	58	-	dB	
4-Wire Off Hook						
Low Frequency Longitudinal Balance	R.E.A. Method, (Note 4), $R_L = 600\Omega$ $0^{\circ}C \leq T_A \leq 75^{\circ}C$	-	-	23	dBmC	
		-	-	-67	dBm0p	
Insertion Loss	At 1kHz, 0dBm Input Level, Referenced 600 $\Omega$	-	$\pm 0.05$	$\pm 0.2$	dB	
2-Wire to 4-Wire, 4-Wire to 2-Wire						
Frequency Response	200 - 3400Hz Referenced to Absolute Loss at 1kHz and 0dBm Signal Level (Note 4)	-	$\pm 0.02$	$\pm 0.05$	dB	
Idle Channel Noise	(Note 4)	-	1	5	dBmC	
2-Wire to 4-Wire, 4-Wire to 2-Wire		-	-89	-85	dBm0p	
Absolute Delay	(Note 4)	-	-	2	ms	
2-Wire to 4-Wire, 4-Wire to 2-Wire						
Trans Hybrid Loss	Balance Network Set Up for 600 $\Omega$ Termination at 1kHz	30	40	-	dB	
Overload Level	$V_{B+} = +5V$	1.5	-	-	$V_{PEAK}$	
2-Wire to 4-Wire, 4-Wire to 2-Wire	$V_{B+} = 12V$	1.75	-	-	$V_{PEAK}$	
Level Linearity	At 1kHz, (Note 4) Referenced to 0dBm Level +3 to -40dBm	-	-	$\pm 0.05$	dB	
2-Wire to 4-Wire, 4-Wire to 2-Wire		-40 to -50dBm	-	-	$\pm 0.1$	dB
		-50 to -55dBm	-	-	$\pm 0.3$	dB

## HC-5504B1

**Electrical Specifications** Unless Otherwise Specified,  $V_{B-} = -48V$ ,  $V_{B+} = 12V$  and  $5V$ ,  $AG = BG = DG = 0V$ , Typical Parameters  $T_A = 25^{\circ}C$ . Min-Max Parameters are Over Operating Temperature Range **(Continued)**

PARAMETER	CONDITIONS	MIN	TYP	MAX	UNITS
Power Supply Rejection Ratio	(Note 4)				
$V_{B+}$ to 2-Wire	30 - 60Hz, $R_L = 600\Omega$	15	-	-	dB
$V_{B+}$ to Transmit		15	-	-	dB
$V_{B-}$ to 2-Wire		15	-	-	dB
$V_{B-}$ to Transmit		15	-	-	dB
$V_{B+}$ to 2-Wire	200 - 16kHz, $R_L = 600\Omega$	30	-	-	dB
$V_{B+}$ to Transmit		30	-	-	dB
$V_{B-}$ to 2-Wire		30	-	-	dB
$V_{B-}$ to Transmit		30	-	-	dB
Logic Input Current ( $R_S$ , $\overline{RC}$ , $\overline{PD}$ )	$0V \leq V_{IN} \leq 5V$	-	-	$\pm 100$	$\mu A$
Logic Inputs					
Logic '0' $V_{IL}$		-	-	0.8	V
Logic '1' $V_{IH}$		2.0	-	5.5	V
Logic Outputs					
Logic '0' $V_{OL}$	$I_{LOAD} 800\mu A$ , $V_{B+} = 12V$ , $5V$	-	0.1	0.5	V
Logic '1' $V_{OH}$	$I_{LOAD} 80\mu A$ , $V_{B+} = 12V$	2.7	5.0	5.5	V
	$I_{LOAD} 40\mu A$ , $V_{B+} = 5V$	2.7	-	5.0	V

### Uncommitted Op Amp Specifications

PARAMETER	CONDITIONS	MIN	TYP	MAX	UNITS
Input Offset Voltage		-	$\pm 5$	-	mV
Input Offset Current		-	$\pm 10$	-	nA
Input Bias Current		-	20	-	nA
Differential Input Resistance	(Note 4)	-	1	-	$M\Omega$
Output Voltage Swing	$R_L = 10K$ , $V_{B+} = 12V$	-	$\pm 6.2$	$\pm 6.6$	$V_{PEAK}$
	$R_L = 10K$ , $V_{B+} = 5V$	-	$\pm 3$	-	$V_{PEAK}$
Output Resistance	$A_{VCL} = 1$ (Note 4)	-	10	-	$\Omega$
Small Signal GBW	(Note 4)	-	1	-	MHz

NOTES:

3.  $I_{LONG}$  = Longitudinal Current
4. These parameters are controlled by design or process parameters and are not directly tested. These parameters are characterized upon initial design release, upon design changes which would affect these characteristics, and at intervals to assure product quality and specification compliance.

**Pin Descriptions**

28 PIN PLCC	SYMBOL	DESCRIPTION
2	TIP	An analog input connected to the TIP (more positive) side of the subscriber loop through a 150Ω feed resistor and a ring relay contact. Functions with the Ring terminal to receive voice signals from the telephone and for loop monitoring purposes.
3	RING	An analog input connected to the RING (more negative) side of the subscriber loop through a 150Ω feed resistor and a ring relay contact. Functions with the Tip terminal to receive voice signals from the telephone and for loop monitoring purposes.
4	RFS	Senses ring side of loop for ground key and ring trip detection. During ringing, the ring signal is inserted into the line at this node and RF is isolated from RFS via a relay.
5	V <sub>B+</sub>	Positive Voltage Source - Most positive supply. V <sub>B+</sub> is typically 12V or 5V.
6	C <sub>3</sub>	Capacitor #3 - An external capacitor to be connected between this terminal and analog ground. Required for proper operation of the loop current limiting function, and for filtering V <sub>B-</sub> . Typical value is 0.3μF, 30V.
7	DG	Digital Ground - To be connected to zero potential and serves as a reference for all digital inputs and outputs on the SLIC microcircuit.
9	RS	Ring Synchronization Input - A TTL - compatible clock input. The clock should be arranged such that a positive pulse transition occurs on the zero crossing of the ring voltage source, as it appears at the RFS terminal. For Tip side injected systems, the RS pulse should occur on the negative going zero crossing and for Ring injected systems, on the positive going zero crossing. This ensures that the ring relay activates and deactivates when the instantaneous ring voltage is near zero. If synchronization is not required, the pin should be tied to 5V.
10	RD	Relay Driver - A low active open collector logic output. When enabled, the external ring relay is energized.
11	TF	Tip Feed - A low impedance analog output connected to the TIP terminal through a 150Ω feed resistor. Functions with the RF terminal to provide loop current, feed voice signals to the telephone set, and sink longitudinal current.
12	RF	Ring Feed - A low impedance analog output connected to the RING terminal through a 150Ω feed resistor. Functions with the TF terminal to provide loop current, feed voice signals to the telephone set, and sink longitudinal current.
13	V <sub>B-</sub>	Negative Voltage Source - Most negative supply. V <sub>B-</sub> is typically -48V with an operational range of -42V to -58V. Frequently referred to as "battery".
14	BG	Battery Ground - To be connected to zero potential. All loop current and some quiescent current flows into this ground terminal.
16	SHD	Switch Hook Detection - A low active LS TTL-compatible logic output. This output is enabled for loop currents exceeding 10mA and disabled for loop currents less than 5mA.
17	GKD	Ground Key Detection - A low active LS TTL-compatible logic output. This output is enabled if the DC current into the ring lead exceeds the DC current out of the tip lead by more than 20mA, and disabled if this current difference is less than 10mA.
18	PD	Power Denial - A low active TTL - Compatible logic input. When enabled, the switch hook detect (SHD) and ground key detect (GKD) are not necessarily valid, and the relay driver (RD) output is disabled.
19	RC	Ring Command - A low active TTL - Compatible logic input. When enabled, the relay driver (RD) output goes low on the next high level of the ring sync (RS) input, as long as the SLIC is not in the power denial state (PD = 0) or the subscriber is not already off-hook (SHD = 0).
20	C <sub>2</sub>	Capacitor #2 - An external capacitor to be connected between this terminal and digital ground. Prevents false ground key indications from occurring during ring trip detection. Typical value is 0.15μF, 10V. This capacitor is not used if ground key function is not required and (Pin 17) may be left open or connected to digital ground.
21	OUT	The analog output of the spare operational amplifier. The output voltage swing is typically ±5V.
23	-IN	The inverting analog input of the spare operational amplifier.
24	+IN	The non-inverting analog input of the spare operational amplifier.
25	RX	Receive Input, Four Wire Side - A high impedance analog input which is internally biased. Capacitive coupling to this input is required. AC signals appearing at this input differentially drive the Tip feed and Ring feed terminals, which in turn drive tip and ring through 300Ω of feed resistance on each side of the line.

**Pin Descriptions** (Continued)

28 PIN PLCC	SYMBOL	DESCRIPTION
26	C <sub>4</sub>	Capacitor #4 - An external capacitor to be connected between this terminal and analog ground. This capacitor prevents false ground key indication and false ring trip detection from occurring when longitudinal currents are induced onto the subscriber loop from near by power lines and other noise sources. This capacitor is also required for the proper operation of ring trip detection. Typical value is 0.5μF, to 1.0μF, 20V. This capacitor should be nonpolarized.
27	AG	Analog Ground - To be connected to zero potential and serves as a reference for the transmit output (TX) and receive input (RX) terminals.
28	TX	Transmit Output, Four Wire Side - A low impedance analog output which represents the differential voltage across Tip and Ring. Transhybrid balancing must be performed (using the SLIC microcircuit's spare op amp) beyond this output to completely implement two to four wire conversion. This output is unbalanced and referenced to analog ground. Since the DC level of this output varies with loop current, capacitive coupling to the next stage is essential.
1, 8, 15, 22	NC	No internal connection.

NOTE: All grounds (AG, BG, and DG) must be applied before V<sub>B+</sub> or V<sub>B-</sub>. Failure to do so may result in premature failure of the part. If a user wishes to run separate grounds off a line card, the AG must be applied first.

**Functional Diagram**

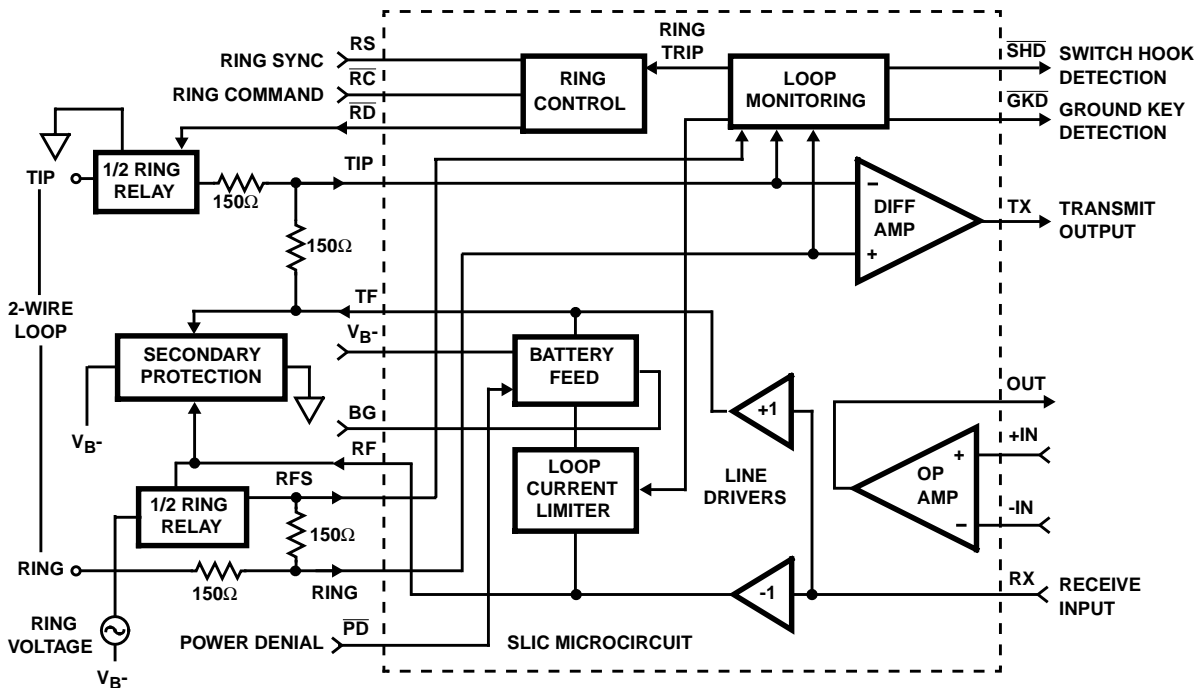

Schematic

SLIC FUNCTIONAL SCHEMATIC  
DIP/SOIC Pin Numbers Shown

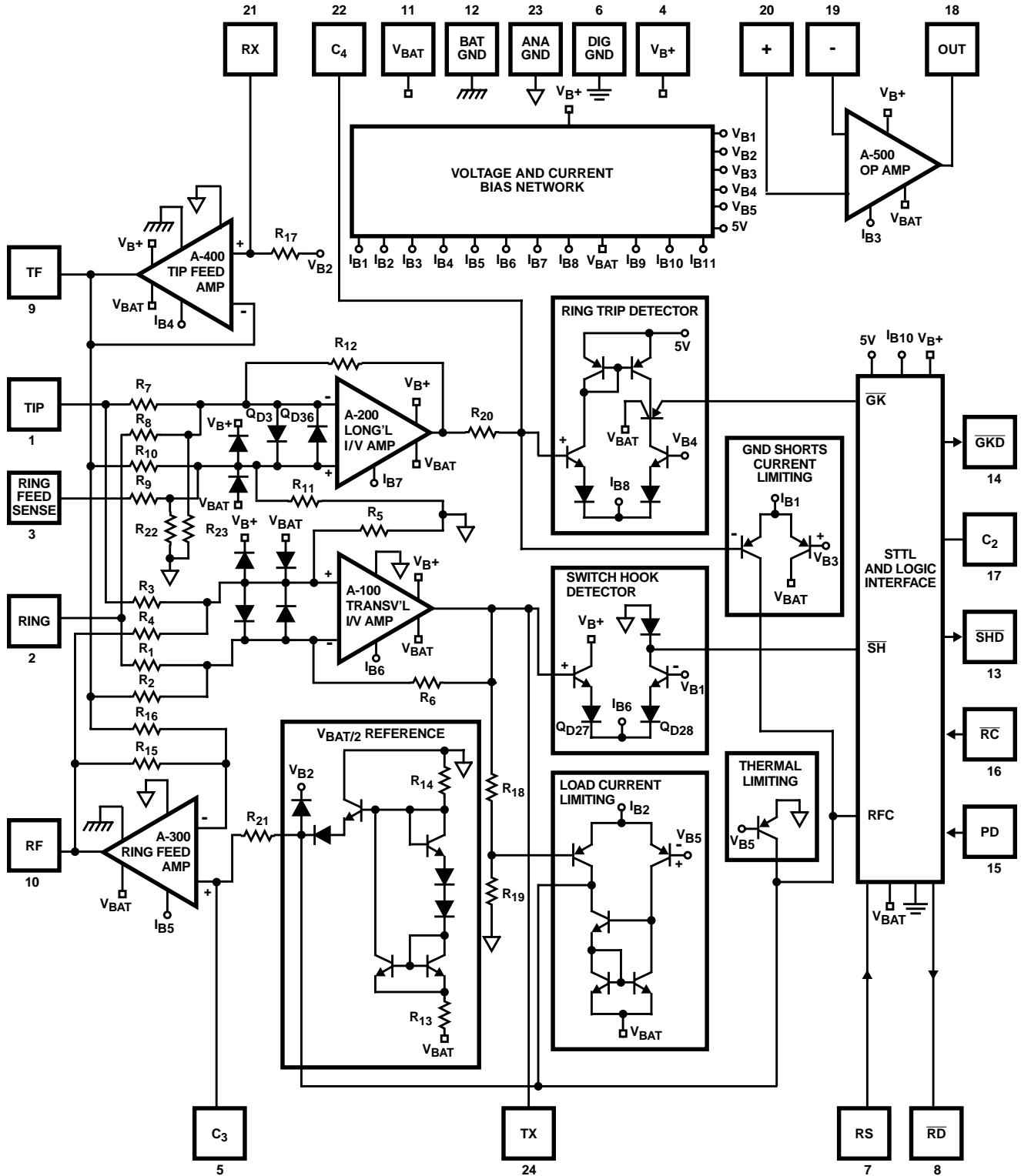

Schematic (Continued)

LOGIC GATE SCHEMATIC

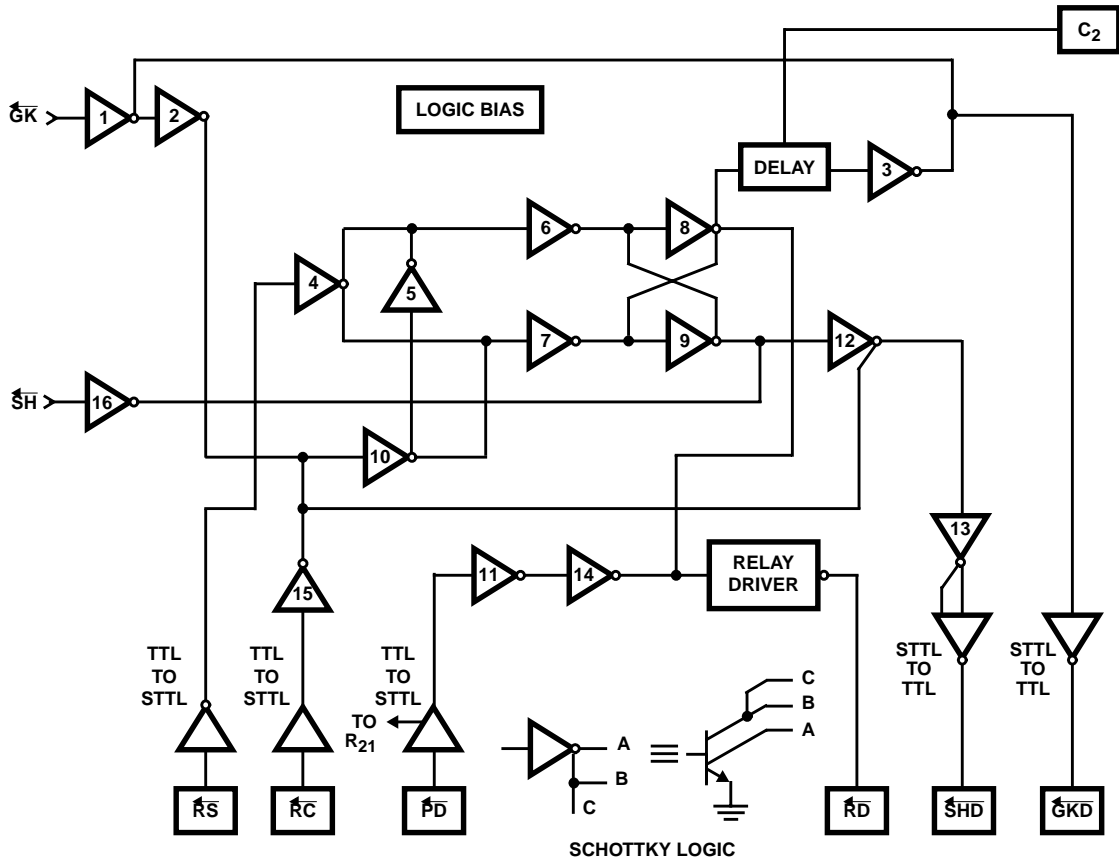

**Overvoltage Protection and Longitudinal Current Protection**

The SLIC device, in conjunction with an external protection bridge, will withstand high voltage lightning surges and power line crosses.

High voltage surge conditions are as specified in Table 1.

The SLIC will withstand longitudinal currents up to a maximum of 30mARMS, 15mARMS per leg, without any performance degradation.

TABLE 1.

PARAMETER	TEST CONDITION	PERFORMANCE (MAX)	UNITS
Longitudinal Surge	10µs Rise/ 1000µs Fall	±1000 (Plastic)	VPEAK
Metallic Surge	10µs Rise/ 1000µs Fall	±1000 (Plastic)	VPEAK
T/GND R/GND	10µs Rise/ 1000µs Fall	±1000 (Plastic)	VPEAK
50/60Hz Current T/GND R/GND	11 Cycles Limited to 10ARMS	700 (Plastic)	VRMS

Applications Diagram

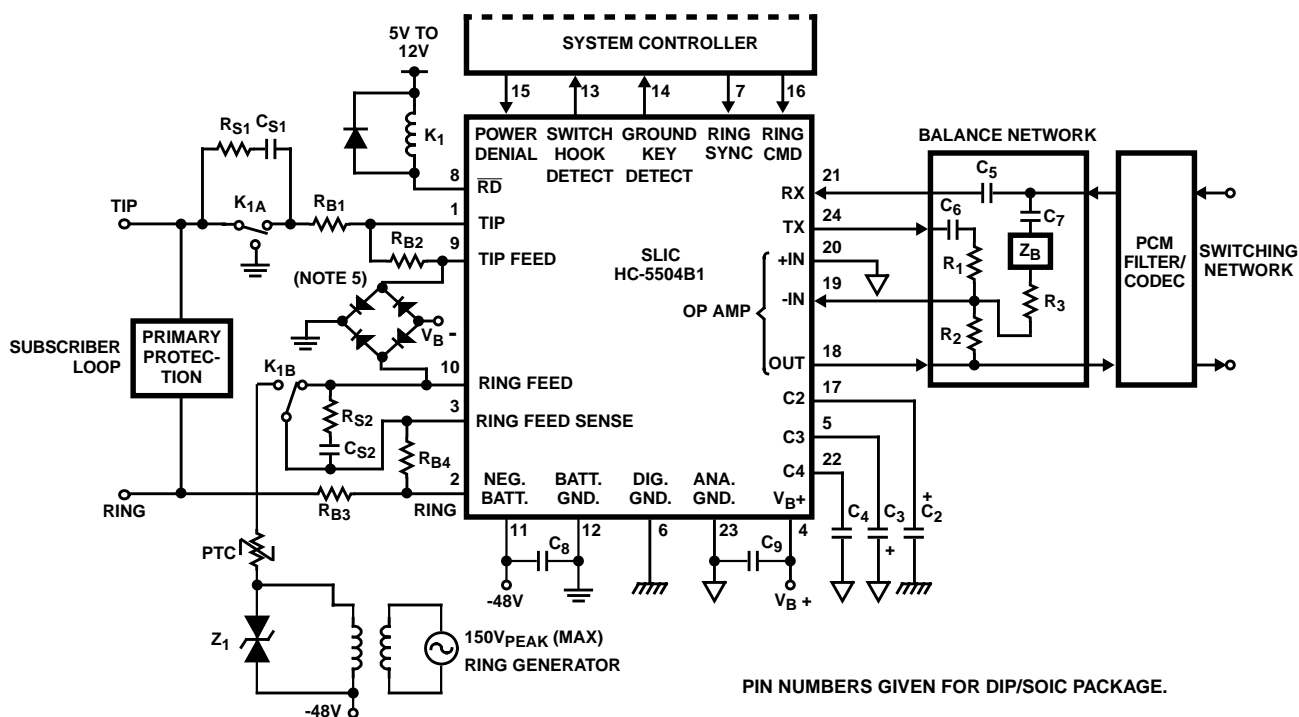

FIGURE 1. TYPICAL LINE CIRCUIT APPLICATION WITH THE MONOLITHIC SLIC

Typical Component Values

- C<sub>2</sub> = 0.15μF, 10V
- C<sub>3</sub> = 0.3μF, 30V
- C<sub>4</sub> = 0.5μF to 1.0μF, 10%, 20V (Should be nonpolarized)
- C<sub>5</sub> = 0.5μF, 20V
- C<sub>6</sub> = C<sub>7</sub> = 0.5μF (10% Match Required) (Note 6)
- C<sub>8</sub> = 0.01μF, 100V
- C<sub>9</sub> = 0.01μF, 20V, ±20%

- R<sub>1</sub> = R<sub>2</sub> = R<sub>3</sub> = 100kΩ (0.1% Match Required, 1% absolute value) Z<sub>B</sub> = 0 for 600Ω Terminations (Note 6).
- R<sub>B1</sub> = R<sub>B2</sub> = R<sub>B3</sub> = R<sub>B4</sub> = 150Ω (0.1% Match Required, 1% absolute value).
- R<sub>S1</sub> = R<sub>S2</sub> = 1kΩ, typically.
- C<sub>S1</sub> = C<sub>S2</sub> = 0.1μF, 200V typically, depending on V<sub>RING</sub> and line length.
- Z<sub>1</sub> = 150V to 200V transient protection.
- PTC used as ring generator ballast.

NOTES:

5. Secondary protection diode bridge recommended is a 2A, 200V type.
6. To obtain the specified transhybrid loss it is necessary for the three legs of the balance network, C<sub>6</sub>-R<sub>1</sub> and R<sub>2</sub> and C<sub>7</sub>-Z<sub>B</sub>-R<sub>3</sub>, to match in impedance to within 0.3%. Thus, if C<sub>6</sub> and C<sub>7</sub> are 1μF each, a 20% match is adequate. It should be noted that the transmit output to C<sub>6</sub> sees a -22V step when the loop is closed. Too large a value for C<sub>6</sub> may produce an excessively long transient at the op amp output to the PCM Filter/CODEC.  
A 0.5μF and 100kΩ gives a time constant of 50ms. The uncommitted op amp output is internally clamped to stay within ±5.5V and also has current limiting protection.
7. All grounds (AG, BG, and DG) must be applied before V<sub>B+</sub> or V<sub>B-</sub>. Failure to do so may result in premature failure of the part. If a user wishes to run separate grounds off a line card, the AG must be applied first.
8. Application shows Ring Injected Ringing, Balanced or Tip injected configuration may be used.

All Intersil semiconductor products are manufactured, assembled and tested under ISO9000 quality systems certification.

Intersil semiconductor products are sold by description only. Intersil Corporation reserves the right to make changes in circuit design and/or specifications at any time without notice. Accordingly, the reader is cautioned to verify that data sheets are current before placing orders. Information furnished by Intersil is believed to be accurate and reliable. However, no responsibility is assumed by Intersil or its subsidiaries for its use; nor for any infringements of patents or other rights of third parties which may result from its use. No license is granted by implication or otherwise under any patent or patent rights of Intersil or its subsidiaries.

For information regarding Intersil Corporation and its products, see web site <http://www.intersil.com>

This datasheet has been downloaded from:

[www.DatasheetCatalog.com](http://www.DatasheetCatalog.com)

Datasheets for electronic components.



LittleDiode supplies new, hard to find or obsolete electronic components and semiconductors all over the world.

With over two million different components listed you are sure to find the part you need.

Feel free to visit us today at our online store:

[LittleDiode.com](http://LittleDiode.com)

Looking forward to providing you with the best possible service.