

4 STAGE PARALLEL IN/PARALLEL OUT SHIFT REGISTER

- 4 STAGE CLOCKED SHIFT OPERATION
- SYNCHRONOUS PARALLEL ENTRY ON ALL 4 STAGES
- JK INPUTS ON FIRST STAGE
- ASYNCHRONOUS TRUE/COMPLEMENT CONTROL ON ALL OUTPUTS
- STATIC FLIP-FLOP OPERATION; MASTER-SLAVE CONFIGURATION
- BUFFERED INPUTS AND OUTPUTS
- HIGH SPEED 12MHz (Typ.) at $V_{DD} = 10V$
- QUIESCENT CURRENT SPECIF. UP TO 20V
- STANDARDIZED SYMMETRICAL OUTPUT CHARACTERISTICS
- 5V, 10V AND 15V PARAMETRIC RATINGS
- INPUT LEAKAGE CURRENT
 $I_l = 100nA$ (MAX) AT $V_{DD} = 18V$ $T_A = 25^\circ C$
- 100% TESTED FOR QUIESCENT CURRENT
- MEETS ALL REQUIREMENTS OF JEDEC JESD13B "STANDARD SPECIFICATIONS FOR DESCRIPTION OF B SERIES CMOS DEVICES"

DESCRIPTION

The HCF4035B is a monolithic integrated circuit fabricated in Metal Oxide Semiconductor technology available in DIP and SOP packages. This device is a four stage clocked signal serial register with provision for synchronous PARALLEL inputs to each stage and SERIAL inputs to the first stage via JK logic. Register stages 2, 3, and 4 are coupled in a serial D flip-flop configuration when the register is in the serial

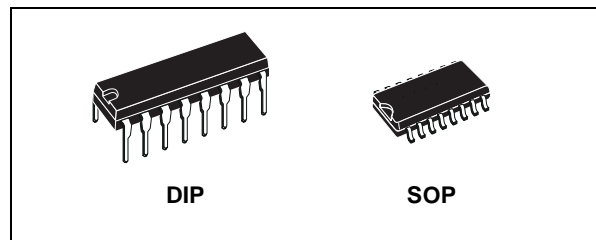

ORDER CODES

PACKAGE	TUBE	T & R
DIP	HCF4035BEY	
SOP	HCF4035BM1	HCF4035M013TR

mode (PARALLEL/SERIAL control low). Parallel entry into each register stage is permitted when the PARALLEL/SERIAL control is high. In the parallel or serial mode information is transferred on positive clock transitions. When the TRUE/COMPLEMENT control is high, the true contents of the register are available at the output terminals. When the TRUE/COMPLEMENT control is low, the outputs are the complements of the data in the register. The TRUE/COMPLEMENT control functions asynchronously with respect to the CLOCK signal. JK input logic is provided on the first stage SERIAL input to minimize logic requirements particularly in counting and sequence generation applications. With JK inputs connected together, the first stage becomes a D flip-flop. An asynchronous common RESET is also provided.

PIN CONNECTION

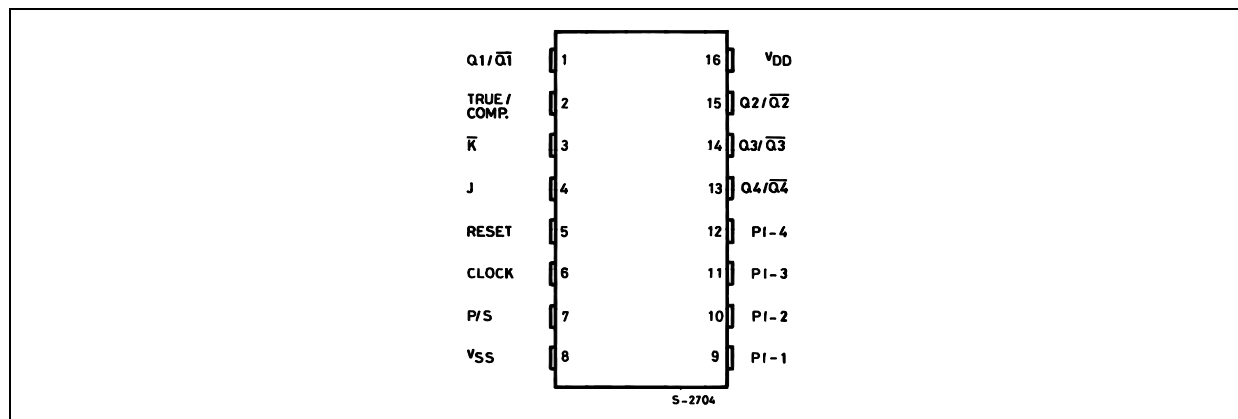

IINPUT EQUIVALENT CIRCUIT

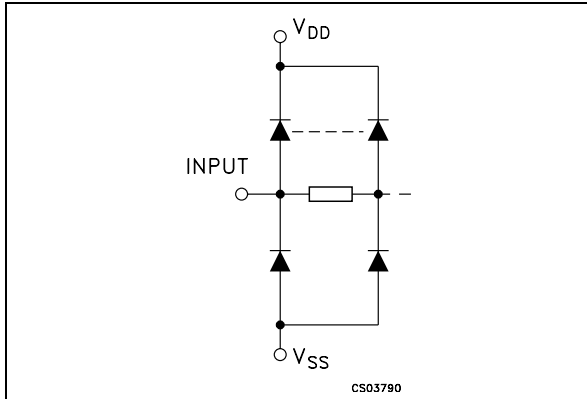

PIN DESCRIPTION

PIN No	SYMBOL	NAME AND FUNCTION
9, 10, 11, 12	PI-1 to PI-4	Parallel Inputs
1, 15, 14, 13	Q1/ $\overline{Q1}$ to Q4/ $\overline{Q4}$	True/Complement Outputs
5	RESET	Reset Input
4, 3	J, K	Serial Inputs
6	CLOCK	Clock Input
7	P/S	Parallel/Serial Control
2	T/C	True/Complement Control
8	V _{SS}	Negative Supply Voltage
16	V _{DD}	Positive Supply Voltage

FUNCTIONAL DIAGRAM

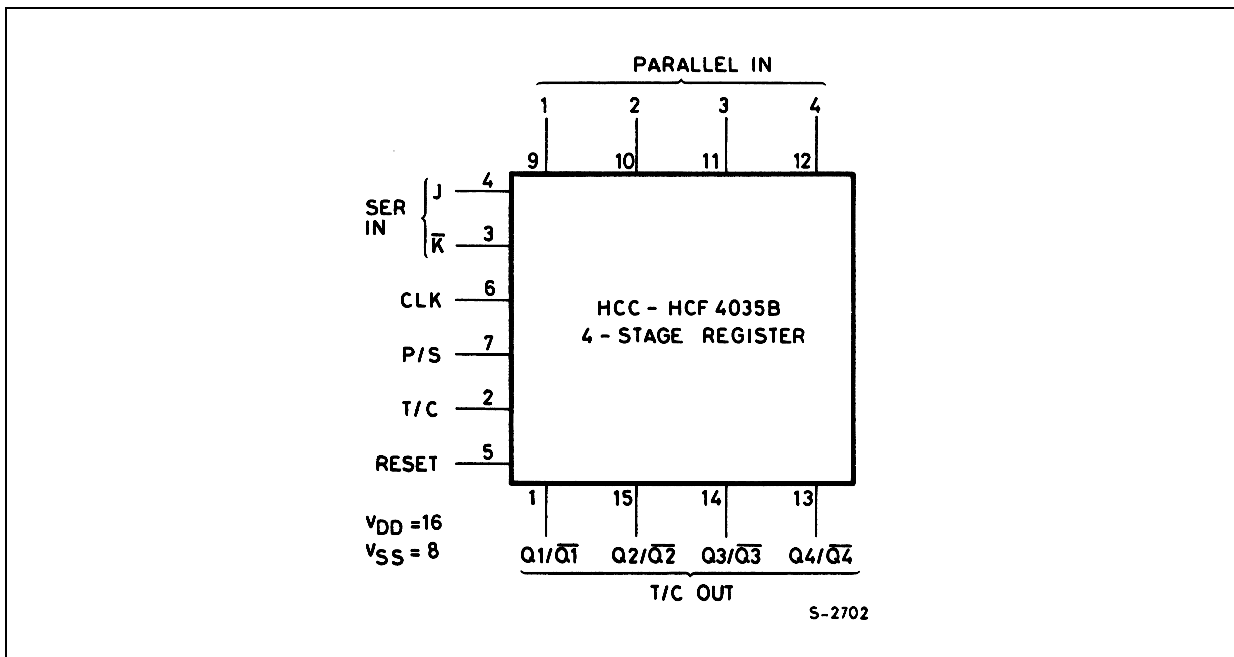

TRUTH TABLE

CLOCK	t _{n-1} (Inputs)			t _n (Outputs)	
	J	\overline{K}	R	Q _{n-1}	Q _n
	L	X	L	L	L
	H	X	L	L	H
	X	L	L	H	L
	H	L	L	Q _{n-1}	$\overline{Q_{n-1}}$ Toggle Mode
	X	H	L	H	H
	X	X	L	Q _{n-1}	Q _{n-1}
X	X	X	H	X	L

X : Don't Care

LOGIC DIAGRAM

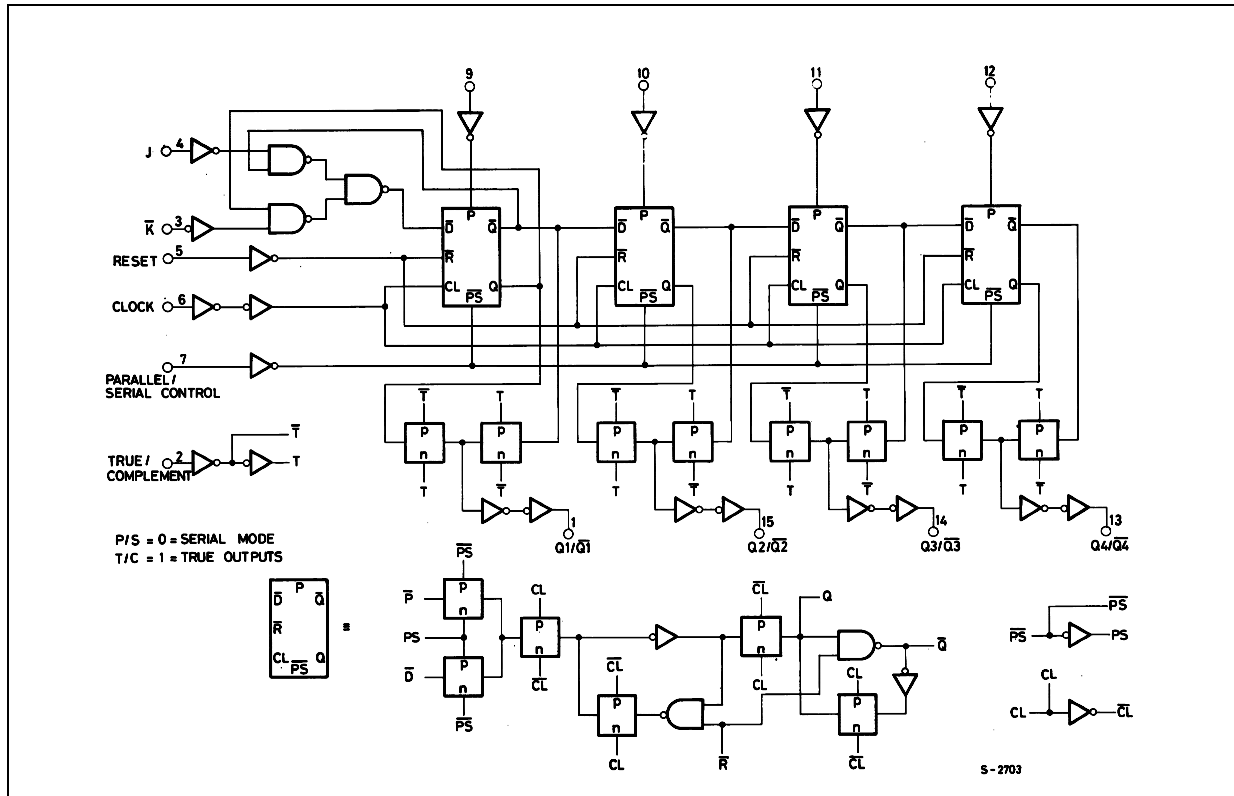

ABSOLUTE MAXIMUM RATINGS

Symbol	Parameter	Value	Unit
V_{DD}	Supply Voltage	-0.5 to +22	V
V_I	DC Input Voltage	-0.5 to $V_{DD} + 0.5$	V
I_I	DC Input Current	± 10	mA
P_D	Power Dissipation per Package	200	mW
	Power Dissipation per Output Transistor	100	mW
T_{op}	Operating Temperature	-55 to +125	$^{\circ}C$
T_{stg}	Storage Temperature	-65 to +150	$^{\circ}C$

Absolute Maximum Ratings are those values beyond which damage to the device may occur. Functional operation under these conditions is not implied.

All voltage values are referred to V_{SS} pin voltage.

RECOMMENDED OPERATING CONDITIONS

Symbol	Parameter	Value	Unit
V_{DD}	Supply Voltage	3 to 20	V
V_I	Input Voltage	0 to V_{DD}	V
T_{op}	Operating Temperature	-55 to 125	$^{\circ}C$

DC SPECIFICATIONS

Symbol	Parameter	Test Condition				Value						Unit	
		V _I (V)	V _O (V)	I _{OL} (μ A)	V _{DD} (V)	T _A = 25°C			-40 to 85°C		-55 to 125°C		
						Min.	Typ.	Max.	Min.	Max.	Min.		Max.
I _L	Quiescent Current	0/5			5		0.04	5		150		150	μ A
		0/10			10		0.04	10		300		300	
		0/15			15		0.04	20		600		600	
		0/20			20		0.08	100		3000		3000	
V _{OH}	High Level Output Voltage	0/5		<1	5	4.95			4.95		4.95		V
		0/10		<1	10	9.95			9.95		9.95		
		0/15		<1	15	14.95			14.95		14.95		
V _{OL}	Low Level Output Voltage	5/0		<1	5		0.05			0.05		0.05	V
		10/0		<1	10		0.05			0.05		0.05	
		15/0		<1	15		0.05			0.05		0.05	
V _{IH}	High Level Input Voltage		0.5/4.5	<1	5	3.5			3.5		3.5		V
			1/9	<1	10	7			7		7		
			1.5/13.5	<1	15	11			11		11		
V _{IL}	Low Level Input Voltage		4.5/0.5	<1	5			1.5		1.5		1.5	V
			9/1	<1	10			3		3		3	
			13.5/1.5	<1	15			4		4		4	
I _{OH}	Output Drive Current	0/5	2.5	<1	5	-1.36	-3.2		-1.1		-1.1		mA
		0/5	4.6	<1	5	-0.44	-1		-0.36		-0.36		
		0/10	9.5	<1	10	-1.1	-2.6		-0.9		-0.9		
		0/15	13.5	<1	15	-3.0	-6.8		-2.4		-2.4		
I _{OL}	Output Sink Current	0/5	0.4	<1	5	0.44	1		0.36		0.36		mA
		0/10	0.5	<1	10	1.1	2.6		0.9		0.9		
		0/15	1.5	<1	15	3.0	6.8		2.4		2.4		
I _I	Input Leakage Current	0/18	Any Input		18		$\pm 10^{-5}$	± 0.1		± 1		± 1	μ A
C _I	Input Capacitance		Any Input				5	7.5					pF

The Noise Margin for both "1" and "0" level is: 1V min. with V_{DD}=5V, 2V min. with V_{DD}=10V, 2.5V min. with V_{DD}=15V

DYNAMIC ELECTRICAL CHARACTERISTICS ($T_{amb} = 25^{\circ}\text{C}$, $C_L = 50\text{pF}$, $R_L = 200\text{K}\Omega$, $t_r = t_f = 20\text{ ns}$)

Symbol	Parameter	Test Condition		Value (*)			Unit
		V_{DD} (V)		Min.	Typ.	Max.	
CLOCKED OPERATION							
t_{PLH} t_{PHL}	Propagation Delay Time	5			250	500	ns
		10			100	200	
		15			75	150	
t_{THL} t_{TLH}	Transition Time	5			100	200	ns
		10			50	100	
		15			40	80	
f_{MAX}	Maximum Clock Input Frequency	5		2	4		MHz
		10		6	12		
		15		8	16		
t_W	Clock Pulse Width	5			100	200	ns
		10			45	90	
		15			30	60	
t_r , t_f	Clock Input Rise or Fall Time	5			15		μs
		10			15		
		15			15		
t_{setup}	Data Setup Time J/K lines	5			110	220	ns
		10			40	80	
		15			30	60	
t_{setup}	Data Setup Time Parallel In Lines	5			70	140	ns
		10			25	50	
		15			20	40	
RESET OPERATION							
t_{PLH} t_{PHL}	Propagation Delay Time	5			230	460	ns
		10			100	200	
		15			80	160	
t_W	Reset Pulse Width	5			125	250	ns
		10			55	110	
		15			40	40	

(*) Typical temperature coefficient for all V_{DD} value is 0.3 %/°C.

TYPICAL APPLICATIONS

Binary To BCD Converter

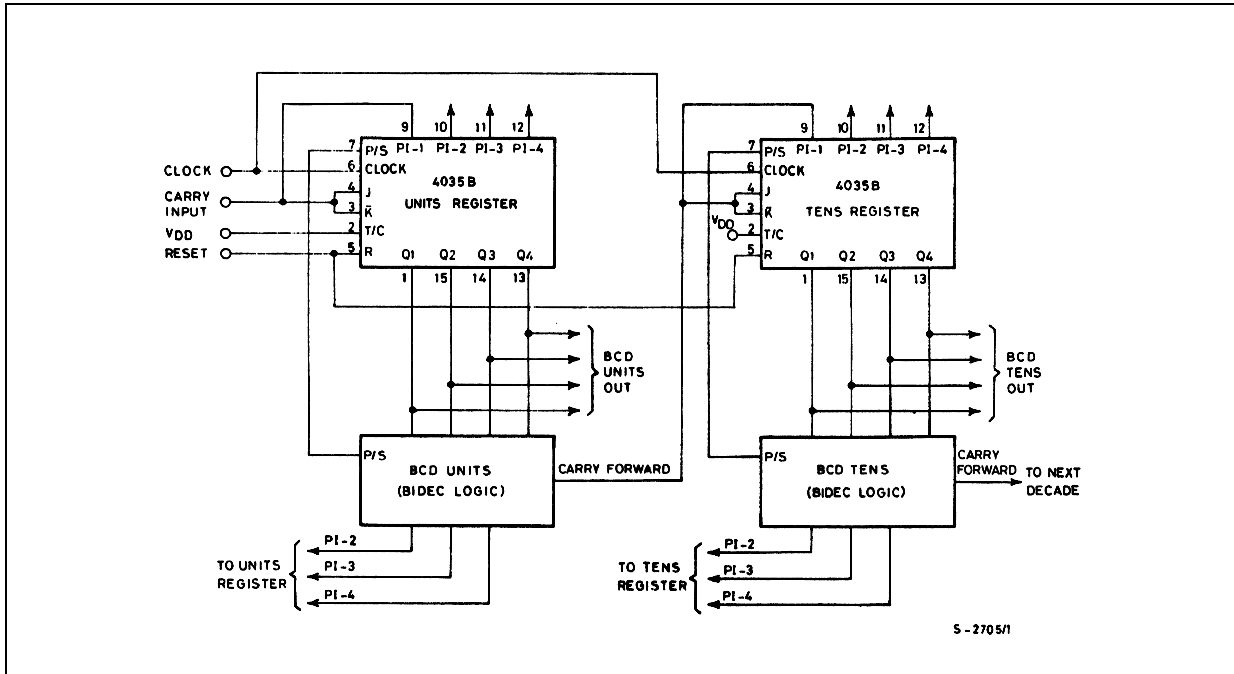

Biddec Logic

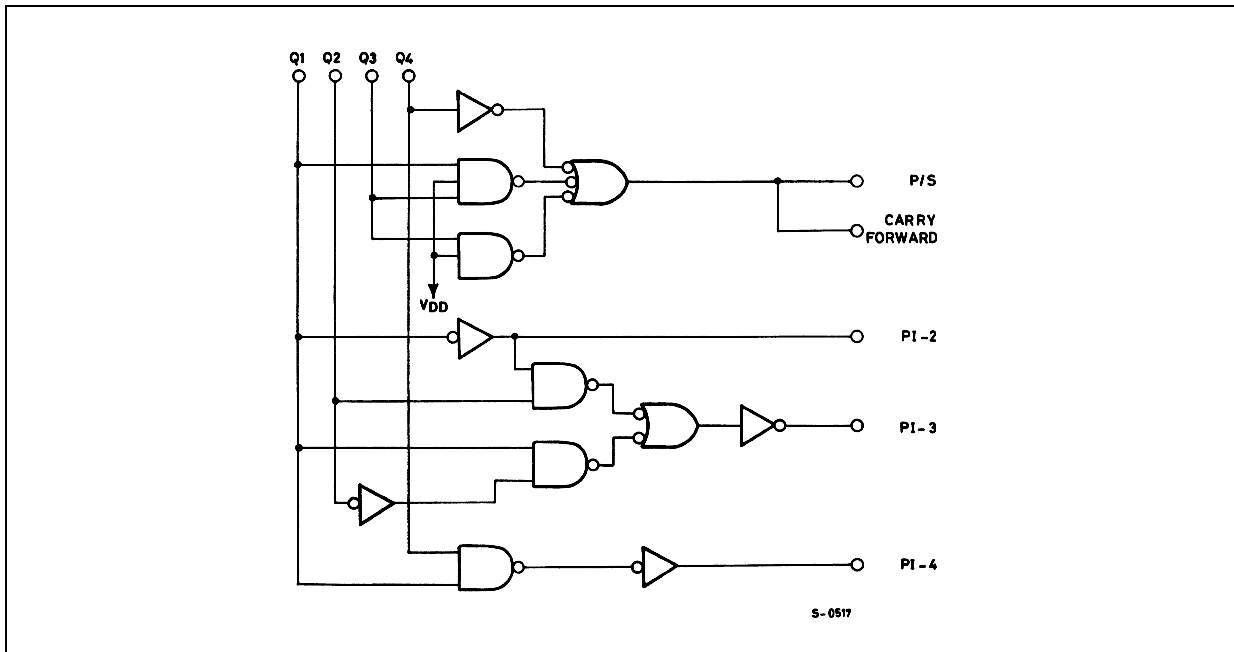

DOUBLE SEQUENCE GENERATOR

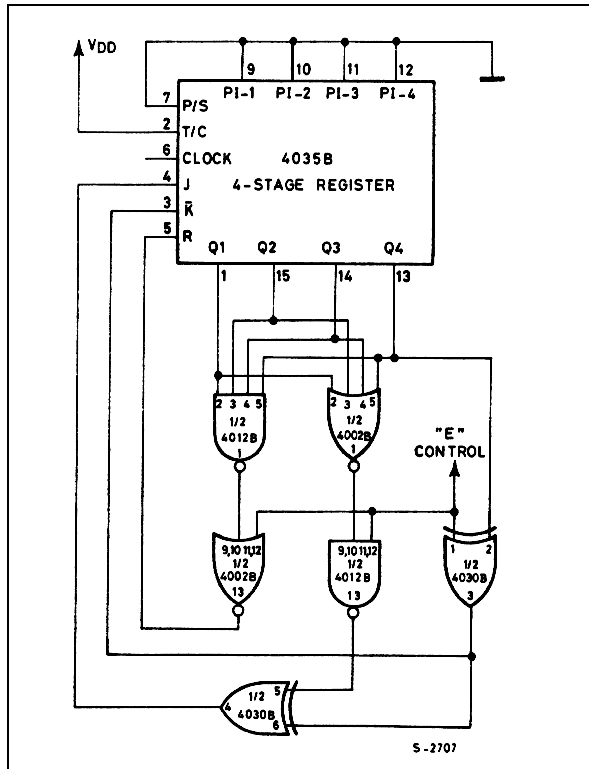

STATE SEQUENCES

Using a control line (E) two different state sequences can be generated. For example, suppose the following two sequences are desirated on command (control line E)

	Control = E = 0					1			
	Q ₁	Q ₂	Q ₃	Q ₄		Q ₁	Q ₂	Q ₃	Q ₄
	A	B	C	D		A	B	C	D
0	0	0	0	0	15	1	1	1	1
1	1	0	0	0	14	0	0	1	1
2	0	1	0	0	13	1	0	1	1
5	1	0	1	0	10	0	1	0	1
10	0	1	0	1	5	1	0	1	0
4	0	0	1	0	11	1	1	0	1
9	1	0	0	1	6	0	1	1	0
3	1	1	0	0	12	0	0	1	1
6	0	1	1	0	9	1	0	0	1
13	1	0	1	1	2	0	1	0	0
11	1	1	0	1	4	0	0	1	0
7	1	1	1	0	8	0	0	0	1
14	0	1	1	1	1	1	0	0	0
12	0	0	1	1	3	1	1	0	0
8	0	0	0	1	7	1	1	1	0

SHIFT LEFT/SHIFT RIGHT REGISTER

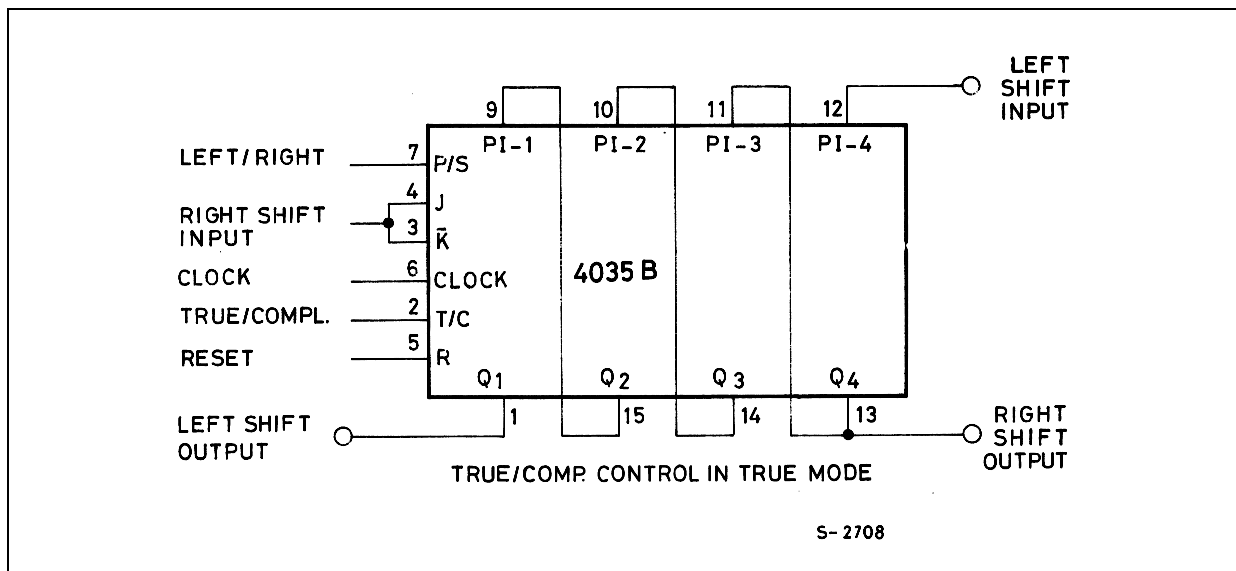

TEST CIRCUIT

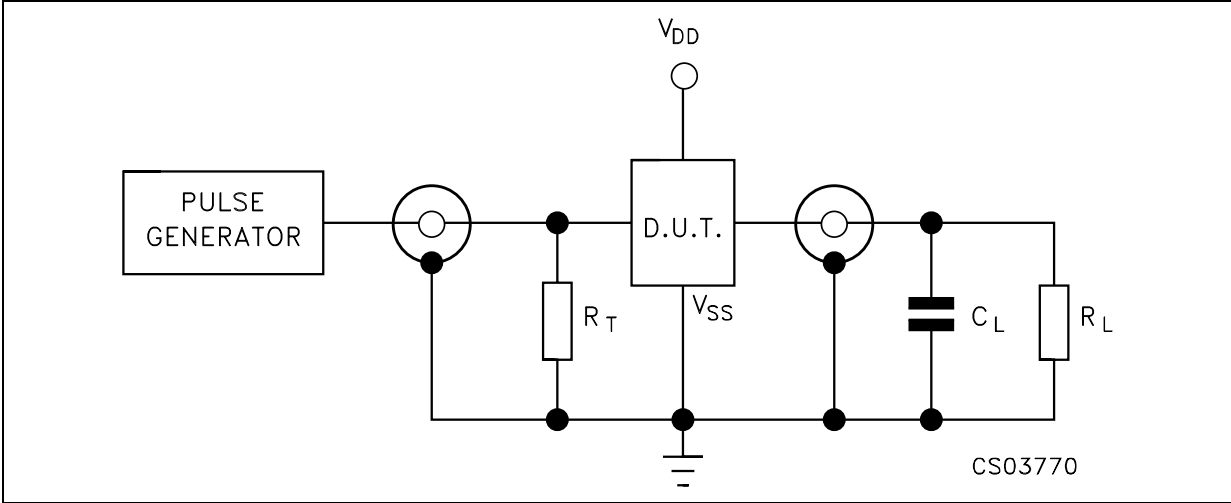

$C_L = 50\text{pF}$ or equivalent (includes jig and probe capacitance)
 $R_L = 200\text{K}\Omega$
 $R_T = Z_{OUT}$ of pulse generator (typically 50Ω)

Plastic DIP-16 (0.25) MECHANICAL DATA

DIM.	mm.			inch		
	MIN.	TYP	MAX.	MIN.	TYP.	MAX.
a1	0.51			0.020		
B	0.77		1.65	0.030		0.065
b		0.5			0.020	
b1		0.25			0.010	
D			20			0.787
E		8.5			0.335	
e		2.54			0.100	
e3		17.78			0.700	
F			7.1			0.280
I			5.1			0.201
L		3.3			0.130	
Z			1.27			0.050

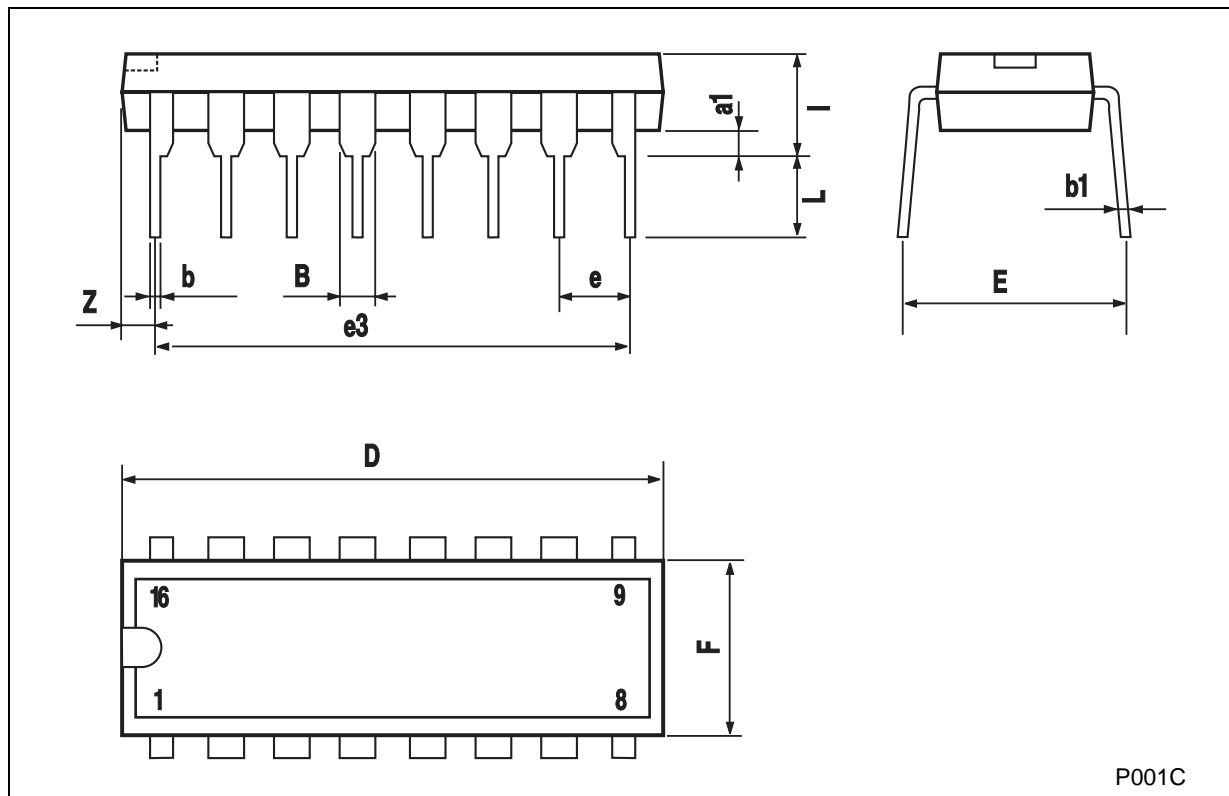

SO-16 MECHANICAL DATA

DIM.	mm.			inch		
	MIN.	TYP.	MAX.	MIN.	TYP.	MAX.
A			1.75			0.068
a1	0.1		0.2	0.003		0.007
a2			1.65			0.064
b	0.35		0.46	0.013		0.018
b1	0.19		0.25	0.007		0.010
C		0.5			0.019	
c1	45° (typ.)					
D	9.8		10	0.385		0.393
E	5.8		6.2	0.228		0.244
e		1.27			0.050	
e3		8.89			0.350	
F	3.8		4.0	0.149		0.157
G	4.6		5.3	0.181		0.208
L	0.5		1.27	0.019		0.050
M			0.62			0.024
S	8° (max.)					

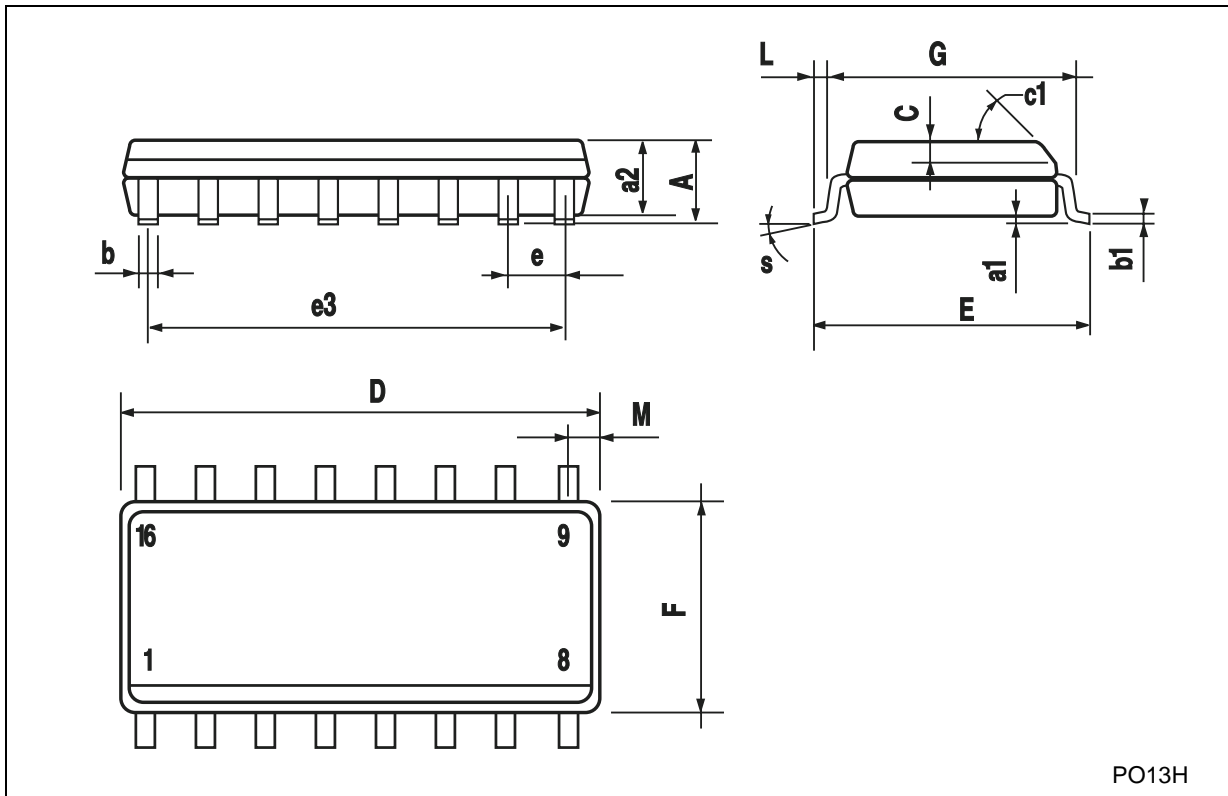

PO13H

Information furnished is believed to be accurate and reliable. However, STMicroelectronics assumes no responsibility for the consequences of use of such information nor for any infringement of patents or other rights of third parties which may result from its use. No license is granted by implication or otherwise under any patent or patent rights of STMicroelectronics. Specifications mentioned in this publication are subject to change without notice. This publication supersedes and replaces all information previously supplied. STMicroelectronics products are not authorized for use as critical components in life support devices or systems without express written approval of STMicroelectronics.

© The ST logo is a registered trademark of STMicroelectronics

© 2001 STMicroelectronics - Printed in Italy - All Rights Reserved
STMicroelectronics GROUP OF COMPANIES

Australia - Brazil - China - Finland - France - Germany - Hong Kong - India - Italy - Japan - Malaysia - Malta - Morocco
Singapore - Spain - Sweden - Switzerland - United Kingdom

© <http://www.st.com>





LittleDiode supplies new, hard to find or obsolete electronic components and semiconductors all over the world.

With over two million different components listed you are sure to find the part you need.

Feel free to visit us today at our online store:

LittleDiode.com

Looking forward to providing you with the best possible service.