

DUAL MONOSTABLE MULTIVIBRATOR

- RETRIGGERABLE/RESETTABLE CAPABILITY
- TRIGGER AND RESET PROPAGATION DELAYS INDEPENDENT OF R_X , C_X
- TRIGGERING FROM LEADING OR TRAILING EDGE
- Q AND \bar{Q} BUFFERED OUTPUT AVAILABLE
- SEPARATE RESETS
- WIDE RANGE OF OUTPUT PULSE WIDTHS
- QUIESCENT CURRENT SPECIFIED UP TO 20V
- 5V, 10V AND 15V PARAMETRIC RATINGS
- INPUT LEAKAGE CURRENT
 $I_l = 100\text{nA (MAX) AT } V_{DD} = 18\text{V } T_A = 25^\circ\text{C}$
- 100% TESTED FOR QUIESCENT CURRENT
- MEETS ALL REQUIREMENTS OF JEDEC JESD13B "STANDARD SPECIFICATIONS FOR DESCRIPTION OF B SERIES CMOS DEVICES"

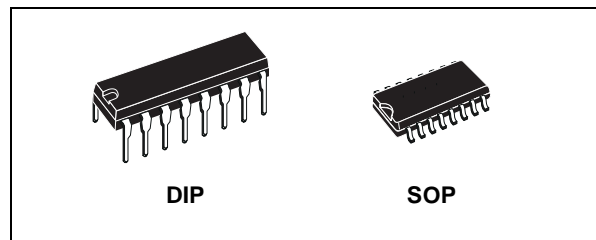

ORDER CODES

PACKAGE	TUBE	T & R
DIP	HCF4098BEY	
SOP	HCF4098BM1	HCF4098M013TR

wide range of output pulse widths from the Q and \bar{Q} terminals. The time delay from trigger input to output transition (trigger propagation delay) and the time delay from reset input to output transition (reset propagation delay) and the time delay from reset input to output transition (reset propagation delay) are independent of R_X and C_X . Leading edge triggering (+TR) and trailing edge triggering (-TR) inputs are provided for triggering from either edge of an input pulse. An unused +TR input should be tied to V_{SS} . An unused -TR input should be tied to V_{DD} . A RESET (on low level) is provided for immediate termination of the output pulse or to prevent output pulses when power is turned on.

DESCRIPTION

The HCF4098B is a monolithic integrated circuit fabricated in Metal Oxide Semiconductor technology available in DIP and SOP packages. The HCF4098B dual precision monostable multivibrator provides stable retriggerable/resettable one-shot operation for any fixed voltage timing application. An external resistor (R_X) and an external capacitor (C_X) control the timing for the circuit. Adjustment of R_X and C_X provides a

PIN CONNECTION

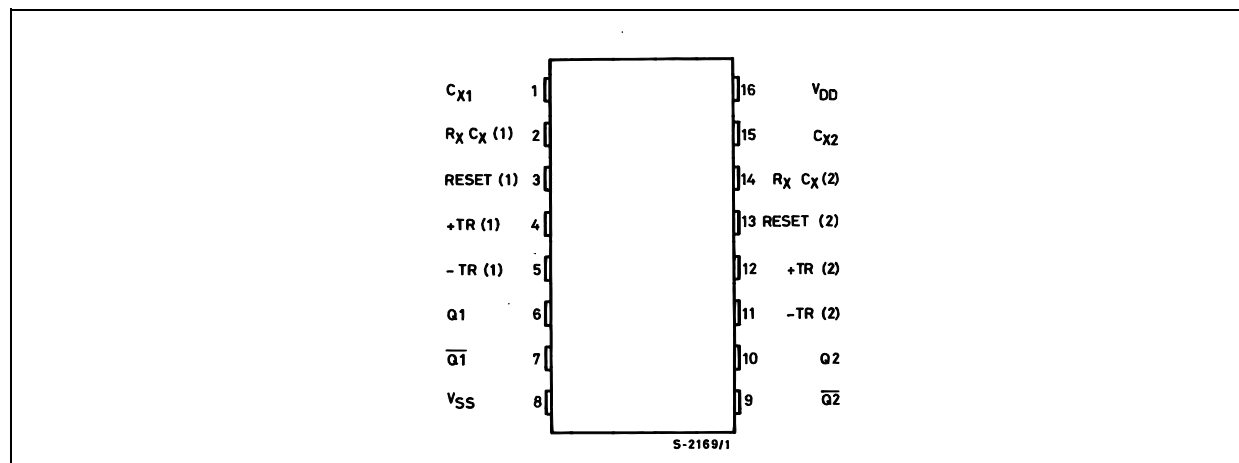

HCF4098B

An unused RESET input should be tied to V_{DD} . However, if an entire section of the HCF4098B is not used, its reset should be tied to V_{SS} (see table 1). In normal operation the circuit triggers (extends the output pulse one period) on the application of each new trigger pulse. For operation in the non-retiggerable mode, \bar{Q} is connected to -TR when leading edge triggering (+TR) is used or Q is connected to +TR when trailing edge triggering (-TR) is used. The time period (T) for this

IINPUT EQUIVALENT CIRCUIT

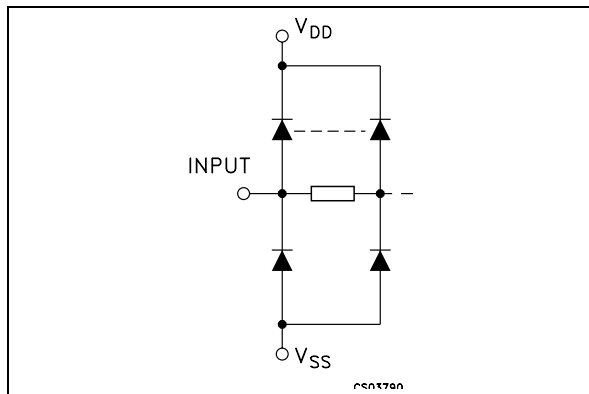

multivibrator can be calculated by: $T = 1/2 R_X C_X$ for $C_X \geq 0.01\mu\text{F}$. The min. value of external resistance, R_X , is $5\text{K}\Omega$. The max. values of external capacitance, C_X , is $100\mu\text{F}$. The output pulse width has variations of $\pm 2.5\%$ typically, over the temperature range of -55°C to 125°C for $C_X = 1000\text{pF}$ and $R_X = 100\text{K}\Omega$. For power supply variation of $\pm 5\%$ typically, for $V_{DD} = 10\text{V}$ and 15V and $\pm 1\%$ typically for $V_{DD} = 5\text{V}$ at $C_X = 1000\text{pF}$ and $R_X = 5\text{K}\Omega$.

PIN DESCRIPTION

PIN No	SYMBOL	NAME AND FUNCTION
4, 12	+TR	Leading Trigger Inputs
5, 11	-TR	Trailing Trigger Inputs
3, 13	RESET	Reset Inputs
1, 15	C_X1, C_X2	External Capacitors
2, 14	$R_X C_X1$ $R_X C_X2$	External resistors to Vdd
6, 7	Q1, $\bar{Q}1$	Outputs Mono 1
10, 9	Q2, $\bar{Q}2$	Outputs Mono 2
8	V_{SS}	Negative Supply Voltage
16	V_{DD}	Positive Supply Voltage

FUNCTIONAL DIAGRAM

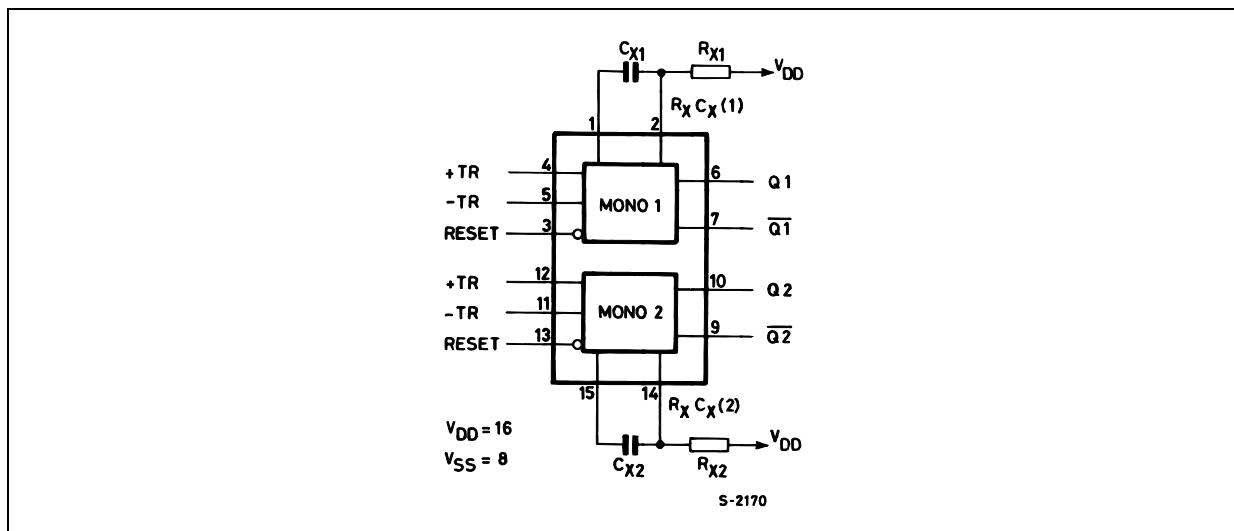
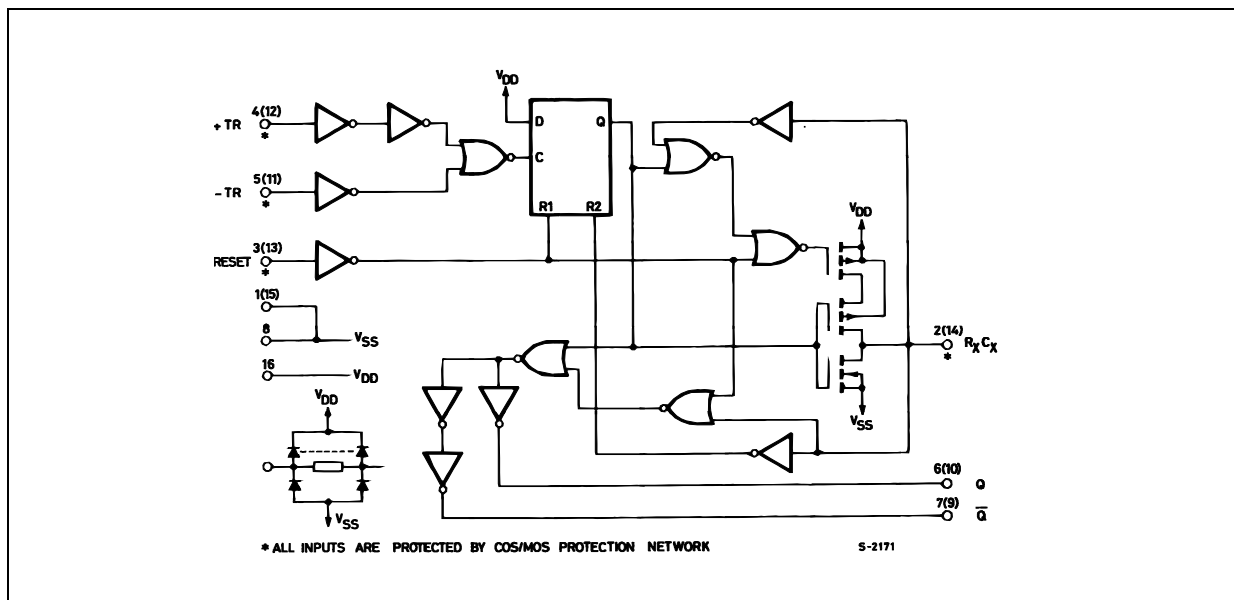

TABLE 1 : Functional Terminal Connections

FUNCTION	V _{DD} to Term. N°		V _{SS} to Term. N°		Input Pulse to Term. N°		Other Connections	
	Mono (1)	Mono (2)	Mono (1)	Mono (2)	Mono (1)	Mono (2)	Mono (1)	Mono (2)
Leading Edge Trigger/Retriggerable	3, 5	11, 13			4	12		
Leading Edge Trigger/Non Retriggerable	3	13			4	12	5, 7	11, 9
Trailing Edge Trigger/Retriggerable	3	13	4	12	5	11		
Trailing Edge Trigger/Non Retriggerable	3	13			5	11	4, 6	12, 10
Unused Section	5	11	3, 4	12, 13				

A Retriggerable one-shot multivibrator has an output pulse width which is extended on full time period (T) after application of the last trigger pulse.
 A Non-Retriggerable one-shot multivibrator has a time period (T) referenced from the application of the first trigger pulse.

LOGIC DIAGRAM



ABSOLUTE MAXIMUM RATINGS

Symbol	Parameter	Value	Unit
V _{DD}	Supply Voltage	-0.5 to +22	V
V _I	DC Input Voltage	-0.5 to V _{DD} + 0.5	V
I _I	DC Input Current	± 10	mA
P _D	Power Dissipation per Package	200	mW
	Power Dissipation per Output Transistor	100	mW
T _{op}	Operating Temperature	-55 to +125	°C
T _{stg}	Storage Temperature	-65 to +150	°C

Absolute Maximum Ratings are those values beyond which damage to the device may occur. Functional operation under these conditions is not implied.
 All voltage values are referred to V_{SS} pin voltage.

RECOMMENDED OPERATING CONDITIONS

Symbol	Parameter	Value	Unit
V _{DD}	Supply Voltage	3 to 20	V
V _I	Input Voltage	0 to V _{DD}	V
T _{op}	Operating Temperature	-55 to 125	°C

DC SPECIFICATIONS

Symbol	Parameter	Test Condition				Value						Unit	
		V _I (V)	V _O (V)	I _o (μA)	V _{DD} (V)	T _A = 25°C			-40 to 85°C		-55 to 125°C		
						Min.	Typ.	Max.	Min.	Max.	Min.		Max.
I _L	Quiescent Current	0/5			5		0.02	1		30		30	μA
		0/10			10		0.02	2		60		60	
		0/15			15		0.02	4		120		120	
		0/20			20		0.04	20		600		600	
V _{OH}	High Level Output Voltage	0/5		<1	5	4.95			4.95		4.95		V
		0/10		<1	10	9.95			9.95		9.95		
		0/15		<1	15	14.95			14.95		14.95		
V _{OL}	Low Level Output Voltage	5/0		<1	5		0.05			0.05		0.05	V
		10/0		<1	10		0.05			0.05		0.05	
		15/0		<1	15		0.05			0.05		0.05	
V _{IH}	High Level Input Voltage		0.5/4.5	<1	5	3.5			3.5		3.5		V
			1/9	<1	10	7			7		7		
			1.5/13.5	<1	15	11			11		11		
V _{IL}	Low Level Input Voltage		4.5/0.5	<1	5			1.5		1.5		1.5	V
			9/1	<1	10			3		3		3	
			13.5/1.5	<1	15			4		4		4	
I _{OH}	Output Drive Current	0/5	2.5	<1	5	-1.6	-3.2		-1.3		-1.3		mA
		0/5	4.6	<1	5	-0.51	-1		-0.42		-0.42		
		0/10	9.5	<1	10	-1.3	-2.6		-1.1		-1.1		
		0/15	13.5	<1	15	-3.4	-6.8		-2.8		-2.8		
I _{OL}	Output Sink Current	0/5	0.4	<1	5	-0.51	1		-0.42		-0.42		mA
		0/10	0.5	<1	10	-1.3	2.6		-1.1		-1.1		
		0/15	1.5	<1	15	-3.4	6.8		-2.8		-2.8		
I _I	Input Leakage Current	0/18	Any Input		18		±10 ⁻⁵	±0.1		±1		±1	μA
C _I	Input Capacitance		Any Input				5	7.5					pF

The Noise Margin for both "1" and "0" level is: 1V min. with V_{DD}=5V, 2V min. with V_{DD}=10V, 2.5V min. with V_{DD}=15V

DYNAMIC ELECTRICAL CHARACTERISTICS ($T_{amb} = 25^{\circ}\text{C}$, $C_L = 50\text{pF}$, $R_L = 200\text{K}\Omega$, $t_r = t_f = 20\text{ ns}$)

Symbol	Parameter	Test Condition			Value (*)			Unit
		R_X (K Ω)	C_X (pF)	V_{DD} (V)	Min.	Typ.	Max.	
t_{PLH} t_{PHL}	Propagation Delay Time +TR or -TR to Q or \bar{Q}	5 to 10000	≥ 15	5		250	500	ns
				10		125	250	
				15		100	200	
t_{WH} t_{WL}	Trigger Pulse Width	5 to 10000	≥ 15	5	140	70		ns
				10	60	30		
				15	40	20		
t_{TLH}	Transition Time	5 to 10000	≥ 15	5		100	200	ns
				10		50	100	
				15		40	80	
t_{THL}	Transition Time	5 to 10000	15 to 10000	5		100	200	ns
				10		50	100	
				15		40	80	
		5 to 10000	0.01 μF to 0.1 μF	5		150	300	
				10		75	150	
				15		65	130	
		5 to 10000	0.1 μF to 1 μF	5		250	500	
				10		150	300	
				15		80	160	
t_{PLH} t_{PHL}	Propagation Delay Time (Reset)	5 to 10000	≥ 15	5		225	450	ns
				10		125	250	
				15		75	150	
t_{WR}	Pulse Width (reset)	100	15	5	200	100		ns
				10	80	40		
				15	60	30		
			1000	5	1200	600		
				10	600	300		
				15	500	250		
		0.1 μF	5	50	250		μs	
			10	30	15			
			15	20	10			
t_r , t_f (TR)	Rise or Fall Time (trigger)		5 to 15				100	μs
	Pulse Width Match Between Circuits in Same Package	10	10000	5		5	10	%
				10		7.5	15	
				15		7.5	15	

(*) Typical temperature coefficient for all V_{DD} value is 0.3 %/ $^{\circ}\text{C}$.

TEST CIRCUIT

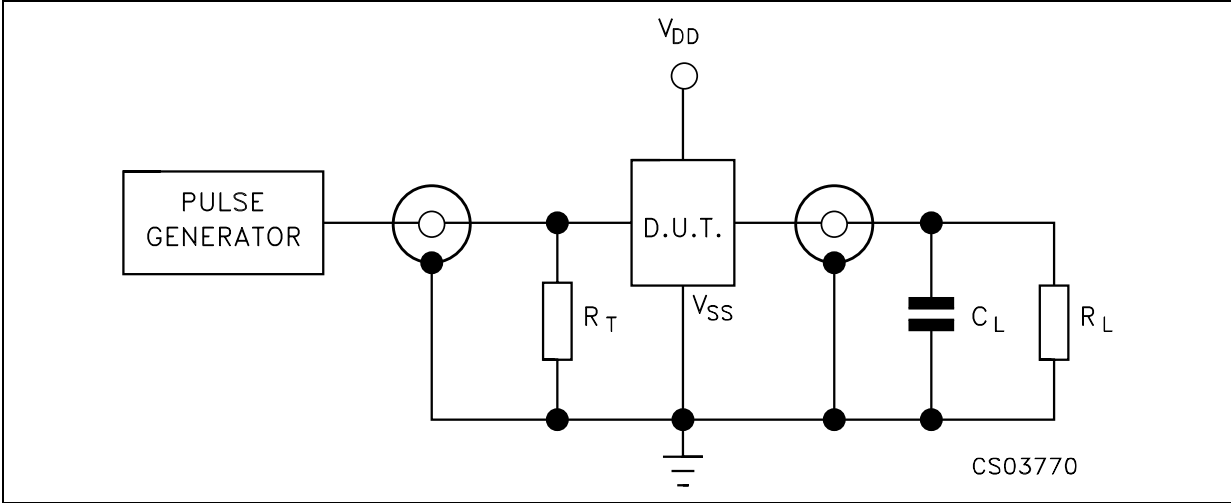

$C_L = 50\text{pF}$ or equivalent (includes jig and probe capacitance)
 $R_L = 200\text{K}\Omega$
 $R_T = Z_{OUT}$ of pulse generator (typically 50Ω)

Plastic DIP-16 (0.25) MECHANICAL DATA

DIM.	mm.			inch		
	MIN.	TYP	MAX.	MIN.	TYP.	MAX.
a1	0.51			0.020		
B	0.77		1.65	0.030		0.065
b		0.5			0.020	
b1		0.25			0.010	
D			20			0.787
E		8.5			0.335	
e		2.54			0.100	
e3		17.78			0.700	
F			7.1			0.280
I			5.1			0.201
L		3.3			0.130	
Z			1.27			0.050

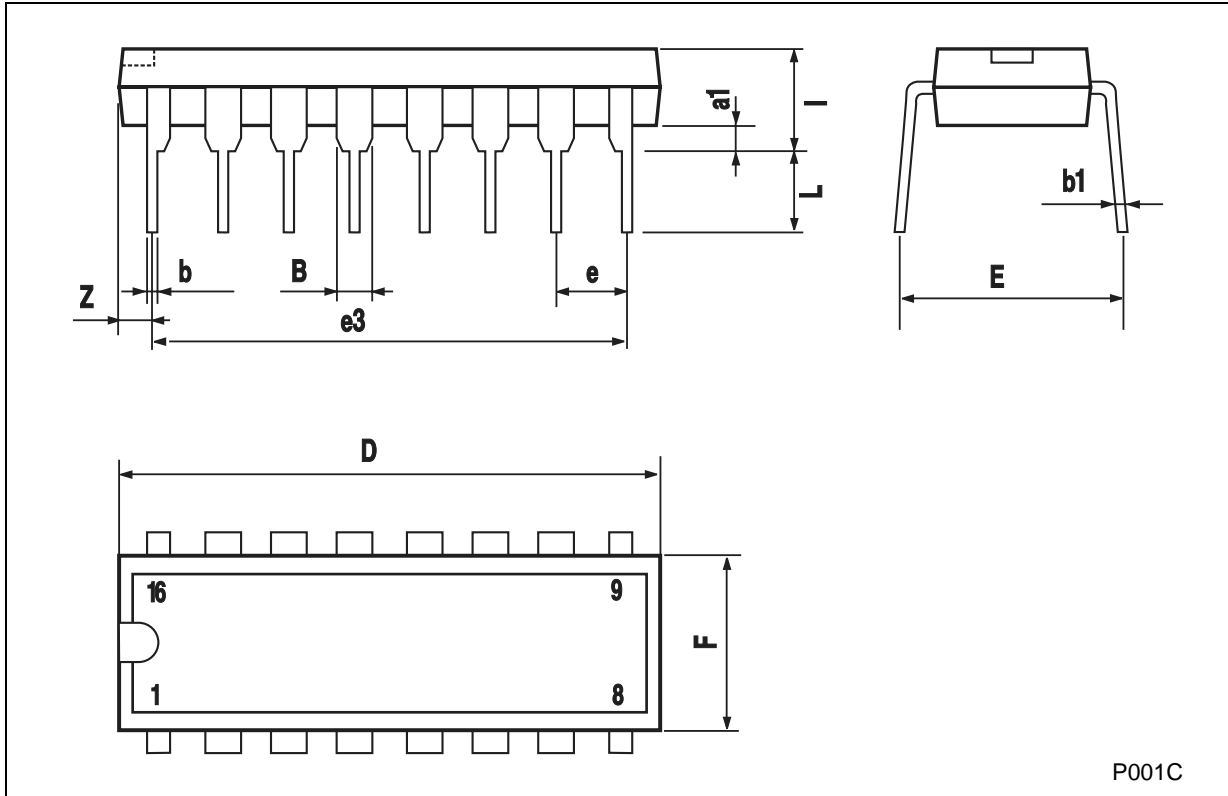

P001C



SO-16 MECHANICAL DATA

DIM.	mm.			inch		
	MIN.	TYP.	MAX.	MIN.	TYP.	MAX.
A			1.75			0.068
a1	0.1		0.2	0.003		0.007
a2			1.65			0.064
b	0.35		0.46	0.013		0.018
b1	0.19		0.25	0.007		0.010
C		0.5			0.019	
c1	45° (typ.)					
D	9.8		10	0.385		0.393
E	5.8		6.2	0.228		0.244
e		1.27			0.050	
e3		8.89			0.350	
F	3.8		4.0	0.149		0.157
G	4.6		5.3	0.181		0.208
L	0.5		1.27	0.019		0.050
M			0.62			0.024
S	8° (max.)					

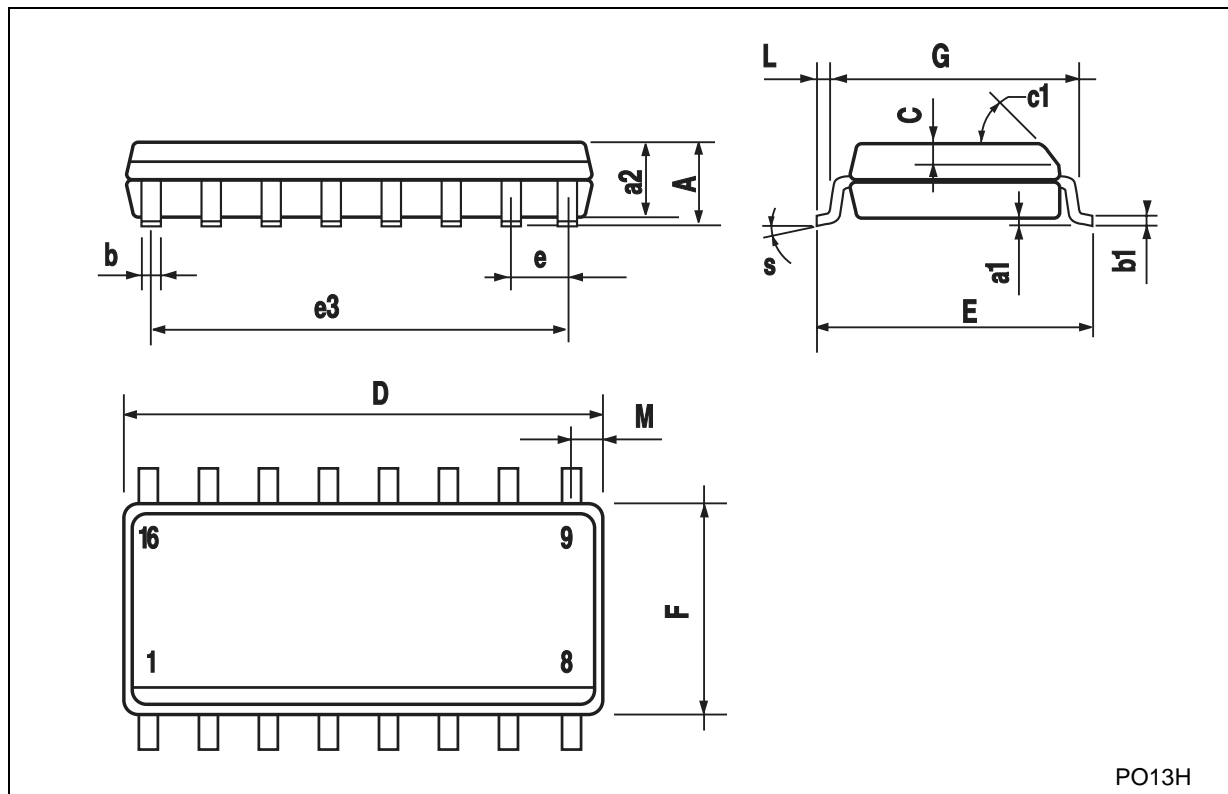

PO13H

Information furnished is believed to be accurate and reliable. However, STMicroelectronics assumes no responsibility for the consequences of use of such information nor for any infringement of patents or other rights of third parties which may result from its use. No license is granted by implication or otherwise under any patent or patent rights of STMicroelectronics. Specifications mentioned in this publication are subject to change without notice. This publication supersedes and replaces all information previously supplied. STMicroelectronics products are not authorized for use as critical components in life support devices or systems without express written approval of STMicroelectronics.

© The ST logo is a registered trademark of STMicroelectronics

© 2001 STMicroelectronics - Printed in Italy - All Rights Reserved
STMicroelectronics GROUP OF COMPANIES

Australia - Brazil - China - Finland - France - Germany - Hong Kong - India - Italy - Japan - Malaysia - Malta - Morocco
Singapore - Spain - Sweden - Switzerland - United Kingdom

© <http://www.st.com>



LittleDiode supplies new, hard to find or obsolete electronic components and semiconductors all over the world.

With over two million different components listed you are sure to find the part you need.

Feel free to visit us today at our online store:

LittleDiode.com

Looking forward to providing you with the best possible service.