

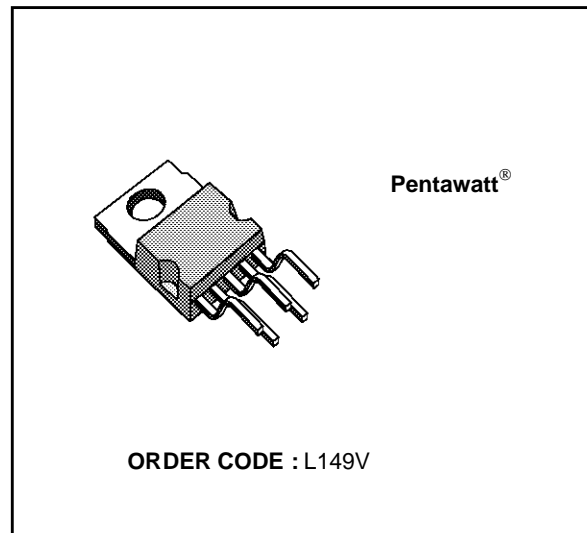
## 4A LINEAR DRIVER

- HIGH OUTPUT CURRENT (4A peak)
- HIGH CURRENT GAIN (10.000 typ.)
- OPERATION UP TO  $\pm 20$  V
- THERMAL PROTECTION
- SHORT CIRCUIT PROTECTION
- OPERATION WITHIN SOA
- HIGH SLEW-RATE (30 V/ $\mu$ s)

### DESCRIPTION

The L149 is a general purpose power booster in Pentawatt<sup>®</sup> package consisting of a quasi-complementary darlington output stage with the associated biasing system an inhibit facility.

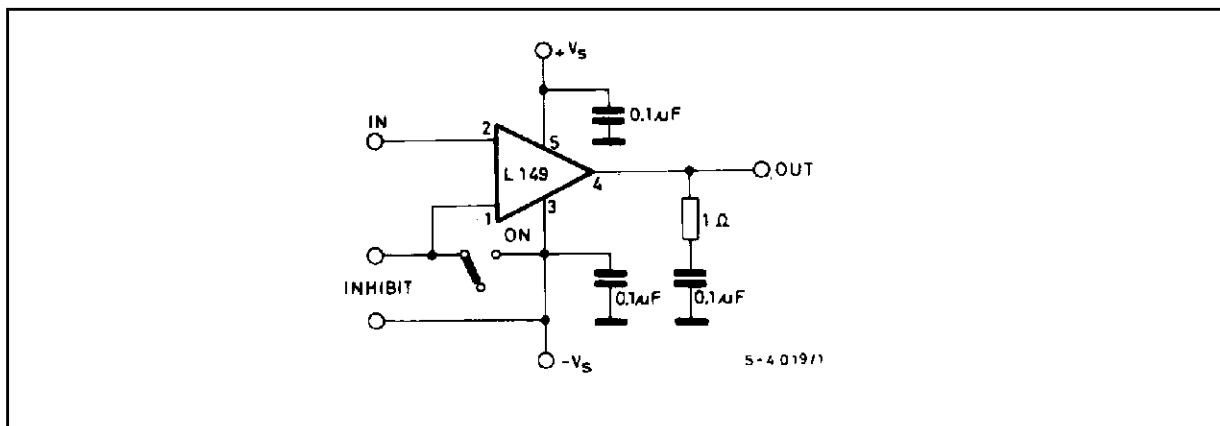
The device is particularly suited for use with an operational amplifier inside a closed loop configuration to increase output current.



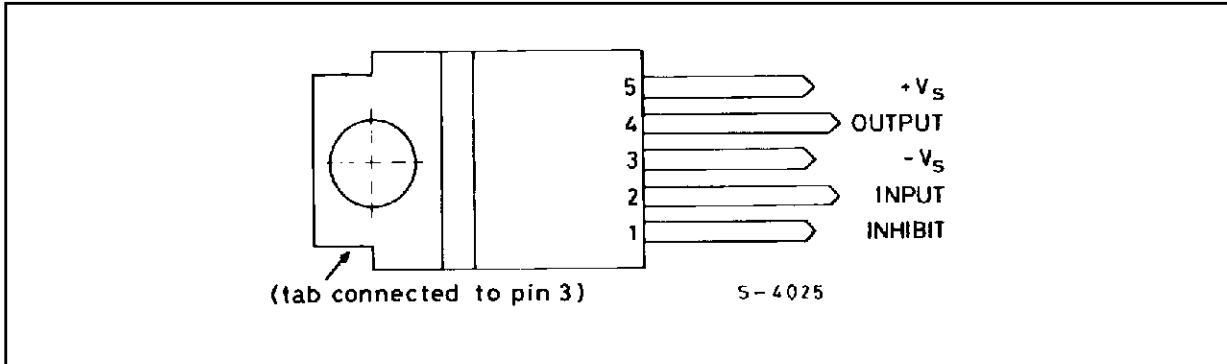
### ABSOLUTE MAXIMUM RATINGS

Symbol	Parameter	Value	Unit
$V_s$	Supply Voltage	$\pm 20$	V
$V_i$	Input Voltage		$V_s$
$V_5 - V_4$	Upper Power Transistor VCE	40	V
$V_4 - V_3$	Lower Power Transistor $V_{CE}$	40	V
$I_o$	DC Output Current	3	A
$I_o$	Peak Output Current (internally limited)	4	A
$V_{INH}$	Input Inhibit Voltage	- $V_s + 5$ - $V_s - 1.5$	V V
$P_{tot}$	Total Power Dissipation at $T_{case} = 75^\circ C$ )	25	W

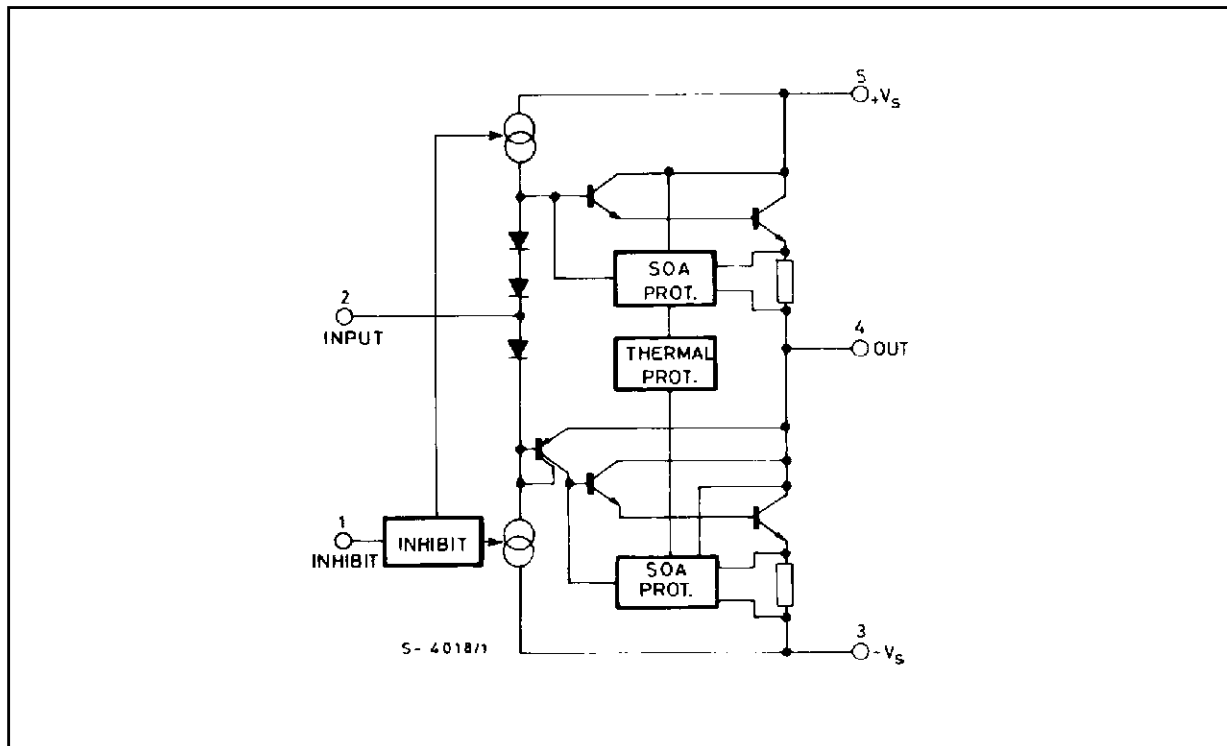
### TEST CIRCUIT



CONNECTION DIAGRAM (top view)



SCHEMATIC DIAGRAM



## THERMAL DATA

Symbol	Parameter	Value	Unit
Rth-j-case	Thermal resistance junction-case	max 3	°C/W

ELECTRICAL CHARACTERISTICS ( $T_j = 25^\circ\text{C}$ ,  $V_s = \pm 16\text{V}$ )

Symbol	Parameter	Test conditions	Min.	Typ.	Max.	Unit
$V_s$	Supply Voltage				$\pm 20$	V
$I_d$	Quiescent Drain Current	$V_s = \pm 16\text{V}$		30		mA
$I_{in}$	Input current	$V_s = \pm 16\text{V}$ $V_i = 0\text{V}$		200	400	$\mu\text{A}$
$h_{FE}$	DC current drain	$V_s = \pm 16\text{V}$ $I_o = 3\text{A}$	6000	10000		-
$G_V$	Voltage gain	$V_s = \pm 16\text{V}$ $I_o = 1.5\text{A}$		1		-
$V_{CEsat}$	Saturation voltage (for each transistor)	$I_o = 3\text{A}$			3.5	V
$V_{os}$	Input offset voltage	$V_s = \pm 16\text{V}$			0.3	V
$V_{INH}$	Inhibit input voltage (pins 1-3)	ON condition			$\pm 0.3$	V
		OFF condition	$\pm 1.8$			
$R_{INH}$	Inhibit input resistance			2.0		$\text{K}\Omega$
SR	Slew rate			30		$\text{V}/\mu\text{s}$
B	Power bandwidth	$V_o = \pm 10\text{V}$ , $d = 1\%$ , $R_L = 8\Omega$		200		KHz

## APPLICATION INFORMATION

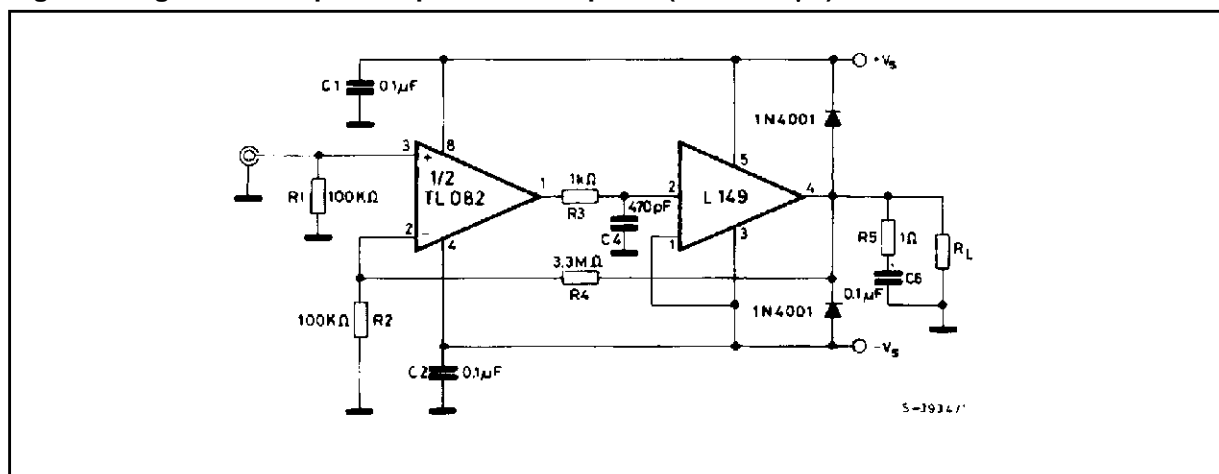
Figure 1. High slew-rate power operational amplifier (SR =  $13\text{V}/\mu\text{s}$ )

Figure 2. Maximum saturation voltage vs. output current.

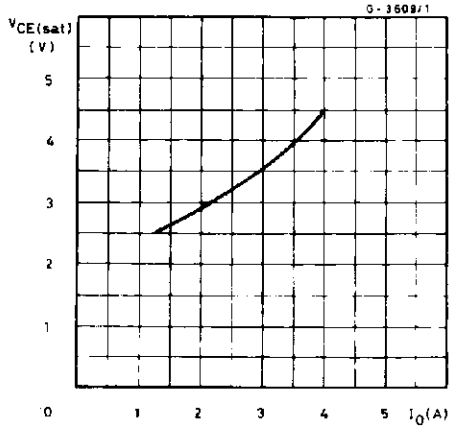


Figure 3. Current limiting characteristics.

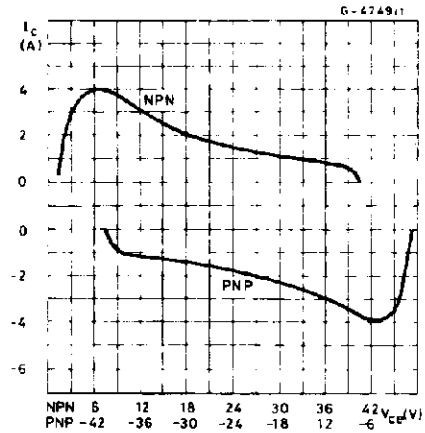


Figure 4: Supply voltage rejection vs. frequency.

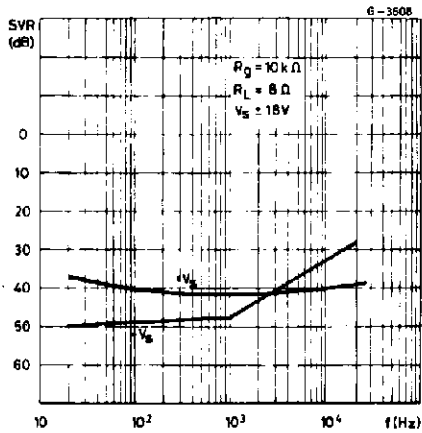


Figure 5: Distorsion vs. output power (f = 1KHz).

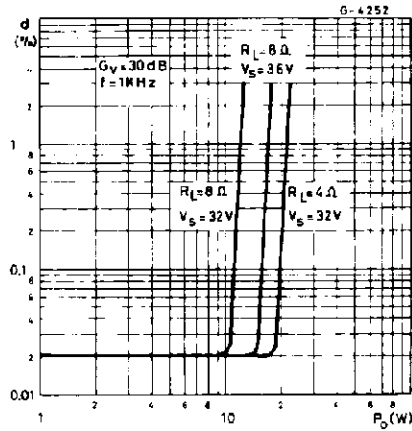


Figure 6. Distorsion vs. output power (f = 1KHz).

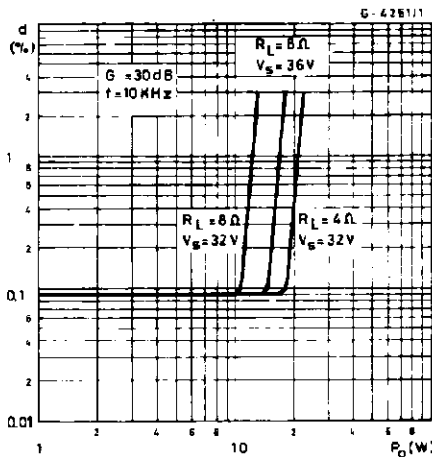
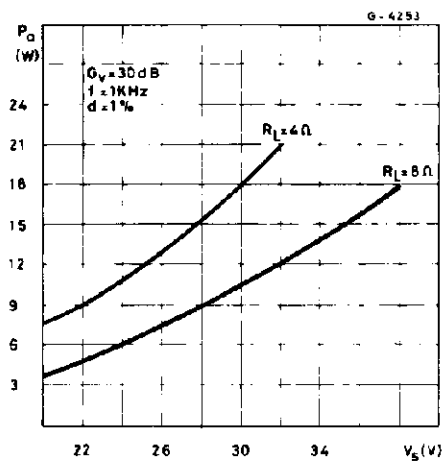
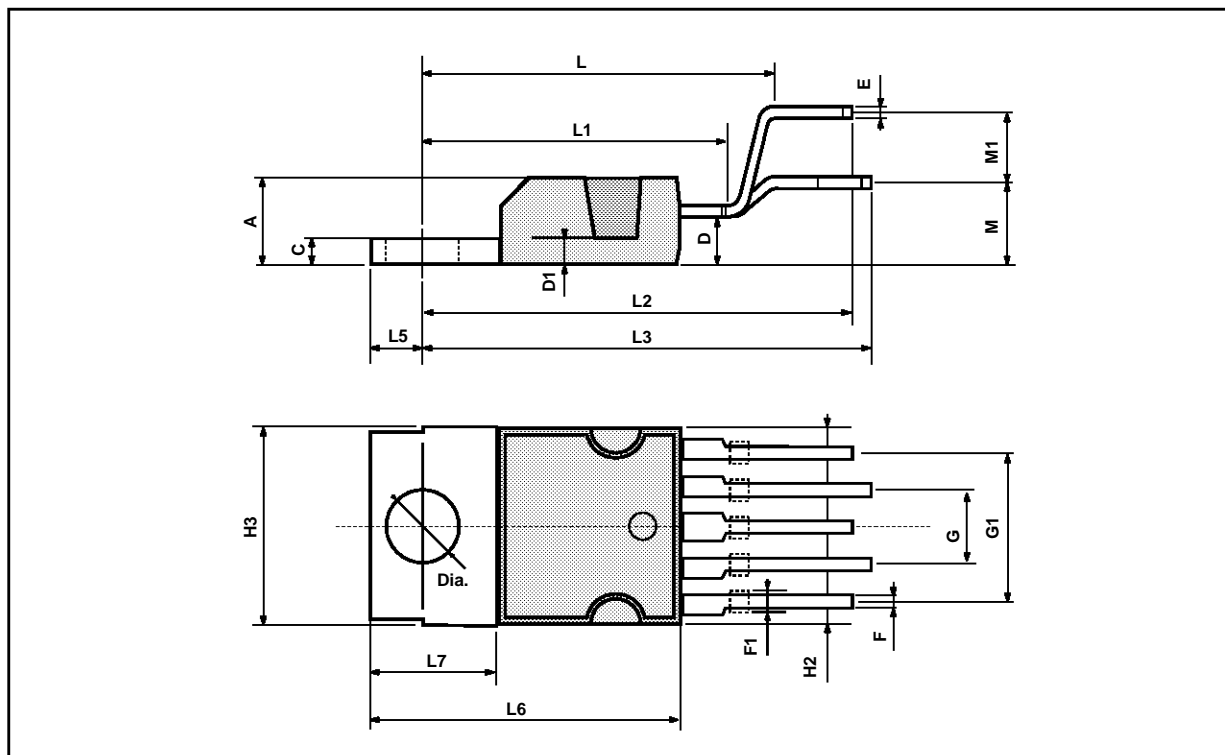


Figure 7. Output power vs. supply voltage.



## PENTAWATT PACKAGE MECHANICAL DATA

DIM.	mm			inch		
	MIN.	TYP.	MAX.	MIN.	TYP.	MAX.
A			4.8			0.189
C			1.37			0.054
D	2.4		2.8	0.094		0.110
D1	1.2		1.35	0.047		0.053
E	0.35		0.55	0.014		0.022
F	0.8		1.05	0.031		0.041
F1	1		1.4	0.039		0.055
G		3.4		0.126	0.134	0.142
G1		6.8		0.260	0.268	0.276
H2			10.4			0.409
H3	10.05		10.4	0.396		0.409
L		17.85			0.703	
L1		15.75			0.620	
L2		21.4			0.843	
L3		22.5			0.886	
L5	2.6		3	0.102		0.118
L6	15.1		15.8	0.594		0.622
L7	6		6.6	0.236		0.260
M		4.5			0.177	
M1		4			0.157	
Dia	3.65		3.85	0.144		0.152



Information furnished is believed to be accurate and reliable. However, SGS-THOMSON Microelectronics assumes no responsibility for the consequences of use of such information nor for any infringement of patents or other rights of third parties which may result from its use. No license is granted by implication or otherwise under any patent or patent rights of SGS-THOMSON Microelectronics. Specifications mentioned in this publication are subject to change without notice. This publication supersedes and replaces all information previously supplied. SGS-THOMSON Microelectronics products are not authorized for use as critical components in life support devices or systems without express written approval of SGS-THOMSON Microelectronics.

© 1994 SGS-THOMSON Microelectronics - All Rights Reserved

SGS-THOMSON Microelectronics GROUP OF COMPANIES

Australia - Brazil - France - Germany - Hong Kong - Italy - Japan - Korea - Malaysia - Malta - Morocco - The Netherlands - Singapore - Spain - Sweden - Switzerland - Taiwan - Thailand - United Kingdom - U.S.A.