



HCF4503

HEX BUFFER

- 1 TTL-LOAD OUTPUT DRIVE CAPABILITY
- 2 OUTPUT-DISABLE CONTROLS
- 3 STATE OUTPUTS
- 5V, 10V, AND 15V PARAMETRIC RATINGS
- QUIESCENT CURRENT SPECIFIED UP TO 15V
- INPUT CURRENT OF 300nA AT 15V AND 25°C
- 100% TESTED FOR QUIESCENT CURRENT MEETS ALL REQUIREMENTS OF JEDEC TENTATIVE STANDARD N⁰. 13A, "STANDARD SPECIFICATIONS FOR DESCRIPTION OF "B" SERIES CMOS DEVICES"

DESCRIPTION

The HCF4503B is a monolithic integrated circuits, available in 16-lead dual in-line plastic package and plastic micro package.

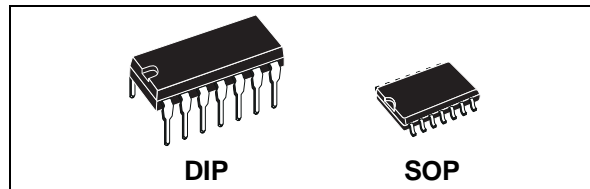

ORDER CODES		
PACKAGE	TUBE	T & R
DIP	HCF4503BEY	
SOP	HCF4503BM1	HCF4503M013TR

The HCF4503B is a hex noninverting buffer with 3-state outputs having high sink and source-current capability. Two disable controls are provided, one of which controls four buffers and the other controls the remaining two buffers.

PIN CONNECTION

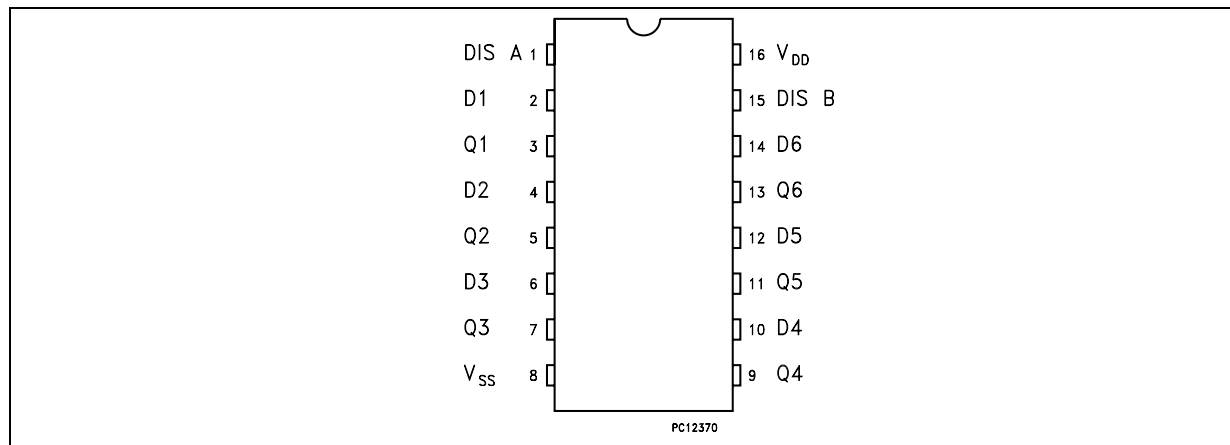

FUNCTIONAL DIAGRAM

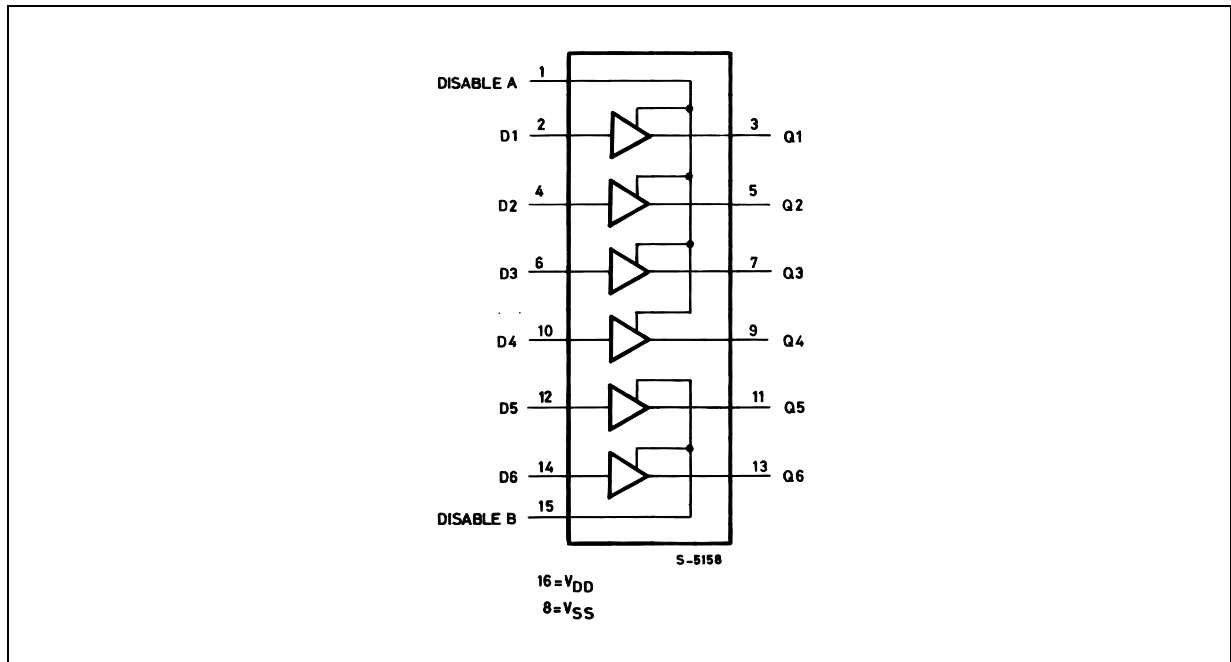

ABSOLUTE MAXIMUM RATING

Symbol	Parameter	Value	Unit
V_{DD}^*	Supply Voltage	-0.5 to +18	V
V_i	Input Voltage	-0.5 to $V_{DD} + 0.5$	V
I_i	DC Input Current (any one input)	± 10	mA
P_{tot}	Total Power Dissipation (per package)	200	mW
	Dissipation per Output Transistor for T_{op} = Full Package Temperature Range	100	mW
T_{op}	Operating Temperature	-40 to +85	$^{\circ}C$
T_{stg}	Storage Temperature	-65 to +150	$^{\circ}C$

Stresses above those listed under "Absolute Maximum Ratings" may cause permanent damage to the device. This is a stress rating only and functional operation of the device at these or any other conditions above those indicated in the operational sections of this specification is not implied. Exposure to absolute maximum rating conditions for external periods may affect device reliability.

* All voltage values are referred to V_{SS} pin voltage.

RECOMMENDED OPERATING CONDITIONS

Symbol	Parameter	Value	Unit
V_{DD}	Supply Voltage	3 to 15	V
V_i	Input Voltage	0 to V_{DD}	V
T_{op}	Operating Temperature	-40 to +85	$^{\circ}C$

LOGIC DIAGRAM AND TRUTH TABLE

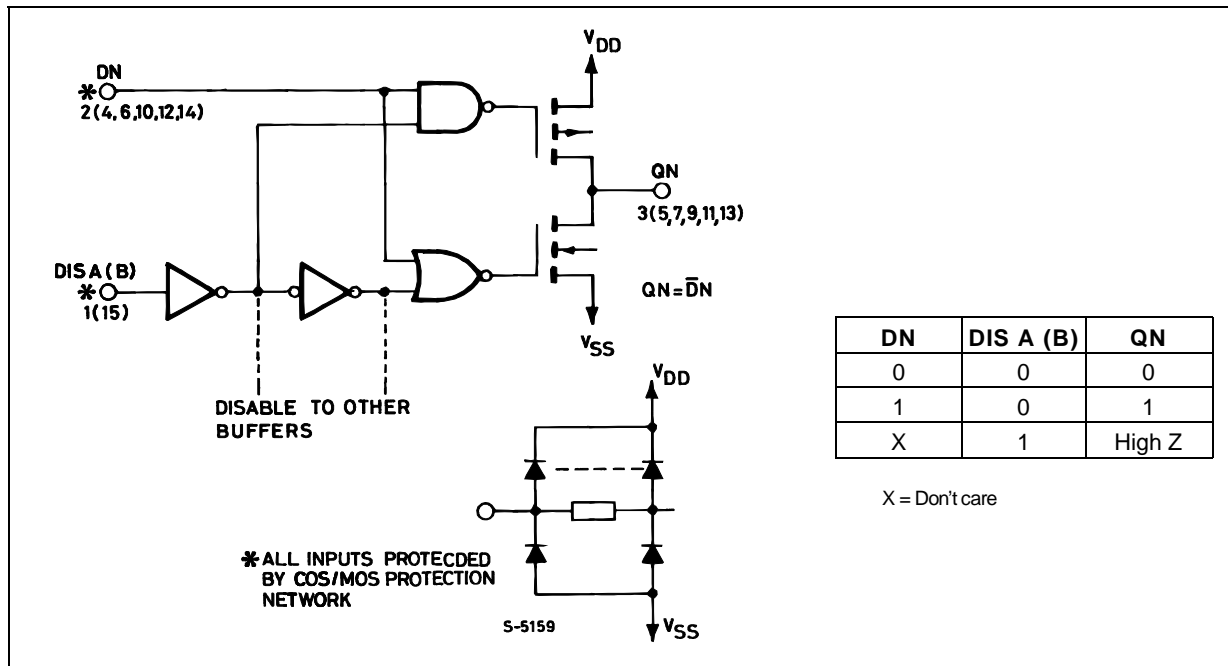

STATIC ELECTRICAL CHARACTERISTICS (over recommended operating conditions)

Symbol	Parameter	Test Conditions				Value						Unit	
		V _I (V)	V _O (V)	I _o (μ A)	V _{DD} (V)	-40 °C		25 °C			85 °C		
						Min.	Max.	Min.	Typ.	Max.	Min.		Max.
I _L	Quiescent Current	0/5			5		4		0.02	4		30	μ A
		0/10			10		8		0.02	8		60	
		0/15			15		16		0.02	16		120	
V _{OH}	Output High Voltage	0/5		< 1	5	4.95		4.95			4.95		V
		0/10		< 1	10	9.95		9.95			9.95		
		0/15		< 1	15	14.95		14.95			14.95		
V _{OL}	Output Low Voltage	5/0		< 1	5		0.05			0.05		0.05	V
		10/0		< 1	10		0.05			0.05		0.05	
		15/0		< 1	15		0.05			0.05		0.05	
V _{IH}	Input High Voltage		0.5/4.5	< 1	5	3.5		3.5			3.5		V
			1/9	< 1	10	7		7			7		
			1.5/13.5	< 1	15	11		11			11		
V _{IL}	Input Low Voltage		4.5/0.5	< 1	5		1.5			1.5		1.5	V
			9/1	< 1	10		3			3		3	
			13.5/1.5	< 1	15		4			4		4	
I _{OH}	Output Drive Current	0/5	2.5		5	-4.8		-4.1	-5.2		-2.9		mA
		0/5	4.6		5	-1		-0.8	-1.6		-0.6		
		0/10	9.5		10	-2.5		-2.2	-3.1		-1.6		
		0/15	13.5		15	-6.8		-5.8	-11.9		-4.2		
I _{OL}	Output Sink Current	0/5	0.4		5	2.1		1.8	1.9		1.2		mA
		0/10	0.5		10	5.4		4.7	5.3		3.3		
		0/15	1.5		15	16		13.7	19.5		9.7		
I _{IH} , I _{IL}	Input Leakage Current	0/15	Any Input		15		± 0.3		$\pm 10^{-5}$	± 0.3		± 1	μ A
I _{OZ}	3-state Output Leakage Current	0/15	Any Input		15		± 1.0		$\pm 10^{-4}$	± 1.0		± 7.5	μ A
C _I	Input Capacitance		Any Input						5	7.5			pF

The Noise Margin for both "1" and "0" level is: 1V min. with V_{DD} = 5 V, 2 V min. with V_{DD} = 10 V, 2.5 V min. with V_{DD} = 15 V

DYNAMIC ELECTRICAL CHARACTERISTICS ($T_{amb} = 25\text{ }^{\circ}\text{C}$, $C_L = 50\text{ pF}$, $R_L = 200\text{ K}\Omega$, typical temperature coefficient for all V_{DD} values is $03\text{ }^{\circ}\text{C}$, all input rise and fall times = 20 ns)

Symbol	Parameter	Test Conditions	Value			Unit	
			V_{DD} (V)	Min.	Typ.		Max.
t_{PLH}	Propagation Delay Time		5		75	150	ns
			10		35	70	
			15		25	50	
t_{PHL}	Propagation Delay Time		5		55	110	ns
			10		25	50	
			15		17	35	
t_{PHZ} t_{PZH}	3-State Propagation Delay Time		5		70	140	ns
			10		30	60	
			15		25	50	
t_{PZL} t_{PLZ}	3-State Propagation Delay Time		5		90	180	ns
			10		40	80	
			15		35	70	
t_{TLH}	Transition Time		5		50	90	ns
			10		30	45	
			15		25	35	
t_{THL}	Transition Time		5		35	70	ns
			10		20	40	
			15		13	25	

N-Channel Output Low (sink) Current Characteristics.

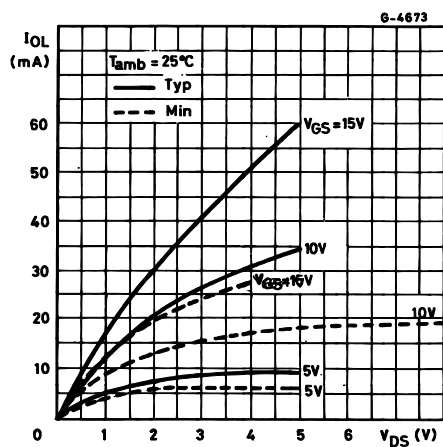

P-Channel Output High (source) Current Characteristics.

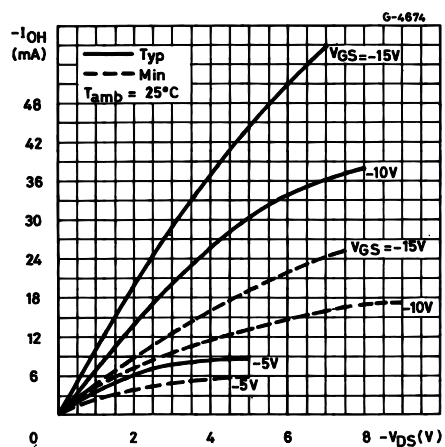

Typical Propagation Delay Time vs. Load Capacitance.

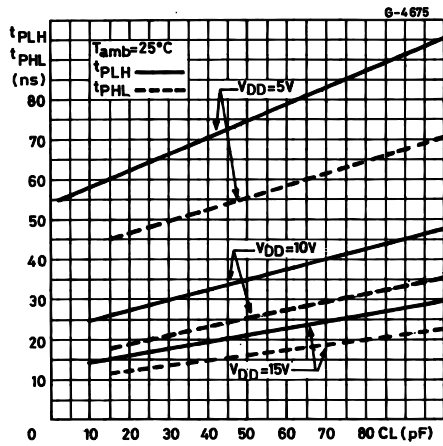

Typical Transition Time vs. Load Capacitance.

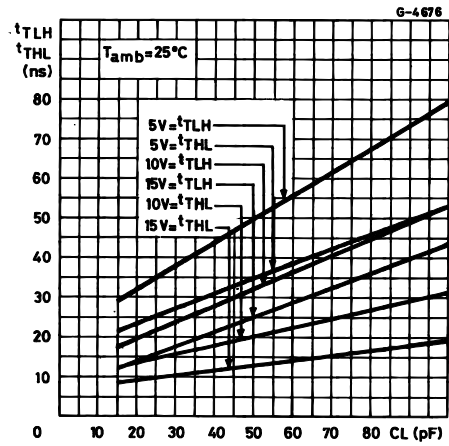

Typical Dynamic Power Dissipation vs.

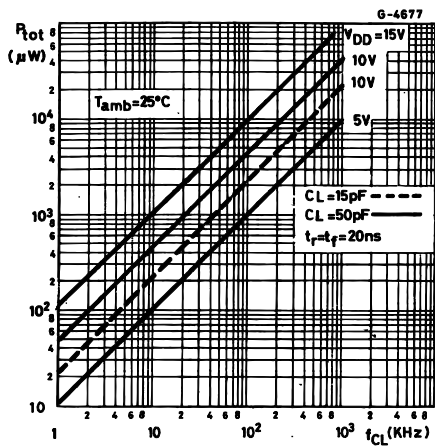

TEST CIRCUITS

Quiescent Device Current.

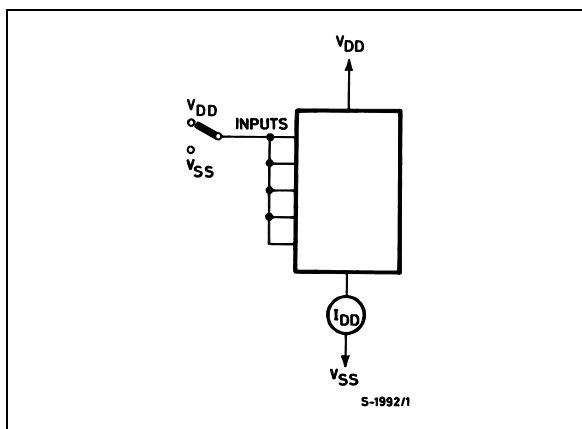

Input Voltage.

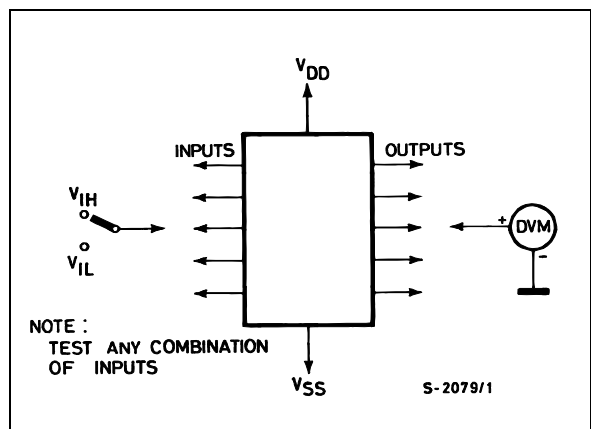

TEST CIRCUIT (continued)

Input Leakage Current.

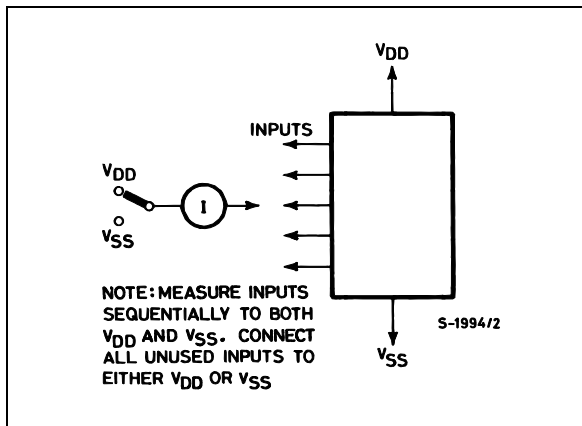

Dynamic Power Dissipation.

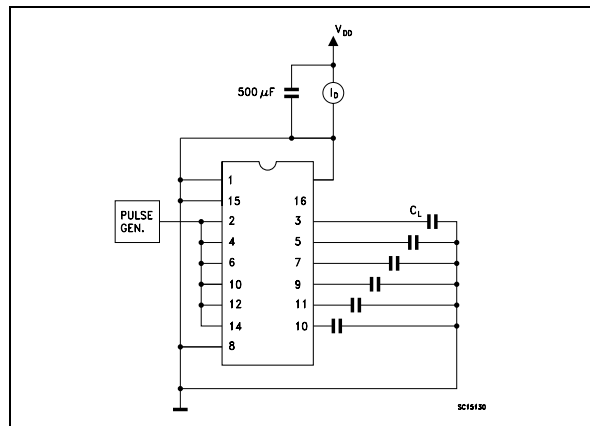

Plastic DIP-14 MECHANICAL DATA

DIM.	mm			inch		
	MIN.	TYP.	MAX.	MIN.	TYP.	MAX.
a1	0.51			0.020		
B	1.39		1.65	0.055		0.065
b		0.5			0.020	
b1		0.25			0.010	
D			20			0.787
E		8.5			0.335	
e		2.54			0.100	
e3		15.24			0.600	
F			7.1			0.280
I			5.1			0.201
L		3.3			0.130	
Z	1.27		2.54	0.050		0.100

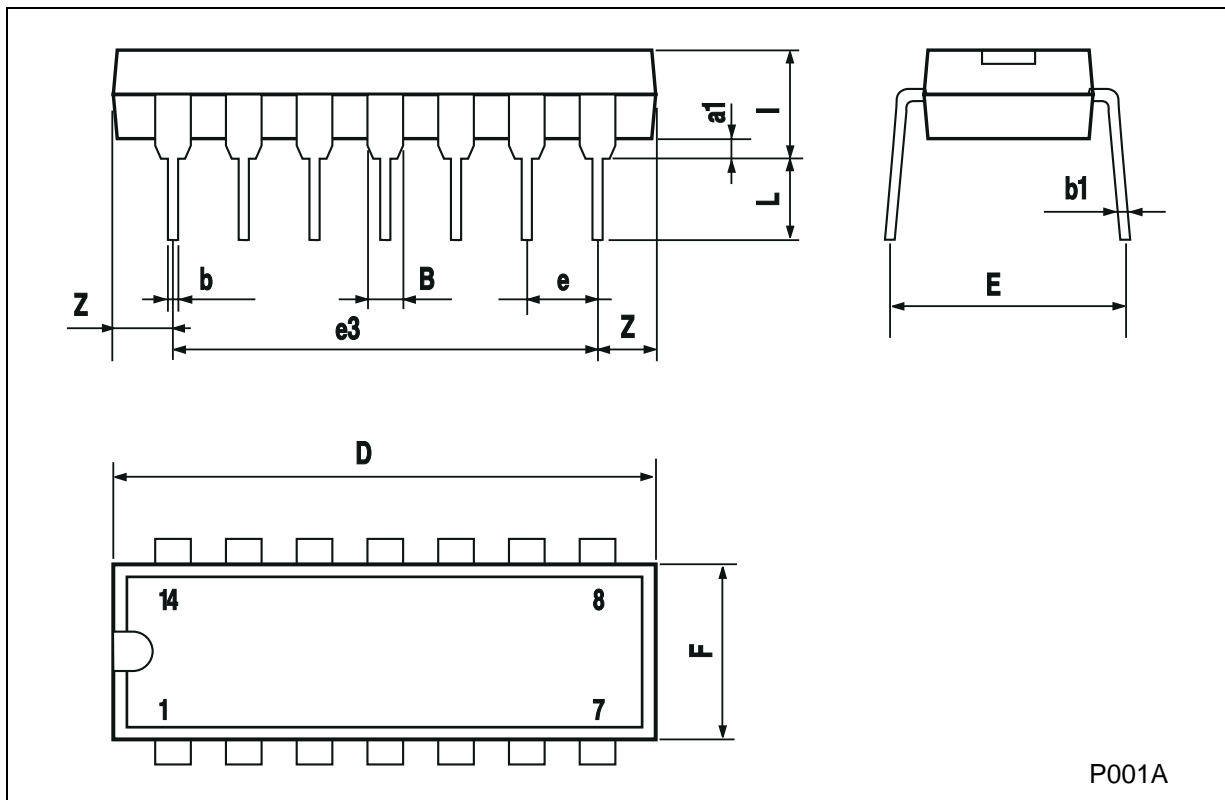

P001A

SO-14 MECHANICAL DATA

DIM.	mm			inch		
	MIN.	TYP.	MAX.	MIN.	TYP.	MAX.
A			1.75			0.068
a1	0.1		0.2	0.003		0.007
a2			1.65			0.064
b	0.35		0.46	0.013		0.018
b1	0.19		0.25	0.007		0.010
C		0.5			0.019	
c1	45 (typ.)					
D	8.55		8.75	0.336		0.344
E	5.8		6.2	0.228		0.244
e		1.27			0.050	
e3		7.62			0.300	
F	3.8		4.0	0.149		0.157
G	4.6		5.3	0.181		0.208
L	0.5		1.27	0.019		0.050
M			0.68			0.026
S	8 (max.)					

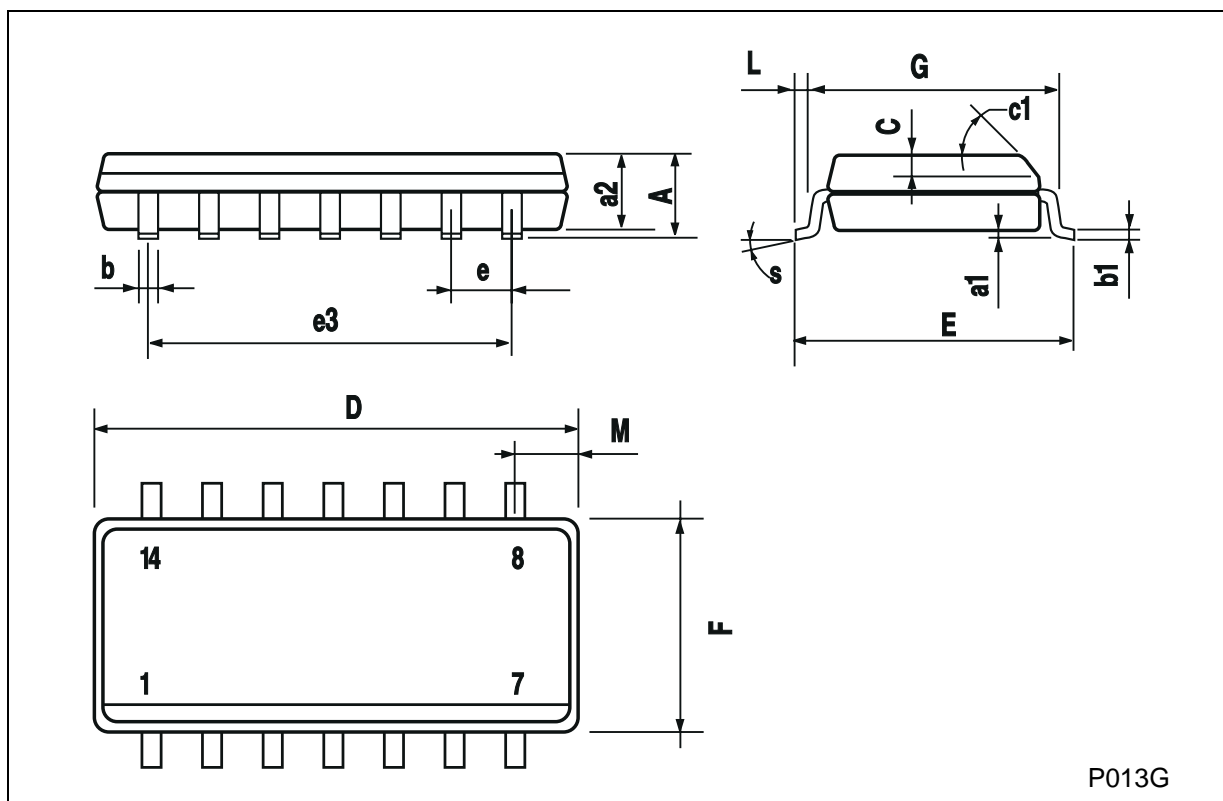

Information furnished is believed to be accurate and reliable. However, STMicroelectronics assumes no responsibility for the consequences of use of such information nor for any infringement of patents or other rights of third parties which may result from its use. No license is granted by implication or otherwise under any patent or patent rights of STMicroelectronics. Specification mentioned in this publication are subject to change without notice. This publication supersedes and replaces all information previously supplied. STMicroelectronics products are not authorized for use as critical components in life support devices or systems without express written approval of STMicroelectronics.

The ST logo is a registered trademark of STMicroelectronics

© 2000 STMicroelectronics – Printed in Italy – All Rights Reserved

STMicroelectronics GROUP OF COMPANIES

Australia - Brazil - China - Finland - France - Germany - Hong Kong - India - Italy - Japan - Malaysia - Malta - Morocco
Singapore - Spain - Sweden - Switzerland - United Kingdom - U.S.A.

<http://www.st.com>



LittleDiode supplies new, hard to find or obsolete electronic components and semiconductors all over the world.

With over two million different components listed you are sure to find the part you need.

Feel free to visit us today at our online store:

LittleDiode.com

Looking forward to providing you with the best possible service.