

0.4 Amp Output Current IGBT Gate Drive Optocoupler

Technical Data

Features

- **0.4 A Minimum Peak Output Current**
- **High Speed Response: 0.7 μ s Max. Propagation Delay over Temp. Range**
- **Ultra High CMR: Min. 10 kV/ μ s at $V_{CM} = 1.5$ kV**
- **Bootstrappable Supply Current: Max. 3 mA**
- **Wide Operating Temp. Range: -40°C to 100°C**
- **Wide V_{CC} Operating Range: 10 V to 30 V over Temp. Range**
- **Available in DIP8 (Single) and SO16 (Dual) Package**
- **Safety Approvals: UL Recognized, 3750 V_{rms} for 1 Minute. CSA Approval. IEC/EN/DIN EN 60747-5-2 Approval VIORM=891 V_{peak}**

Description

The HCPL-314J family of devices consists of an AlGaAs LED optically coupled to an integrated circuit with a power output stage. These optocouplers are ideally suited for driving power IGBTs and MOSFETs used in motor control inverter applications. The high operating voltage range of the output stage provides the drive voltages required by gate controlled devices. The voltage and current supplied by this optocoupler makes it ideally suited for directly driving small or medium power IGBTs. For IGBTs with higher ratings the HCPL-3150(0.5A) or HCPL-3120 (2.0A) optocouplers can be used.

Applications

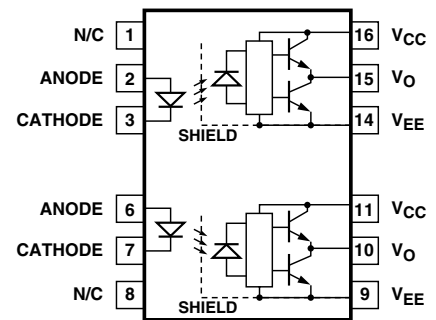
- **Isolated IGBT/Power MOSFET Gate Drive**
- **AC and Brushless DC Motor Drives**
- **Inverters for Appliances**
- **Industrial Inverters**
- **Switch Mode Power Supplies (SMPS)**
- **Uninterruptable Power Supplies (UPS)**

A 0.1 μ F bypass capacitor must be connected between pins V_{CC} and V_{EE} .

CAUTION: It is advised that normal static precautions be taken in handling and assembly of this component to prevent damage and/or degradation which may be induced by ESD.

HCPL-314J

Functional Diagram



HCPL-314J

Truth Table

LED	V_o
OFF	LOW
ON	HIGH

Selection Guide

Package Type	Part Number	Number of Channels
SO16	HCPL-314J	2

Ordering Information

Specify part number followed by option number (if desired)

Example:

HCPL-314J#YYYY

No option = SO16 Package.

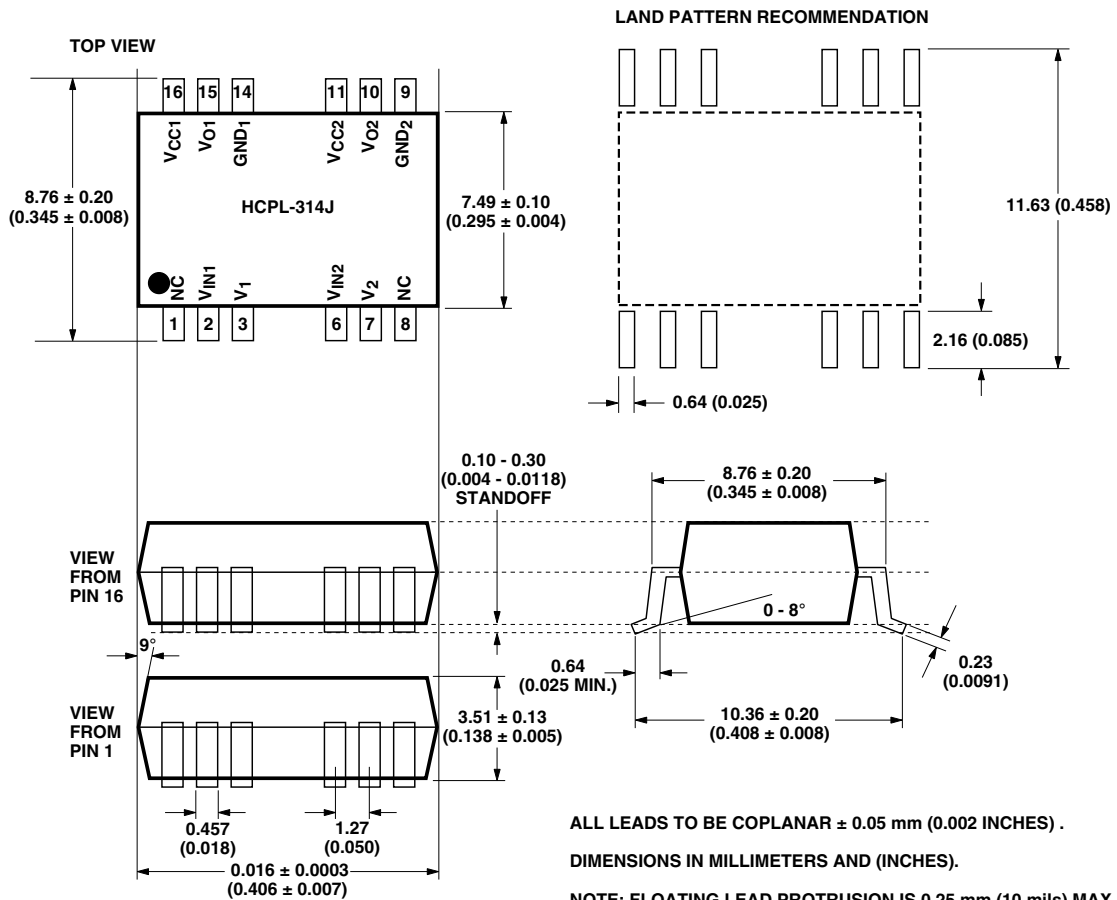
500 = Tape and Reel Packaging Option.

XXXE = Lead Free Option

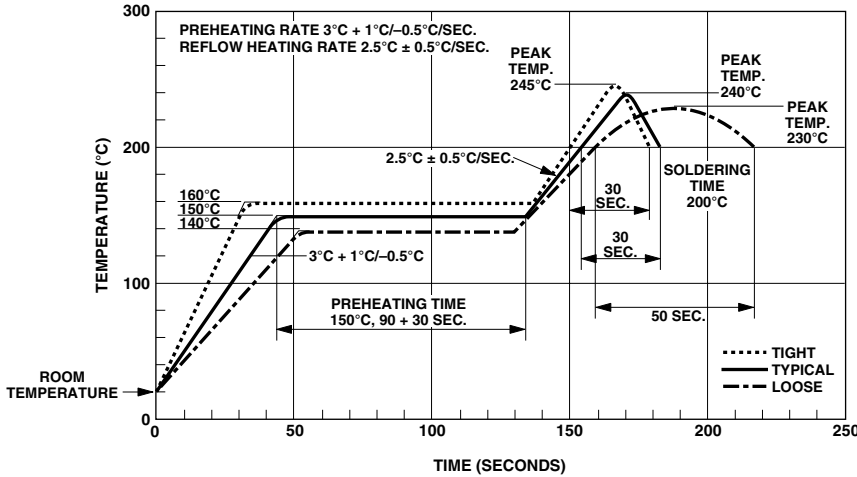
Remarks: The notation “#” is used for existing products, while (new) products launched since 15th July 2001 and lead free option will use “-”

Package Outline Drawing

HCPL-314J SO16 Package:



Solder Reflow Thermal Profile



Regulatory Information

The HCPL-314J has been approved by the following organizations:

IEC/EN/DIN EN 60747-5-2

Approved under:
 IEC 60747-5-2:1997 + A1:2002
 EN 60747-5-2:2001 + A1:2002
 DIN EN 60747-5-2 (VDE 0884 Teil 2):2003-01.

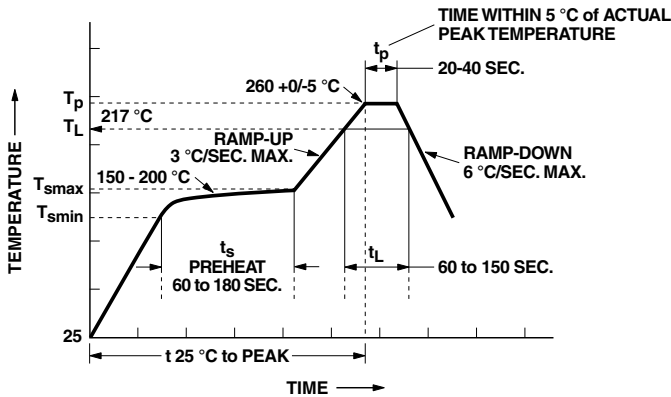
UL

Approval under UL 1577, component recognition program up to $V_{\text{ISO}} = 3750 V_{\text{rms}}$. File E55361.

CSA

Approved under CSA Component Acceptance Notice #5, File CA 88324.

Recommended Pb-Free IR Profile



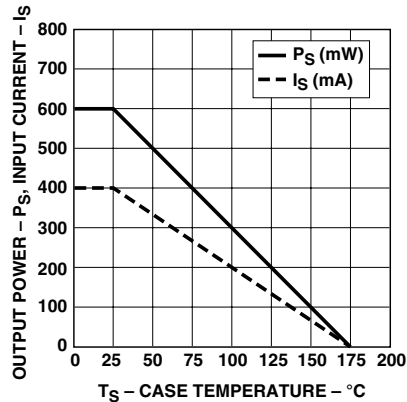
NOTES:
 THE TIME FROM 25°C to PEAK TEMPERATURE = 8 MINUTES MAX.
 $T_{smax} = 200^{\circ}\text{C}$, $T_{smin} = 150^{\circ}\text{C}$

IEC/EN/DIN EN 60747-5-2 Insulation Characteristics

Description	Symbol	Characteristic	Unit
Installation classification per DIN VDE 0110/1.89, Table 1 for rated mains voltage $\leq 150 V_{rms}$ for rated mains voltage $\leq 300 V_{rms}$ for rated mains voltage $\leq 600 V_{rms}$		I - IV I - III I-II	
Climatic Classification		55/100/21	
Pollution Degree (DIN VDE 0110/1.89)		2	
Maximum Working Insulation Voltage	V_{IORM}	891	V_{peak}
Input to Output Test Voltage, Method b* $V_{IORM} \times 1.875 = V_{PR}$, 100% Production Test with $t_m = 1$ sec, Partial discharge < 5 pC	V_{PR}	1670	V_{peak}
Input to Output Test Voltage, Method a* $V_{IORM} \times 1.5 = V_{PR}$, Type and Sample Test, $t_m = 60$ sec, Partial discharge < 5 pC	V_{PR}	1336	V_{peak}
Highest Allowable Overvoltage (Transient Overvoltage $t_{ini} = 10$ sec)	V_{IOTM}	6000	V_{peak}
Safety-limiting values - maximum values allowed in the event of a failure. Case Temperature Input Current** Output Power**	T_S $I_{S,INPUT}$ $P_{S, OUTPUT}$	175 400 1200	$^{\circ}C$ mA mW
Insulation Resistance at $T_S, V_{IO} = 500$ V	R_S	$> 10^9$	Ω

* Refer to the optocoupler section of the Isolation and Control Components Designer's Catalog, under Product Safety Regulations section, IEC/EN/DIN EN 60747-5-2, for a detailed description of Method a and Method b partial discharge test profiles.

** Refer to the following figure for dependence of P_S and I_S on ambient temperature.



Insulation and Safety Related Specifications

Parameter	Symbol	HCPL-314J	Units	Conditions
Minimum External Air Gap (Clearance)	L(101)	8.3	mm	Measured from input terminals to output terminals, shortest distance through air.
Minimum External Tracking (Creepage)	L(102)	8.3	mm	Measured from input terminals to output terminals, shortest distance path along body.
Minimum Internal Plastic Gap (Internal Clearance)		0.5	mm	Through insulation distance conductor to conductor, usually the straight line distance thickness between the emitter and detector.
Tracking Resistance (Comparative Tracking Index)	CTI	>175	V	DIN IEC 112/VDE 0303 Part 1
Isolation Group		IIIa		Material Group (DIN VDE 0110, 1/89, Table 1)

Absolute Maximum Ratings

Parameter	Symbol	Min.	Max.	Units	Note
Storage Temperature	T_S	-55	125	°C	
Operating Temperature	T_A	-40	100	°C	
Average Input Current	$I_{F(AVG)}$		25	mA	1
Peak Transient Input Current (<1 μ s pulse width, 300pps)	$I_{F(TRAN)}$		1.0	A	
Reverse Input Voltage	V_R		3	V	
“High” Peak Output Current	$I_{OH(PEAK)}$		0.6	A	2
“Low” Peak Output Current	$I_{OL(PEAK)}$		0.6	A	2
Supply Voltage	$V_{CC-V_{EE}}$	-0.5	35	V	
Output Voltage	$V_{O(PEAK)}$	-0.5	V_{CC}	V	
Output Power Dissipation	P_O		260	mW	3
Input Power Dissipation	P_I		105	mW	4
Lead Solder Temperature	260°C for 10 sec., 1.6 mm below seating plane				
Solder Reflow Temperature Profile	See Package Outline Drawings section				

Recommended Operating Conditions

Parameter	Symbol	Min.	Max.	Units	Note
Power Supply	$V_{CC-V_{EE}}$	10	30	V	
Input Current (ON)	$I_{F(ON)}$	8	12	mA	
Input Voltage (OFF)	$V_{F(OFF)}$	-3.0	0.8	V	
Operating Temperature	T_A	-40	100	°C	

Electrical Specifications (DC)

Over recommended operating conditions unless otherwise specified.

Parameter	Symbol	Min.	Typ.	Max.	Units	Test Conditions	Fig.	Note
High Level Output Current	I _{OH}	0.2			A	V _o = V _{CC} -4	2	5
		0.4	0.5			V _o = V _{CC} -10	3	2
Low Level Output Current	I _{OL}	0.2	0.4		A	V _o = V _{EE} +2.5	5	5
		0.4	0.5			V _o = V _{EE} +10	6	2
High Level Output Voltage	V _{OH}	V _{CC} -4	V _{CC} -1.8		V	I _o = -100 mA	1	6,7
Low Level Output Voltage	V _{OL}		0.4	1	V	I _o = 100 mA	4	
High Level Supply Current	I _{CCH}		0.7	3	mA	I _o = 0 mA	7,8	15
Low Level Supply Current	I _{CCL}		1.2	3	mA	I _o = 0 mA		
Threshold Input Current Low to High	I _{FLH}			5	mA	I _o = 0 mA, V _o > 5 V	9,15	
Threshold Input Voltage High to Low	V _{FHL}	0.8			V			
Input Forward Voltage	V _F	1.2	1.5	1.8	V	I _F = 10 mA	16	
Temperature Coefficient of Input Forward Voltage	ΔV _F /ΔT _A		-1.2		mV/°C			
Input Reverse Breakdown Voltage	BV _R	3	10		V	I _R = 100 μA		
Input Capacitance	C _{IN}				pF	f = 1 MHz, V _F = 0 V		

Switching Specifications (AC)

Over recommended operating conditions unless otherwise specified.

Parameter	Symbol	Min.	Typ.	Max.	Units	Test Conditions	Fig.	Note
Propagation Delay Time to High Output Level	t _{PLH}	0.1	0.2	0.7	μs	R _g = 47 Ω, C _g = 3 nF, f = 10 kHz, Duty Cycle = 50%, I _F = 8 mA, V _{CC} = 30 V	10,11, 12,13, 14,17	14
Propagation Delay Time to Low Output Level	t _{PHL}	0.1	0.3	0.7	μs			
Propagation Delay Difference Between Any Two Parts or Channels	PDD	-0.5		0.5	μs			10
Rise Time	t _R				ns			
Fall Time	t _F				ns			
Output High Level Common Mode Transient Immunity	CM _H	10	30		kV/μs	T _A = 25°C, V _{CM} = 1.5 kV	18	11, 12
Output Low Level Common Mode Transient Immunity	CM _L	10	30		kV/μs			18

Package Characteristics

For each channel unless otherwise specified.

Parameter	Symbol	Min.	Typ.	Max.	Units	Test Conditions	Fig.	Note
Input-Output Momentary Withstand Voltage	V_{ISO}	3750			V_{rms}	$T_A=25^{\circ}C$, $RH<50\%$ for 1 min.		8,9
Output-Output Momentary Withstand Voltage	V_{O-O}	1500			V_{rms}			16
Input-Output Resistance	R_{I-O}		10^{12}		Ω	$V_{I-O}=500\text{ V}$		9
Input-Output Capacitance	C_{I-O}		1.2		pF	Freq=1 MHz		

Notes:

- Derate linearly above 70°C free air temperature at a rate of 0.3 mA/°C.
- Maximum pulse width = 10 μ s, maximum duty cycle = 0.2%. This value is intended to allow for component tolerances for designs with I_O peak minimum = 0.4 A. See Application section for additional details on limiting I_{OL} peak.
- Derate linearly above 85°C, free air temperature at the rate of 4.0 mW/°C.
- Input power dissipation does not require derating.
- Maximum pulse width = 50 μ s, maximum duty cycle = 0.5%.
- In this test, V_{OH} is measured with a DC load current. When driving capacitive load V_{OH} will approach V_{CC} as I_{OH} approaches zero amps.
- Maximum pulse width = 1 ms, maximum duty cycle = 20%.
- In accordance with UL 1577, each HCPL-314J optocoupler is proof tested by applying an insulation test voltage $\geq 5000 V_{rms}$ for 1 second (leakage detection current limit $I_{L-O} \leq 5 \mu A$). This test is performed before 100% production test for partial discharge (method B) shown in the IEC/EN/DIN EN 60747-5-2 Insulation Characteristics Table, if applicable.
- Device considered a two-terminal device: pins on input side shorted together and pins on output side shorted together.
- PDD is the difference between t_{PHL} and t_{PLH} between any two parts or channels under the same test conditions.
- Pins 3 and 4 (HCPL-314J) need to be connected to LED common.
- Common mode transient immunity in the high state is the maximum tolerable $|dV_{CM}/dt|$ of the common mode pulse V_{CM} to assure that the output will remain in the high state (i.e. $V_o > 6.0\text{ V}$).
- Common mode transient immunity in a low state is the maximum tolerable $|dV_{CM}/dt|$ of the common mode pulse, V_{CM} , to assure that the output will remain in a low state (i.e. $V_o < 1.0\text{ V}$).
- This load condition approximates the gate load of a 1200 V/25 A IGBT.
- For each channel. The power supply current increases when operating frequency and Q_g of the driven IGBT increases.
- Device considered a two terminal device: Channel one output side pins shorted together, and channel two output side pins shorted together.

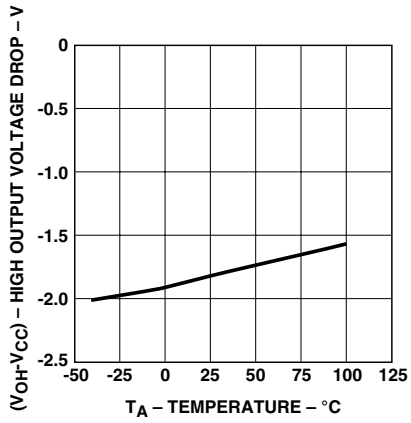


Figure 1. V_{OH} vs. Temperature.

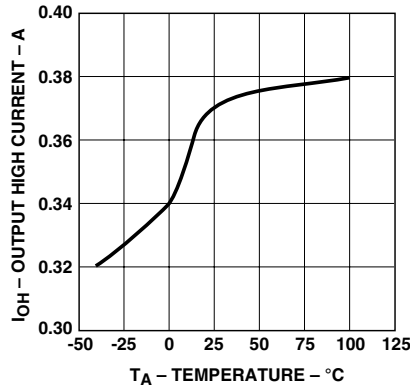


Figure 2. I_{OH} vs. Temperature.

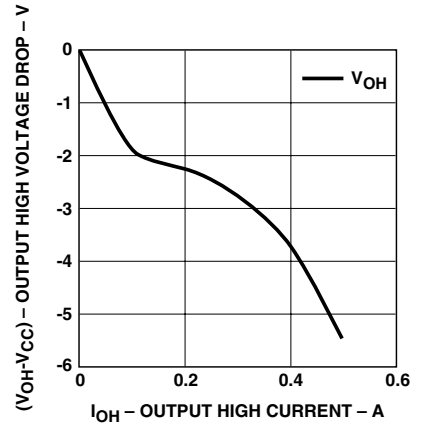


Figure 3. V_{OH} vs. I_{OH} .

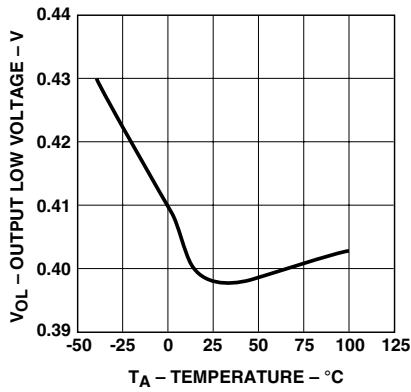


Figure 4. V_{OL} vs. Temperature.

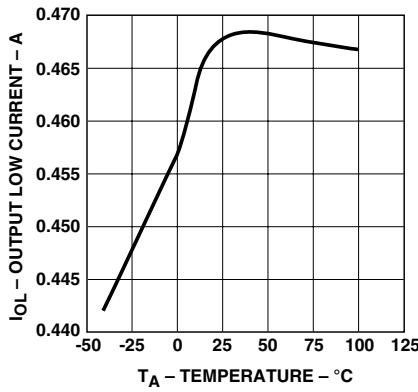


Figure 5. I_{OL} vs. Temperature.

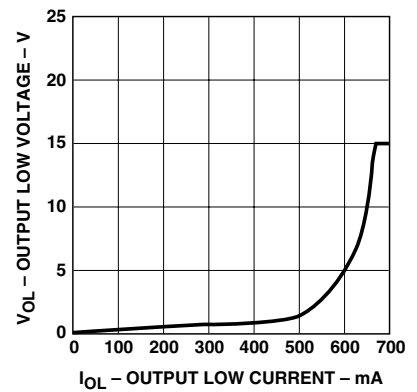


Figure 6. V_{OL} vs. I_{OL} .

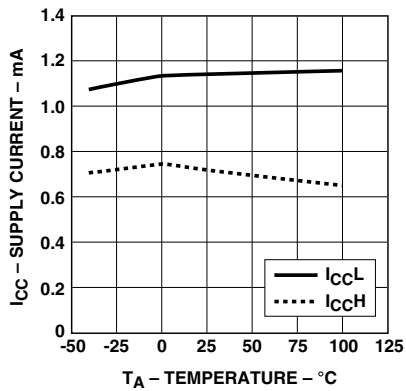


Figure 7. I_{CC} vs. Temperature.

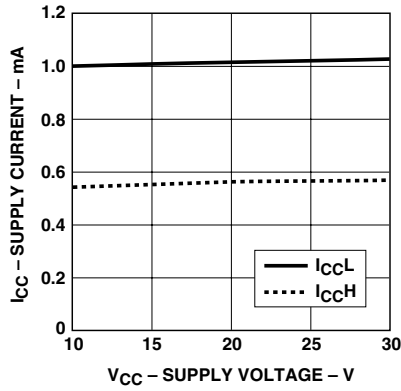


Figure 8. I_{CC} vs. V_{CC} .

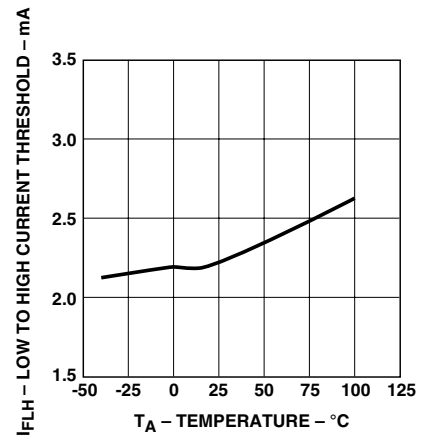


Figure 9. I_{FLH} vs. Temperature.

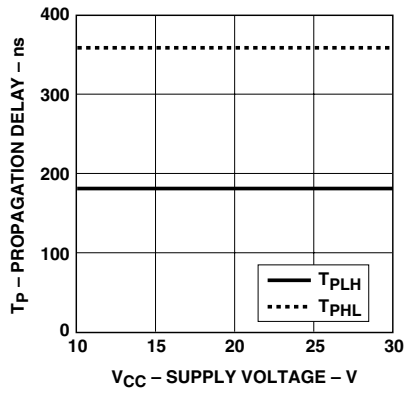
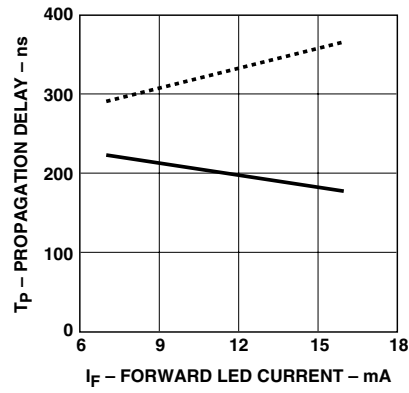
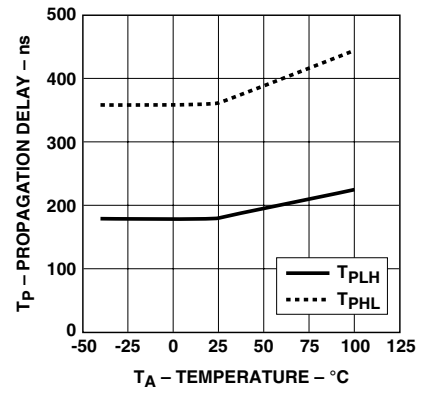
Figure 10. Propagation Delay vs. V_{CC} .Figure 11. Propagation Delay vs. I_F .

Figure 12. Propagation Delay vs. Temperature.

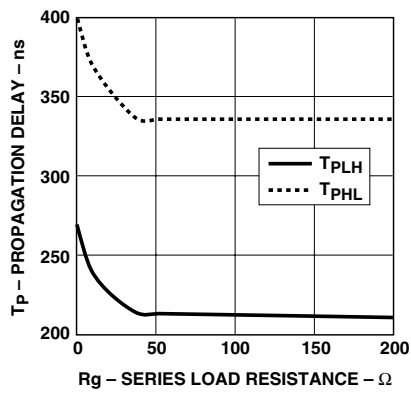
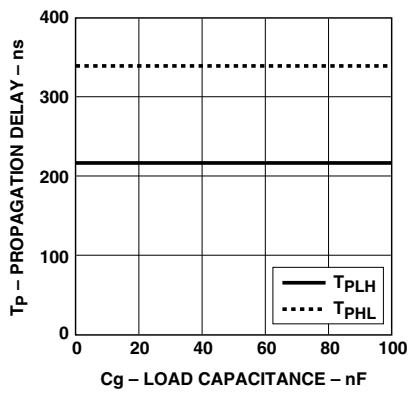
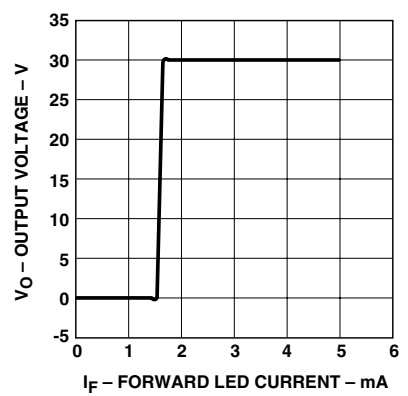
Figure 13. Propagation Delay vs. R_g .Figure 14. Propagation Delay vs. C_g .

Figure 15. Transfer Characteristics.

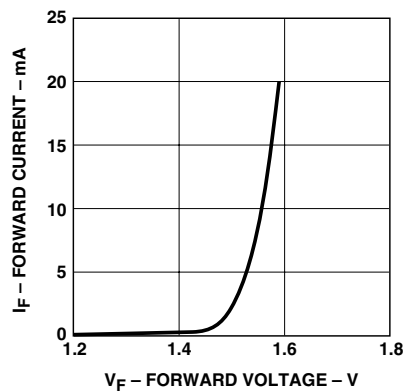


Figure 16. Input Current vs. Forward Voltage.

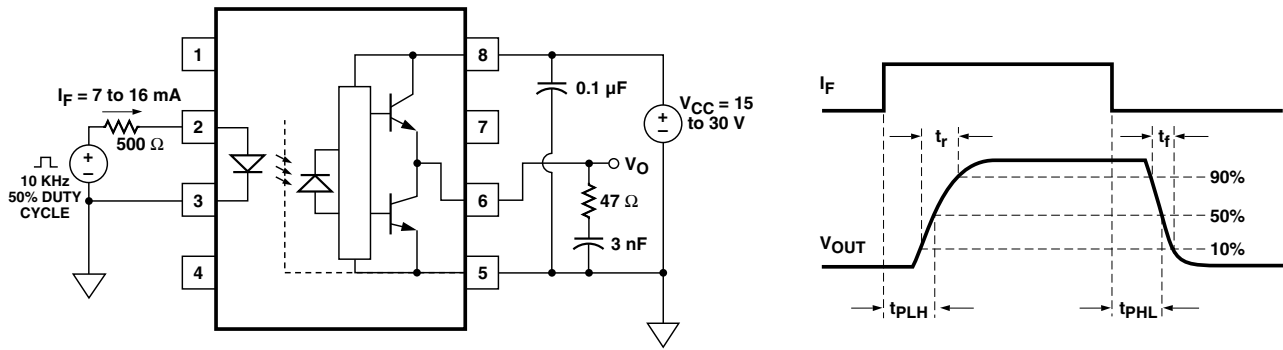


Figure 17. Propagation Delay Test Circuit and Waveforms.

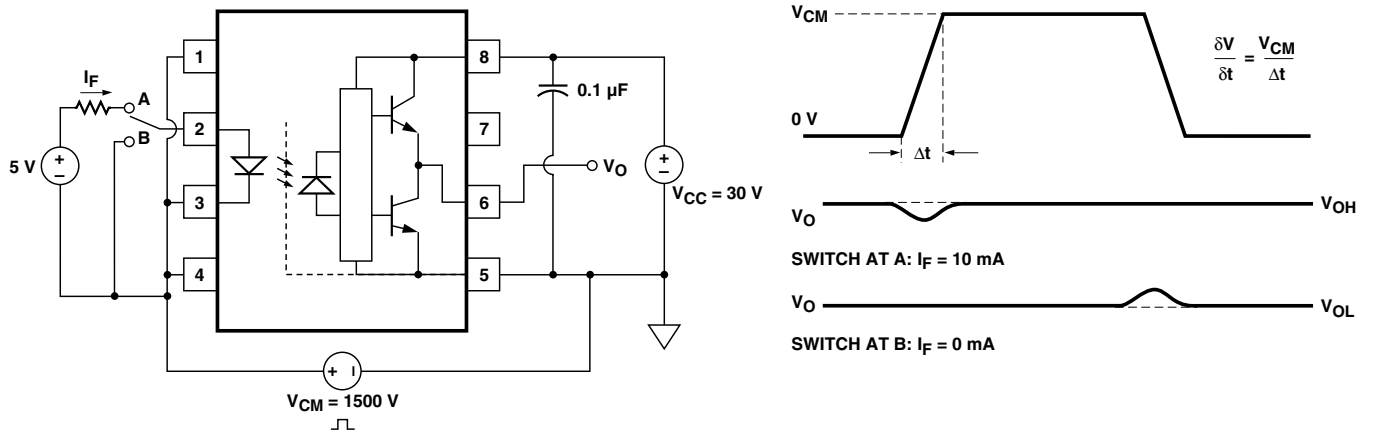


Figure 18. CMR Test Circuit and Waveforms.

Selecting the Gate Resistor (R_g)

Step 1: Calculate R_g minimum from the I_{OL} peak specification. The IGBT and R_g in Figure 24 can be analyzed as a simple RC circuit with a voltage supplied by the HCPL-314J.

$$\begin{aligned} R_g &\geq \frac{V_{CC} - V_{OL}}{I_{OLPEAK}} \\ &= \frac{24\text{ V} - 5\text{ V}}{0.6\text{ A}} \\ &= 32\ \Omega \end{aligned}$$

The V_{OL} value of 5 V in the previous equation is the V_{OL} at the peak current of 0.6A. (See Figure 6).

Step 2: Check the HCPL-314J power dissipation and increase R_g if necessary. The HCPL-314J total power dissipation (P_T) is equal to the sum of the emitter power (P_E) and the output power (P_O).

$$P_T = P_E + P_O$$

$$P_E = I_F \cdot V_F \cdot \text{Duty Cycle}$$

$$\begin{aligned} P_O &= P_{O(BIAS)} + P_{O(SWITCHING)} = I_{CC} \cdot V_{CC} + E_{SW} (R_g, Q_g) \cdot f \\ &= (I_{CCBIAS} + K_{ICC} \cdot Q_g \cdot f) \cdot V_{CC} + E_{SW} (R_g, Q_g) \cdot f \end{aligned}$$

where $K_{ICC} \cdot Q_g \cdot f$ is the increase in I_{CC} due to switching and K_{ICC} is a constant of 0.001 mA/(nC*kHz). For the circuit in Figure 19 with I_F (worst case) = 10 mA, R_g = 32 Ω, Max Duty Cycle = 80%, Q_g = 100 nC, f = 20 kHz and T_{AMAX} = 85°C:

$$P_E = 10\text{ mA} \cdot 1.8\text{ V} \cdot 0.8 = 14\text{ mW}$$

$$P_O = (3\text{ mA} + (0.001\text{ mA}/(\text{nC} \cdot \text{kHz})) \cdot 20\text{ kHz} \cdot 100\text{ nC}) \cdot 24\text{ V} + 0.4\ \mu\text{J} \cdot 20\text{ kHz} = 128\text{ mW}$$

$$< 260\text{ mW } (P_{O(MAX)} \text{ @ } 85^\circ\text{C})$$

The value of 3 mA for I_{CC} in the previous equation is the max. I_{CC} over entire operating temperature range.

Since P_O for this case is less than P_{O(MAX)}, R_g = 32 Ω is alright for the power dissipation.

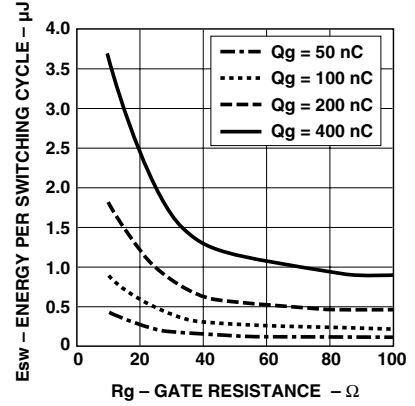


Figure 20. Energy Dissipated in the HCPL-314J and for Each IGBT Switching Cycle.

LED Drive Circuit Considerations for Ultra High CMR Performance

Without a detector shield, the dominant cause of optocoupler CMR failure is capacitive coupling from the input side of the optocoupler, through the package, to the detector IC as shown in Figure 21. The HCPL-314J improves CMR performance by using a detector IC with an optically transparent Faraday shield, which diverts the capacitively coupled current away from the sensitive IC circuitry. However, this shield does not eliminate the capacitive coupling between the LED and optocoupler pins 5-8 as shown in Figure 22. This capacitive coupling causes perturbations in the LED current during common mode transients and becomes the major source of CMR failures for a shielded optocoupler. The main design objective of a high CMR LED drive circuit becomes keeping the LED in the proper state (on or off) during common mode transients. For example, the recommended application circuit (Figure 19), can achieve 10 kV/μs CMR while minimizing component complexity.

Techniques to keep the LED in the proper state are discussed in the next two sections.

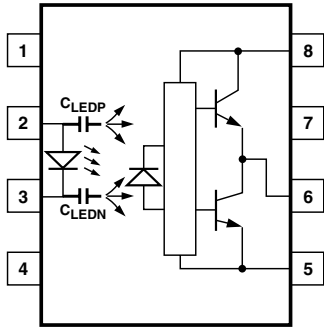


Figure 21. Optocoupler Input to Output Capacitance Model for Unshielded Optocouplers.

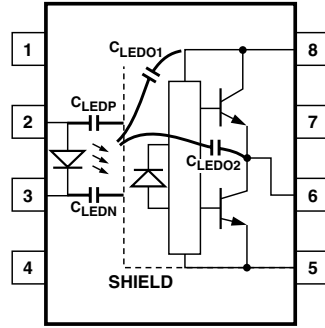


Figure 22. Optocoupler Input to Output Capacitance Model for Shielded Optocouplers.

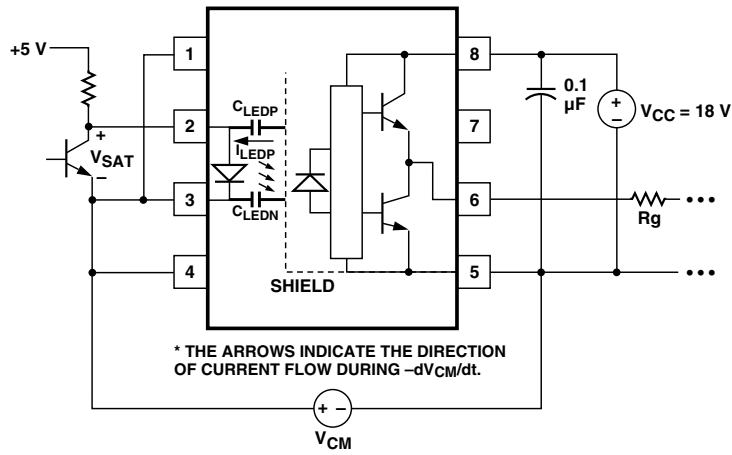


Figure 23. Equivalent Circuit for Figure 17 During Common Mode Transient.

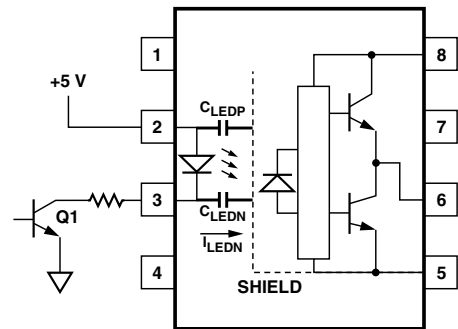


Figure 24. Not Recommended Open Collector Drive Circuit.

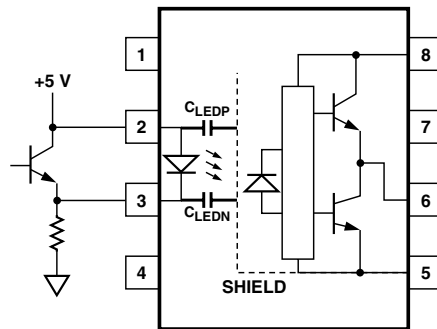


Figure 25. Recommended LED Drive Circuit for Ultra-High CMR IPM Dead Time and Propagation Delay Specifications.

CMR with the LED On (CMR_H)

A high CMR LED drive circuit must keep the LED on during common mode transients. This is achieved by overdriving the LED current beyond the input threshold so that it is not pulled below the threshold during a transient. A minimum LED current of 8 mA provides adequate margin over the maximum I_{FLH} of 5 mA to achieve 10 kV/ μ s CMR.

CMR with the LED Off (CMR_L)

A high CMR LED drive circuit must keep the LED off ($V_F \leq V_{F(OFF)}$) during common mode transients. For example, during a $-dV_{CM}/dt$ transient in Figure 23, the current flowing through C_{LEDP} also flows through the R_{SAT} and V_{SAT} of the logic gate. As long as the low state voltage developed across the logic gate is less than $V_{F(OFF)}$ the LED will remain off and no common mode failure will occur.

The open collector drive circuit, shown in Figure 24, can not keep the LED off during a $+dV_{CM}/dt$ transient, since all the current flowing through C_{LEDN} must be

supplied by the LED, and it is not recommended for applications requiring ultra high CMR₁ performance. The alternative drive circuit which like the recommended application circuit (Figure 19), does achieve ultra high CMR performance by shunting the LED in the off state.

IPM Dead Time and Propagation Delay Specifications

The HCPL-314J includes a Propagation Delay Difference (PDD) specification intended to help designers minimize “dead time” in their power inverter designs. Dead time is the time high and low side power transistors are off. Any overlap in Q1 and Q2 conduction will result in large currents flowing through the power devices from the high-voltage to the low-voltage motor rails. To minimize dead time in a given design, the turn on of LED2 should be delayed (relative to the turn off of LED1) so that under worst-case conditions, transistor Q1 has just turned off when transistor Q2 turns on, as shown in Figure 26. The amount of

delay necessary to achieve this condition is equal to the maximum value of the propagation delay difference specification, PDD max, which is specified to be 500 ns over the operating temperature range of -40° to 100°C .

Delaying the LED signal by the maximum propagation delay difference ensures that the minimum dead time is zero, but it does not tell a designer what the maximum dead time will be. The maximum dead time is equivalent to the difference between the maximum and minimum propagation delay difference specification as shown in Figure 27. The maximum dead time for the HCPL-314J is 1 μ s (= 0.5 μ s - (-0.5 μ s)) over the operating temperature range of -40°C to 100°C .

Note that the propagation delays used to calculate PDD and dead time are taken at equal temperatures and test conditions since the optocouplers under consideration are typically mounted in close proximity to each other and are switching identical IGBTs.

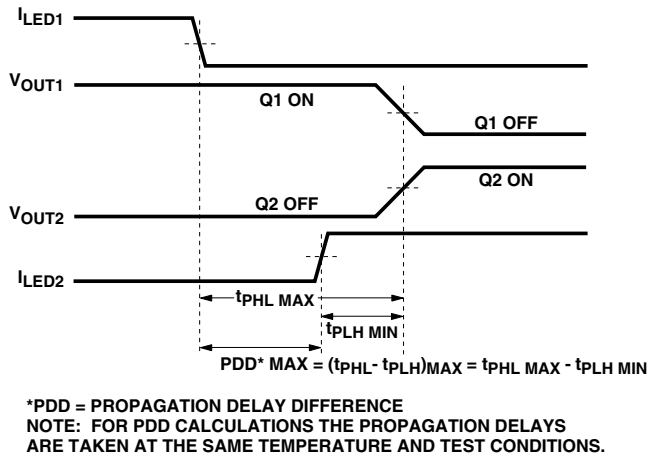


Figure 26. Minimum LED Skew for Zero Dead Time.

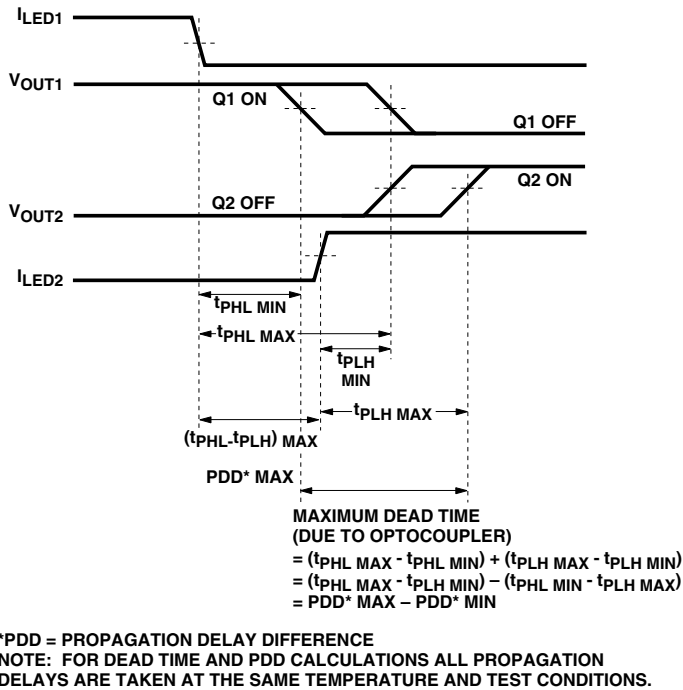


Figure 27. Waveforms for Dead Time.

www.agilent.com/semiconductors

For product information and a complete list of distributors, please go to our web site.

For technical assistance call:

Americas/Canada: +1 (800) 235-0312 or
(916) 788-6763

Europe: +49 (0) 6441 92460

China: 10800 650 0017

Hong Kong: (+65) 6756 2394

India, Australia, New Zealand: (+65) 6755 1939

Japan: (+81 3) 3335-8152 (Domestic/International), or 0120-61-1280 (Domestic Only)

Korea: (+65) 6755 1989

Singapore, Malaysia, Vietnam, Thailand,
Philippines, Indonesia: (+65) 6755 2044

Taiwan: (+65) 6755 1843

Data subject to change.

Copyright © 2005 Agilent Technologies, Inc.

Obsoletes 5989-0782EN

March 1, 2005

5989-2141EN



LittleDiode supplies new, hard to find or obsolete electronic components and semiconductors all over the world.

With over two million different components listed you are sure to find the part you need.

Feel free to visit us today at our online store:

LittleDiode.com

Looking forward to providing you with the best possible service.