

# Agilent HCPL-3180

## 2.0 Amp Output Current

## High Speed Gate Drive

## Optocoupler

### Data Sheet

#### Functional Diagram

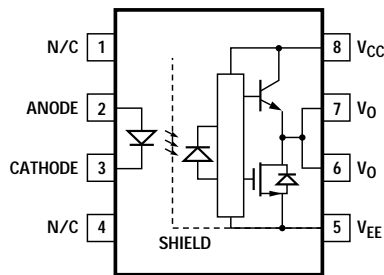

#### Description

This family of devices consists of a GaAsP LED. The LED is optically coupled to an integrated circuit with a power stage. These optocouplers are ideally suited for

high frequency driving of power IGBTs and MOSFETs used in Plasma Display Panels, high performance DC/DC converters, and motor control inverter applications.

#### Features

- 2.0 A minimum peak output current
- 250 kHz maximum switching speed
- High speed response:  
200 ns maximum propagation delay over temperature range
- 10 kV/ $\mu$ s minimum Common Mode Rejection (CMR) at  $V_{CM} = 1500$  V
- Under Voltage Lock-Out protection (UVLO) with hysteresis
- Wide operating temperature range:  $-40^{\circ}\text{C}$  to  $100^{\circ}\text{C}$
- Wide  $V_{CC}$  operating range: 10 V to 20 V
- 20 ns typical pulse width distortion
- Safety approvals:
  - UL approval, 3750  $V_{rms}$  for 1 minute
  - CSA approval
  - IEC/EN/DIN EN 60747-5-2 approval

#### Applications

- Plasma Display Panel (PDP)
- Distributed Power Architecture (DPA)
- Switch Mode Rectifier (SMR)
- High performance DC/DC converter
- High performance Switching Power Supply (SPS)
- High performance Uninterruptible Power Supply (UPS)
- Isolated IGBT/Power MOSFET gate drive

A 0.1  $\mu$ F bypass capacitor must be connected between pins  $V_{CC}$  and Ground.

**CAUTION:** It is advised that normal static precautions be taken in handling and assembly of this component to prevent damage and/or degradation, which may be induced by ESD.

## Ordering Information

Specify part number followed by option number (if desired).

Example:

HCPL-3180-XXXX

- No option = Standard DIP package, 50 per tube.
- 300 = Gull Wing Surface Mount Option, 50 per tube.
- 500 = Tape and Reel Packaging Option, 1000 per reel.
- 060 = IEC/EN/DIN EN 60747-5-2,  $V_{IORM} = 630 V_{PEAK}$ .
- XXXE = Lead Free Option.

## Package Outline Drawings

### HCPL-3180 Standard DIP Package

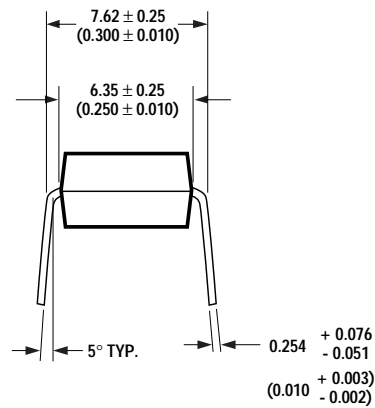
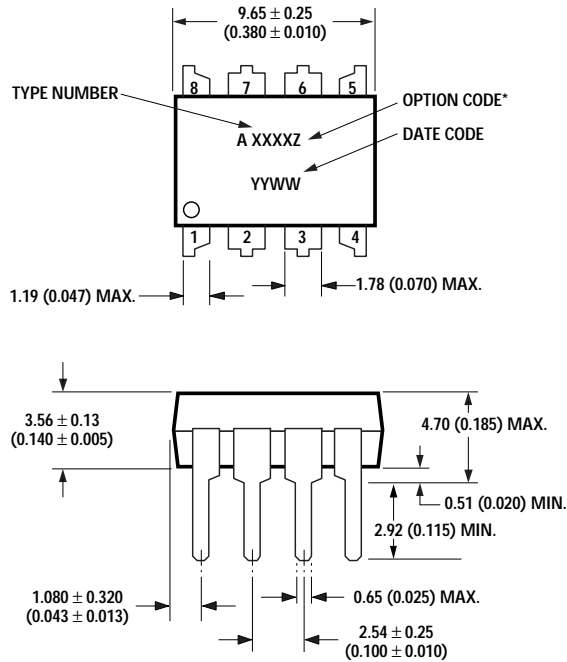

DIMENSIONS IN MILLIMETERS AND (INCHES).

\* MARKING CODE LETTER FOR OPTION NUMBERS

"V" = OPTION 060

OPTION NUMBERS 300 AND 500 NOT MARKED.

NOTE: FLOATING LEAD PROTRUSION IS 0.25 mm (10 mils) MAX.

# HCPL-3180 Gull Wing Surface Mount Option 300

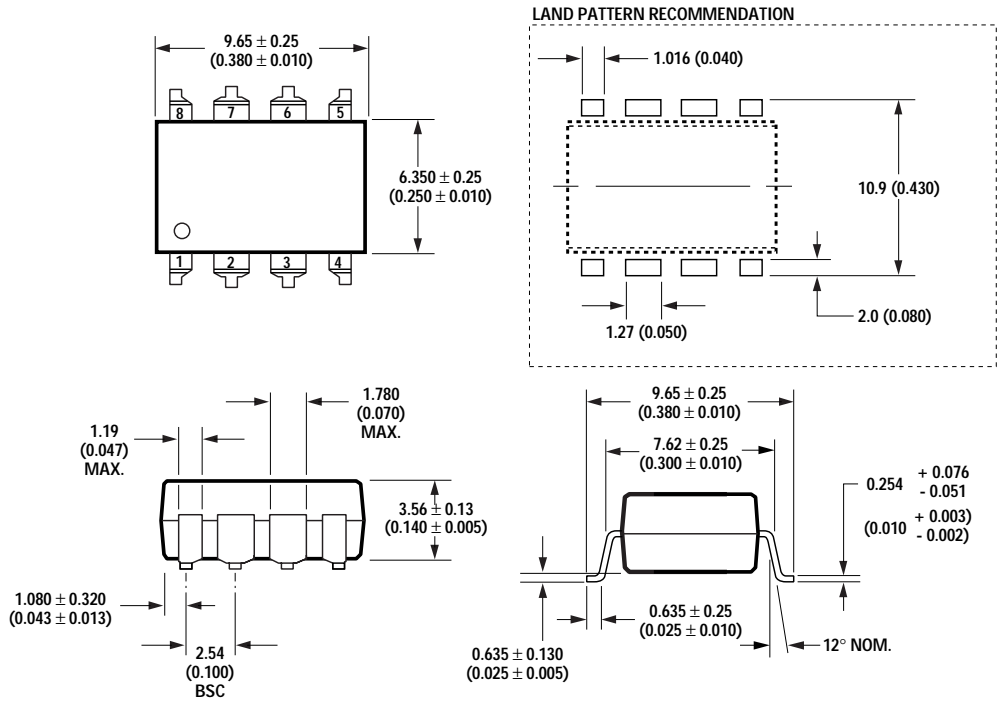

DIMENSIONS IN MILLIMETERS (INCHES).  
 LEAD COPLANARITY = 0.10 mm (0.004 INCHES).  
 NOTE: FLOATING LEAD PROTRUSION IS 0.25 mm (10 mils) MAX.

## Solder Reflow Temperature Profile

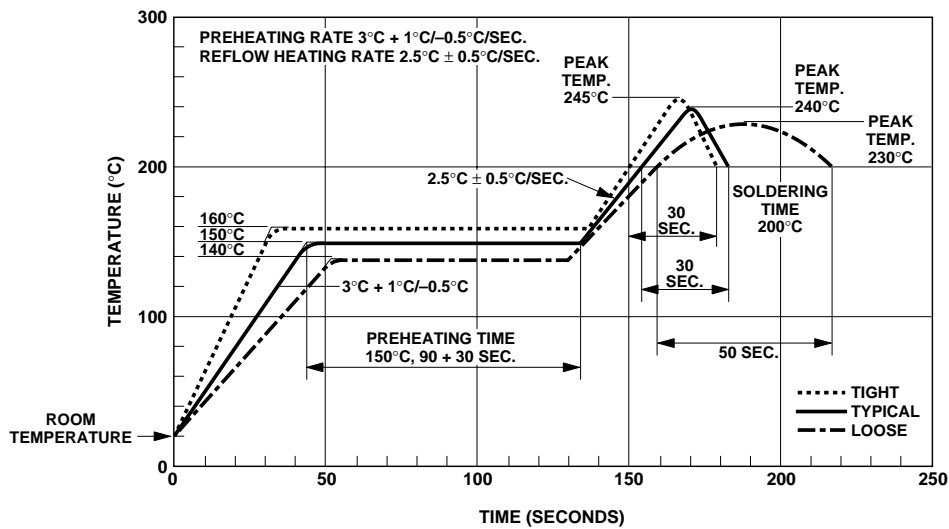

## Recommended Pb-Free IR Profile

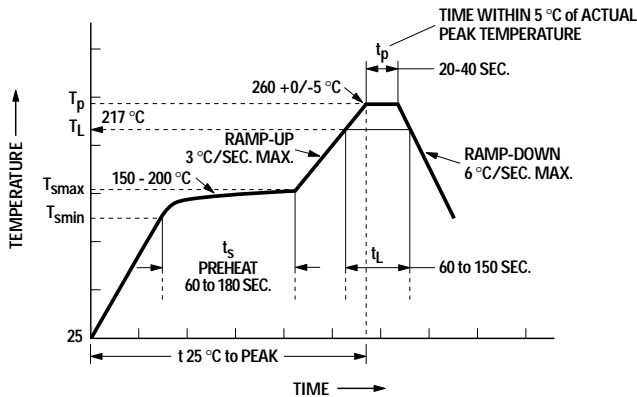

NOTES:  
 THE TIME FROM 25 °C TO PEAK TEMPERATURE = 8 MINUTES MAX.  
 $T_{smax} = 200\text{ °C}$ ,  $T_{smin} = 150\text{ °C}$

## Regulatory Information

The HCPL-3180 has been approved by the following organizations:

### IEC/EN/DIN EN 60747-5-2

Approved under:  
 IEC 60747-5-2:1997 + A1:2002  
 EN 60747-5-2:2001 + A1:2002  
 DIN EN 60747-5-2 (VDE 0884 Teil 2):2003-01  
 (Option 060 only)

### UL

Approval under UL 1577, component recognition program up to  $V_{ISO} = 3750 V_{rms}$ . File E55361.

### CSA

Approval under CSA Component Acceptance Notice #5, File CA 88324.

## IEC/EN/DIN EN 60747-5-2 Insulation Characteristics (HCPL-3180 Option 060)

Description	Symbol	HCPL-3180	Unit
Installation classification per DIN EN 0110 1997-04 for rated mains voltage $\leq 150 V_{rms}$ for rated mains voltage $\leq 300 V_{rms}$ for rated mains voltage $\leq 600 V_{rms}$		I - IV I - III I-II	
Climatic Classification		55/100/21	
Pollution Degree (DIN EN 0110 1997-04)		2	
Maximum Working Insulation Voltage	$V_{IORM}$	630	$V_{peak}$
Input to Output Test Voltage, Method b* $V_{IORM} \times 1.875 = V_{PR}$ , 100% Production Test with $t_m = 1$ sec, Partial Discharge $< 5$ pC	$V_{PR}$	1181	$V_{peak}$
Input to Output Test Voltage, Method a* $V_{IORM} \times 1.5 = V_{PR}$ , Type and Sample Test, $t_m = 60$ sec, Partial Discharge $< 5$ pC	$V_{PR}$	945	$V_{peak}$
Highest Allowable Overvoltage (Transient Overvoltage $t_{ini} = 10$ sec)	$V_{IOTM}$	6000	$V_{peak}$
Safety-limiting values – maximum values allowed in the event of a failure.			
Case Temperature	$T_S$	175	°C
Input Current**	$I_{S, INPUT}$	230	mA
Output Power**	$P_{S, OUTPUT}$	600	mW
Insulation Resistance at $T_S$ , $V_{IO} = 500$ V	$R_S$	$> 10^9$	$\Omega$

\* Refer to the optocoupler section of the Isolation and Control Components Designer's Catalog, under Product Safety Regulations section IEC/EN/DIN EN 60747-5-2 for a detailed description of Method a and Method b partial discharge test profiles.

\*\* Refer to the following figure for dependence of  $P_S$  and  $I_S$  on ambient temperature.

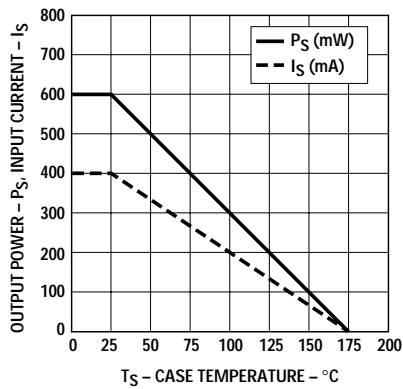

### Insulation and Safety Related Specifications

Parameter	Symbol	HCPL-3180	Units	Conditions
Minimum External Air Gap (Clearance)	L(101)	7.1	mm	Measured from input terminals to output terminals, shortest distance through air.
Minimum External Tracking (Creepage)	L(102)	7.4	mm	Measured from input terminals to output terminals, shortest distance path along body.
Minimum Internal Plastic Gap (Internal Clearance)		0.08	mm	Through insulation distance conductor to conductor, usually the straight line distance thickness between the emitter and detector.
Tracking Resistance (Comparative Tracking Index)	CTI	>175	V	DIN IEC 112/VDE 0303 Part 1
Isolation Group		IIIa		Material Group (DIN VDE 0110, 1/89, Table 1)

Note: Option 300 – surface mount classification is Class A in accordance with CECC 00802.

### Absolute Maximum Ratings

Parameter	Symbol	Min.	Max.	Units	Note
Storage Temperature	T <sub>S</sub>	-55	125	°C	
Junction Temperature	T <sub>J</sub>	-40	125	°C	
Average Input Current	I <sub>F(AVG)</sub>		25	mA	1
Peak Transient Input Current (<1 μs pulse width, 300 pps)	I <sub>F(TRAN)</sub>		1.0	A	
Reverse Input Voltage	V <sub>R</sub>		5	V	
“High” Peak Output Current	I <sub>OH(PEAK)</sub>		2.5	A	2
“Low” Peak Output Current	I <sub>OL(PEAK)</sub>		2.5	A	2
Supply Voltage	V <sub>CC-V<sub>EE</sub></sub>	-0.5	25	V	
Output Voltage	V <sub>O(PEAK)</sub>	0	V <sub>CC</sub>	V	
Output Power Dissipation	P <sub>O</sub>		250	mW	3
Total Power Dissipation	P <sub>T</sub>		295	mW	4
Lead Solder Temperature		260°C for 10 sec., 1.6 mm below seating plane			
Solder Reflow Temperature Profile		See Package Outline Drawings section			

### Recommended Operating Conditions

Parameter	Symbol	Min.	Max.	Units	Note
Power Supply	$V_{CC}-V_{EE}$	10	20	V	
Input Current (ON)	$I_{F(ON)}$	10	16	mA	
Input Voltage (OFF)	$V_{F(OFF)}$	-3.0	0.8	V	
Operating Temperature	$T_A$	-40	100	°C	

### Electrical Specifications (DC)

Over recommended operating conditions unless otherwise specified.

Parameter	Symbol	Min.	Typ.	Max.	Units	Test Conditions	Fig.	Note
High Level Output Current	$I_{OH}$	0.5			A	$V_O = V_{CC} - 4$	2, 3, 17	5
		2.0			A	$V_O = V_{CC} - 10$	2, 3, 17	2
Low Level Output Current	$I_{OL}$	0.5			A	$V_O = V_{EE} + 2.5$	5, 6, 18	5
		2.0			A	$V_O = V_{EE} + 10$	5, 6, 18	2
High Level Output Voltage	$V_{OH}$	$V_{CC} - 4$			V	$I_O = -100$ mA	1, 3, 19	6, 7
Low Level Output Voltage	$V_{OL}$			0.5	V	$I_O = 100$ mA	4, 6, 20	
High Level Supply Current	$I_{CCH}$		3.0	6.0	mA	Output Open $I_F = 10$ to 16 mA	7, 8	
Low Level Supply Current	$I_{CCL}$		3.0	6.0	mA	Output Open $V_F = 3.0$ to 0.8 mA	7, 8	
Threshold Input Current Low to High	$I_{FLH}$			8.0	mA	$I_O = 0$ mA, $V_O > 5$ V	9, 15, 21	
Threshold Input Voltage High to Low	$V_{FHL}$	0.8			V			
Input Forward Voltage	$V_F$	1.2	1.5	1.8	V	$I_F = 10$ mA	16	
Temperature Coefficient of Input Forward Voltage	$\Delta V_F / \Delta T_A$		-1.6		mV/°C	$I_F = 10$ mA		
UVLO Threshold	$V_{UVLO+}$		7.9		V	$I_F = 10$ mA, $V_O > 5$ V	22, 33	
			7.4		V			
UVLO Hysteresis	$UVLO_{HYST}$		0.5		V			
Input Reverse Breakdown Voltage	$BV_R$	5			V	$I_R = 10$ $\mu$ A		
Input Capacitance	$C_{IN}$		60		pF	$f = 1$ MHz, $V_F = 0$ V		

## Switching Specifications (AC)

Over recommended operating conditions unless otherwise specified.

Parameter	Symbol	Min.	Typ.	Max.	Units	Test Conditions	Fig.	Note
Propagation Delay Time to High Output Level	$t_{PLH}$	50	150	200	ns	$I_F = 10\text{ mA}$ , $R_g = 10\ \Omega$ , $f = 250\text{ kHz}$ ,	10, 11, 12, 13,	14
Propagation Delay Time to Low Output Level	$t_{PHL}$	50	150	200	ns		Duty Cycle = 50%,	14, 23
Pulse Width Distortion	PWD		20	65	ns	$C_g = 10\text{ nF}$		10
Propagation Delay Difference Between Any Two Parts or Channels	PDD ( $t_{PHL} - t_{PLH}$ )	-90		90	ns		34, 35	10
Rise Time	$t_r$		25		ns	$CL = 1\text{ nF}$ ,	23	
Fall Time	$t_f$		25		ns	$R_g = 0\ \Omega$		
UVLO turn On Delay	$t_{UVLO\ ON}$		2.0		$\mu\text{s}$		22	
UVLO turn Off Delay	$t_{UVLO\ OFF}$		0.3		$\mu\text{s}$		22	
Output High Level Common Mode Transient Immunity	$ CM_H $	10			$\text{kV}/\mu\text{s}$	$T_A = 25^\circ\text{C}$ , $I_F = 10\text{ to }16\text{ mA}$ ,	24	11, 12
Output Low Level Common Mode Transient Immunity	$ CM_L $	10			$\text{kV}/\mu\text{s}$	$V_{CM} = 1.5\text{ kV}$ , $V_{CC} = 20\text{ V}$	24	11, 13

## Package Characteristics

Parameter	Symbol	Min.	Typ.	Max.	Units	Test Conditions	Fig.	Note
Input-Output Momentary Withstand Voltage	$V_{ISO}$	3750			$V_{rms}$	$T_A = 25^\circ\text{C}$ , $RH < 50\%$		8, 9
Input-Output Resistance	$R_{I-O}$		10 <sup>[11]</sup>		$\Omega$	$V_{I-O} = 500\text{ V}$		9
Input-Output Capacitance	$C_{I-O}$		1		$\text{pF}$	Freq = 1 MHz		

### Notes:

- Derate linearly above +70°C free air temperature at a rate of 0.3 mA/°C.
- Maximum pulse width = 10  $\mu\text{s}$ , maximum duty cycle = 0.2%. This value is intended to allow for component tolerances for designs with IO peak minimum = 2.0 A. See Application section for additional details on limiting IOL peak.
- Derate linearly above +70°C, free air temperature at the rate of 4.8 mW/°C.
- Derate linearly above +70°C, free air temperature at the rate of 5.4 mW/°C. The maximum LED junction temperature should not exceed +125°C.
- Maximum pulse width = 50  $\mu\text{s}$ , maximum duty cycle = 0.5%.
- In this test,  $V_{OH}$  is measured with a dc load current. When driving capacitive load  $V_{OH}$  will approach  $V_{CC}$  as  $I_{OH}$  approaches zero amps.
- Maximum pulse width = 1 ms, maximum duty cycle = 20%.
- In accordance with UL 1577, each optocoupler is proof tested by applying an insulation test voltage > 4500  $V_{rms}$  for 1 second (leakage detection current limit  $I_{I-O} < 5\ \mu\text{A}$ ).
- Device considered a two-terminal device: pins on input side shorted together and pins on output side shorted together.
- PWD is defined as  $|t_{PHL} - t_{PLH}|$  for any given device.
- Pin 1 and 4 need to be connected to LED common.
- Common mode transient immunity in the high state is the maximum tolerable  $dV_{CM}/dt$  of the common mode pulse  $V_{CM}$  to assure that the output will remain in the high state (i.e.  $V_O > 10.0\text{ V}$ ).
- Common mode transient immunity in a low state is the maximum tolerable  $dV_{CM}/dt$  of the common mode pulse,  $V_{CM}$ , to assure that the output will remain in a low state (i.e.  $V_O < 1.0\text{ V}$ ).
- $t_{PHL}$  propagation delay is measured from the 50% level on the falling edge of the input pulse to the 50% level of the falling edge of the  $V_O$  signal.  
 $t_{PLH}$  propagation delay is measured from the 50% level on the rising edge of the input pulse to the 50% level of the rising edge of the  $V_O$  signal.
- The difference between  $t_{PHL}$  and  $t_{PLH}$  between any two HCPL-3180 parts under same test conditions.

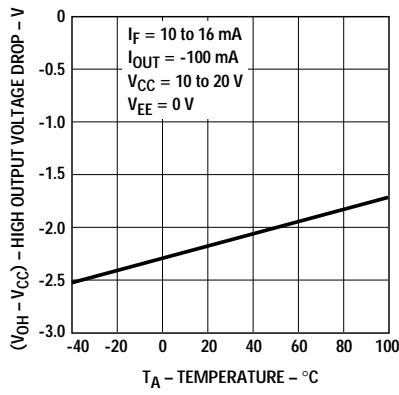

Figure 1.  $V_{OH}$  vs. temperature.

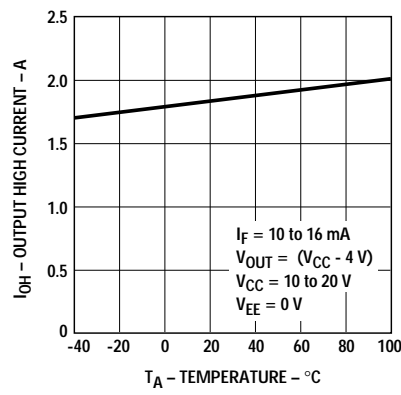

Figure 2.  $I_{OH}$  vs. temperature.

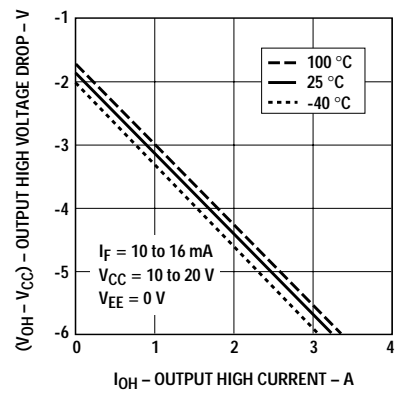

Figure 3.  $V_{OH}$  vs.  $I_{OH}$ .

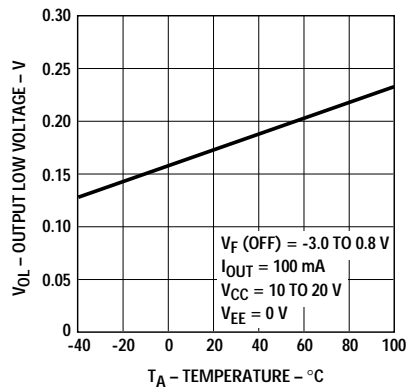

Figure 4.  $V_{OL}$  vs. temperature.

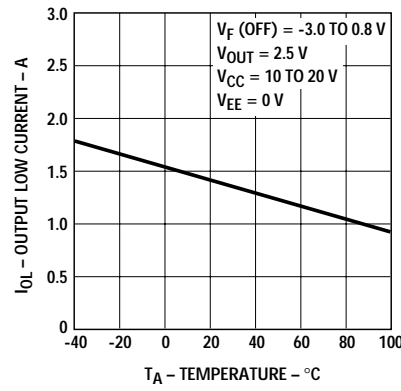

Figure 5.  $I_{OL}$  vs. temperature.

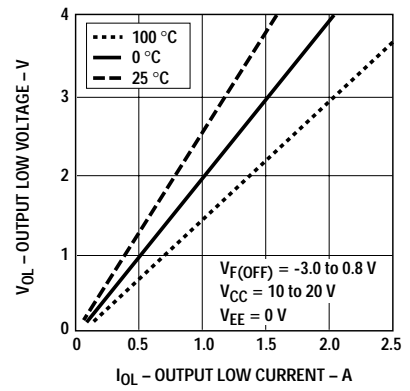

Figure 6.  $V_{OL}$  vs.  $I_{OL}$ .

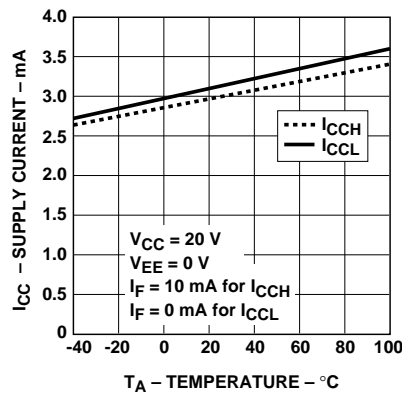

Figure 7.  $I_{CC}$  vs. temperature.

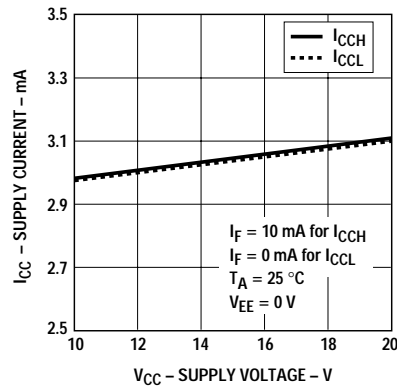

Figure 8.  $I_{CC}$  vs.  $V_{CC}$ .

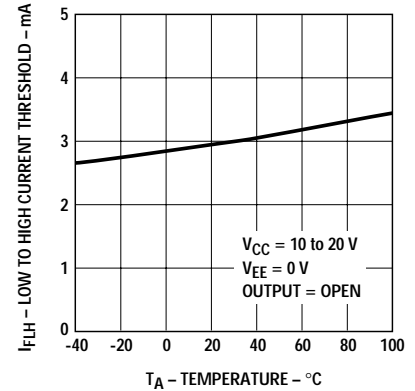

Figure 9.  $I_{FLH}$  vs. temperature.

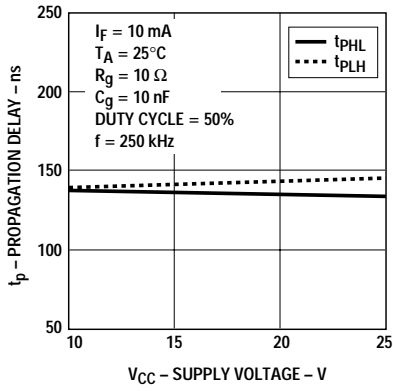

Figure 10. Propagation delay vs.  $V_{CC}$ .

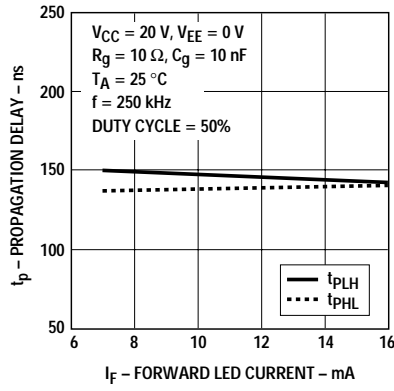

Figure 11. Propagation delay vs.  $I_F$ .

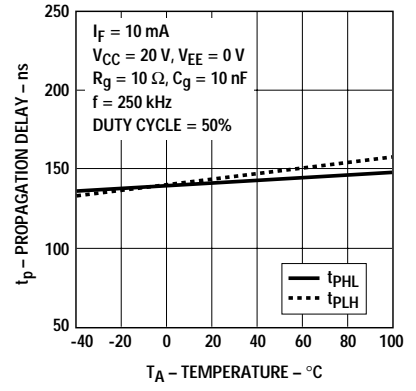

Figure 12. Propagation delay vs. temperature.

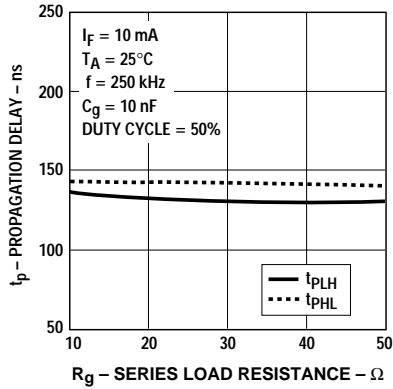

Figure 13. Propagation delay vs.  $R_g$ .

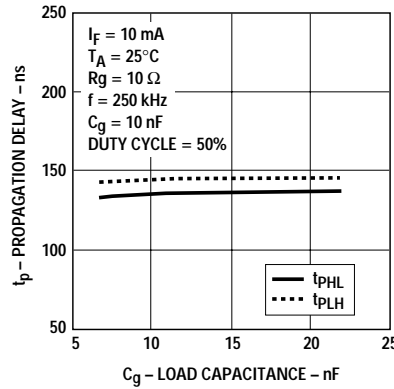

Figure 14. Propagation delay vs.  $C_g$ .

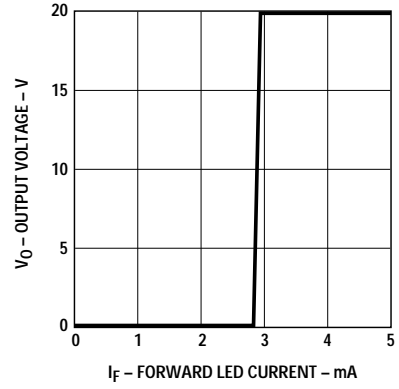

Figure 15. Transfer characteristics.

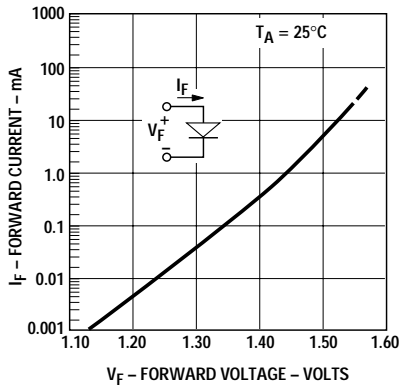

Figure 16. Input current vs. forward voltage.

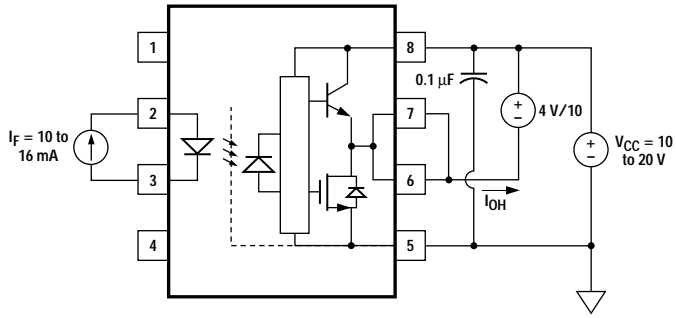

Figure 17.  $I_{OH}$  test circuit.

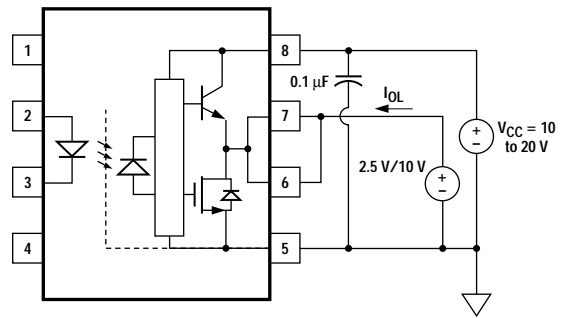

Figure 18.  $I_{OL}$  test circuit.

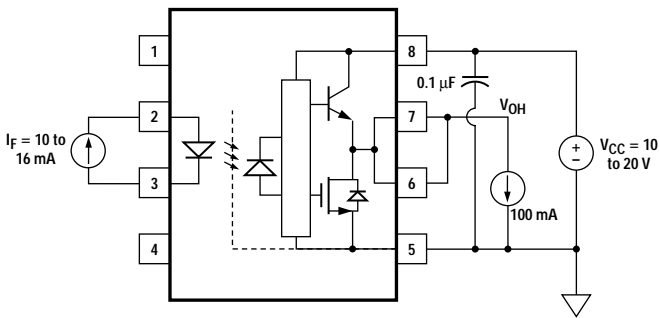

Figure 19.  $V_{OH}$  test circuit.

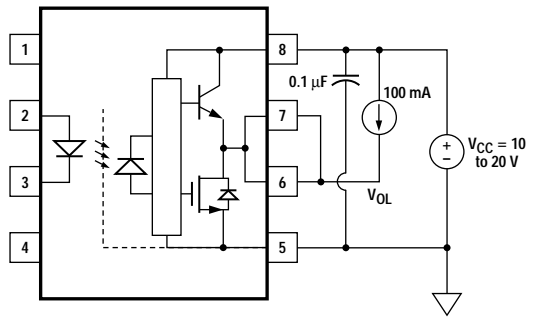

Figure 20.  $V_{OL}$  test circuit.

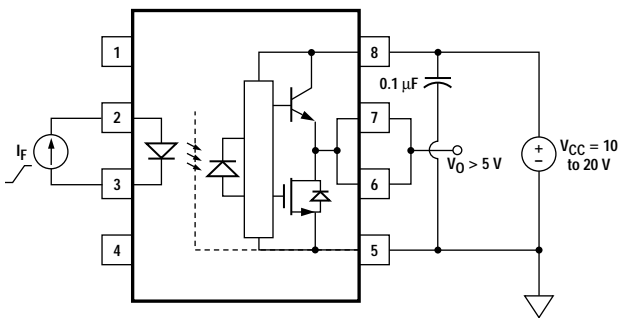

Figure 21.  $I_{FLH}$  test circuit.

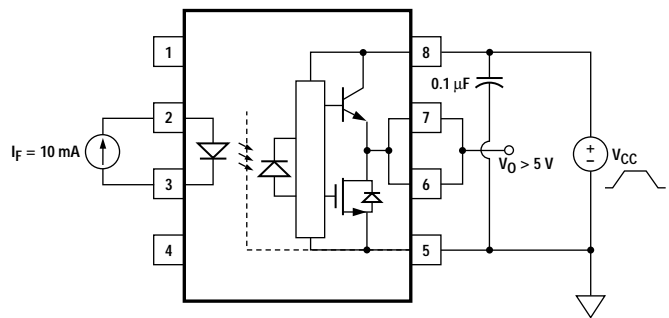

Figure 22. UVLO test circuit.

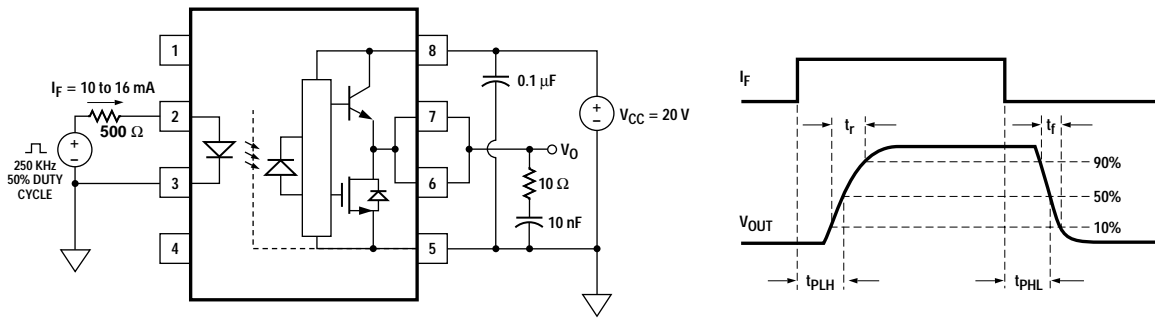

Figure 23.  $t_{PLH}$ ,  $t_{PHL}$ ,  $t_r$  and  $t_f$  test circuit and waveform.

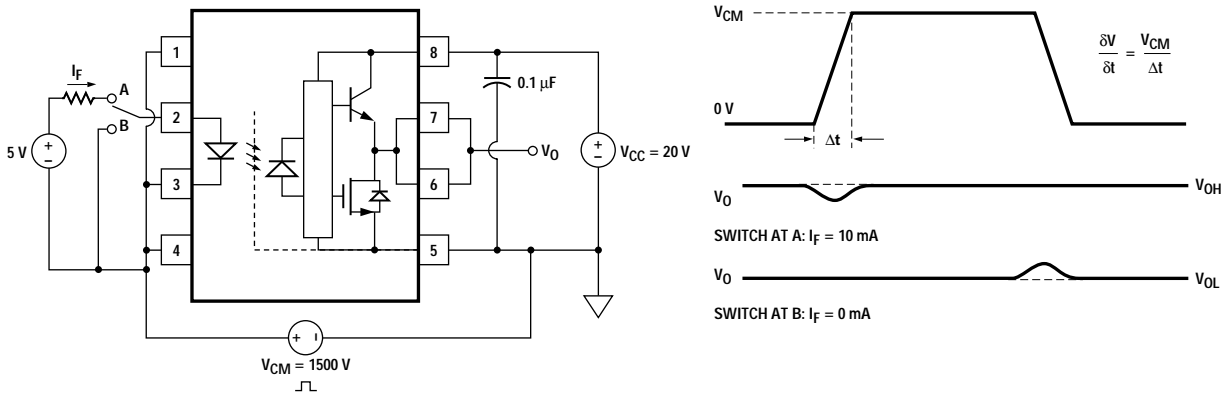

Figure 24. CMR test circuit and waveform.

### Applications Information Eliminating Negative IGBT Gate Drive

To keep the IGBT firmly off, the HCPL-3180 has a very low maximum  $V_{OL}$  specification of 0.4 V. The HCPL-3180 realizes the very low  $V_{OL}$  by using a DMOS transistor with 1  $\Omega$  (typical) on resistance in its pull down circuit. When the HCPL-3180 is in the low state, the IGBT gate is shorted to the emitter

by  $R_g + 1 \Omega$ . Minimizing  $R_g$  and the lead inductance from the HCPL-3180 to the IGBT gate and emitter (possibly by mounting HCPL-3180 on a small PC board directly above the IGBT) can eliminate the need for negative IGBT gate drive in many applications as shown in Figure 25. Care should be taken with such a PC board design to avoid routing the IGBT collector or

emitter traces close to the HCPL-3180 input as this can result in unwanted coupling of transient signals into the input of HCPL-3180 and degrade performance.

(If the IGBT drain must be routed near the HCPL-3180 input, then the LED should be reverse biased when in the off state to prevent the transient signals coupled from the IGBT drain from turning on the HCPL-3180.)

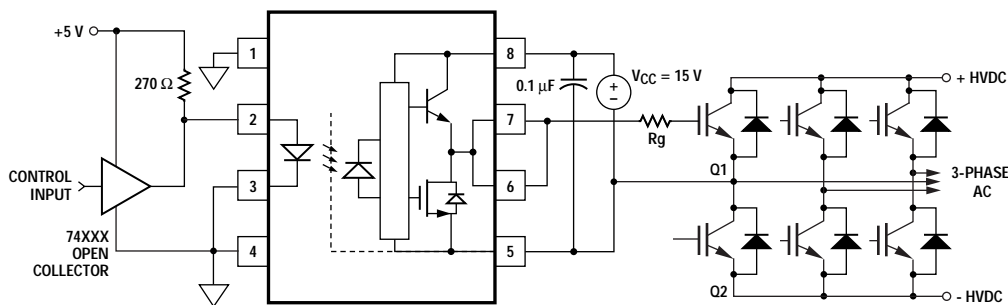

Figure 25. Recommended LED drive and application circuit for HCPL-3180.

### Selecting the Gate Resistor ( $R_g$ ) for HCPL-3180

**Step 1:** Calculate  $R_g$  minimum from the  $I_{OL}$  peak specification. The IGBT and  $R_g$  in Figure 25 can be analyzed as a simple RC circuit with a voltage supplied by the HCPL-3180.

$$\begin{aligned} R_g &\geq \frac{V_{CC} - V_{OL}}{I_{OLPEAK}} \\ &= \frac{20 - 3}{2} \\ &= 8.5 \Omega \end{aligned}$$

The  $V_{OL}$  value of 3 V in the previous equation is the  $V_{OL}$  at the peak current of 2 A. (See Figure 6.)

**Step 2:** Check the HCPL-3180 power dissipation and increase  $R_g$  if necessary. The HCPL-3180 total power dissipation ( $P_T$ ) is equal to the sum of the emitter power ( $P_E$ ) and the output power ( $P_O$ ).

$$P_T = P_E + P_O$$

$$P_E = I_F * V_F * \text{Duty Cycle}$$

$$\begin{aligned} P_O &= P_{O(BIAS)} + P_{O(SWITCHING)} \\ &= I_{CC} * V_{CC} + E_{SW} (R_g; Q_g) * f \end{aligned}$$

For the circuit in Figure 25 with  $I_F$  (worst case) = 16 mA,  $R_g = 10 \Omega$ , Max Duty Cycle = 80%,  $Q_g = 100 \text{ nC}$ ,  $f = 200 \text{ kHz}$  and  $T_{AMAX} = +75^\circ\text{C}$ :

$$P_E = 16 \text{ mA} * 1.8 \text{ V} * 0.8 = 23 \text{ mW}$$

$$\begin{aligned} P_O &= 4.5 \text{ mA} * 20 \text{ V} + 0.85 \mu * 200 \text{ kHz} \\ &= 260 \text{ mW} \geq 226 \text{ mW} (P_{O(MAX)} @ 75^\circ\text{C} = 250 \text{ mW} (5^\circ\text{C} * 4.8 \text{ mW}/^\circ\text{C})) \end{aligned}$$

The value of 4.5 mA for  $I_{CC}$  in the previous equation was obtained by derating the  $I_{CC}$  max of 6 mA to  $I_{CC}$  max at  $+75^\circ\text{C}$ . Since  $P_O$  for this case is greater than the  $P_{O(MAX)}$ ,  $R_g$  must be increased to reduce the HCPL-3180 power dissipation.

$$\begin{aligned} P_{O(SWITCHING MAX)} &= P_{O(MAX)} - P_{O(BIAS)} \\ &= 226 \text{ mW} - 90 \text{ mW} \\ &= 136 \text{ mW} \end{aligned}$$

$$\begin{aligned} E_{SW(MAX)} &= \frac{P_{O(SWITCHING MAX)}}{f} \\ &= \frac{136 \text{ mW}}{200 \text{ kHz}} \\ &= 0.68 \mu\text{W} \end{aligned}$$

For  $Q_g = 100 \text{ nC}$ , a value of  $E_{SW} = 0.68 \mu\text{W}$  gives a  $R_g = 15 \Omega$ .

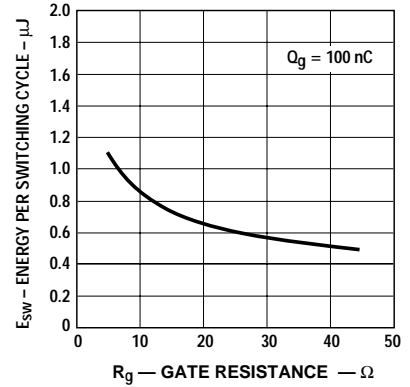

Figure 26. Energy dissipated in the HCPL-3180 and for each IGBT.

**Thermal Model  
(Discussion applies to HCPL-3180)**

The steady state thermal model for the HCPL-3180 is shown in Figure 27. The thermal resistance values given in this model can be used to calculate the temperatures at each node for a given operating condition. As shown by the model, all heat generated

flows through  $\theta_{CA}$  which raises the case temperature  $T_C$  accordingly. The value of  $\theta_{CA}$  depends on the conditions of the board design and is, therefore, determined by the designer. The value of  $\theta_{CA} = +83^\circ\text{C/W}$  was obtained from thermal measurements using a 2.5 x 2.5 inch PC board, with small traces (no ground plane), a

single HCPL- 3180 soldered into the center of the board and still air. The absolute maximum power dissipation derating specifications assume a  $\theta_{CA}$  value of  $+83^\circ\text{C/W}$ . From the thermal mode in Figure 27, the LED and detector IC junction temperatures can be expressed as:

$$T_{JE} = P_E * (\theta_{LC} // \theta_{LD} + \theta_{DC}) + \theta_{CA} + P_D * \left[ \frac{\theta_{LC} * \theta_{DC}}{\theta_{LC} + \theta_{DC} + \theta_{LD}} + \theta_{CA} \right] + T_A$$

$$T_{JD} = P_E * \left[ \frac{\theta_{LC} * \theta_{DC}}{\theta_{LC} + \theta_{DC} + \theta_{LD}} + \theta_{CA} \right] + P_D * (\theta_{LC} // \theta_{LD} + \theta_{DC}) + \theta_{CA} + T_A$$

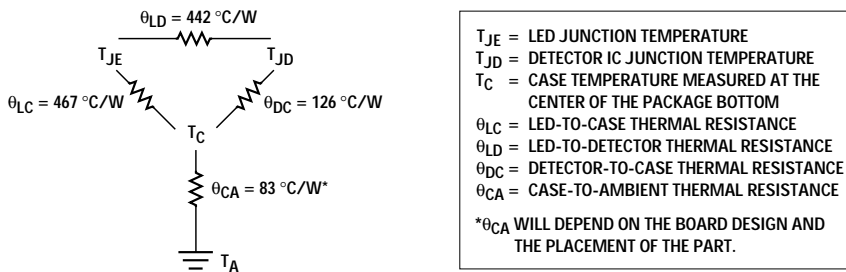

$T_{JE}$  = LED JUNCTION TEMPERATURE  
 $T_{JD}$  = DETECTOR IC JUNCTION TEMPERATURE  
 $T_C$  = CASE TEMPERATURE MEASURED AT THE CENTER OF THE PACKAGE BOTTOM  
 $\theta_{LC}$  = LED-TO-CASE THERMAL RESISTANCE  
 $\theta_{LD}$  = LED-TO-DETECTOR THERMAL RESISTANCE  
 $\theta_{DC}$  = DETECTOR-TO-CASE THERMAL RESISTANCE  
 $\theta_{CA}$  = CASE-TO-AMBIENT THERMAL RESISTANCE  
 \* $\theta_{CA}$  WILL DEPEND ON THE BOARD DESIGN AND THE PLACEMENT OF THE PART.

Figure 27. Thermal model.

$$T_{JE} = P_E * (256^\circ\text{C/W} + \theta_{CA}) + P_D * (57^\circ\text{C/W} + \theta_{CA}) + T_A$$

$$T_{JD} = P_E * (57^\circ\text{C/W} + \theta_{CA}) + P_D * (111^\circ\text{C/W} + \theta_{CA}) + T_A$$

For example, given  $P_E = 45\text{ mW}$ ,  
 $P_O = 250\text{ mW}$ ,  $T_A = +70^\circ\text{C}$  and  $\theta_{CA} = +83^\circ\text{C/W}$ :

$$\begin{aligned} T_{JE} &= P_E * 339^\circ\text{C/W} + P_D * 140^\circ\text{C/W} + T_A \\ &= 45\text{ mW} * 339^\circ\text{C/W} + 250\text{ mW} * 140^\circ\text{C/W} + 70^\circ\text{C} \\ &= 120^\circ\text{C} \end{aligned}$$

$$\begin{aligned} T_{JD} &= P_E * 140^\circ\text{C/W} + P_D * 194^\circ\text{C/W} + T_A \\ &= 45\text{ mW} * 140^\circ\text{C/W} + 250\text{ mW} * 194^\circ\text{C/W} + 70^\circ\text{C} \\ &= 125^\circ\text{C} \end{aligned}$$

$T_{JE}$  and  $T_{JD}$  should be limited to  $+125^\circ\text{C}$  based on the board layout and part placement ( $\theta_{CA}$ ) specific to the application.

### LED Drive Circuit Considerations for Ultra High CMR Performance

Without a detector shield, the dominant cause of optocoupler CMR failure is capacitive coupling from the input side of the optocoupler, through the package, to the detector IC as shown in Figure 28. The HCPL-3180 improves CMR performance by using a detector IC with an optically transparent Faraday shield, which

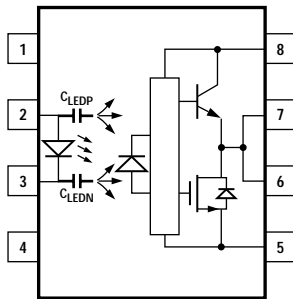

Figure 28. Optocoupler input to output capacitance model for unshielded optocouplers.

diverts the capacitively coupled current away from the sensitive IC circuitry. However, this shield does not eliminate the capacitive coupling between the LED and optocoupler pins 5-8 as shown in Figure 29. This capacitive coupling causes perturbations in the LED current during common mode transients and becomes the major source of CMR failures for a shielded optocoupler. The main

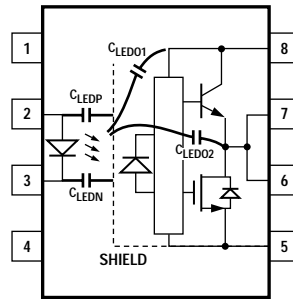

Figure 29. Optocoupler input to output capacitance model for shielded optocouplers.

design objective of a high CMR LED drive circuit becomes keeping the LED in the proper state (on or off) during common mode transients. For example, the recommended application circuit (Figure 25), can achieve  $10 \text{ kV}/\mu\text{s}$  CMR while minimizing component complexity.

Techniques to keep the LED in the proper state are discussed in the next two sections.

### CMR with the LED On ( $\text{CMR}_H$ )

A high CMR LED drive circuit must keep the LED on during common mode transients. This is achieved by over-driving the LED current beyond the input threshold so that it is not pulled below the threshold during a transient. A minimum LED current of  $10 \text{ mA}$  provides adequate margin over the maximum  $I_{FLH}$  of  $8 \text{ mA}$  to achieve  $10 \text{ kV}/\mu\text{s}$  CMR.

### CMR with the LED Off ( $\text{CMR}_L$ )

A high CMR LED drive circuit must keep the LED off ( $V_F \leq V_{F(OFF)}$ ) during common mode transients. For example, during a  $-dV_{CM}/dt$  transient in Figure 30, the current flowing through  $C_{LEDP}$  also flows through the  $R_{SAT}$  and  $V_{SAT}$  of the logic gate. As long as the low state voltage developed across the logic gate is less than  $V_{F(OFF)}$ , the LED will remain off and no common mode failure will occur.

The open collector drive circuit, shown in Figure 31, cannot keep the LED off during a  $+dV_{CM}/dt$  transient, since all the current flowing through  $C_{LEDN}$  must be supplied by the LED, and it is not recommended for applications requiring ultra high  $\text{CMR}_L$

performance. Figure 32 is an alternative drive circuit, which like the recommended application circuit (Figure 25), does achieve ultra high CMR performance by shunting the LED in the off state.

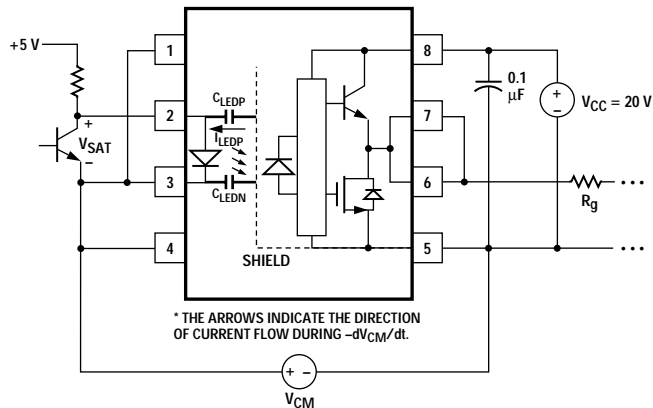

Figure 30. Equivalent circuit for Figure 25 during common mode transient.

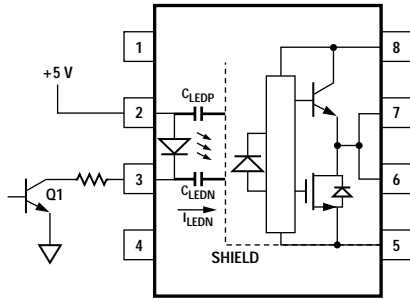

Figure 31. Not recommended open collector drive circuit.

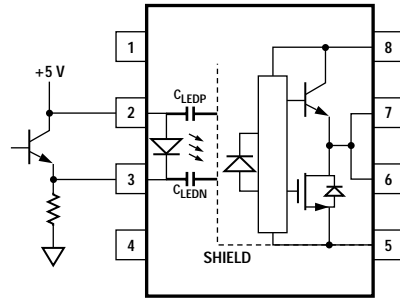

Figure 32. Recommended LED drive circuit for ultra-high CMR.

### Under Voltage Lockout Feature

The HCPL-3180 contains an under voltage lockout (UVLO) feature that is designed to protect the IGBT under fault conditions which cause the HCPL-3180 supply voltage (equivalent to the fully charged IGBT gate voltage) to drop below a level necessary to keep the IGBT in a low resistance state. When the HCPL-3180 output is in the high state and the supply voltage drops below the HCPL-3180  $V_{UVLO-}$  threshold (typ 7.5 V) the optocoupler output will go into the low state. When the HCPL-3180 output is in the low state and the supply voltage rises above the HCPL-3180  $V_{UVLO+}$  threshold (typ 8.5 V) the optocoupler output will go into the high state (assume LED is “ON”).

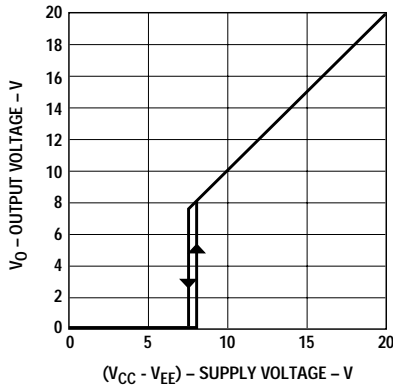
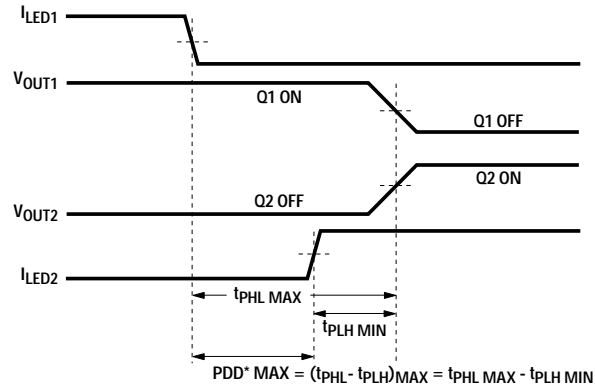

Figure 33. Under voltage lock out.

### IPM Dead Time and Propagation Delay Specifications

The HCPL-3180 includes a Propagation Delay Difference (PDD) specification intended to help designers minimize “dead time” in their power inverter designs. Dead time is the time during which the high and low side power transistors are off. Any overlap in Q1 and Q2 conduction will result in large currents flowing through the power devices from the high voltage to the low-voltage motor rails.

To minimize dead time in a given design, the turn on of LED2 should be delayed (relative to the turn off of LED1) so that under worst-case conditions, transistor Q1 has just turned off when transistor Q2 turns on, as shown in Figure 34. The amount of delay necessary to achieve this condition is equal to the maximum value of the propagation delay difference specification,  $PDD_{MAX}$ , which is specified to be 90 ns over the operating temperature range of  $-40^{\circ}C$  to  $+100^{\circ}C$ .



\*PDD = PROPAGATION DELAY DIFFERENCE  
NOTE: FOR PDD CALCULATIONS, THE PROPAGATION DELAYS ARE TAKEN AT THE SAME TEMPERATURE AND TEST CONDITIONS.

Figure 34. Minimum LED skew for zero dead time.

Delaying the LED signal by the maximum propagation delay difference ensures that the minimum dead time is zero, but it does not tell a designer what the maximum dead time will be. The maximum dead time is equivalent to the difference between the maximum

and minimum propagation delay difference specification as shown in Figure 35. The maximum dead time for the HCPL-3180 is 180 ns (= 90 ns - (-90 ns)) over the operating temperature range of -40 °C to +100 °C.

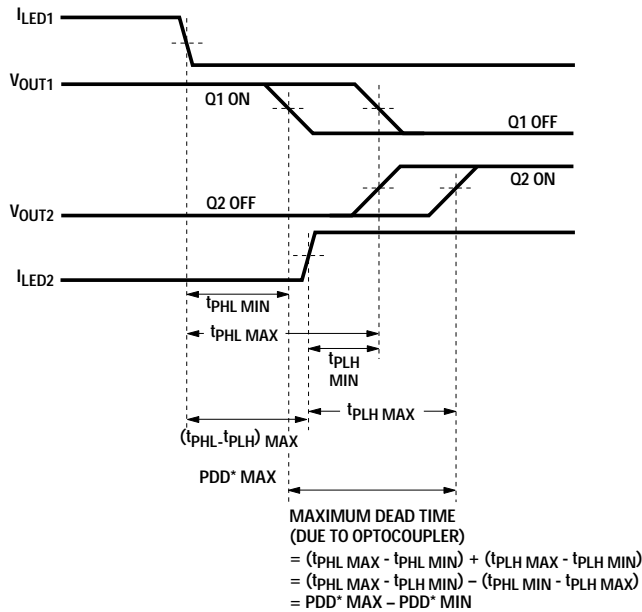

\*PDD = PROPAGATION DELAY DIFFERENCE

NOTE: FOR DEAD TIME AND PDD CALCULATIONS, ALL PROPAGATION DELAYS ARE TAKEN AT THE SAME TEMPERATURE AND TEST CONDITIONS.

Figure 35. Waveforms for dead time.

Note that the propagation delays used to calculate PDD and dead time are taken at equal temperatures and test conditions since the optocouplers under consideration are typically mounted in close proximity to each other and are switching identical IGBTs.

**[www.agilent.com/semiconductors](http://www.agilent.com/semiconductors)**

For product information and a complete list of distributors, please go to our web site.

For technical assistance call:

Americas/Canada: +1 (800) 235-0312 or  
(916) 788-6763

Europe: +49 (0) 6441 92460

China: 10800 650 0017

Hong Kong: (+65) 6756 2394

India, Australia, New Zealand: (+65) 6755 1939

Japan: (+81 3) 3335-8152 (Domestic/International), or 0120-61-1280 (Domestic Only)

Korea: (+65) 6755 1989

Singapore, Malaysia, Vietnam, Thailand,  
Philippines, Indonesia: (+65) 6755 2044

Taiwan: (+65) 6755 1843

Data subject to change.

Copyright © 2005 Agilent Technologies, Inc.

Obsoletes 5989-1637EN

March 1, 2005

5989-2145EN



**Agilent Technologies**



LittleDiode supplies new, hard to find or obsolete electronic components and semiconductors all over the world.

With over two million different components listed you are sure to find the part you need.

Feel free to visit us today at our online store:

[LittleDiode.com](http://LittleDiode.com)

Looking forward to providing you with the best possible service.