

To all our customers

---

## **Regarding the change of names mentioned in the document, such as Hitachi Electric and Hitachi XX, to Renesas Technology Corp.**

---

The semiconductor operations of Mitsubishi Electric and Hitachi were transferred to Renesas Technology Corporation on April 1st 2003. These operations include microcomputer, logic, analog and discrete devices, and memory chips other than DRAMs (flash memory, SRAMs etc.) Accordingly, although Hitachi, Hitachi, Ltd., Hitachi Semiconductors, and other Hitachi brand names are mentioned in the document, these names have in fact all been changed to Renesas Technology Corp. Thank you for your understanding. Except for our corporate trademark, logo and corporate statement, no changes whatsoever have been made to the contents of the document, and these changes do not constitute any alteration to the contents of the document itself.

Renesas Technology Home Page: <http://www.renesas.com>

Renesas Technology Corp.  
Customer Support Dept.  
April 1, 2003

## Cautions

Keep safety first in your circuit designs!

1. Renesas Technology Corporation puts the maximum effort into making semiconductor products better and more reliable, but there is always the possibility that trouble may occur with them. Trouble with semiconductors may lead to personal injury, fire or property damage.  
Remember to give due consideration to safety when making your circuit designs, with appropriate measures such as (i) placement of substitutive, auxiliary circuits, (ii) use of nonflammable material or (iii) prevention against any malfunction or mishap.

Notes regarding these materials

1. These materials are intended as a reference to assist our customers in the selection of the Renesas Technology Corporation product best suited to the customer's application; they do not convey any license under any intellectual property rights, or any other rights, belonging to Renesas Technology Corporation or a third party.
2. Renesas Technology Corporation assumes no responsibility for any damage, or infringement of any third-party's rights, originating in the use of any product data, diagrams, charts, programs, algorithms, or circuit application examples contained in these materials.
3. All information contained in these materials, including product data, diagrams, charts, programs and algorithms represents information on products at the time of publication of these materials, and are subject to change by Renesas Technology Corporation without notice due to product improvements or other reasons. It is therefore recommended that customers contact Renesas Technology Corporation or an authorized Renesas Technology Corporation product distributor for the latest product information before purchasing a product listed herein.  
The information described here may contain technical inaccuracies or typographical errors.  
Renesas Technology Corporation assumes no responsibility for any damage, liability, or other loss rising from these inaccuracies or errors.  
Please also pay attention to information published by Renesas Technology Corporation by various means, including the Renesas Technology Corporation Semiconductor home page (<http://www.renesas.com>).
4. When using any or all of the information contained in these materials, including product data, diagrams, charts, programs, and algorithms, please be sure to evaluate all information as a total system before making a final decision on the applicability of the information and products. Renesas Technology Corporation assumes no responsibility for any damage, liability or other loss resulting from the information contained herein.
5. Renesas Technology Corporation semiconductors are not designed or manufactured for use in a device or system that is used under circumstances in which human life is potentially at stake. Please contact Renesas Technology Corporation or an authorized Renesas Technology Corporation product distributor when considering the use of a product contained herein for any specific purposes, such as apparatus or systems for transportation, vehicular, medical, aerospace, nuclear, or undersea repeater use.
6. The prior written approval of Renesas Technology Corporation is necessary to reprint or reproduce in whole or in part these materials.
7. If these products or technologies are subject to the Japanese export control restrictions, they must be exported under a license from the Japanese government and cannot be imported into a country other than the approved destination.  
Any diversion or reexport contrary to the export control laws and regulations of Japan and/or the country of destination is prohibited.
8. Please contact Renesas Technology Corporation for further details on these materials or the products contained therein.

---

# HD404889/HD404899/HD404878/ HD404868 Series

Low-Voltage AS Microcomputers with On-Chip LCD Circuit



ADE-202-075D (O)  
Rev. 5.0  
Feb. 2000

---

## Description

The HD404889, HD404899, and HD404868 Series comprise low-voltage, 4-bit single-chip microcomputers with a variety of on-chip supporting functions that include an LCD circuit, A/D converter, multifunctional timers, and large-current I/O pins. These devices are suitable for system and display panel control in a wide range of applications, including pagers, remote controllers, and home appliances equipped with an LCD display.

The HD404878 Series comprises low-voltage, 4-bit single-chip microcomputers with no on-chip A/D converter.

Each series is equipped with a 32.768 kHz sub-resonator for realtime clock use, providing a time counting facility, and a variety of low-power modes to reduce current drain.

The HD4074889, HD4074899, and HD4074869 are ZTAT™ microcomputers with on-chip PROM that drastically shortens development time and ensures a smooth transition from debugging to mass production. (The PROM programming specifications are the same as for the 27256 type.)

ZTAT™: Zero Turn-Around Time. ZTAT™ is a trademark of Hitachi, Ltd.

## Features

- 46 I/O pins (HD404889/HD404899/HD404878 Series)  
41 I/O pins (HD404868 Series)  
Large-current I/O pins (source: 10 mA max.):4  
Large-current I/O pins (sink: 15 mA max.): 8 (HD404889/HD404899/HD404878 Series)  
6 (HD404868 Series)  
LCD segment multiplexed pins:16  
Analog input multiplexed pins: 6 (HD404889 and HD404899 Series)  
4 (HD404868 Series)

---

## HD404889/HD404899/HD404878/HD404868 Series

---

- Four Timer/counters  
8-bit timer: 2 (HD404889/HD404899/HD404878 Series)  
1 (HD404868 Series)  
16-bit timer:1 (Can also be used as two 8-bit timer)
- 8-bit input capture circuit (HD404889/HD404899/HD404878 Series)
- Two timer outputs (including PWM out-put)
- Two event counter inputs (edge-programmable) (HD404889/HD404899/HD404878 Series)  
One event counter input (edge-programmable) (HD404868 Series)
- Clock-synchronous 8-bit serial interface
- A/D converter  
6 channels × 8-bit (HD404889 Series)  
6 channels × 10-bit (HD404899 Series)  
4 channels × 10-bit (HD404868 Series)
- LCD controller/driver (32 segments × 4 commons) (HD404889/HD404899/HD404878 Series)  
(24 segments × 4 commons) (HD404868 Series)
- On-chip oscillators  
— Main clock (ceramic resonator, crystal resonator, or external clock operation possible)  
— Sub-clock (32.768 kHz crystal resonator)
- Interrupts  
External: 3 (including one edge-programmable)  
Internal : 6 (HD404889 and HD404899 Series)  
: 5 (HD404878 and HD404868 Series)
- Subroutine stack up to 16 levels, including interrupts
- Four Low-power dissipation modes
- Module standby (timers, serial interface, A/D converter)
- System clock division software switching (1/4 or 1/32)
- Inputs for return from stop mode (wake-up): 4
- Instruction execution time  
Min. 0.89  $\mu$ s ( $f_{osc} = 4.5$  MHz)
- Operation voltage  
1.8 V to 5.5 V

### Cautions about operation!

- Electrical properties presented on the data sheet for the mask ROM and ZTAT™ versions will surely and sufficiently satisfy the standard values. However, real capabilities, operation margin, noise margin, and other properties may vary depending on differences of manufacturing processes, internal wiring patterns, etc. Therefore, it is requested for users to carry out an evaluation test for each product on an actual system under the same conditions to see its operation.
- Memory register, data area, and stack area values are unstable immediately after power is turned on. They must be initialized before use.

## Ordering Information

### HD404889 Series

Type	Product Name	Model Name	ROM (Words)	RAM (Digits)	Package
Mask ROM	HD404888	HD404888H	8,192	1,344	80-pin plastic QFP (FP-80A)
		HD404888TE			80-pin plastic TQFP (TFP-80C)
	HD4048812	HD4048812H	12,288	80-pin plastic QFP (FP-80A)	
		HD4048812TE		80-pin plastic TQFP (TFP-80C)	
	HD404889	HD404889H	16,384	80-pin plastic QFP (FP-80A)	
		HD404889TE		80-pin plastic TQFP (TFP-80C)	
HCD404889	HCD404889		Chip*2		
ZTAT™	HD4074889	HD4074889H	16,384	80-pin plastic QFP*1 (FP-80A)	
		HD4074889TE		80-pin plastic TQFP*1 (TFP-80C)	

Notes: 1. ZTAT™ chip shipment is not supported.

2. The specifications of shipped chips differ from those of the package product. Please contact our sales staff for details.

# HD404889/HD404899/HD404878/HD404868 Series

## HD404899 Series

Type	Product Name	Model Name	ROM (Words)	RAM (Digits)	Package
Mask ROM	HD404898	HD404898H	8,192	1,344	80-pin plastic QFP (FP-80A)
		HD404898TE			80-pin plastic TQFP (TFP-80C)
	HD4048912	HD4048912H	12,288	80-pin plastic QFP (FP-80A)	
		HD4048912TE		80-pin plastic TQFP (TFP-80C)	
	HD404899	HD404899H	16,384	80-pin plastic QFP (FP-80A)	
		HD404899TE		80-pin plastic TQFP (TFP-80C)	
HCD404899	HCD404899		Chip*2		
ZTAT™	HD4074899	HD4074899H	16,384	80-pin plastic QFP*1 (FP-80A)	
		HD4074899TE		80-pin plastic TQFP*1 (TFP-80C)	

Notes: 1. ZTAT™ chip shipment is not supported.

2. The specifications of shipped chips differ from those of the package product. Please contact our sales staff for details. In planning stage.

## HD404878 Series

Type	Product Name	Model Name	ROM (Words)	RAM (Digits)	Package
Mask ROM	HD404874	HD404874H	4,096	880	80-pin plastic QFP (FP-80A)
		HD404874TE			80-pin plastic TQFP (TFP-80C)
	HD404878	HD404878H	8,192	80-pin plastic QFP (FP-80A)	
		HD404878TE		80-pin plastic TQFP (TFP-80C)	
	HCD404878	HCD404878		Chip*2	
ZTAT™	HD4074889 or HD4074899 is used.*1				

Notes: 1. ZTAT™ chip shipment is not supported.

2. The specifications of shipped chips differ from those of the package product. Please contact our sales staff for details. In planning stage.

---

## HD404889/HD404899/HD404878/HD404868 Series

---

### HD404868 Series

Type	Product Name	Model Name	ROM (Words)	RAM (Digits)	Package
Mask ROM	HD404864	HD404864H	4,096	408	64-pin plastic QFP (FP-64A)
		HD404864S			64-pin plastic DILP (DP-64S)
	HD404868	HD404868H	8,192		64-pin plastic QFP (FP-64A)
		HD404868S			64-pin plastic DILP (DP-64S)
	HCD404868	HCD404868			Chip <sup>*1</sup>
	ZTAT™	HD4074869	HD4074869H	16,384	
HD4074869S			64-pin plastic DILP (DP-64S)		

Note: 1. In planning stage

# HD404889/HD404899/HD404878/HD404868 Series

## List of Functions

Product Name	HD404888	HD4048812	HD404889	HCD404889
ROM (words)	8,192	12,288		16,384
RAM (digit)		1,344		
I/O		46 (max)		
Large-current I/O pins	4 (source, 10 mA max), 8 (sink, 15 mA max)			
LCD segment multiplexed pins		16		
Analog input multiplexed pins		6		
Timer/counter	16-bit timer: 1 (Can also be used as two 8-bit timer), 8-bit timer: 2			
Input capture		8 bit × 1		
Timer output		2 (PWM output possible)		
Event input		2 (edge selection possible)		
Serial interface		1 (8-bit synchronous)		
A/D converter		8 bits × 6 channels		
LCD circuit		Max. 32 seg × 4 com		
Interrupt sources	External	3 (edge selection possible for 1)		
	Internal	6		
Low-power modes		4		
Stop mode		0		
Watch mode		0		
Standby mode		0		
Subactive mode		0		
Module standby		0		
System clock division software switching		0		
Main oscillator	Ceramic oscillation	0		
	Crystal oscillation	0		
Sub-oscillator	Crystal oscillation	0 (32.768kHz)		
Minimum instruction execution time		0.89μs(f <sub>osc</sub> =4.5MHz)		
Operating voltage (V)		1.8 to 5.5		
Package		80-pin plastic QFP (FP-80A)		Chip
		80-pin plastic TQFP (TFP-80C)		
Guaranteed operation temperature(°C)		-20 to +75		+75

# HD404889/HD404899/HD404878/HD404868 Series

Product Name	HD4074889	HD404898	HD4048912	HD404899
ROM (words)	16,384PROM	8,192	12,288	16,384
RAM (digit)		1,344		
I/O		46 (max)		
Large-current I/O pins	4 (source, 10 mA max), 8 (sink, 15 mA max)			
LCD segment multiplexed pins		16		
Analog input multiplexed pins		6		
Timer/counter	16-bit timer: 1 (Can also be used as two 8-bit timer), 8-bit timer: 2			
Input capture		8 bit × 1		
Timer output		2 (PWM output possible)		
Event input		2 (edge selection possible)		
Serial interface		1 (8-bit synchronous)		
A/D converter	8 bits × 6 channels	10 bits × 6 channels		
LCD circuit	Max. 32 seg × 4 com			
Interrupt sources	External	3 (edge selection possible for 1)		
	Internal	6		
Low-power modes		4		
Stop mode		O		
Watch mode		O		
Standby mode		O		
Subactive mode		O		
Module standby		O		
System clock division software switching		O		
Main oscillator	Ceramic oscillation	O		
	Crystal oscillation	O		
Sub-oscillator	Crystal oscillation	O (32.768kHz)		
Minimum instruction execution time		0.89μs(f <sub>osc</sub> =4.5MHz)		
Operating voltage (V)	2.0 to 5.5	1.8 to 5.5		
Package	80-pin plastic QFP (FP-80A) 80-pin plastic TQFP (TFP-80C)			
Guaranteed operation temperature(°C)	-20 to +75			

# HD404889/HD404899/HD404878/HD404868 Series

Product Name	HD40C4899	HD4074899	HD404874	HD404878	
ROM (words)	16,384	16,384PROM	4,096	8,192	
RAM (digit)	1,344		880		
I/O	46 (max)				
Large-current I/O pins	4 (source, 10 mA max), 8 (sink, 15 mA max)				
LCD segment multiplexed pins	16				
Analog input multiplexed pins	6		—		
Timer/counter	16-bit timer: 1 (Can also be used as two 8-bit timer), 8-bit timer: 2				
Input capture	8 bit × 1				
Timer output	2 (PWM output possible)				
Event input	2 (edge selection possible)				
Serial interface	1 (8-bit synchronous)				
A/D converter	10 bits × 6 channels		—		
LCD circuit	Max. 32 seg × 4 com				
Interrupt sources	External	3 (edge selection possible for 1)			
	Internal	6	5		
Low-power modes				4	
Stop mode				O	
Watch mode				O	
Standby mode				O	
Subactive mode				O	
Module standby				O	
System clock division software switching				O	
Main oscillator	Ceramic oscillation				O
	Crystal oscillation				O
Sub-oscillator	Crystal oscillation	O (32.768kHz)			
Minimum instruction execution time	0.89μs(f <sub>OSC</sub> =4.5MHz)				
Operating voltage (V)	1.8 to 5.5	2.0 to 5.5	1.8 to 5.5		
Package	Chip	80-pin plastic QFP (FP-80A)			
		80-pin plastic TQFP (TFP-80C)			
Guaranteed operation temperature(°C)	+75		-20 to +75		

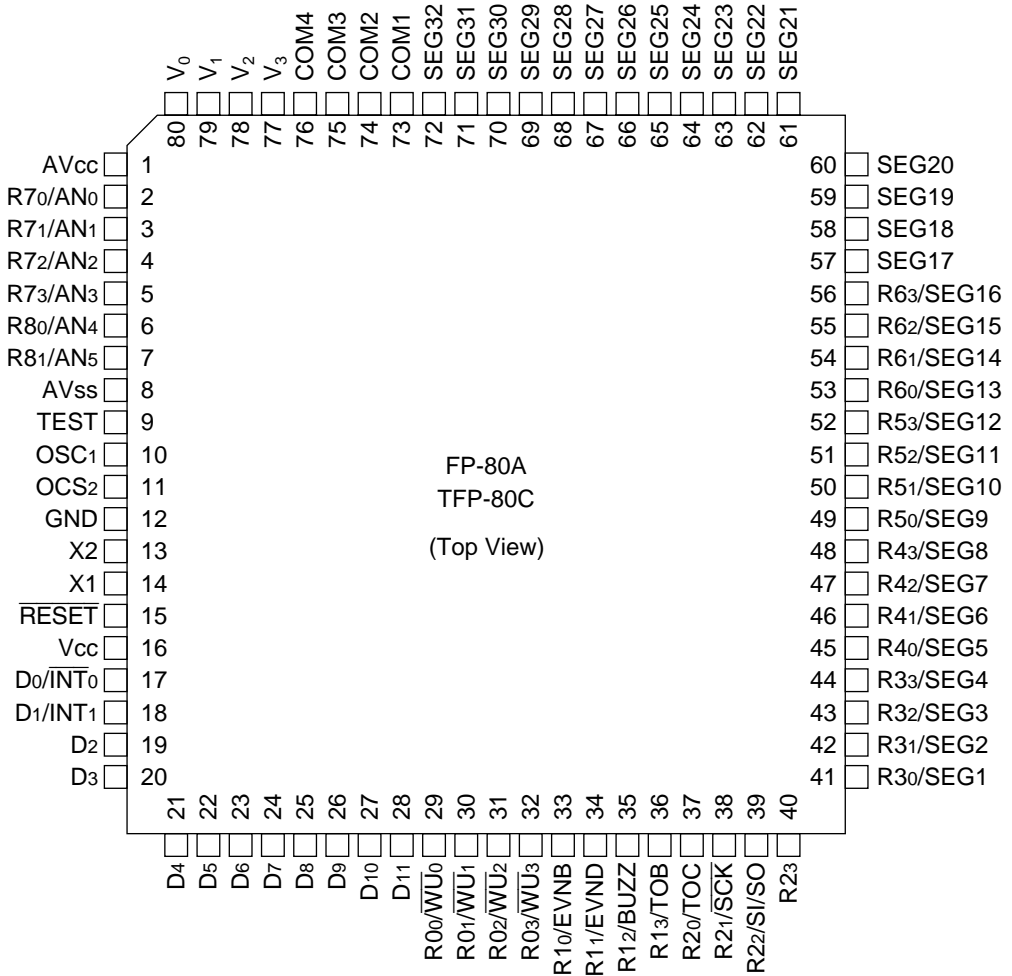
## HD404889/HD404899/HD404878/HD404868 Series

Product Name	HCD404878	HD404864	HD404868	HD4074869
ROM (words)	8,192	4,096	8,192	16,384PROM
RAM (digit)	880	408		
I/O	46 (max)	41 (max)		
Large-current I/O pins	4 (source, 10 mA max), 8 (sink, 15 mA max)	4 (source, 10 mA max), 6 (sink, 15 mA max)		
LCD segment multiplexed pins		16		
Analog input multiplexed pins	—	4		
Timer/counter	16-bit timer: 1 (Can also be used as two 8-bit timer), 8-bit timer: 2	16-bit timer: 1 (Can also be used as two 8-bit timer), 8-bit timer: 1		
Input capture	8 bit × 1	—		
Timer output		2 (PWM output possible)		
Event input	2 (edge selection possible)	1 (edge selection possible)		
Serial interface		1 (8-bit synchronous)		
A/D converter	—	10 bits × 4 channels		
LCD circuit	Max. 32 seg × 4 com	Max. 24 seg × 4 com		
Interrupt sources	External	3 (edge selection possible for 1)		
	Internal	5		
Low-power modes		4		
Stop mode		O		
Watch mode		O		
Standby mode		O		
Subactive mode		O		
Module standby		O		
System clock division software switching		O		
Main oscillator	Ceramic oscillation	O		
	Crystal oscillation	O		
Sub-oscillator	Crystal oscillation	O (32.768kHz)		
Minimum instruction execution time		0.89μs(f <sub>osc</sub> =4.5MHz)		
Operating voltage (V)	1.8 to 5.5			2.0 to 5.5
Package	Chip	64-pin plastic QFP (FP-64A) 64-pin plastic DILP (DP-64S)		
Guaranteed operation temperature(°C)	+75	-20 to +75		

# HD404889/HD404899/HD404878/HD404868 Series

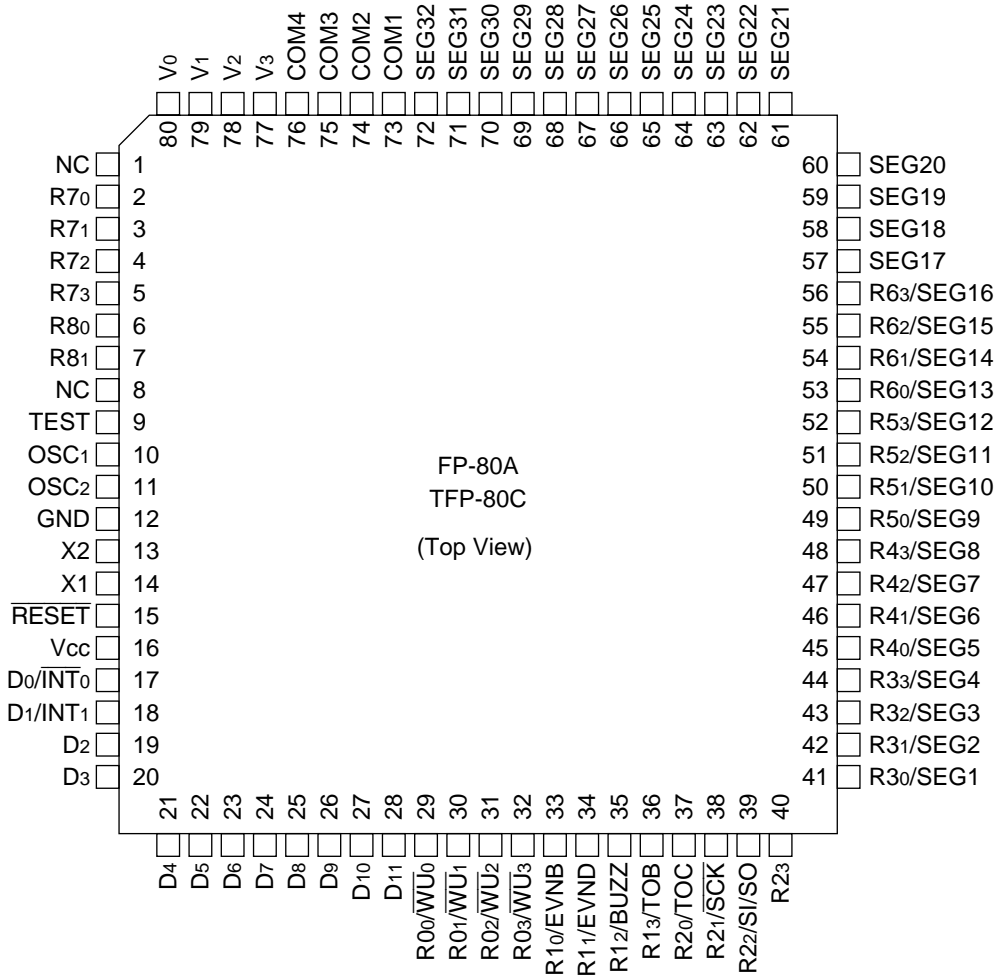
## Pin Arrangement

HD404889/HD404899 Series



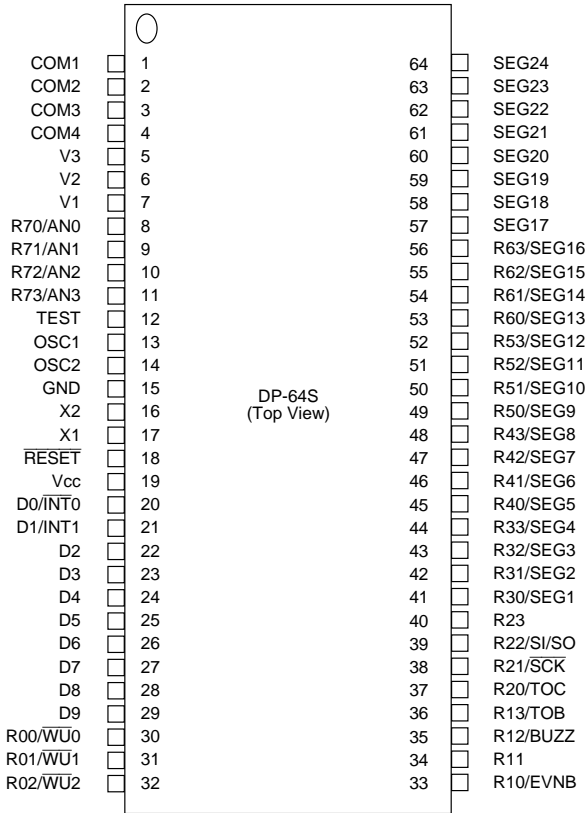
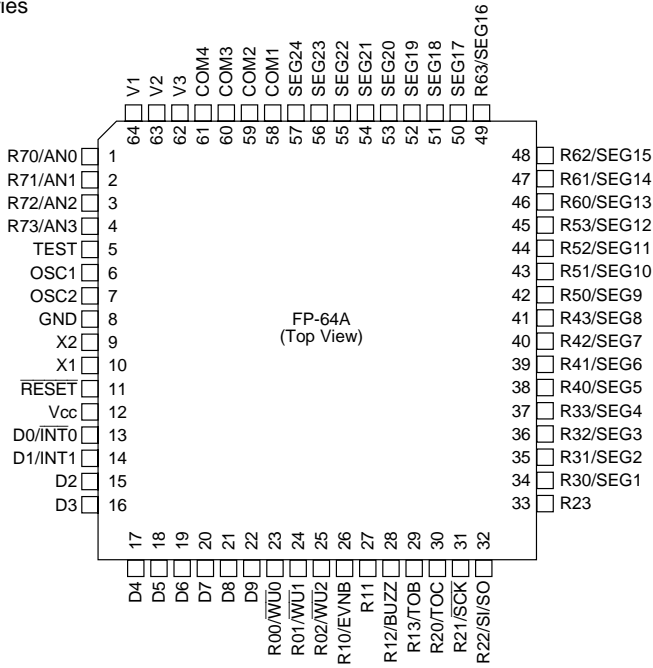
# HD404889/HD404899/HD404878/HD404868 Series

HD404878 Series



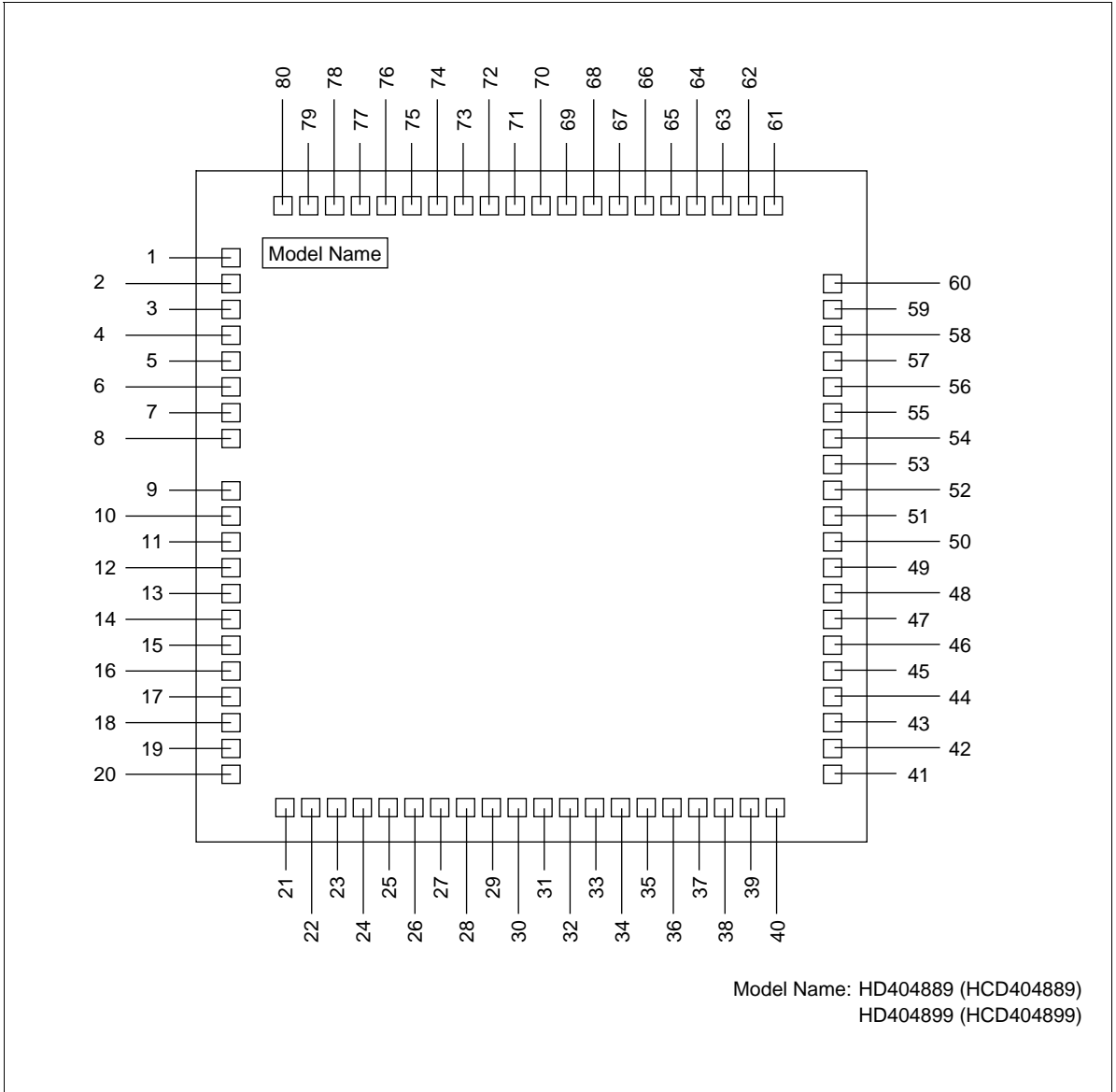
# HD404889/HD404899/HD404878/HD404868 Series

HD404868 Series



**Pad Arrangement**

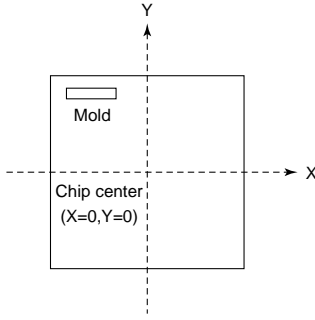
HCD404889, HCD404899



# HD404889/HD404899/HD404878/HD404868 Series

## Pad Coordinates

HCD404889, HCD404899

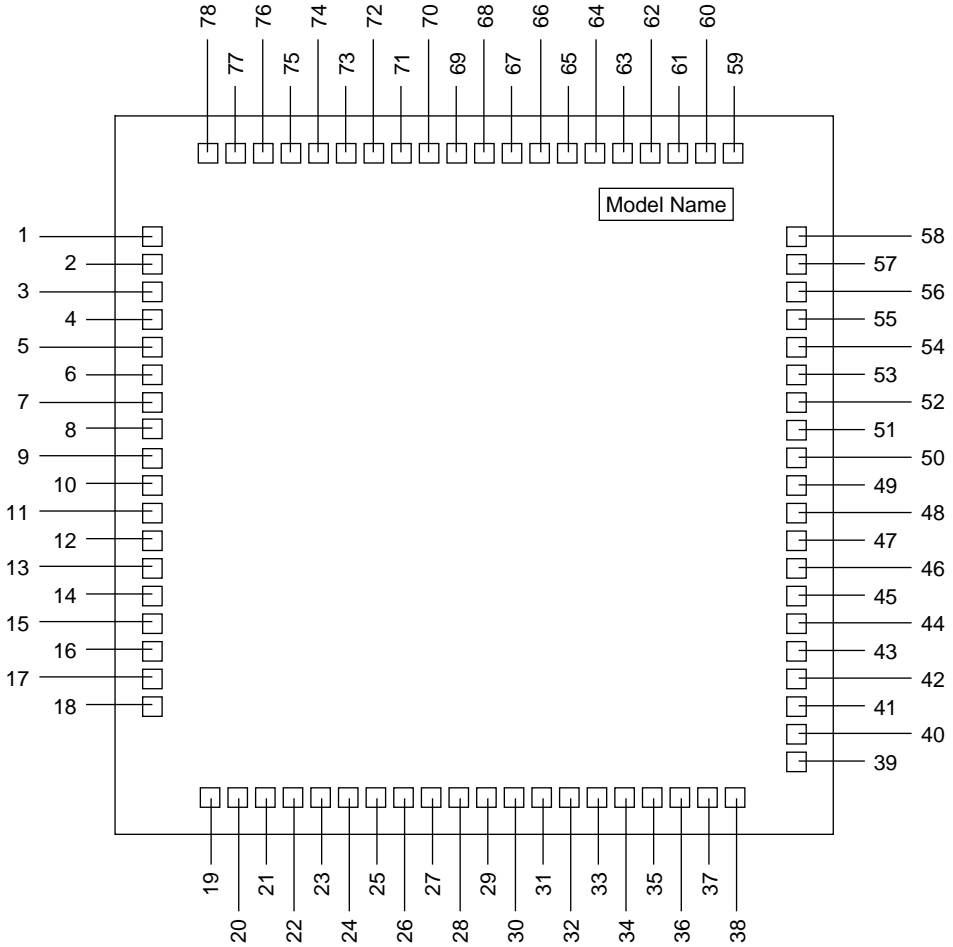


Chip size (X × Y): 4.63 × 4.77 (mm)  
 Coordinates: Pad center  
 Home point position: Chip center  
 Pad size (X × Y): 90 × 90 (μm)  
 Chip thickness: 280 (μm)

Pad No.	Pad name	Coordinates		Pad No.	Pad name	Coordinates	
		X (μm)	Y (μm)			X (μm)	Y (μm)
1	AV <sub>CC</sub>	-2129	1779	41	R30/SEG1	2129	-1787
2	R70/AN0	-2129	1589	42	R31/SEG2	2129	-1616
3	R71/AN1	-2129	1417	43	R32/SEG3	2129	-1445
4	R72/AN2	-2129	1246	44	R33/SEG4	2129	-1273
5	R73/AN3	-2129	1074	45	R40/SEG5	2129	-1102
6	R80/AN4	-2129	903	46	R41/SEG6	2129	-973
7	R81/AN5	-2129	732	47	R42/SEG7	2129	-759
8	AV <sub>SS</sub>	-2129	506	48	R43/SEG8	2129	-588
9	TEST	-2129	103	49	R50/SEG9	2129	-417
10	OSC1	-2129	-68	50	R51/SE10	2129	-245
11	OSC2	-2129	-240	51	R52/SEG11	2129	-74
12	GND	-2129	-434	52	R53/SEG12	2129	98
13	X2	-2129	-605	53	R60/SEG13	2129	269
14	X1	-2129	-776	54	R61/SEG14	2129	440
15	RESETN	-2129	-948	55	R62/SEG15	2129	612
16	V <sub>CC</sub>	-2129	-1119	56	R63/SEG16	2129	783
17	D0/INT0N	-2129	-1290	57	SEG17	2129	954
18	D1/INT1	-2129	-1462	58	SEG18	2129	1126
19	D2	-2129	-1633	59	SEG19	2129	1297
20	D3	-2129	-1804	60	SEG20	2129	1477
21	D4	-1677	-2199	61	SEG21	1588	2199
22	D5	-1506	-2199	62	SEG22	1407	2199
23	D6	-1335	-2199	63	SEG23	1236	2199
24	D7	-1163	-2199	64	SEG24	1064	2199
25	D8	-992	-2199	65	SEG25	893	2199
26	D9	-821	-2199	66	SEG26	722	2199
27	D10	-649	-2199	67	SEG27	550	2199
28	D11	-478	-2199	68	SEG28	379	2199
29	R00/WU0N	-307	-2199	69	SEG29	208	2199
30	R01/WU1N	-135	-2199	70	SEG30	36	2199
31	R02/WU2N	36	-2199	71	SEG31	-135	2199
32	R03/WU3N	208	-2199	72	SEG32	-307	2199
33	R10/EVNB	379	-2199	73	COM1	-478	2199
34	R11/EVND	550	-2199	74	COM2	-649	2199
35	R12/BUZZ	722	-2199	75	COM3	-821	2199
36	R13/TOB	893	-2199	76	COM4	-992	2199
37	R20/TOC	1064	-2199	77	V3	-1163	2199
38	R21/SCKN	1236	-2199	78	V2	-1335	2199
39	R22/SI/SO	1407	-2199	79	V1	-1506	2199
40	R23	1588	-2199	80	V0	-1677	2199

Pad Arrangement

HCD404878

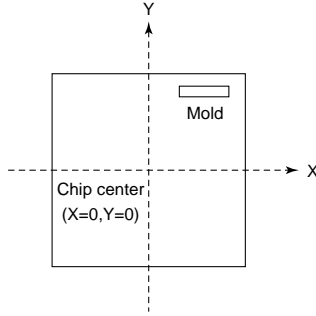


Model Name: HD404878 (HCD404878)

# HD404889/HD404899/HD404878/HD404868 Series

## Pad Coordinates

HCD404878



Chip size (X × Y): 4.13 × 4.26 (mm)  
 Coordinates: Pad center  
 Home point position: Chip center  
 Pad size (X × Y): 90 × 90 (μm)  
 Chip thickness: 280 (μm)

Pad No.	Pad name	Coordinates		Pad No.	Pad name	Coordinates	
		X (μm)	Y (μm)			X (μm)	Y (μm)
1	R70	-1879	1446	40	R31/SEG2	1879	-1405
2	R71	-1879	1280	41	R32/SEG3	1879	-1239
3	R72	-1879	1114	42	R33/SEG4	1879	-1072
4	R73	-1879	948	43	R40/SEG5	1879	-906
5	R80	-1879	781	44	R41/SEG6	1879	-740
6	R81	-1879	615	45	R42/SEG7	1879	-573
7	TEST	-1879	449	46	R43/SEG8	1879	-407
8	OSC1	-1879	282	47	R50/SEG9	1879	-241
9	OSC2	-1879	116	48	R51/SE10	1879	-74
10	GND	-1879	-73	49	R52/SEG11	1879	92
11	X2	-1879	-239	50	R53/SEG12	1879	258
12	X1	-1879	-406	51	R60/SEG13	1879	425
13	RESETN	-1879	-572	52	R61/SEG14	1879	591
14	V <sub>CC</sub>	-1879	-738	53	R62/SEG15	1879	757
15	D0/INT0N	-1879	-905	54	R63/SEG16	1879	924
16	D1/INT1	-1879	-1071	55	SEG17	1879	1087
17	D2	-1879	-1237	56	SEG18	1879	1246
18	D3	-1879	-1404	57	SEG19	1879	1405
19	D4	-1654	-1943	58	SEG20	1879	1564
20	D5	-1488	-1943	59	SEG21	1509	1943
21	D6	-1322	-1943	60	SEG22	1351	1943
22	D7	-1155	-1943	61	SEG23	1192	1943
23	D8	-989	-1943	62	SEG24	1033	1943
24	D9	-823	-1943	63	SEG25	874	1943
25	D10	-656	-1943	64	SEG26	716	1943
26	D11	-490	-1943	65	SEG27	557	1943
27	R00/WU0N	-324	-1943	66	SEG28	398	1943
28	R01/WU1N	-158	-1943	67	SEG29	239	1943
29	R02/WU2N	9	-1943	68	SEG30	81	1943
30	R03/WU3N	175	-1943	69	SEG31	-78	1943
31	R10/EVNB	341	-1943	70	SEG32	-237	1943
32	R11/EVND	508	-1943	71	COM1	-411	1943
33	R12/BUZZ	674	-1943	72	COM2	-570	1943
34	R13/TOB	840	-1943	73	COM3	-728	1943
35	R20/TOC	1007	-1943	74	COM4	-887	1943
36	R21/SCKN	1173	-1943	75	V3	-1038	1943
37	R22/Si/SO	1339	-1943	76	V2	-1194	1943
38	R23	1506	-1943	77	V1	-1351	1943
39	R30/SEG1	1879	-1571	78	V0	-1507	1943

## Pin Description

HD404889/HD404899/HD404878 Series

Item	Symbol	Pin Number		Function
		FP-80A TFP-80C	I/O	
Power supply	V <sub>CC</sub>	16	—	Apply the power supply voltage to this pin.
	GND	12	—	Connect to ground.
Test	TEST	9	Input	Not for use by the user application. Connect to GND potential.
Reset	RESET	15	Input	Used to reset the MCU.
Oscillation	OSC <sub>1</sub>	10	Input	Internal oscillator input/output pins. Connect a ceramic resonator, crystal resonator, or external oscillator circuit.
	OSC <sub>2</sub>	11	Output	
	X1	14	Input	Realtime clock oscillator input/output pins. Connect a 32.768 kHz crystal. If 32.768 kHz crystal oscillation is not used, fix the ×1 pin to V <sub>CC</sub> and leave the ×2 pin open.
	X2	13	Output	
Port	D <sub>0</sub> –D <sub>11</sub>	17–28	I/O	I/O pins addressed bit by bit. D <sub>0</sub> to D <sub>3</sub> are large-current source pins (max. 10 mA), and D <sub>4</sub> to D <sub>11</sub> are large-current sink pins (max. 15 mA).
	R <sub>0</sub> –R <sub>6</sub> <sub>3</sub> R <sub>7</sub> –R <sub>8</sub> <sub>1</sub>	29–56, 2–7	I/O	I/O pins, addressed in 4-bit units.
Interrupt	INT <sub>0</sub> , INT <sub>1</sub>	17, 18	Input	External interrupt input pins
Wakeup	WU <sub>0</sub> –WU <sub>3</sub>	29–32	Input	Input pins used for transition from stop mode to active mode.
Serial interface	SCK	38	I/O	Serial interface clock I/O pin
	SI	39	Input	Serial interface receive data input pin
	SO	39	Output	Serial interface transmit data output pin
Timer	TOB, TOC	36, 37	Output	Timer output pins
	EVNB, EVND	33, 34	Input	Event count input pins
LCD	V <sub>0</sub> –V <sub>3</sub>	80–77	—	LCD driver power supply pins. The on-chip power supply dividing resistor can be disconnected by software. Power supply conditions are: V <sub>CC</sub> ≥ V <sub>1</sub> ≥ V <sub>2</sub> ≥ V <sub>3</sub> ≥ GND.
	COM1–COM4	73–76	Output	LCD common signal pins
	SEG1–SEG32	41–72	Output	LCD segment signal pins
A/D converter*1	AV <sub>CC</sub>	1	—	A/D converter power supply pin. Connect as close as possible to the V <sub>CC</sub> pin so as to be at the same potential as V <sub>CC</sub> .
	AV <sub>SS</sub>	8	—	Ground pin for AV <sub>CC</sub> . Connect as close as possible to the GND pin so as to be at the same potential as GND.
	AN <sub>0</sub> –AN <sub>5</sub>	2–7	Input	A/D converter analog input pins
Buzzer output	BUZZ	35	Output	Timer overflow toggle output or divided system clock output pin
Other	NC	1, 8 <sup>2</sup>	—	Connect to ground potential.

Notes: 1. Applies to HD404889 and HD404899 series.

2. Applies to HD404878 series.

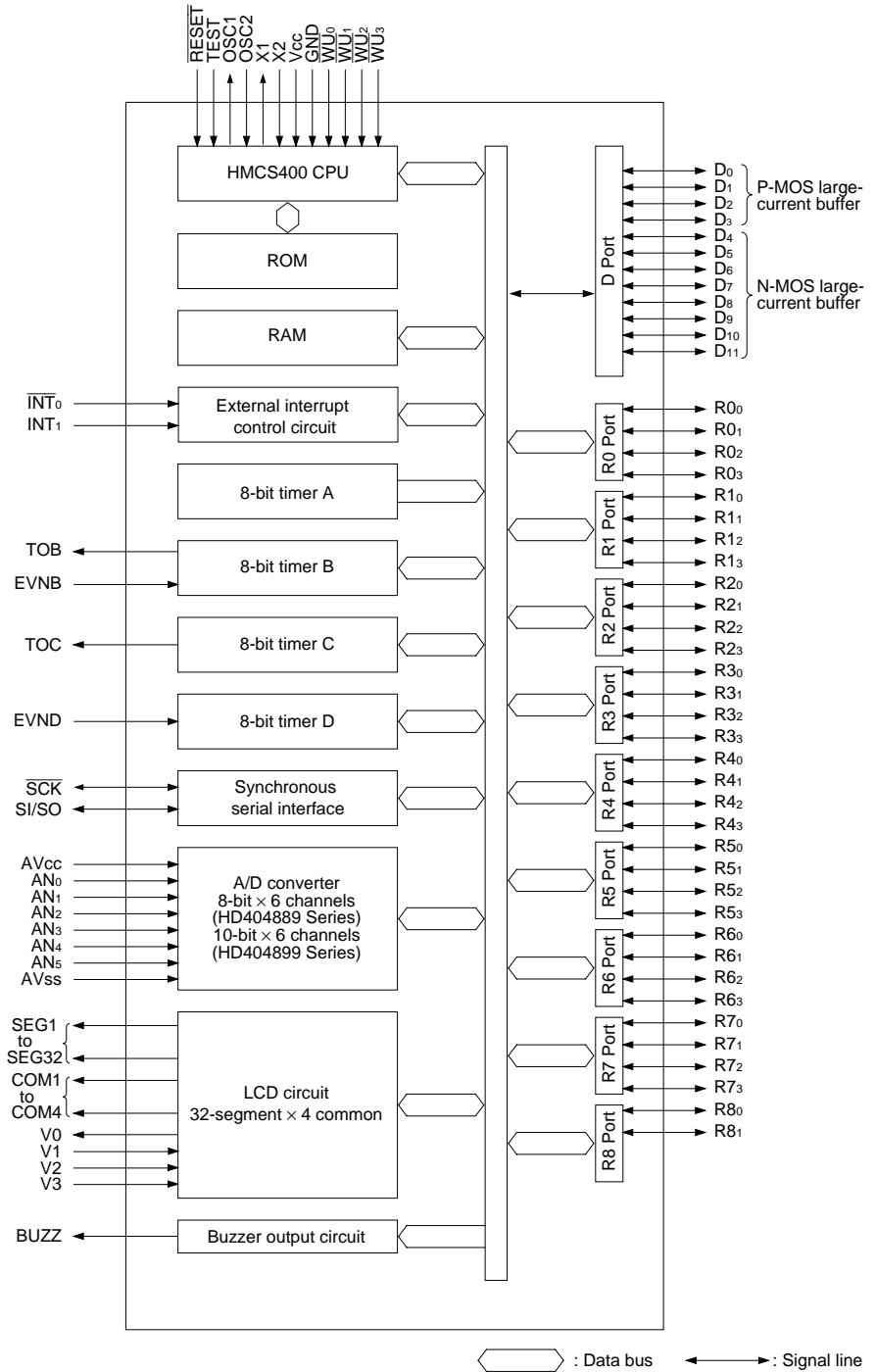
# HD404889/HD404899/HD404878/HD404868 Series

## HD404868 Series

Item	Symbol	Pin Number		I/O	Function
		FP-64A	DP-64S		
Power supply	$V_{CC}$	12	19	—	Apply the power supply voltage to this pin.
	GND	8	15	—	Connect to ground.
Test	TEST	5	12	Input	Not for use by the user application. Connect to GND potential.
Reset	$\overline{RESET}$	11	18	Input	Used to reset the MCU.
Oscillation	OSC <sub>1</sub>	6	13	Input	Internal oscillator input/output pins. Connect a ceramic resonator, crystal resonator, or external oscillator circuit.
	OSC <sub>2</sub>	7	14	Output	
	X1	10	17	Input	Realtime clock oscillator input/output pins. Connect a 32.768 kHz crystal. If 32.768 kHz crystal oscillation is not used, fix the ×1 pin to $V_{CC}$ and leave the ×2 pin open.
	X2	9	16	Output	
Port	D <sub>0</sub> –D <sub>9</sub>	13–22	20–29	I/O	I/O pins addressed bit by bit. D <sub>0</sub> to D <sub>3</sub> are large-current source pins (max. 10 mA), and D <sub>4</sub> to D <sub>9</sub> are large-current sink pins (max. 15 mA).
	R <sub>0</sub> –R <sub>0</sub> <sub>2</sub>	23–25	30–32	I/O	I/O pins, addressed in 4-bit units.
	R <sub>1</sub> –R <sub>6</sub> <sub>3</sub>	26–49	33–56	I/O	
R <sub>7</sub> –R <sub>7</sub> <sub>3</sub>	1–4	8–11	I/O		
Interrupt	$\overline{INT}_0, INT_1$	13, 14	20, 21	Input	External interrupt input pins
Wakeup	$\overline{WU}_0, \overline{WU}_2$	23–25	30–32	Input	Input pins used for transition from stop mode to active mode.
Serial interface	$\overline{SCK}$	31	38	I/O	Serial interface clock I/O pin
	SI	32	39	Input	Serial interface receive data input pin
	SO	32	39	Output	Serial interface transmit data output pin
Timer	TOB, TOC	29, 30	36, 37	Output	Timer output pins
	EVNB	26	33	Input	Event count input pins
LCD	V <sub>1</sub> –V <sub>3</sub>	64–62	7–5	—	LCD driver power supply pins. The on-chip power supply dividing resistor can be disconnected by software. Power supply conditions are: $V_{CC} \geq V_1 \geq V_2 \geq V_3 \geq GND$ .
	COM1–COM4	58–61	1–4	Output	LCD common signal pins
	SEG1–SEG24	34–57	41–64	Output	LCD segment signal pins
A/D converter	AN <sub>0</sub> –AN <sub>3</sub>	1–4	8–11	Input	A/D converter analog input pins
Buzzer output	BUZZ	28	35	Output	Timer overflow toggle output or divided system clock output pin

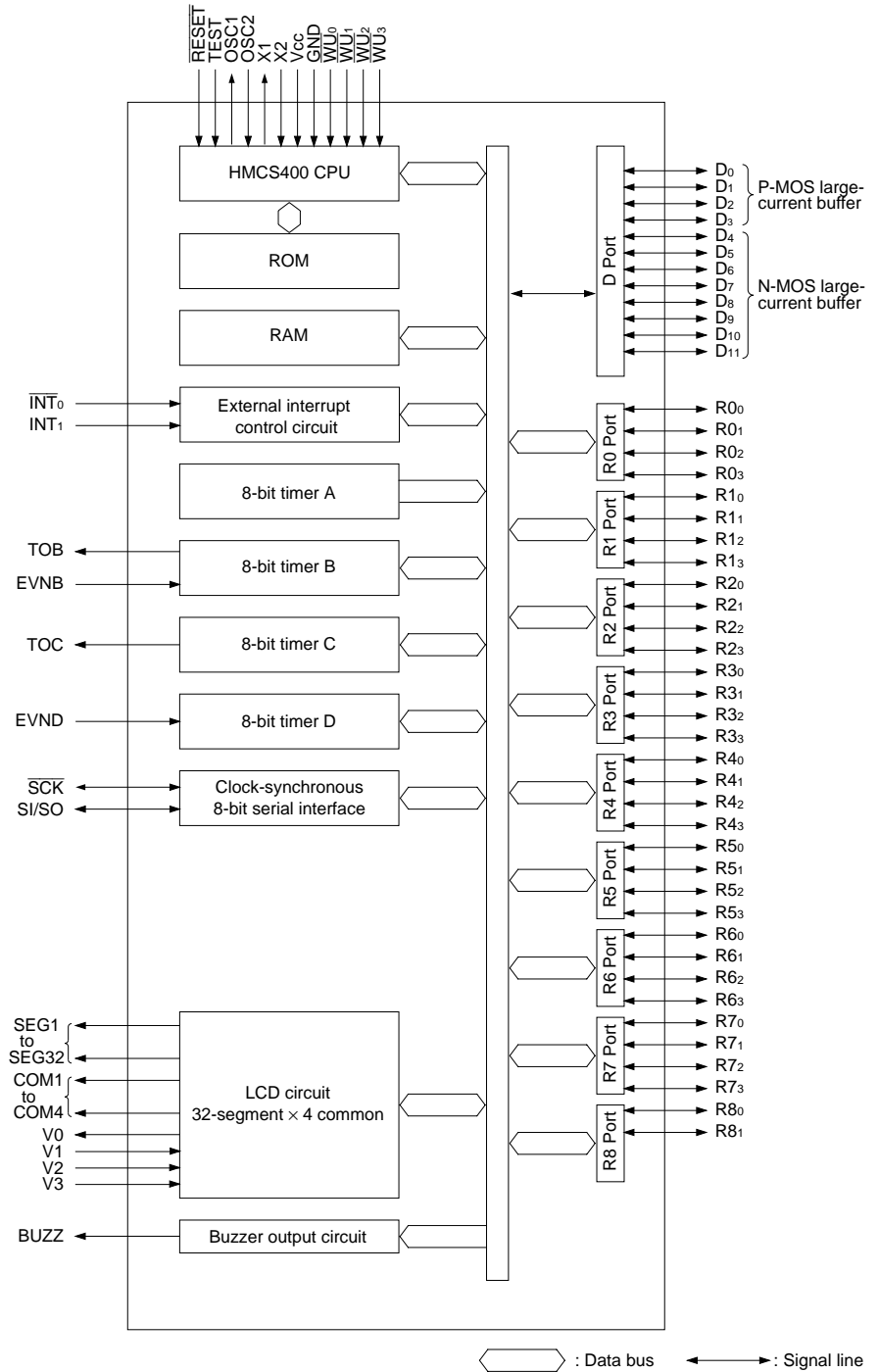
Block DiagramG

HD404889/HD404899 Series

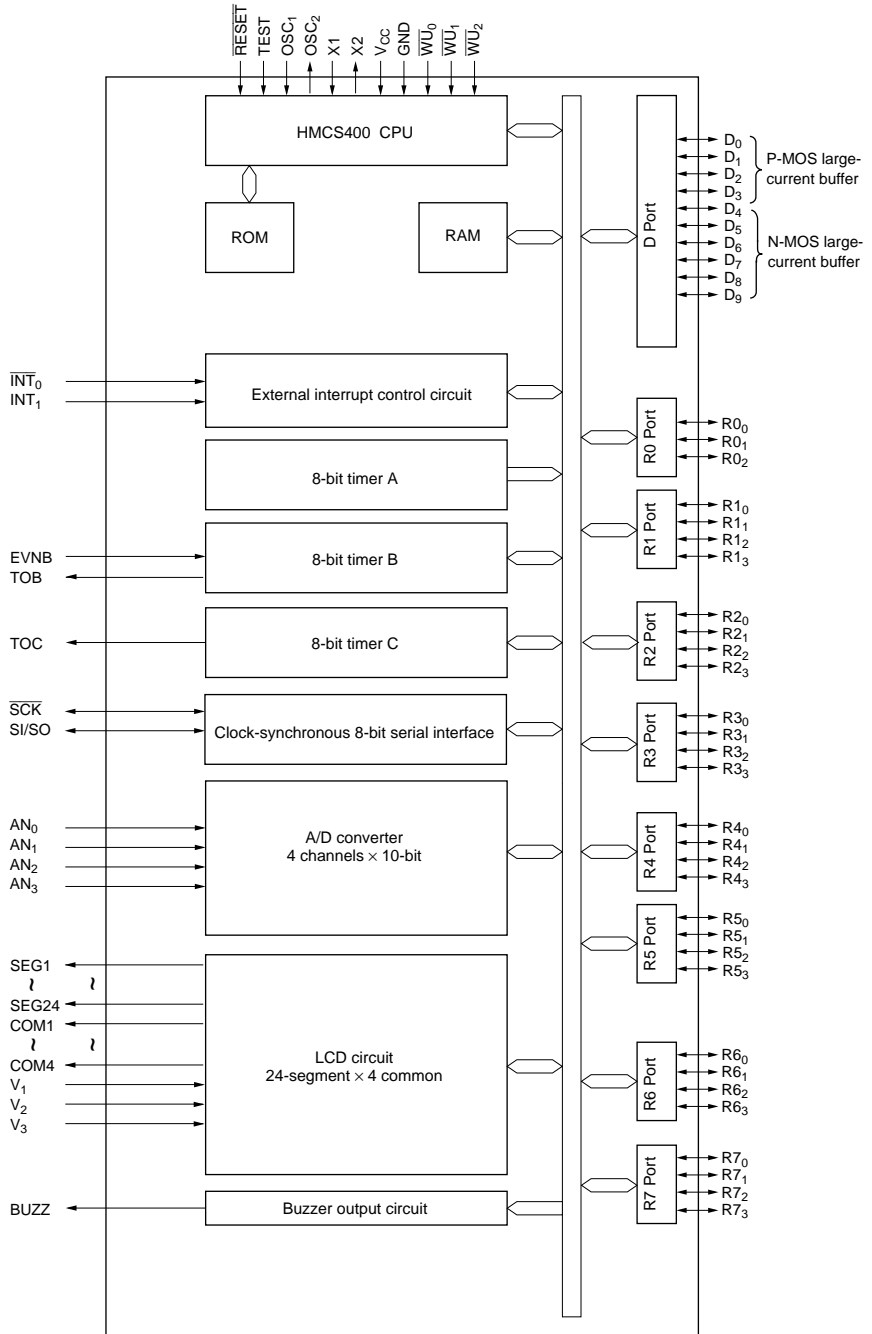


# HD404889/HD404899/HD404878/HD404868 Series

HD404878 Series



## HD404868 Series



## Memory Map

### ROM Memory Map

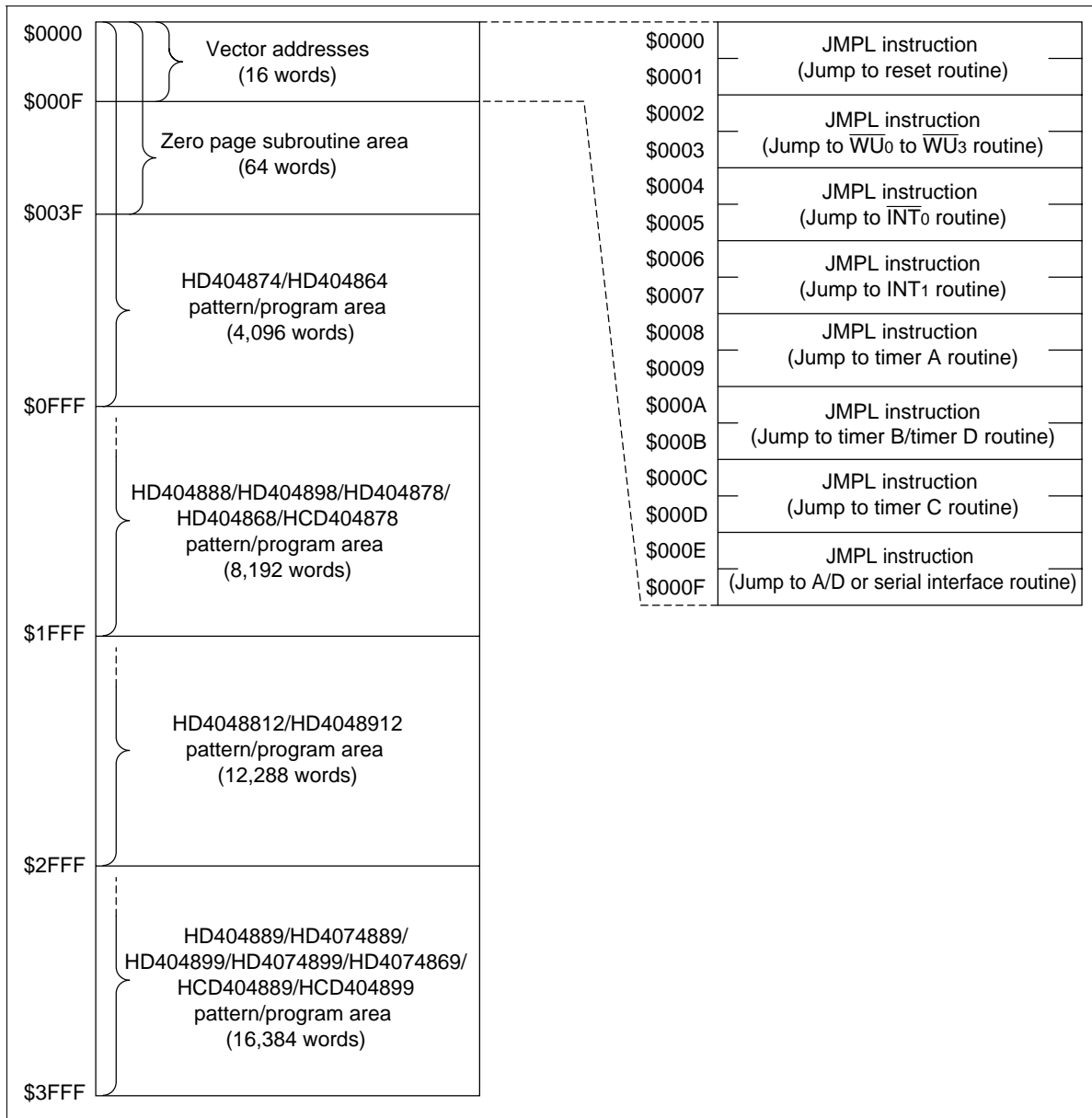
The ROM memory map is shown in figure 1 and is described below.

**Vector address area** (\$0000 to \$000F): When an MCU reset or interrupt handling is performed, the program is executed from the vector address. A JMPL instruction should be used to branch to the start address of the reset routine or the interrupt routine.

**Zero page subroutine area** (\$0000 to \$003F): A branch can be made to a subroutine in the area \$0000 to \$003F with the CAL instruction.

**Pattern area** (\$0000 to \$0FFF): ROM data in the area \$0000 to \$0FFF can be referenced as pattern data with the P instruction.

**Program area** (\$0000 to \$0FFF(HD404874, HD404864)), (\$0000 to \$1FFF (HD404888, HD404898, HD404878, HD404868, HCD404878)), (\$0000 to \$2FFF (HD4048812, HD4048912)), (\$0000 to \$3FFF (HD404889, HD404899, HCD404889, HCD404899, HD4074899, HD4074889, HD4074869))



**Figure 1 ROM Memory Map**

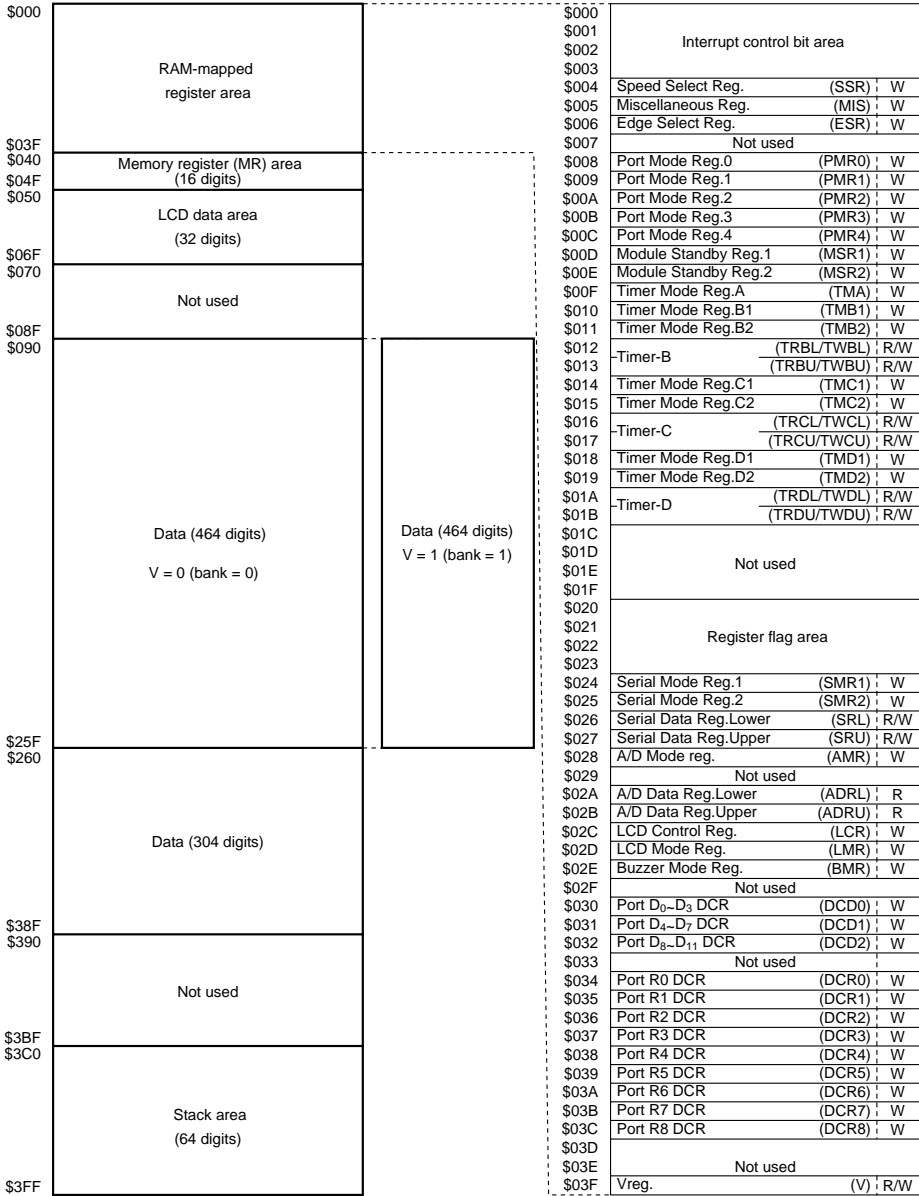
**RAM Memory Map**

The MCU has on-chip RAM comprising a memory register area, LCD data area, data area, and stack area. In addition to these areas, an interrupt control bit area, special register area, and register flag area are mapped onto RAM memory space as a RAM-mapped register area. The RAM memory map is shown in figure 2 and described below.

**Memory register, LCD data area, data area, and stack area values are unstable immediately after power is turned on. They must be initialized before use.**

# HD404889/HD404899/HD404878/HD404868 Series

## HD404889 Series



Notes: R : Read  
W : Write

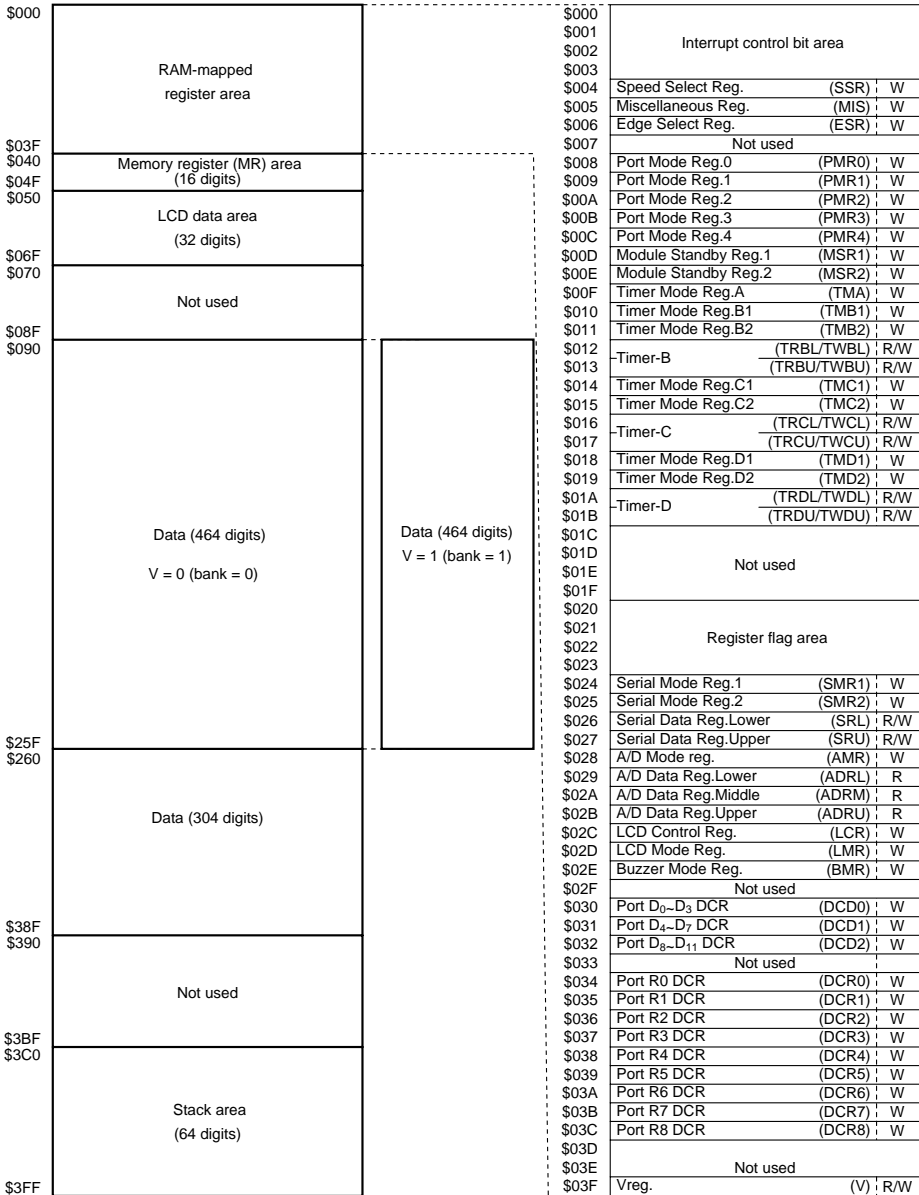
R/W : Read/Write

\*Two registers are mapped onto the same address (\$012, \$013, \$016, \$017, \$01A, \$01B).

\$012	Timer Read Reg.B Lower (TRBL)	R	Timer Write Reg.B Lower (TWBL)	W
\$013	Timer Read Reg.B Upper (TRBU)	R	Timer Write Reg.B Upper (TWBU)	W
\$016	Timer Read Reg.C Lower (TRCL)	R	Timer Write Reg.C Lower (TWCL)	W
\$017	Timer Read Reg.C Upper (TRCU)	R	Timer Write Reg.C Upper (TWCU)	W
\$01A	Timer Read Reg.D Lower (TRDL)	R	Timer Write Reg.D Lower (TWDL)	W
\$01B	Timer Read Reg.D Upper (TRDU)	R	Timer Write Reg.D Upper (TWDU)	W

Figure 2 RAM Memory Map

## HD404899 Series



Notes: R : Read  
W : Write  
R/W : Read/Write

\*Two registers are mapped onto the same address (\$012, \$013, \$016, \$017, \$01A, \$01B).

\$012	Timer Read Reg.B Lower (TRBL) ; R	Timer Write Reg.B Lower (TWBL) ; W	
\$013	Timer Read Reg.B Upper (TRBU) ; R	Timer Write Reg.B Upper (TWBU) ; W	
\$016	Timer Read Reg.C Lower (TRCL) ; R	Timer Write Reg.C Lower (TWCL) ; W	
\$017	Timer Read Reg.C Upper (TRCU) ; R	Timer Write Reg.C Upper (TWCU) ; W	
\$01A	Timer Read Reg.D Lower (TRDL) ; R	Timer Write Reg.D Lower (TWDL) ; W	
\$01B	Timer Read Reg.D Upper (TRDU) ; R	Timer Write Reg.D Upper (TWDU) ; W	

**Figure 2 RAM Memory Map (cont)**

# HD404889/HD404899/HD404878/HD404868 Series

## HD404878 Series

\$000	RAM-mapped register area	\$000	Interrupt control bit area	
\$03F		Memory register (MR) area (16 digits)	\$001	
\$040			\$002	
\$04F	\$003			
\$050	LCD data area (32 digits)	\$004	Speed Select Reg. (SSR) ; W	
\$06F		\$005	Miscellaneous Reg. (MIS) ; W	
\$070		\$006	Edge Select Reg. (ESR) ; W	
\$08F	Not used	\$007	Not used	
\$090		\$008	Port Mode Reg.0 (PMR0) ; W	
		\$009	Port Mode Reg.1 (PMR1) ; W	
	Data (768 digits)	\$00A	Port Mode Reg.2 (PMR2) ; W	
		\$00B	Port Mode Reg.3 (PMR3) ; W	
		\$00C	Port Mode Reg.4 (PMR4) ; W	
	Not used	\$00D	Module Standby Reg.1 (MSR1) ; W	
		\$00E	Module Standby Reg.2 (MSR2) ; W	
		\$00F	Timer Mode Reg.A (TMA) ; W	
	Not used	\$010	Timer Mode Reg.B1 (TMB1) ; W	
		\$011	Timer Mode Reg.B2 (TMB2) ; W	
		\$012	Timer-B (TRBL/TWBL) ; R/W	
	Not used	\$013	Timer-B (TRBU/TWBU) ; R/W	
		\$014	Timer Mode Reg.C1 (TMC1) ; W	
		\$015	Timer Mode Reg.C2 (TMC2) ; W	
	Not used	\$016	Timer-C (TRCL/TWCL) ; R/W	
		\$017	Timer-C (TRCU/TWCU) ; R/W	
		\$018	Timer Mode Reg.D1 (TMD1) ; W	
	Not used	\$019	Timer Mode Reg.D2 (TMD2) ; W	
		\$01A	Timer-D (TRDL/TWDL) ; R/W	
		\$01B	Timer-D (TRDU/TWDU) ; R/W	
	Not used	\$01C		
		\$01D		
		\$01E		
	Not used	\$01F		
		\$020		
		\$021		
	Not used	\$022	Register flag area	
		\$023		
		\$024	Serial Mode Reg.1 (SMR1) ; W	
	Not used	\$025	Serial Mode Reg.2 (SMR2) ; W	
		\$026	Serial Data Reg.Lower (SRL) ; R/W	
		\$027	Serial Data Reg.Upper (SRU) ; R/W	
	Not used	\$028		
		\$029		
		\$02A		
	Not used	\$02B		
		\$02C	LCD Control Reg. (LCR) ; W	
		\$02D	LCD Mode Reg. (LMR) ; W	
	Not used	\$02E	Buzzer Mode Reg. (BMR) ; W	
		\$02F	Not used	
		\$030	Port D <sub>0</sub> -D <sub>3</sub> DCR (DCD0) ; W	
\$38F	Not used	\$031	Port D <sub>4</sub> -D <sub>7</sub> DCR (DCD1) ; W	
\$390		\$032	Port D <sub>8</sub> -D <sub>11</sub> DCR (DCD2) ; W	
		\$033	Not used	
	Not used	\$034	Port R0 DCR (DCR0) ; W	
		\$035	Port R1 DCR (DCR1) ; W	
		\$036	Port R2 DCR (DCR2) ; W	
	Not used	\$037	Port R3 DCR (DCR3) ; W	
		\$038	Port R4 DCR (DCR4) ; W	
		\$039	Port R5 DCR (DCR5) ; W	
\$3BF	Stack area (64 digits)	\$03A	Port R6 DCR (DCR6) ; W	
\$3C0		\$03B	Port R7 DCR (DCR7) ; W	
		\$03C	Port R8 DCR (DCR8) ; W	
	Not used	\$03D		
		\$03E		
\$3FF		\$03F		

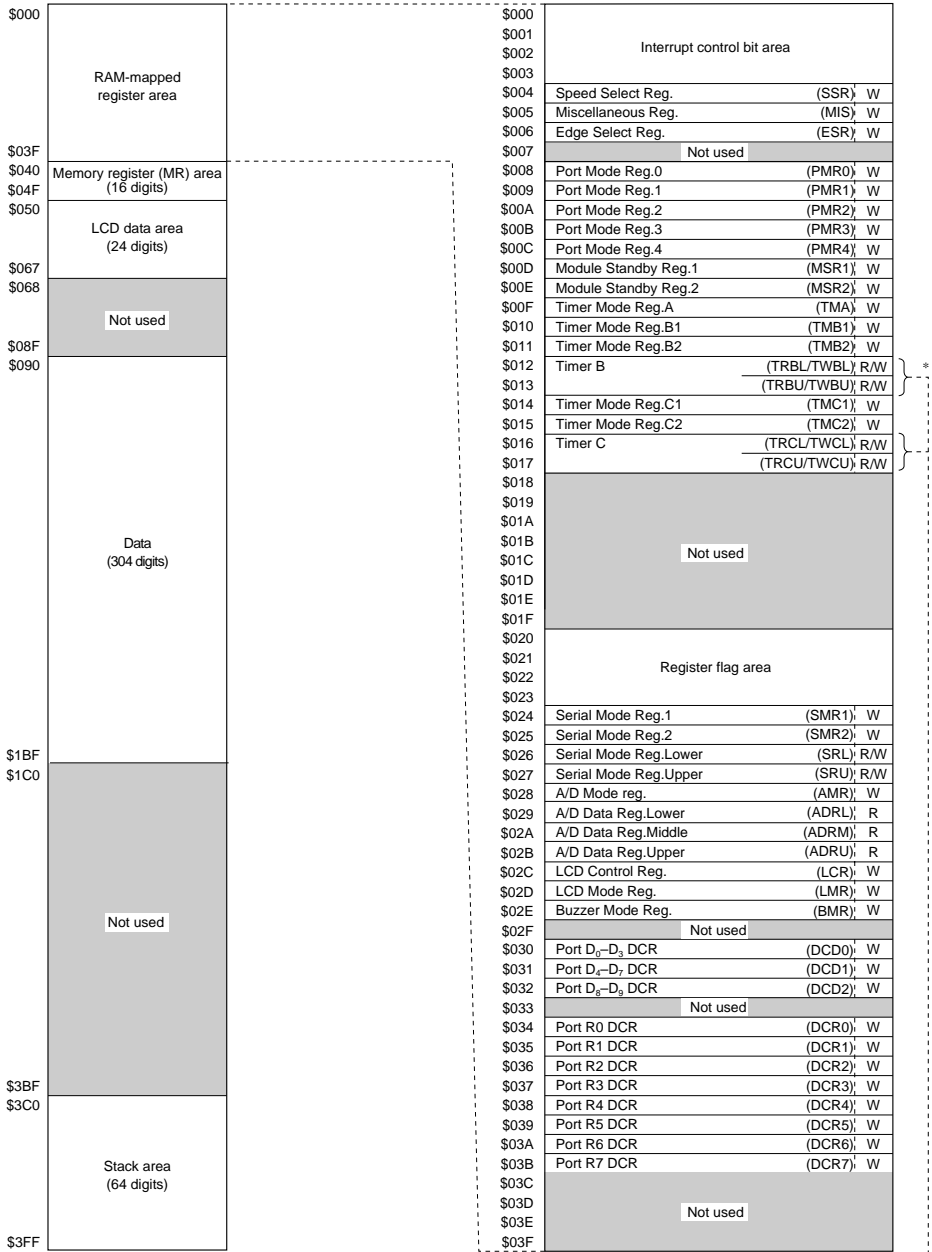
Notes: R : Read  
W : Write  
R/W : Read/Write

\*Two registers are mapped onto the same address (\$012, \$013, \$016, \$017, \$01A, \$01B).

\$012	Timer Read Reg.B Lower (TRBL) ; R	Timer Write Reg.B Lower (TWBL) ; W
\$013	Timer Read Reg.B Upper (TRBU) ; R	Timer Write Reg.B Upper (TWBU) ; W
\$016	Timer Read Reg.C Lower (TRCL) ; R	Timer Write Reg.C Lower (TWCL) ; W
\$017	Timer Read Reg.C Upper (TRCU) ; R	Timer Write Reg.C Upper (TWCU) ; W
\$01A	Timer Read Reg.D Lower (TRDL) ; R	Timer Write Reg.D Lower (TWDL) ; W
\$01B	Timer Read Reg.D Upper (TRDU) ; R	Timer Write Reg.D Upper (TWDU) ; W

Figure 2 RAM Memory Map (cont)

## HD404868 Series



Notes: R : Read  
W : Write  
R/W: Read/Write  
\*Two registers are mapped onto the same address (\$012, \$013, \$016, \$017).

\$012	Timer Read Reg.B Lower (TRBL)	R	Timer Write Reg.B Lower (TWBL)	W
\$013	Timer Read Reg.B Upper (TRBU)	R	Timer Write Reg.B Upper (TWBU)	W
\$016	Timer Read Reg.C Lower (TRCL)	R	Timer Write Reg.C Lower (TWCL)	W
\$017	Timer Read Reg.C Upper (TRCU)	R	Timer Write Reg.C Upper (TWCU)	W

**Figure 2 RAM Memory Map (cont)**

### RAM-mapped register area (\$000 to \$03F):

- Interrupt control bit area (\$000 to \$003)

This area consists of bits used for interrupt control. Its configuration is shown in figure 3. Individual bits can only be accessed by RAM bit manipulation instructions (SEM/SEMD, REM/REMD, TM/TMD). There are restrictions on access to certain bits. The individual bits and instruction restrictions are shown in figure 4.

- Special register area (\$004 to \$01F, \$024 to \$03F)

This area comprises mode registers and data registers for external interrupts, the serial interface, timers, LCD, A/D converter, etc., and I/O pin data control registers. Its configuration is shown in figures 2 and 5. These registers are of three kinds: write-only (W), read-only (R), and read/write (R/W). The SEM/SEMD and REM/REMD instructions can be used on the LCD control register (LCR: \$02C) and the third bit of buzzer mode register (BMR3: \$02E, 3), but RAM bit manipulation instructions cannot be used on the other registers.

- Register flag area (\$020 to \$023)

This area consists of the DTON and WDON flags and interrupt control bits. Its configuration is shown in figure 3. Individual bits can only be accessed by RAM bit manipulation instructions (SEM/SEMD, REM/REMD, TM/TMD). There are restrictions on access to certain bits. The individual bits and instruction restrictions are shown in figure 4.

### Memory register (MR) area (\$040 to \$04F):

In this data area, the 16 memory register digits (MR(0) to MR(15)) can also be accessed by the register-register instructions LAMR and XMRA. The configuration of this area is shown in figure 6.

### LCD data area: \$050 to \$06F (HD404889/HD404899/HD404878 Series) \$050 to \$067 (HD404868 Series)

This 32-digit data area stores data to be displayed on an LCD. Data written in this area is automatically outputted to segments as display data. "1" data indicates "on" and "0" data "off" (see the section of the LCD circuit for details).

### Data area: \$090 to \$38F (HD404889/HD404899/HD404878 Series) \$090 to \$1BF (HD404868 Series)

For the 464 digits from \$090 to \$25F, the bank can be switched according to the value of the bank register (V: \$03F) (figure 7). The bank register value must always be set when accessing the area from \$090 to \$25F. The data area from \$260 to \$38F can be addressed without a bank register setting.

### Stack area (\$3C0 to \$3FF):

This is the stack area used to save the contents of the program counter (PC), status flag (ST), and carry flag (CA) when a subroutine call (CAL or CALL instruction) or interrupt handling is performed. As four digits are used for one level, the area can be used as a subroutine stack with a maximum of 16 levels. The saved data and saved status information are shown in figure 6. The program counter is restored by the RTN and RTNI instructions. The status and carry flags are restored by the RTNI instruction, but are not affected by the RTN instruction. Any part of the area not used for saving can be used as a data area.

RAM address	Bit 3	Bit 2	Bit 1	Bit 0
\$000	IMWU* <sup>1</sup> ( $\overline{WU}_0$ to $\overline{WU}_3$ interrupt mask)	IFWU* <sup>2</sup> ( $\overline{WU}_0$ to $\overline{WU}_3$ interrupt request flag)	RSP (Stack pointer reset)	IE (Interrupt enable flag)
\$001	IM1 (INT1 interrupt mask)	IF1 (INT1 interrupt request flag)	IM0 ( $\overline{INT}_0$ interrupt mask)	IF0 ( $\overline{INT}_0$ interrupt request flag)
\$002	IMTB (Timer B interrupt mask)	IFTB (Timer B interrupt request flag)	IMTA (Timer A interrupt mask)	IFTA (Timer A interrupt request flag)
\$003	IMAD* <sup>3</sup> (A/D converter interrupt mask)	IFAD* <sup>3</sup> (A/D converter interrupt request flag)	IMTC (Timer C interrupt mask)	IFTC (Timer C interrupt request flag)
\$020	DTON (DTON flag)	ADSF* <sup>3</sup> (A/D start flag)	WDON (Watchdog on flag)	LSON (Low speed on flag)
\$021	GEF (Gear enable flag)	Not used	ICEF (Input capture error flag)	ICSF (Input capture status flag)
\$022	IMTD* <sup>4</sup> (Timer D interrupt mask)	IFTD* <sup>4</sup> (Timer D interrupt request flag)	Not used	Not used
\$023	IMS (Serial interrupt mask)	IFS (Serial interrupt request flag)	Not used	Not used

IF : Interrupt Request Flag  
 IM : Interrupt Mask  
 IE : Interrupt Enable Flag  
 SP : Stack Pointer

- Notes:
1.  $\overline{WU}_0$  to  $\overline{WU}_2$  interrupt mask in the HD404868 Series
  2.  $\overline{WU}_0$  to  $\overline{WU}_2$  interrupt request flag in the HD404868 Series
  3. Applies to the HD404889, HD404899, and HD404868 Series.
  4. Applies to the HD404889, HD404899, and HD404878 Series.

**Figure 3 Interrupt Control Bit and Register Flag Area Configuration**

## HD404889/HD404899/HD404878/HD404868 Series

Bits in the interrupt control bit area and register flag area can be set and reset by the SEM or SEMD instruction and the REM or REMD instruction, and tested by the TM or TMD instruction. They are not affected by any other instructions.

The following restrictions apply to individual bits.

	SEM/SEMD	REM/REMD	TM/TMD
IE	Allowed	Allowed	Allowed
IM			
LSON			
IF	Not executed	Allowed	Allowed
ICSF			
ICEF			
GEF	Allowed	Allowed	Inhibited
RSP	Not executed	Allowed	Inhibited
WDON	Allowed	Not executed	Inhibited
ADSF*	Allowed	Inhibited	Allowed
DTON	Not executed in active mode	Allowed	Allowed
	Used in subactive mode		
Not Used	Not executed	Not executed	Inhibited

Notes : The WDON bit is reset only by stop mode clearance by means of an MCU reset.

Do not use the REM or REMD instruction on the ADSF bit during A/D conversion.

The DTON bit is always in the reset state in active mode.

If the TM or TMD instruction is used on a bit for which its use is prohibited, or on a nonexistent bit, the status flag value will be undetermined.

\* Applies to HD404889, HD404899, and HD404868 Series.

**Figure 4 Instruction Restrictions**

## HD404889 Series

RAM address	Bit 3	Bit 2	Bit 1	Bit 0
\$000	Interrupt control bit area			
\$003	Interrupt control bit area			
SSR \$004	32 kHz oscillation stop setting	32 kHz frequency division ratio selection	System clock selection	System clock frequency division ratio switching
MIS \$005	Pull-up MOS control	Not used	Interrupt frame period selection	
ESR \$006	Not used		INT1 edge detection selection	
\$007	Not used			
PMR0 \$008	Not used		D <sub>1</sub> /INT <sub>1</sub>	D <sub>0</sub> /INT <sub>0</sub>
PMR1 \$009	R0 <sub>3</sub> /WU <sub>3</sub>	R0 <sub>2</sub> /WU <sub>2</sub>	R0 <sub>1</sub> /WU <sub>1</sub>	R0 <sub>0</sub> /WU <sub>0</sub>
PMR2 \$00A	R1 <sub>3</sub> /TOB	R1 <sub>2</sub> /BUZZ	R1 <sub>1</sub> /EVND	R1 <sub>0</sub> /EVNB
PMR3 \$00B	R2 <sub>2</sub> /SI/SO		R2 <sub>1</sub> /SK	R2 <sub>0</sub> /TOC
PMR4 \$00C	R6/SEG13-16	R5/SEG9-12	R4/SEG5-8	R3/SEG1-4
MSR1 \$00D	Not used	Timer D clock on/off	Timer C clock on/off	Timer B lock on/off
MSR2 \$00E	Not used		A/D clock on/off	Serial clock on/off
TMA \$00F	Timer A/Timer base	Timer A clock source selection		
TMB1 \$010	Reload on/off	Timer B clock source selection		
TMB2 \$011	Not used	Timer B output mode setting	EVNB edge detection selection	
TRBL/TWBL \$012	Timer B register (lower)			
TRBU/TWBU \$013	Timer B register (upper)			
TMC1 \$014	Reload on/off	Timer C clock source selection		
TMC2 \$015	Not used	Timer C output mode selection	Not used	
TRCL/TWCL \$016	Timer C register (lower)			
TRCU/TWCU \$017	Timer C register (upper)			
TMD1 \$018	Reload on/off	Timer D clock source selection		
TMD2 \$019	Not used	Input capture selection	EVND edge detection selection	
TRDL/TWDL \$01A	Timer D register (lower)			
TRDU/TWDU \$01B	Timer D register (upper)			
\$01C	Not used			
\$01F	Not used			
\$020	Register flag area			
\$023	Register flag area			
SMR1 \$024	Serial transfer clock speed selection			
SMR2 \$025	Not used	R2/SI/SO PMOS control	SO idle H/L setting	Not used
SRL \$026	Serial data register (lower)			
SRU \$027	Serial data register (upper)			
AMR \$028	Analog channel selection			A/D conversion time
\$029	Not used			
ADRL \$02A	A/D data register (lower)			
ADRU \$02B	A/D data register (upper)			
LCR \$02C	Power supply dividing resistor switch	Realtime clock mode display selection	On-chip power supply switch	Display on/off
LMR \$02D	Input clock selection		Duty selection	
BMR \$02E	Clock output on/off	Buzzer/clock selection	Buzzer/clock source selection	
\$02F	Not used			
DCD0 \$030	PortD <sub>5</sub> DCR	PortD <sub>2</sub> DCR	PortD <sub>1</sub> DCR	PortD <sub>0</sub> DCR
DCD1 \$031	PortD <sub>7</sub> DCR	PortD <sub>6</sub> DCR	PortD <sub>5</sub> DCR	PortD <sub>4</sub> DCR
DCD2 \$032	PortD <sub>11</sub> DCR	PortD <sub>10</sub> DCR	PortD <sub>9</sub> DCR	PortD <sub>8</sub> DCR
\$033	Not used			
DCR0 \$034	PortR0 <sub>3</sub> DCR	PortR0 <sub>2</sub> DCR	PortR0 <sub>1</sub> DCR	PortR0 <sub>0</sub> DCR
DCR1 \$035	PortR1 <sub>3</sub> DCR	PortR1 <sub>2</sub> DCR	PortR1 <sub>1</sub> DCR	PortR1 <sub>0</sub> DCR
DCR2 \$036	PortR2 <sub>3</sub> DCR	PortR2 <sub>2</sub> DCR	PortR2 <sub>1</sub> DCR	PortR2 <sub>0</sub> DCR
DCR3 \$037	PortR3 <sub>3</sub> DCR	PortR3 <sub>2</sub> DCR	PortR3 <sub>1</sub> DCR	PortR3 <sub>0</sub> DCR
DCR4 \$038	PortR4 <sub>3</sub> DCR	PortR4 <sub>2</sub> DCR	PortR4 <sub>1</sub> DCR	PortR4 <sub>0</sub> DCR
DCR5 \$039	PortR5 <sub>3</sub> DCR	PortR5 <sub>2</sub> DCR	PortR5 <sub>1</sub> DCR	PortR5 <sub>0</sub> DCR
DCR6 \$03A	PortR6 <sub>3</sub> DCR	PortR6 <sub>2</sub> DCR	PortR6 <sub>1</sub> DCR	PortR6 <sub>0</sub> DCR
DCR7 \$03B	PortR7 <sub>3</sub> DCR	PortR7 <sub>2</sub> DCR	PortR7 <sub>1</sub> DCR	PortR7 <sub>0</sub> DCR
DCR8 \$03C	Not used		PortR8 <sub>1</sub> DCR	PortR8 <sub>0</sub> DCR
\$03D	Not used			
\$03E	Not used			
V \$03F	Not used			Bank setting

**Figure 5 Special Function Register Area**

# HD404889/HD404899/HD404878/HD404868 Series

## HD404899 Series

RAM address	Bit 3	Bit 2	Bit 1	Bit 0
\$000	Interrupt control bit area			
\$003				
SSR \$004	32 kHz oscillation stop setting	32 kHz frequency division ratio selection	System clock selection	System clock frequency division ratio switching
MIS \$005	Pull-up MOS control	Not used	Interrupt frame period selection	
ESR \$006	Not used		INT1 edge detection selection	
\$007	Not used			
PMR0 \$008	Not used		D <sub>1</sub> /INT <sub>1</sub>	D <sub>0</sub> /INT <sub>0</sub>
PMR1 \$009	R0 <sub>3</sub> /WU <sub>3</sub>	R0 <sub>2</sub> /WU <sub>2</sub>	R0 <sub>1</sub> /WU <sub>1</sub>	R0 <sub>0</sub> /WU <sub>0</sub>
PMR2 \$00A	R1 <sub>3</sub> /TOB	R1 <sub>2</sub> /BUZZ	R1 <sub>1</sub> /EVND	R1 <sub>0</sub> /EVNB
PMR3 \$00B	R2 <sub>2</sub> /SI/SO		R2 <sub>1</sub> /SCK	R2 <sub>0</sub> /TOC
PMR4 \$00C	R6/SEG13~16	R5/SEG9~12	R4/SEG5~8	R3/SEG1~4
MSR1 \$00D	Not used	Timer D clock on/off	Timer C clock on/off	Timer B lock on/off
MSR2 \$00E	Not used		A/D clock on/off	Serial clock on/off
TMA \$00F	TimerA/Timer base	Timer A clock source selection		
TMB1 \$010	Reload on/off	Timer B clock source selection		
TMB2 \$011	Not used	Timer B output mode setting	EVNB edge detection selection	
TRBL/TWBL \$012	Timer B register (lower)			
TRBU/TWBU \$013	Timer B register (upper)			
TMC1 \$014	Reload on/off	Timer C clock source selection		
TMC2 \$015	Not used	Timer C output mode selection	Not used	
TRCL/TWCL \$016	Timer C register (lower)			
TRCU/TWCU \$017	Timer C register (upper)			
TMD1 \$018	Reload on/off	Timer D clock source selection		
TMD2 \$019	Not used	Input capture selection	EVND edge detection selection	
TRDL/TWDL \$01A	Timer D register (lower)			
TRDU/TWDU \$01B	Timer D register (upper)			
\$01C	Not used			
\$01F				
\$020	Register flag area			
\$023	Serial transfer clock speed selection			
SMR1 \$024	Not used	R2 <sub>2</sub> /SI/SO PMOS control	SO idle H/L setting	Not used
SMR2 \$025	Serial data register (lower)			
SRL \$026	Serial data register (upper)			
SRU \$027	Analog channel selection			A/D conversion time
AMR \$028	A/D data register (lower)		Not used	
ADRL \$029	A/D data register (middle)			
ADRM \$02A	A/D data register (upper)			
ADRU \$02B	Power supply dividing resistor switch	Realtime clock mode display selection	On-chip power supply switch	Display on/off
LCR \$02C	Input clock selection		Duty selection	
LMR \$02D	Clock output on/off	Buzzer/clock selection	Buzzer/clock source selection	
BMR \$02E	Not used			
\$02F	Not used			
DCD0 \$030	PortD <sub>3</sub> DCR	PortD <sub>2</sub> DCR	PortD <sub>1</sub> DCR	PortD <sub>0</sub> DCR
DCD1 \$031	PortD <sub>7</sub> DCR	PortD <sub>6</sub> DCR	PortD <sub>5</sub> DCR	PortD <sub>4</sub> DCR
DCD2 \$032	PortD <sub>11</sub> DCR	PortD <sub>10</sub> DCR	PortD <sub>9</sub> DCR	PortD <sub>8</sub> DCR
\$033	Not used			
DCR0 \$034	PortR0 <sub>3</sub> DCR	PortR0 <sub>2</sub> DCR	PortR0 <sub>1</sub> DCR	PortR0 <sub>0</sub> DCR
DCR1 \$035	PortR1 <sub>3</sub> DCR	PortR1 <sub>2</sub> DCR	PortR1 <sub>1</sub> DCR	PortR1 <sub>0</sub> DCR
DCR2 \$036	PortR2 <sub>3</sub> DCR	PortR2 <sub>2</sub> DCR	PortR2 <sub>1</sub> DCR	PortR2 <sub>0</sub> DCR
DCR3 \$037	PortR3 <sub>3</sub> DCR	PortR3 <sub>2</sub> DCR	PortR3 <sub>1</sub> DCR	PortR3 <sub>0</sub> DCR
DCR4 \$038	PortR4 <sub>3</sub> DCR	PortR4 <sub>2</sub> DCR	PortR4 <sub>1</sub> DCR	PortR4 <sub>0</sub> DCR
DCR5 \$039	PortR5 <sub>3</sub> DCR	PortR5 <sub>2</sub> DCR	PortR5 <sub>1</sub> DCR	PortR5 <sub>0</sub> DCR
DCR6 \$03A	PortR6 <sub>3</sub> DCR	PortR6 <sub>2</sub> DCR	PortR6 <sub>1</sub> DCR	PortR6 <sub>0</sub> DCR
DCR7 \$03B	PortR7 <sub>3</sub> DCR	PortR7 <sub>2</sub> DCR	PortR7 <sub>1</sub> DCR	PortR7 <sub>0</sub> DCR
DCR8 \$03C	Not used		PortR8 <sub>1</sub> DCR	PortR8 <sub>0</sub> DCR
\$03D	Not used			
\$03E	Not used			
V \$03F	Not used			Bank setting

Figure 5 Special Function Register Area (cont)

## HD404878 Series

RAM address	Bit 3	Bit 2	Bit 1	Bit 0
\$000	Interrupt control bit area			
\$003	Interrupt control bit area			
SSR \$004	32 kHz oscillation stop setting	32 kHz frequency division ratio selection	System clock selection	System clock frequency division ratio switching
MIS \$005	Pull-up MOS control	Not used	Interrupt frame period selection	
ESR \$006	Not used		INT1 edge detection selection	
\$007	Not used			
PMR0 \$008	Not used		D <sub>1</sub> /INT <sub>1</sub>	D <sub>0</sub> /INT <sub>0</sub>
PMR1 \$009	R <sub>03</sub> /WU <sub>3</sub>	R <sub>02</sub> /WU <sub>2</sub>	R <sub>01</sub> /WU <sub>1</sub>	R <sub>00</sub> /WU <sub>0</sub>
PMR2 \$00A	R <sub>13</sub> /TOB	R <sub>12</sub> /BUZZ	R <sub>11</sub> /EVND	R <sub>10</sub> /EVNB
PMR3 \$00B	R <sub>2</sub> /SI/SO		R <sub>21</sub> /SCK	R <sub>20</sub> /TOC
PMR4 \$00C	R <sub>6</sub> /SEG13~16	R <sub>5</sub> /SEG9~12	R <sub>4</sub> /SEG5~8	R <sub>3</sub> /SEG1~4
MSR1 \$00D	Not used	Timer D clock on/off	Timer C clock on/off	Timer B lock on/off
MSR2 \$00E	Not used			Serial clock on/off
TMA \$00F	TimerA/Timer base	Timer A clock source selection		
TMB1 \$010	Reload on/off	Timer B clock source selection		
TMB2 \$011	Not used	Timer B output mode setting	EVNB edge detection selection	
TRBL/TWBL \$012	Timer B register (lower)			
TRBU/TWBU \$013	Timer B register (upper)			
TMC1 \$014	Reload on/off	Timer C clock source selection		
TMC2 \$015	Not used	Timer C output mode selection	Not used	
TRCL/TWCL \$016	Timer C register (lower)			
TRCU/TWCU \$017	Timer C register (upper)			
TMD1 \$018	Reload on/off	Timer D clock source selection		
TMD2 \$019	Not used	Input capture selection	EVND edge detection selection	
TRDL/TWDL \$01A	Timer D register (lower)			
TRDU/TWDU \$01B	Timer D register (upper)			
\$01C	Not used			
\$01F	Not used			
\$020	Register flag area			
\$023	Register flag area			
SMR1 \$024	Serial transfer clock speed selection			
SMR2 \$025	Not used	R <sub>2</sub> /SI/SO PMOS control	SO idle H/L setting	Not used
SRL \$026	Serial data register (lower)			
SRU \$027	Serial data register (upper)			
\$028	Not used			
\$029	Not used			
\$02A	Not used			
\$02B	Not used			
LCR \$02C	Power supply dividing resistor switch	Realtime clock mode display selection	On-chip power supply switch	Display on/off
LMR \$02D	Input clock selection		Duty selection	
BMR \$02E	Clock output on/off	Buzzer/clock selection	Buzzer/clock source selection	
\$02F	Not used			
DCD0 \$030	PortD <sub>3</sub> DCR	PortD <sub>2</sub> DCR	PortD <sub>1</sub> DCR	PortD <sub>0</sub> DCR
DCD1 \$031	PortD <sub>7</sub> DCR	PortD <sub>6</sub> DCR	PortD <sub>5</sub> DCR	PortD <sub>4</sub> DCR
DCD2 \$032	PortD <sub>11</sub> DCR	PortD <sub>10</sub> DCR	PortD <sub>9</sub> DCR	PortD <sub>8</sub> DCR
\$033	Not used			
DCR0 \$034	PortR <sub>03</sub> DCR	PortR <sub>02</sub> DCR	PortR <sub>01</sub> DCR	PortR <sub>00</sub> DCR
DCR1 \$035	PortR <sub>13</sub> DCR	PortR <sub>12</sub> DCR	PortR <sub>11</sub> DCR	PortR <sub>10</sub> DCR
DCR2 \$036	PortR <sub>23</sub> DCR	PortR <sub>22</sub> DCR	PortR <sub>21</sub> DCR	PortR <sub>20</sub> DCR
DCR3 \$037	PortR <sub>33</sub> DCR	PortR <sub>32</sub> DCR	PortR <sub>31</sub> DCR	PortR <sub>30</sub> DCR
DCR4 \$038	PortR <sub>43</sub> DCR	PortR <sub>42</sub> DCR	PortR <sub>41</sub> DCR	PortR <sub>40</sub> DCR
DCR5 \$039	PortR <sub>53</sub> DCR	PortR <sub>52</sub> DCR	PortR <sub>51</sub> DCR	PortR <sub>50</sub> DCR
DCR6 \$03A	PortR <sub>63</sub> DCR	PortR <sub>62</sub> DCR	PortR <sub>61</sub> DCR	PortR <sub>60</sub> DCR
DCR7 \$03B	PortR <sub>73</sub> DCR	PortR <sub>72</sub> DCR	PortR <sub>71</sub> DCR	PortR <sub>70</sub> DCR
DCR8 \$03C	Not used		PortR <sub>81</sub> DCR	PortR <sub>80</sub> DCR
\$03D	Not used			
\$03E	Not used			
\$03F	Not used			

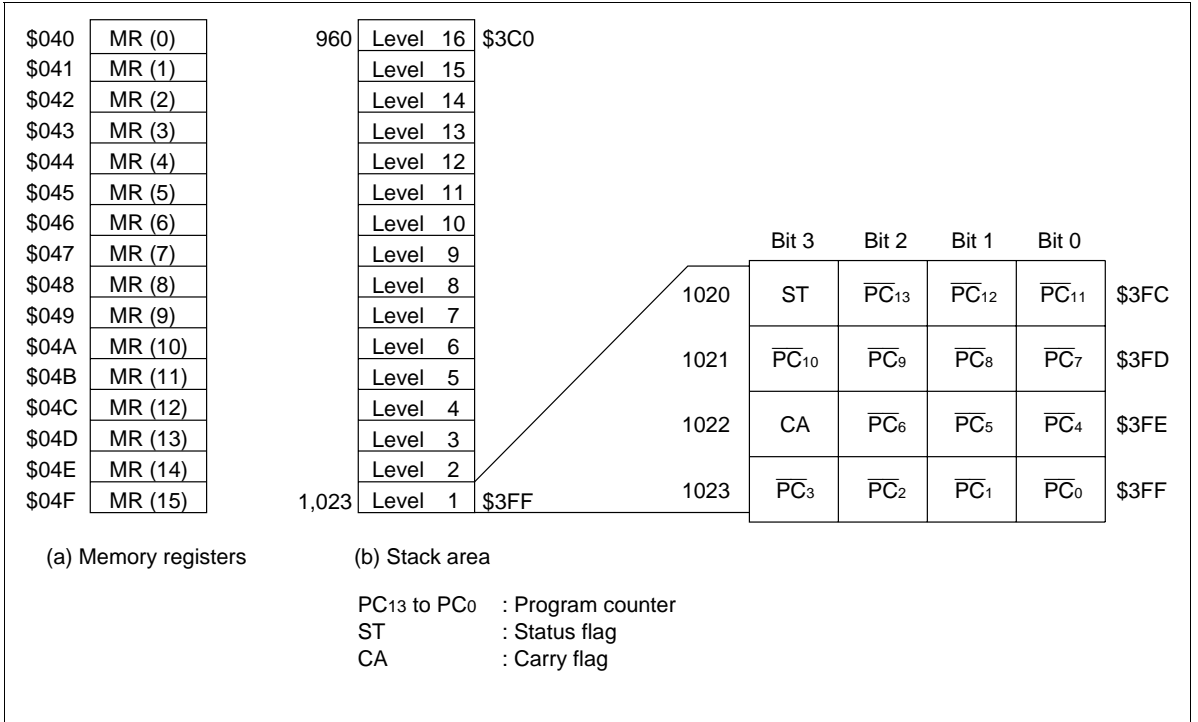
**Figure 5 Special Function Register Area (cont)**

# HD404889/HD404899/HD404878/HD404868 Series

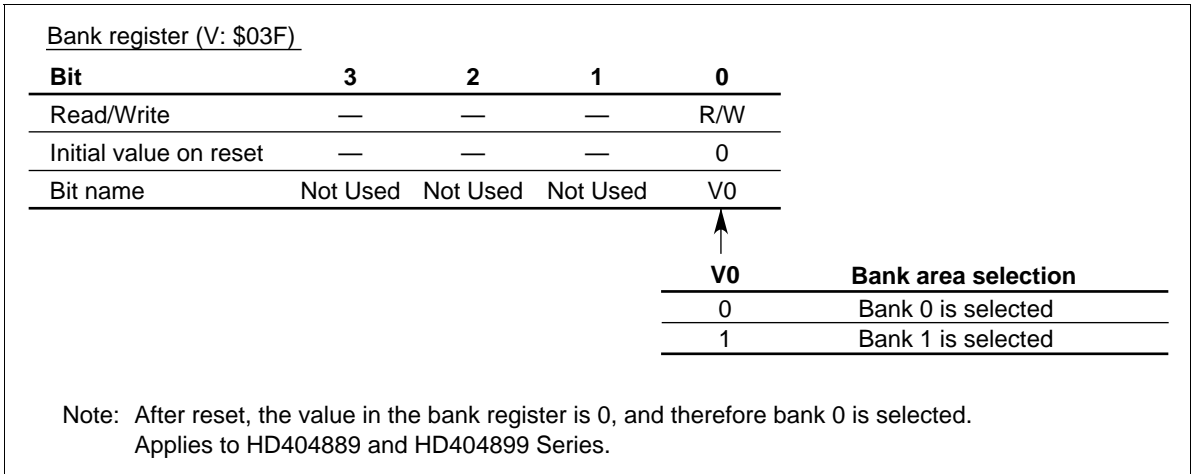
## HD404868 Series

RAM address	Bit 3	Bit 2	Bit 1	Bit 0
\$000	Interrupt control bit area			
\$003				
SSR \$004	32 kHz oscillation stop setting	32 kHz frequency division ratio selection	System clock selection	System clock frequency division ratio switching
MIS \$005	Pull-up MOS control	Not used	Interrupt frame period selection	
ESR \$006	Not used		INT1 edge detection selection	
\$007	Not used			
PMR0 \$008	Not used		D <sub>1</sub> /INT <sub>1</sub>	D <sub>0</sub> /INT <sub>0</sub>
PMR1 \$009	Not used	R <sub>02</sub> /WU <sub>2</sub>	R <sub>01</sub> /WU <sub>1</sub>	R <sub>00</sub> /WU <sub>0</sub>
PMR2 \$00A	R <sub>13</sub> /TOB	R <sub>12</sub> /BUZZ	Not used	R <sub>10</sub> /EVNB
PMR3 \$00B	R <sub>22</sub> /SI/SO		R <sub>21</sub> /SCK	R <sub>20</sub> /TOC
PMR4 \$00C	R <sub>6</sub> /SEG13~16	R <sub>5</sub> /SEG9~12	R <sub>4</sub> /SEG5~8	R <sub>3</sub> /SEG1~4
MSR1 \$00D	Not used		Timer C clock on/off	Timer B lock on/off
MSR2 \$00E	Not used		A/D clock on/off	Serial clock on/off
TMA \$00F	TimerA/Timer base	Timer A clock source selection		
TMB1 \$010	Reload on/off	Timer B clock source selection		
TMB2 \$011	Not used	Timer B output mode selection	EVNB edge detection selection	
TRBL/TWBL \$012	Timer B register (lower)			
TRBU/TWBU \$013	Timer B register (upper)			
TMC1 \$014	Reload on/off	Timer C clock source selection		
TMC2 \$015	Not used	Timer C output mode selection	Not used	
TRCL/TWCL \$016	Timer C register (lower)			
TRCU/TWCU \$017	Timer C register (upper)			
\$018	Not used			
\$019	Not used			
\$01A	Not used			
\$01B	Not used			
\$01C	Not used			
\$01F	Not used			
\$020	Register flag area			
\$023	Serial transfer clock speed selection			
SMR1 \$024	Serial transfer clock speed selection			
SMR2 \$025	Not used	R <sub>22</sub> /SI/SO PMOS control	SO idle H/L setting	Not used
SRL \$026	Serial data register (lower)			
SRU \$027	Serial data register (upper)			
AMR \$028	Analog channel selection			A/D conversion time
ADRL \$029	A/D data register (lower)		Not used	
ADRM \$02A	A/D data register (middle)			
ADRU \$02B	A/D data register (upper)			
LCR \$02C	Power supply dividing resistor switch	Realtime clock mode display selection	On-chip power supply switch	Display on/off
LMR \$02D	Input clock selection		Duty selection	
BMR \$02E	Clock output on/off	Buzzer/clock selection	Buzzer/clock source selection	
\$02F	Not used			
DCD0 \$030	PortD <sub>3</sub> DCR	PortD <sub>2</sub> DCR	PortD <sub>1</sub> DCR	PortD <sub>0</sub> DCR
DCD1 \$031	PortD <sub>7</sub> DCR	PortD <sub>6</sub> DCR	PortD <sub>5</sub> DCR	PortD <sub>4</sub> DCR
DCD2 \$032	Not used		PortD <sub>9</sub> DCR	PortD <sub>8</sub> DCR
\$033	Not used			
DCR0 \$034	Not used	PortR <sub>02</sub> DCR	PortR <sub>01</sub> DCR	PortR <sub>00</sub> DCR
DCR1 \$035	PortR <sub>13</sub> DCR	PortR <sub>12</sub> DCR	PortR <sub>11</sub> DCR	PortR <sub>10</sub> DCR
DCR2 \$036	PortR <sub>23</sub> DCR	PortR <sub>22</sub> DCR	PortR <sub>21</sub> DCR	PortR <sub>20</sub> DCR
DCR3 \$037	PortR <sub>33</sub> DCR	PortR <sub>32</sub> DCR	PortR <sub>31</sub> DCR	PortR <sub>30</sub> DCR
DCR4 \$038	PortR <sub>43</sub> DCR	PortR <sub>42</sub> DCR	PortR <sub>41</sub> DCR	PortR <sub>40</sub> DCR
DCR5 \$039	PortR <sub>53</sub> DCR	PortR <sub>52</sub> DCR	PortR <sub>51</sub> DCR	PortR <sub>50</sub> DCR
DCR6 \$03A	PortR <sub>63</sub> DCR	PortR <sub>62</sub> DCR	PortR <sub>61</sub> DCR	PortR <sub>60</sub> DCR
DCR7 \$03B	PortR <sub>73</sub> DCR	PortR <sub>72</sub> DCR	PortR <sub>71</sub> DCR	PortR <sub>70</sub> DCR
\$03C	Not used			
\$03D	Not used			
\$03E	Not used			
\$03F	Not used			

Figure 5 Special Function Register Area (cont)



**Figure 6 Configuration of Memory Registers and Stack Area, and Stack Position**

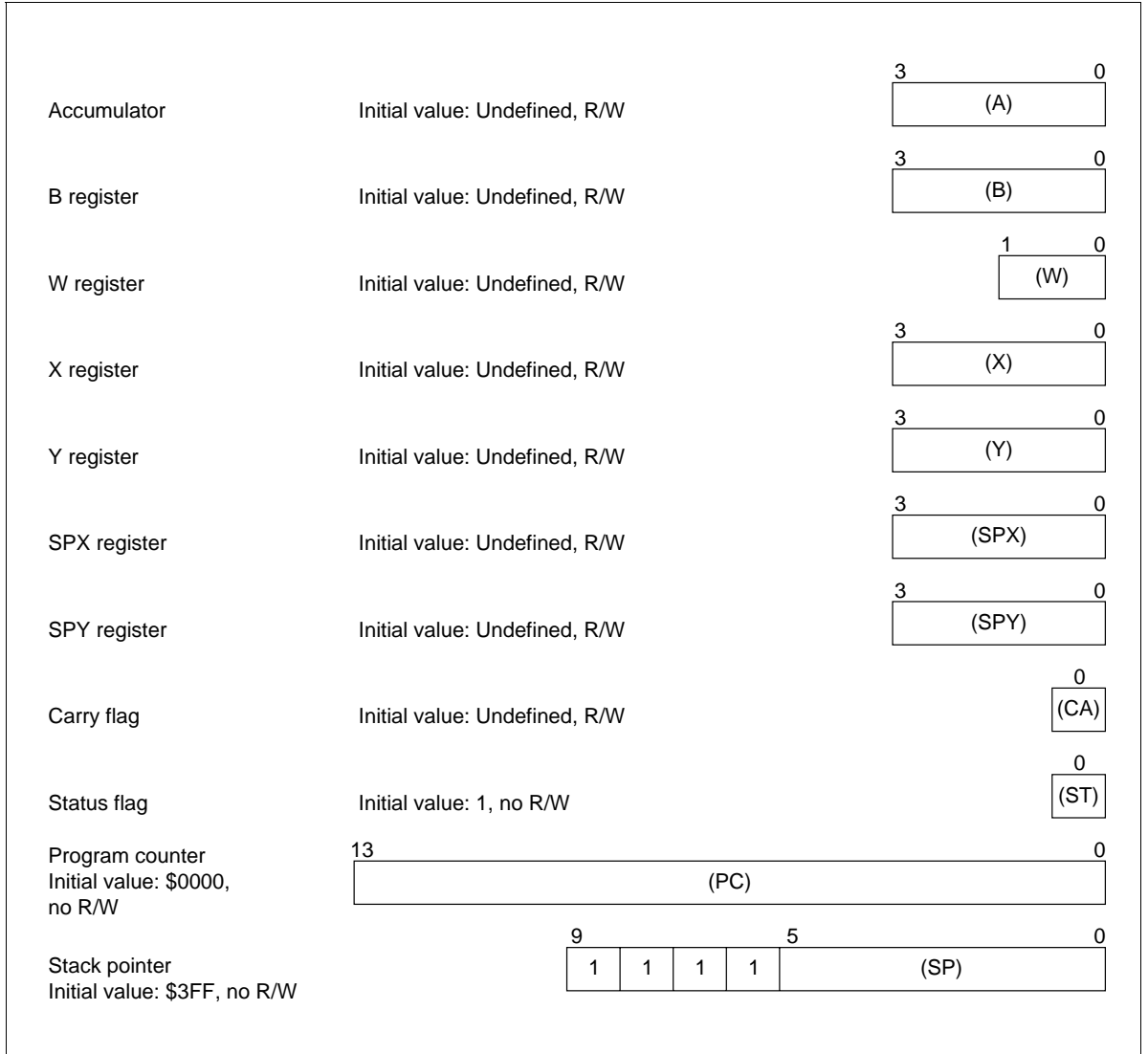


**Figure 7 Bank Register (V)**

**Functional Description**

**Registers and Flags**

The MCU has nine registers and two flags for CPU operations. they are shown in figure 8 and described below.



**Figure 8 Registers and Flags**

**Accumulator (A) and B register (B):**

The accumulator and B register are 4-bit registers used to hold the result of an ALU operation, and for data transfer to or from memory, an I/O area, or another register.

**W register (W), X register (X) and Y register (Y):**

The W register is a 2-bit register, and the X and Y registers are 4-bit registers, used for RAM register indirect addressing. The Y register is also used for D port addressing.

**SPX register (SPX) and SPY register (SPY):**

The SPX and SPY registers are 4-bit registers used as X register and Y register auxiliary registers, respectively.

**Carry flag (CA):**

This flag holds ALU overflow when an arithmetic/logic instruction is executed. It is also affected by the SEC, REC, ROTL, and ROTR instructions. The contents of the carry flag are saved to the stack when interrupt handling is performed, and are restored from the stack by the RTNI instruction (but are not affected by the RTN instruction).

**Status flag (ST):**

This flag holds ALU overflow when an arithmetic/logic or compare instruction is executed, and the result of an ALU non-zero or bit test instruction. It is used as the branch condition for the BR, BRL, CAL, and CALL instructions. The status flag is a latch-type flag, and does not change until the next arithmetic/logic, compare, or bit test instruction is executed. After a BR, BRL, CAL, or CALL instruction, the status flag is set to 1 regardless of whether the instruction is executed or skipped. The contents of the status flag are saved to the stack when interrupt handling is performed, and are restored from the stack by the RTNI instruction (but are not affected by the RTN instruction).

**Program counter (PC):**

This is a 14-bit binary counter that holds ROM address information.

**Stack pointer (SP):**

The stack pointer is a 10-bit register that holds the address of the next save space in the stack area. The stack pointer is initialized to \$3FF by an MCU reset. The stack pointer is decremented by 4 each time data is saved, and incremented by 4 each time data is restored. The upper 4 bits of the stack pointer are fixed at 1111, so that a maximum of 16 stack levels can be used.

There are two ways in which the stack pointer is initialized to \$3FF: by an MCU reset as mentioned above, or by resetting the RSP bit with the REM or REMD instruction.

**Reset**

An MCU reset is performed by driving the  $\overline{\text{RESET}}$  pin low. At power-on, and when subactive mode, watch mode, or stop mode is cleared,  $\overline{\text{RESET}}$  should be input for at least  $t_{RC}$  to provide the oscillation settling time for the oscillator. In other cases, the MCU is reset by inputting  $\overline{\text{RESET}}$  for at least two instruction cycles.

Table 1 shows the areas initialized by an MCU reset, and their initial values.

# HD404889/HD404899/HD404878/HD404868 Series

**Table 1 (1) Initial Values after MCU Reset**

Item	Abbr.	Initial value	Contents	
Program counter	(PC)	\$0000	Program executed from ROM start address	
Status flag	(ST)	1	Branching by conditional branch instruction enabled	
Stack pointer	(SP)	\$3FF	Stack level is 0	
Interrupt	Interrupt enable flag	(IE)	0	All interrupts disabled
flags/ mask	Interrupt request flag	(IF)	0	No interrupt requests
	Interrupt mask	(IM)	1	Interrupt requests masked
I/O	Port data register	(PDR)	All bits 1	"1" level output possible
	Data control registers	(DCD0 to 2)	All bits 0	Output buffer off (high impedance)
	Data control registers	(DCR0 to 7, DCR80, DCR81)	All bits 0	
	Port mode register 0	(PMR0)	--00	See port mode register 0 section
	Port mode register 1	(PMR1)	0000	See port mode register 1 section
	Port mode register 2	(PMR2)	0000	See port mode register 2 section
	Port mode register 3	(PMR3)	0000	See port mode register 3 section
	Port mode register 4	(PMR4)	0000	See port mode register 4 section
	Edge detection select register	(ESR)	--00	See edge detection select register section
	Timers	Timer mode register A	(TMA)	0000
Timer mode register B1		(TMB1)	0000	See timer mode register B1 section
Timer mode register B2		(TMB2)	-000	See timer mode register B2 section
Timer mode register C1		(TMC1)	0000	See timer mode register C1 section
Timer mode register C2		(TMC2)	-0--	See timer mode register C2 section
Timer mode register D1		(TMD1)	0000	See timer mode register D1 section
Timer mode register D2		(TMD2)	-000	See timer mode register D2 section
Prescaler S		(PSS)	\$000	
Prescaler W		(PSW)	\$00	
Timer/counter A		(TCA)	\$00	
Timer/counter B		(TCB)	\$00	
Timer/counter C		(TCC)	\$00	
Timer/counter D		(TCD)	\$00	
Timer write register B		(TWBU,L)	\$X0	
Timer write register C		(TWCU,L)	\$X0	
Timer write register D		(TWDU,L)	\$X0	

**Table 1 (1) (cont) Initial Values after MCU Reset**

Item		Abbr.	Initial value	Contents
Serial interface	Serial mode register 1	(SMR1)	0000	See serial mode register 1 section
	Serial mode register 2	(SMR2)	-0X-	See serial mode register 2 section
	Serial data register	(SRU,L)	\$XX	
	Octal counter		000	
A/D converter	A/D mode register	(AMR)	0000	See A/D mode register section
	A/D data register (HD404889 Series)	(ADRU,L)	\$7F	See A/D data register section
	A/D data register (HD404899 Series)	(ADRU,M,L)	\$1FF	See A/D data register section
LCD	LCD control register	(LCR)	0000	See LCD control register section
	LCD mode register	(LMR)	0000	See LCD duty/clock control register section
Bit registers	Low speed on flag	(LSON)	0	See low-power mode section
	Watchdog timer on flag	(WDON)	0	See timer C section
	A/D start flag	(ADSF)	0	See A/D converter section
	Direct transfer on flag	(DTON)	0	See low-power mode section
	Input capture status flag	(ICSF)	0	See timer D section
	Input capture error flag	(ICEF)	0	See timer D section
	Gear enable flag	(GEF)	0	See system clock gear function
Others	Miscellaneous register	(MIS)	0-00	See low-power mode and input/output sections
	System clock select register	(SSR)	0000	See low-power mode and oscillator circuit sections
	Module standby register 1	(MSR1)	-000	See timer section
	Module standby register 2	(MSR2)	--00	See serial interface and A/D converter sections
	Buzzer mode register	(BMR)	0000	See Buzzer mode register section

Notes: 1. The state of registers and flags other than those listed above after an MCU reset is shown in table 1 (2).

2. X: Indicates invalid value, - indicates that the bit does not exist.

**Table 1 (2) Initial Values after MCU Reset**

Item	Abbr.	After Stop Mode Clearance by $\overline{WU}_0$ to $\overline{WU}_3$ Input	After Other MCU Reset
Carry flag	(CA)	Retain value immediately prior to entering stop mode	Value immediately prior to MCU reset is not guaranteed. Must be initialized by program.
Accumulator	(A)		
B register	(B)		
W register	(W)		
X/SPX register	(X/SPX)		
Y/SPY register	(Y/SPY)		
RAM			

## Interrupts

There are a total of nine interrupt sources, comprising wakeup input ( $\overline{WU}_0$  to  $\overline{WU}_3$ ), external interrupts ( $\overline{INT}_0$ ,  $INT_1$ ), timer/counter (timer A, timer B, timer C, timer D) interrupts, a serial interface interrupt, and an A/D converter interrupt.

Each interrupt source is provided with an interrupt request flag, interrupt mask, and vector address, used for storing and controlling interrupt requests. In addition, an interrupt enable flag is provided to control interrupts as a whole.

Of the interrupt sources, timers B and D share the same vector address, and the A/D converter and serial interface also share the same vector address. Software must therefore determine which of the interrupt sources is requesting an interrupt at the start of interrupt handling.

### Interrupt control bits and interrupt handling:

The interrupt control bits are mapped onto RAM addresses \$000 to \$003 and \$022 to \$023, and can be accessed by RAM bit manipulation instructions. However, the interrupt request flags (IF) cannot be set by software. When the MCU is reset, the interrupt enable flag (IE) and interrupt request flags (IF) are initialized to 0, and the interrupt masks (IM) are initialized to 1.

Figure 9 shows a block diagram of the interrupt control circuit, table 2 shows interrupt priorities and vector addresses, and table 3 lists the conditions for executing interrupt handling for each of the nine kinds of interrupt source. When the interrupt request flag is set to 1 and the interrupt mask is cleared to 0, an interrupt is requested. If the interrupt enable flag is set to 1 at this time, interrupt handling is started. The vector address corresponding to the interrupt source is generated by the priority control circuit.

The interrupt handling sequence is shown in figure 10, and the interrupt handling flowchart in figure 11. When an interrupt is accepted, execution of the previous instruction is completed in the first cycle. In the second cycle, the interrupt enable flag (IE) is reset. In the second and third cycles, the contents of the carry flag, status flag, and program counter are saved on the stack. In the third cycle, a jump is made to the vector address and instruction execution is resumed from that address.

In each vector address area, a JMWL instruction should be written that branches to the start address of the interrupt routine. In the interrupt routine, the interrupt request flag that caused interrupt handling must be reset by software.

**Table 2** Vector Addresses and Interrupt Priorities

<b>Interrupt Source</b>	<b>Priority</b>	<b>Vector Address</b>
RESET	—	\$0000
$\overline{WU}_0$ to $\overline{WU}_3$	1	\$0002
$\overline{INT}_0$	2	\$0004
$INT_1$	3	\$0006
Timer A	4	\$0008
Timer B, D	5	\$000A
Timer C	6	\$000C
Serial interface, A/D converter	7	\$000E

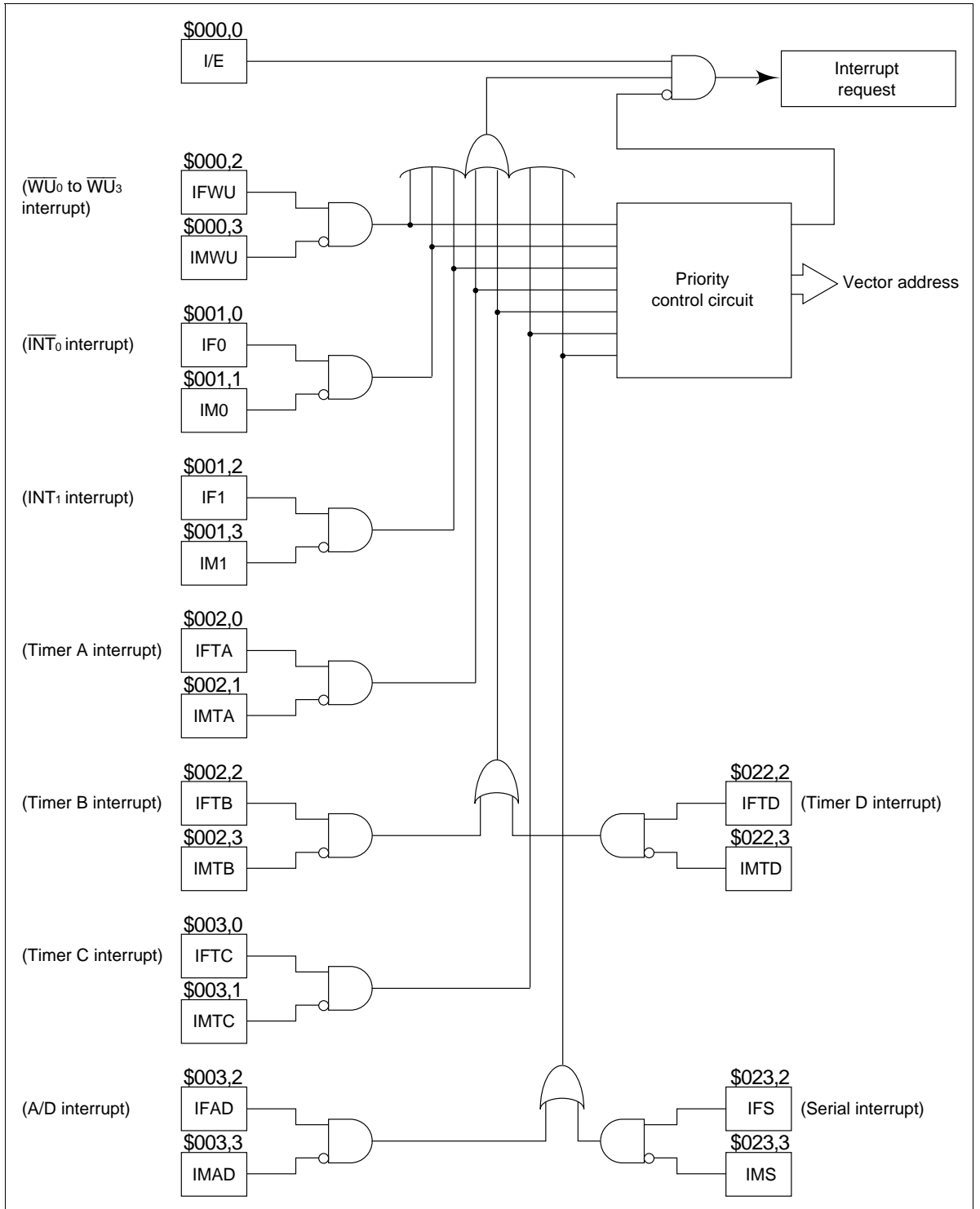
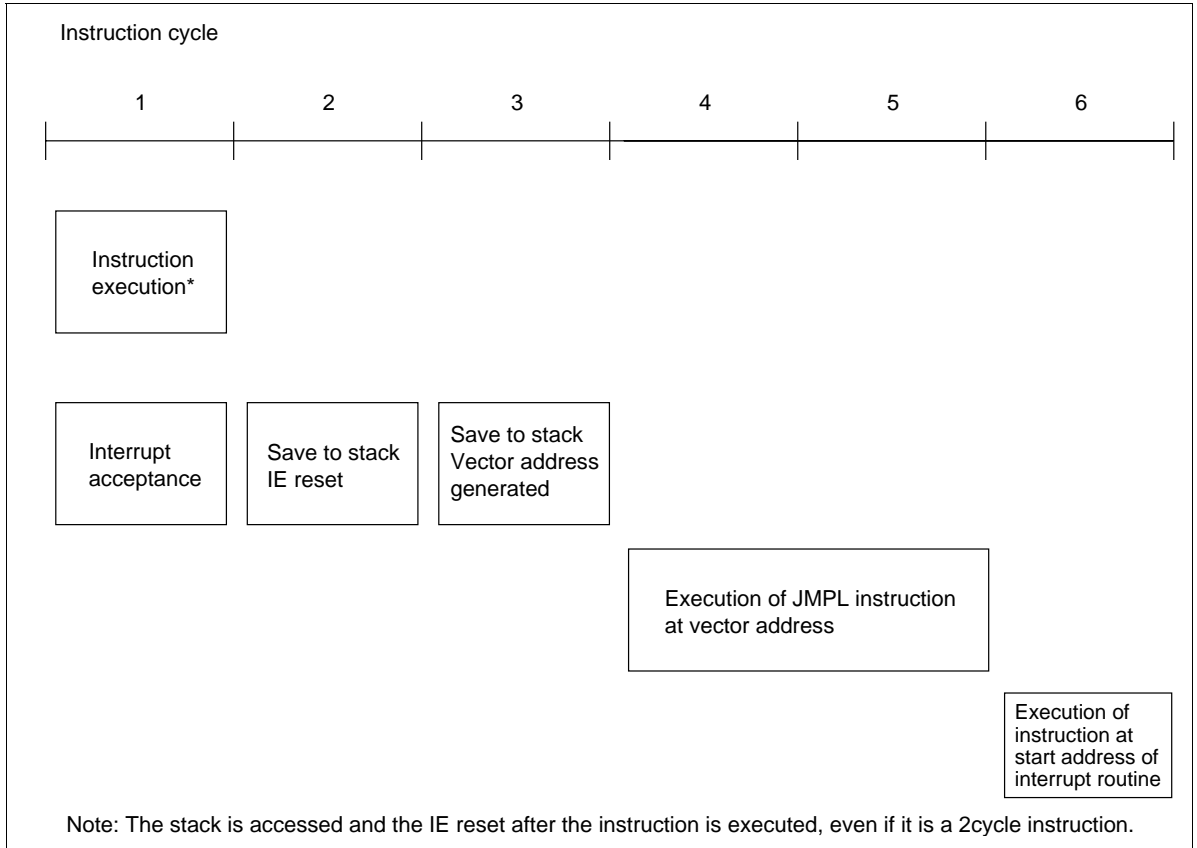


Figure 9 Block Diagram of Interrupt Control Circuit

**Table 3 Interrupt Processing and Activation Conditions**

Interrupt Control Bit	Interrupt Source						
	WU <sub>0</sub> to WU <sub>3</sub>	INT <sub>0</sub>	INT <sub>1</sub>	Timer A	Timer B or Timer D	Timer C	A/D or Serial
IE	1	1	1	1	1	1	1
IFWU· $\overline{\text{IMWU}}$	1	0	0	0	0	0	0
IF0· $\overline{\text{IM0}}$	*	1	0	0	0	0	0
IF1· $\overline{\text{IM1}}$	*	*	1	0	0	0	0
IFTA· $\overline{\text{IMTA}}$	*	*	*	1	0	0	0
IFTB· $\overline{\text{IMTB}}$ +IFTD· $\overline{\text{IMTD}}$	*	*	*	*	1	0	0
IFTC· $\overline{\text{IMTC}}$	*	*	*	*	*	1	0
IFAD· $\overline{\text{IMAD}}$ +IFS· $\overline{\text{IMS}}$	*	*	*	*	*	*	1

Note: \* Operation is not affected whether the value is 0 or 1.



**Figure 10 Interrupt Sequence**

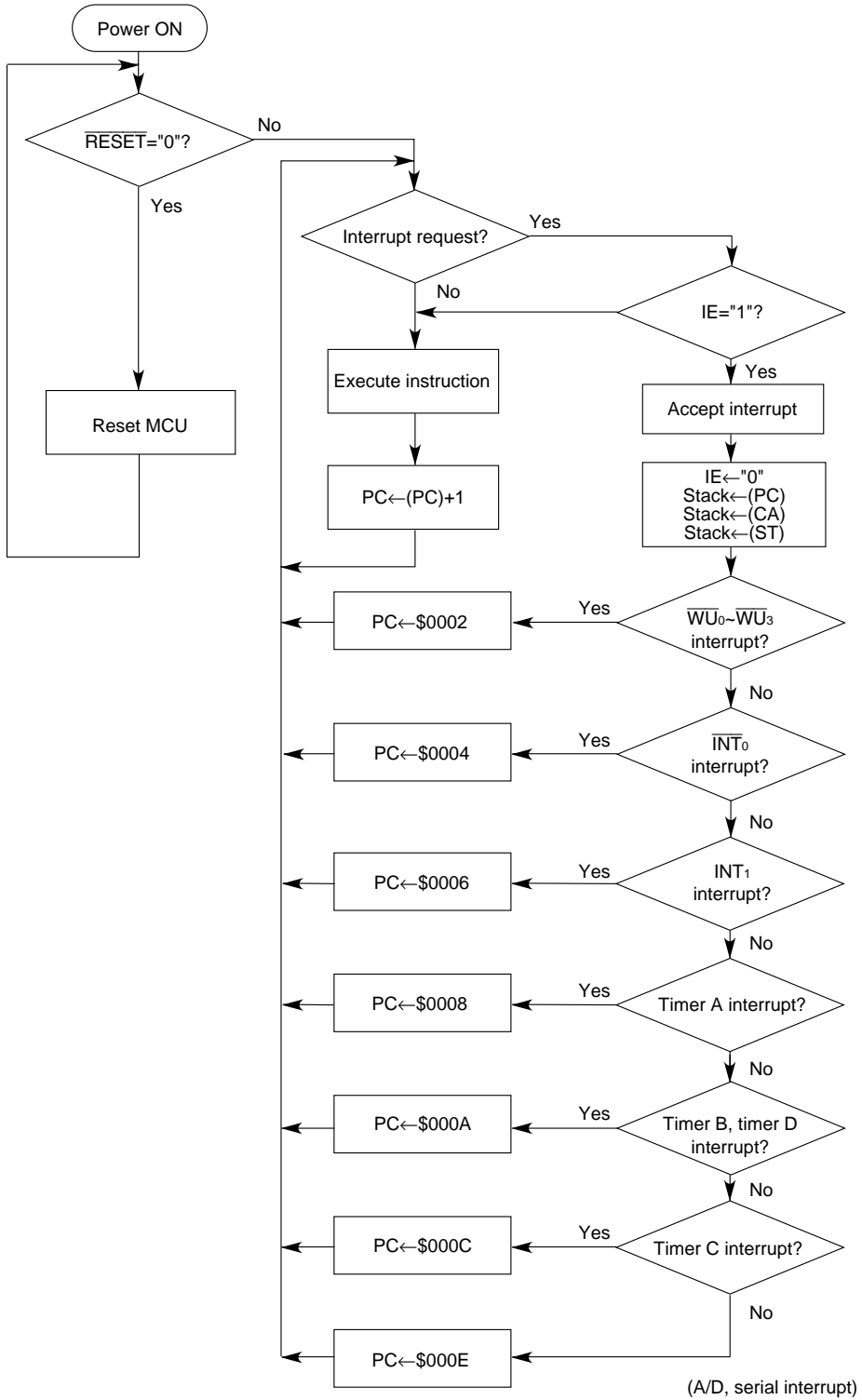


Figure 11 Interrupt Handling Flowchart

### Interrupt enable flag (IE: \$000,0):

The interrupt enable flag controls interrupt enabling/disabling of all interrupt requests as shown in table 4. The interrupt enable flag is reset by interrupt handling and set by the RTNI instruction.

**Table 4 Interrupt Enable Flag (IE: \$000,0)**

Interrupt Enable Flag(IE)	Interrupt Enabling/Disabling
0	Interrupts disabled
1	Interrupts enabled

### Wakeup interrupt request flag (IFWU: \$000,2):

The wakeup interrupt request flag (IFWU) is set by the detection of a falling edge in  $\overline{WU}_0$  to  $\overline{WU}_3$  input in active mode, subactive mode, watch mode, or standby mode. In stop mode, when a falling edge is detected at the wakeup pin, the MCU waits for the oscillation settling time, then switches to active mode. The wakeup interrupt request flag (IFWU) is not set in this case.

### Wakeup interrupt mask (IMWU: \$000,3):

This bit masks an interrupt request by the wakeup interrupt request flag.

Edge detection select register (ESR: \$006)				
Bit	3	2	1	0
Read/Write	—	—	W	W
Initial value on reset	—	—	0	0
Bit name	—	—	ESR1	ESR0

↑	↑	
ESR1	ESR0	INT <sub>1</sub> edge detect
0	0	Not detected
0	1	Falling edge detection
1	0	Rising edge detection
1	1	Both rising and falling edge detection

**Figure 12 Edge Detection Select Register (ESR)**

**External interrupt request flags (IF0, IF1: \$001):**

IF0 is set by a falling edge in the  $\overline{INT}_0$  input, and IF1 is set by a rising edge, falling edge, or both edges in the  $INT_1$  input (table 5).

Interrupt edge selection is performed by means of the edge detection select register (ESR: \$006) (figure 12).

**Table 5 External Interrupt Request Flags (IF0, IF1: \$001)**

External Interrupt Request Flags (IF0, IF1)	Interrupt Request
0	No external interrupt request
1	External interrupt request generated

**External interrupt masks (IM0, IM1: \$001):**

These bits mask interrupt requests by the external interrupt request flags (table 6).

**Table 6 External Interrupt Mask (IM: \$001)**

External Interrupt Masks (IM0, IM1)	Interrupt Request
0	External interrupt request enabled
1	External interrupt request masked (held pending)

**Timer A interrupt request flag (IFTA: \$002,0):**

The timer A interrupt request flag is set by timer A overflow output (table 7).

**Table 7 Timer A Interrupt Request Flag (IFTA: \$002,0)**

Timer A Interrupt Request Flag (IFTA)	Interrupt Request
0	No timer A interrupt request
1	Timer A interrupt request generated

**Timer A interrupt mask (IMTA: \$002,1):**

This bit masks an interrupt request by the timer A interrupt request flag (table 8).

**Table 8 Timer A Interrupt Mask (IMTA: \$002,1)**

Timer A Interrupt Mask (IMTA)	Interrupt Request
0	Timer A interrupt request enabled
1	Timer A interrupt request masked (held pending)

**Timer B interrupt request flag (IFTB: \$002,2):**

The timer B interrupt request flag is set by timer B overflow output (table 9).

**Table 9 Timer B Interrupt Request Flag (IFTB: \$002,2)**

Timer B Interrupt Request Flag (IFTB)	Interrupt Request
0	No timer B interrupt request
1	Timer B interrupt request generated

**Timer B interrupt mask (IMTB: \$002,3):**

This bit masks an interrupt request by the timer B interrupt request flag (table 10).

**Table 10 Timer B Interrupt Mask (IMTB: \$002,3)**

Timer B Interrupt Mask (IMTB)	Interrupt Request
0	Timer B interrupt request enabled
1	Timer B interrupt request masked (held pending)

**Timer C interrupt request flag (IFTC: \$003,0):**

The timer C interrupt request flag is set by timer C overflow output (table 11).

**Table 11 Timer C Interrupt Request Flag (IFTC: \$003,0)**

Timer C Interrupt Request Flag (IFTC)	Interrupt Request
0	No timer C interrupt request
1	Timer C interrupt request generated (held pending)

**Timer C interrupt mask (IMTC: \$003,1):**

This bit masks an interrupt request by the timer C interrupt request flag (table 12).

**Table 12 Timer C Interrupt Mask (IMTC: \$003,1)**

Timer C Interrupt Mask (IMTC)	Interrupt Request
0	Timer C interrupt request enabled
1	Timer C interrupt request masked (held pending)

## HD404889/HD404899/HD404878/HD404868 Series

### Timer D interrupt request flag (IFTD: \$022,2): (Applies to HD404889, HD404899, and HD404878 Series)

The timer D interrupt request flag is set by timer D overflow output, or by an EVND input edge when used as an input capture timer (table 13).

**Table 13** Timer D Interrupt Request Flag (IFTD: \$022,2)

Timer D Interrupt Request Flag (IFTD)	Interrupt Request
0	No timer D interrupt request
1	Timer D interrupt request generated

### Timer D interrupt mask (IMTD: \$022,3): (Applies to HD404889, HD404899, and HD404878 Series)

This bit masks an interrupt request by the timer D interrupt request flag (table 14).

**Table 14** Timer D Interrupt Mask (IMTD: \$022,3)

Timer D Interrupt Mask (IMTD)	Interrupt Request
0	Timer D interrupt request enabled
1	Timer D interrupt request masked (held pending)

### Serial interrupt request flag (IFS: \$023,2):

The serial interrupt request flag is set on completion of serial data transfer, or if data transfer is halted midway (table 15).

**Table 15** Serial Interrupt Request Flag (IFS: \$023,2)

Serial Interrupt Request Flag (IFS)	Interrupt Request
0	No serial interrupt request
1	Serial interrupt request generated

### Serial interrupt mask (IMS: \$023,3):

This bit masks an interrupt request by the serial interrupt request flag (table 16).

**Table 16** Serial Interrupt Mask (IMS: \$023,3)

Serial Interrupt Mask (IMS)	Interrupt Request
0	Serial interrupt request enabled
1	Serial interrupt request masked (held pending)

---

## HD404889/HD404899/HD404878/HD404868 Series

---

### A/D interrupt request flag (IFAD: \$003,2): (Applies to HD404889, HD404899, and HD404868 Series)

The A/D interrupt request flag is set on completion of A/D conversion (table 17).

**Table 17** A/D Interrupt Request Flag (IFAD: \$003,2)

A/D Interrupt Request Flag (IFAD)	Interrupt Request
0	No A/D interrupt request
1	A/D interrupt request generated

### A/D interrupt mask (IMAD: \$003,3): (Applies to HD404889, HD404899, and HD404868 Series)

This bit masks an interrupt request by the A/D interrupt request flag (table 18).

**Table 18** A/D Interrupt Mask (IMAD: \$003,3)

Serial Interrupt Mask (IMAD)	Interrupt Request
0	A/D interrupt request enabled
1	A/D interrupt request masked (held pending)

**Operating Modes**

The five operating modes shown in table 19 can be used for the MCU.

The function of each mode is shown in table 20, and the state transition diagram among each mode in figure 13.

**Table 19 Operating Modes and Clock Status**

		<b>Mode Name</b>				
		<b>Active</b>	<b>Standby</b>	<b>Stop</b>	<b>Watch</b>	<b>Subactive<sup>*2</sup></b>
Activation method		$\overline{\text{RESET}}$ cancellation, interrupt request, $\overline{\text{WU}}_0$ to $\overline{\text{WU}}_3$ input in stop mode STOP/SBY instruction in subactive mode (when direct transfer is selected)	SBY instruction	STOP instruction when TMA3 = 0	STOP instruction when TMA3 = 1	$\overline{\text{INT}}_0$ /timer A or $\overline{\text{WU}}_0$ to $\overline{\text{WU}}_3$ interrupt request in watch mode
Status	System oscillator	OP	OP	Stopped	Stopped	Stopped
	Subsystem oscillator	OP	OP	OP <sup>*1</sup>	OP	OP
Cancellation method		$\overline{\text{RESET}}$ input, STOP/SBY instruction	$\overline{\text{RESET}}$ input, interrupt request	$\overline{\text{RESET}}$ input, $\overline{\text{WU}}_0$ to $\overline{\text{WU}}_3$ input	$\overline{\text{RESET}}$ input, $\overline{\text{INT}}_0$ /timer A or $\overline{\text{WU}}_0$ to $\overline{\text{WU}}_3$ interrupt request	$\overline{\text{RESET}}$ input, STOP/SBY instruction

Notes: OP: implies in operation.

1. Operating or stopping the oscillator can be selected by setting bit 3 of the system clock select register (SSR: \$004)
2. Subactive mode is an optional function; specify it on the function option list.

**Table 20 Operation in Low-Power Dissipation Modes**

<b>Function</b>	<b>Stop Mode</b>	<b>Watch mode</b>	<b>Standby Mode</b>	<b>Subactive Mode<sup>*3</sup></b>
CPU	Retained	Retained	Retained	OP
RAM	Retained	Retained	Retained	OP
Timer A	Stopped	OP	OP	OP
Timer B	Stopped	Stopped	OP	OP
Timer C	Stopped	Stopped	OP	OP
Timer D <sup>*4</sup>	Stopped	Stopped	OP	OP
Serial interface	Stopped <sup>*1</sup>	Stopped <sup>*1</sup>	OP	OP
A/D <sup>*5</sup>	Stopped	Stopped	OP	Stopped
LCD	Stopped	OP <sup>*2</sup>	OP	OP
I/O	Retained	Retained	Retained	OP

Notes: OP: implies in operation.

1. Transmission/Reception is activated if a clock is input in external clock mode. However, interrupts stop.
2. When a 32 kHz clock source is used.
3. Subactive mode is an optional function specified on the function option list.
4. Applies to HD404889, HD404899, and HD404878 Series.
5. Applies to HD404889, HD404899, and HD404868 Series.

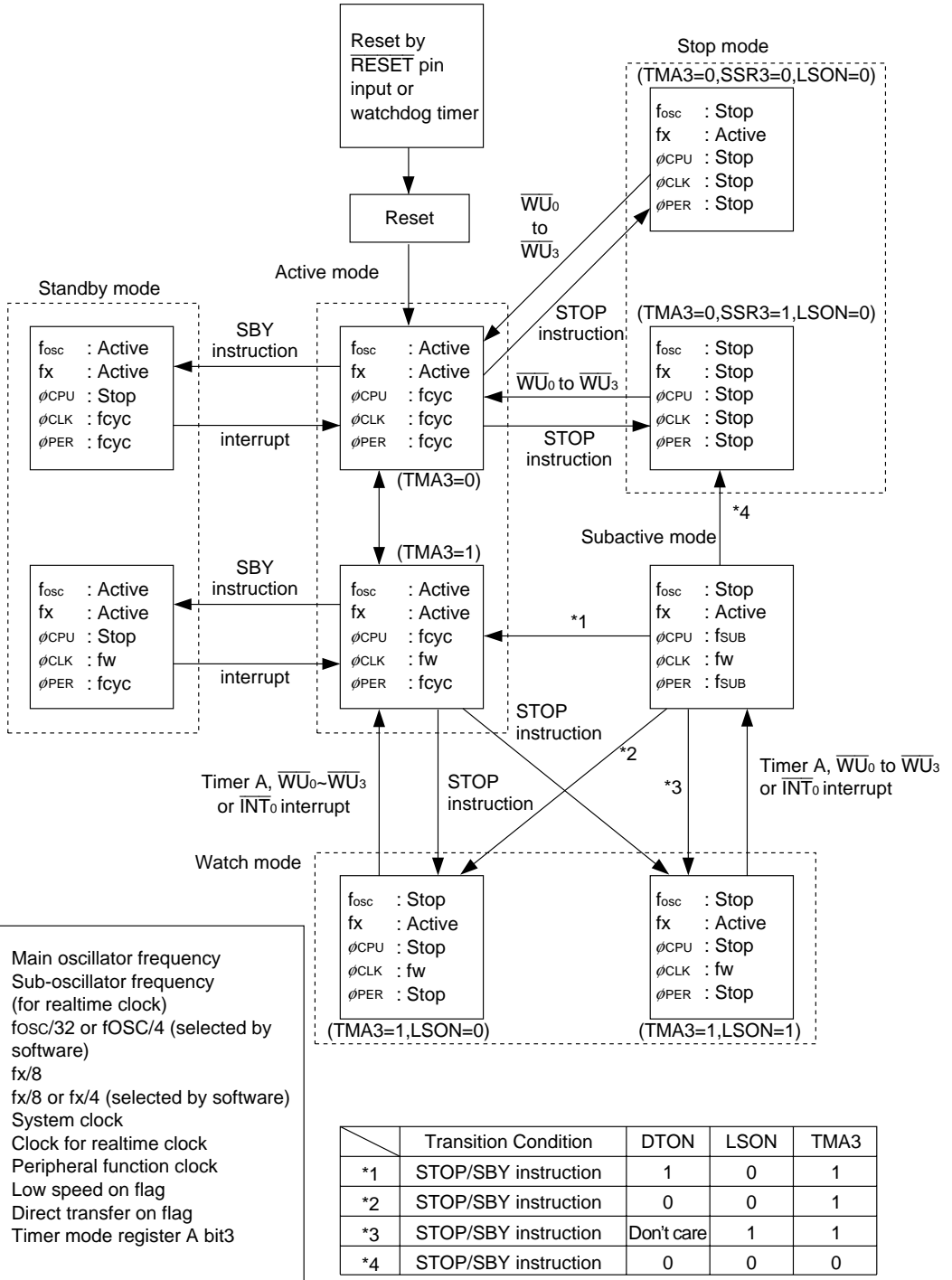


Figure 13 MCU Status Transitions

**Active mode:**

In active mode all functions operate. In this mode, the MCU operates on clocks generated by the OSC<sub>1</sub> and OSC<sub>2</sub> oscillator circuits.

**Standby mode:**

In standby mode the oscillators continue to operate but clocks relating to instruction execution halt. As a result, CPU operation stops, and registers, RAM, and the D port/R port set for output retain their state immediately prior to entering standby mode. Interrupts, timers, the serial interface, and other peripheral functions continue to operate.

Power consumption is lower than in active mode due to the halting of the CPU.

The MCU is switched to standby mode by executing the SBY instruction in active mode. Standby mode is cleared by  $\overline{\text{RESET}}$  input or an interrupt request. When standby mode is cleared by  $\overline{\text{RESET}}$  input, an MCU reset is performed. When standby mode is cleared by an interrupt request, the MCU enters active mode and executes a instruction following the SBY instruction. After executing the instruction, if the interrupt enable flag is set to 1, interrupt handling is executed; if the interrupt enable flag is cleared to 0, the interrupt request is held pending and normal instruction execution is continued.

MCU operation flowchart is shown in figure 14.

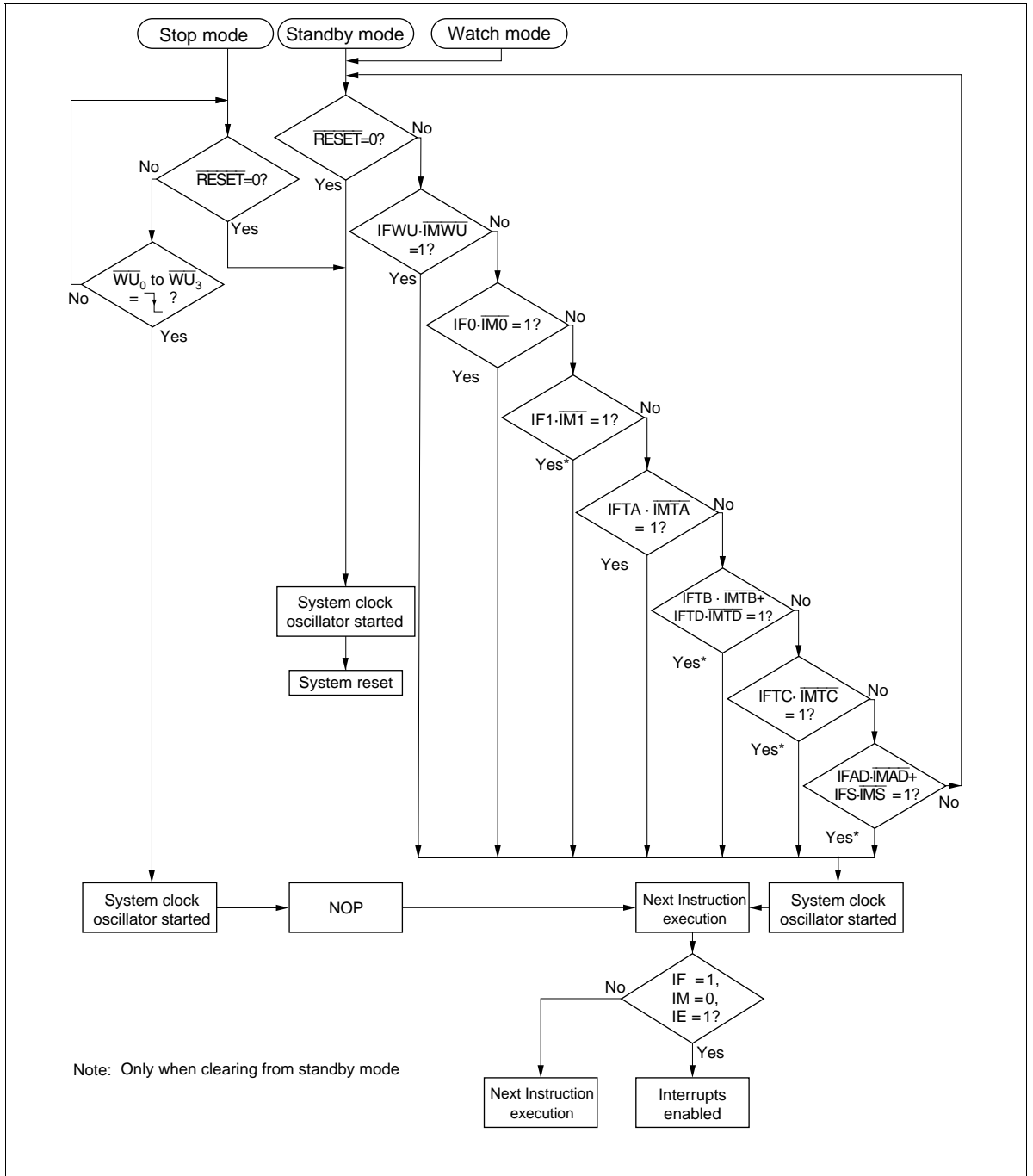


Figure 14 MCU Operation Flowchart

**Stop mode:**

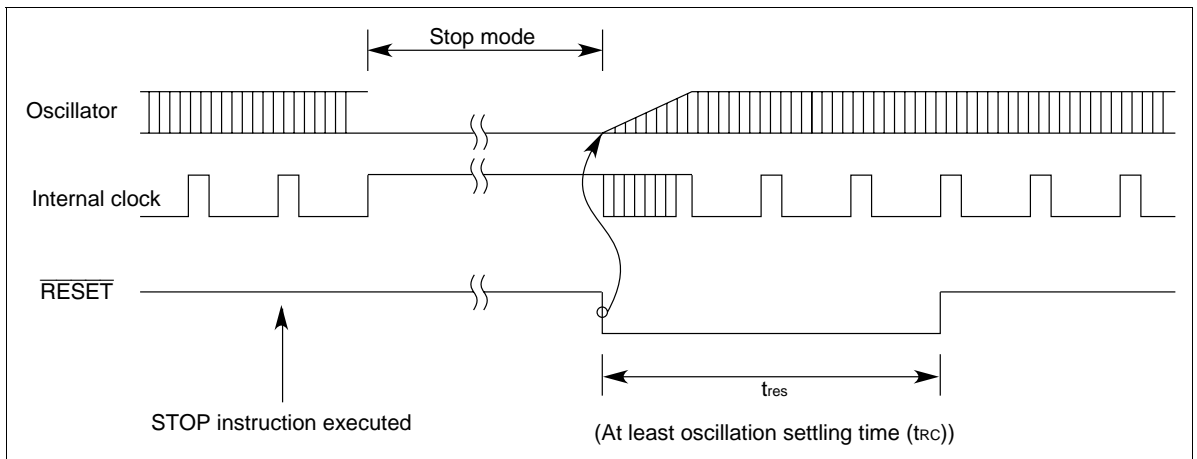
In stop mode, all MCU function stop except that states prior to entry into stop mode are retained. This mode thus has the lowest power consumption of all operating mode.

In stop mode, the OSC<sub>1</sub> and OSC<sub>2</sub> oscillators stop. Bit 3 (SSR3) of the system clock select register (SSR: \$004) (figure 24) can be used to select the active (= 0) or stopped (= 1) state for the X1 and X2 oscillators.

The MCU is switched to stop mode by executing a STOP instruction while bit 3 (TMA3) of timer mode register A (TMA: \$00F) is cleared to 0 in active mode. Stop mode is cleared by  $\overline{\text{RESET}}$  or  $\overline{\text{WU}}_0$  to  $\overline{\text{WU}}_3$  input. When stop mode is cleared by  $\overline{\text{RESET}}$ , the RESET signal should be input for at least the oscillation settling time (trc) (see "AC Characteristics") shown in figure 15. Then, the MCU is initialized and starts instruction execution from the start (address 0) of the program.

When the MCU detects a falling edge at  $\overline{\text{WU}}_0$  to  $\overline{\text{WU}}_3$  in stop mode, it automatically waits for the oscillation settling time, then switches to active mode. After the transition to active mode, the MCU resumes program execution from the instruction following the STOP instruction.

If stop mode is cleared by wakeup input, RAM data and registers retain their values prior to entering stop mode.



**Figure 15 Timing Chart for Clearing Stop Mode by RESET Input**

Note: If stop mode is cleared by wakeup input when an external clock is used as the system clock (OSC1), the subclock should not be stopped in stop mode.

**Watch mode:**

In watch mode, the realtime clock function (timer A) and LCD function using the X1 and X2 oscillators operate, but other functions stop. This mode thus has the second lowest power consumption after stop mode, and is useful for performing realtime clock display only.

In watch mode, the OSC<sub>1</sub> and OSC<sub>2</sub> oscillators stop but the X1 and X2 oscillators continue to operate.

The MCU is switched to watch mode by executing a STOP instruction while TMA3 = 1 in active mode, or by executing a STOP/SBY instruction in subactive mode.

Watch mode is cleared by  $\overline{\text{RESET}}$  input or an  $\overline{\text{INT}}_0$ , timer A or  $\overline{\text{WU}}_0$  to  $\overline{\text{WU}}_3$  interrupt request. For  $\overline{\text{RESET}}$  input, refer to the section on stop mode. When watch mode is cleared by an  $\overline{\text{INT}}_0$ , timer A or  $\overline{\text{WU}}_0$  to  $\overline{\text{WU}}_3$  interrupt request, the mode transition depends on the value of the LSON bit: the MCU enters active mode if LSON = 0, and enters subactive mode if LSON = 1. In the case of a transition to active mode, interrupt request generation is delayed to secure the oscillation settling time: the delay is the tRC set time for the timer A interrupt, and, for the  $\overline{\text{INT}}_0$  interrupt or  $\overline{\text{WU}}_0$  to  $\overline{\text{WU}}_3$  interrupt, Tx ( $T + t_{\text{RC}} < \text{Tx} < 2T + t_{\text{RC}}$ ) if bit 1 and 0 (MIS1, MIS0) of the miscellaneous register are set to 00, or Tx ( $t_{\text{RC}} < \text{Tx} < T + t_{\text{RC}}$ ) if MIS1 and MIS0 are set to 01 or 10 (figures 16 and 17). Other operations when the transition is made are the same as when watch mode is cleared (figure 14).

**Subactive mode:**

In subactive mode, the OSC<sub>1</sub> and OSC<sub>2</sub> oscillator circuits stop and the MCU operates on clocks generated by the X1 and X2 oscillator circuits. In this mode, functions other than the A/D converter operate, but since the operating clocks are slow, power consumption is the lowest after watch mode.

A CPU instruction processing speed of 244  $\mu\text{s}$  or 122  $\mu\text{s}$  can be selected according to whether bit 2 (SSR2) of the system clock select register (SSR: \$004) is set to 1 or cleared to 0. The value of the SSR2 bit should be changed (0→1 or 1→0) only in active mode. If the value is changed in subactive mode, the MCU may operate incorrectly.

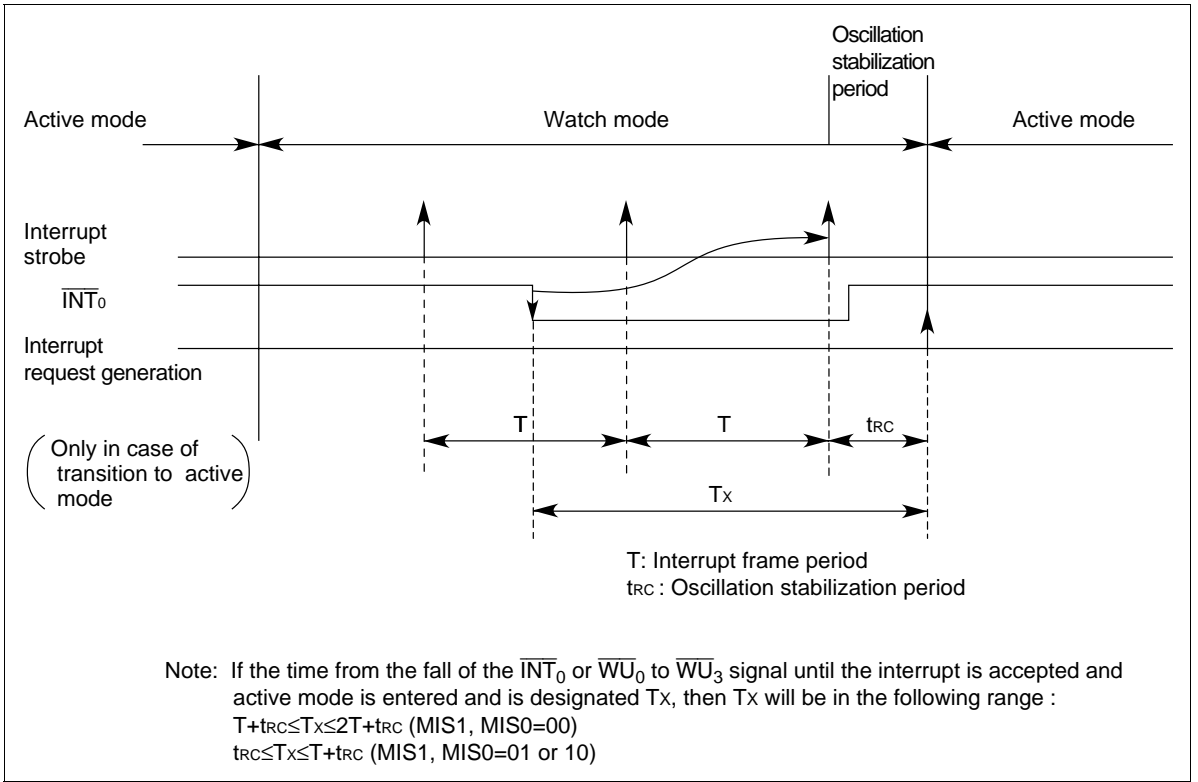
Subactive mode is cleared by executing a STOP/SBY instruction. A transition is then made to either watch mode or active mode according to the value of the low speed on flag (LSON: \$020,0) and the direct transfer on flag (DTON: \$020,3).

Subactive mode is a function option, and should be specified in the function option list.

**Interrupt frame:**

In watch mode and subactive mode,  $\phi_{\text{CLK}}$  is supplied to the timer A,  $\overline{\text{WU}}_0$  to  $\overline{\text{WU}}_3$ , and  $\overline{\text{INT}}_0$  acceptance circuits. Prescaler W and timer A operate as time bases, and generate interrupt frame timing. Either of two values can be selected for the interrupt frame period, T, by means of the miscellaneous register (MIS: \$005) (figure 17).

In watch mode and subactive mode, the timing for generation of timer A,  $\overline{\text{INT}}_0$  and  $\overline{\text{WU}}_0$  to  $\overline{\text{WU}}_3$  interrupts is synchronized with the interrupt frame. Except for the case of an active mode transition, the interrupt strobe timing is used for interrupt request generation. Timer A generates overflow and interrupt requests at the interrupt strobe timing.



**Figure 16 Interrupt Frame**

Miscellaneous Register (MIS: \$005)

Bit	3	2	1	0
Read/Write	W	—	W	W
Reset	0	—	0	0
Bit name	MIS3	—	MIS1	MIS0

MIS1	MIS0	Interrupt Frame period $T_{(ms)} \times 1$	Oscillation Settling Time $trc_{(ms)} \times 1$	Oscillator Circuit Condition
0	0	0.24414	0.12207(0.24414) <sup>+2</sup>	External clock input
	1	3.90625	7.8125	Ceramic resonator
1	0	3.90625	31.25	Crystal resonator
	1	Not used		

Notes: 1. T and trc values are for use of a 32.768 kHz crystal oscillator at the X1-X2 pins.  
 2. This value applies only in case of direct transition operation.

**Figure 17 Miscellaneous Register (MIS)**

## Direct transition from subactive to active mode:

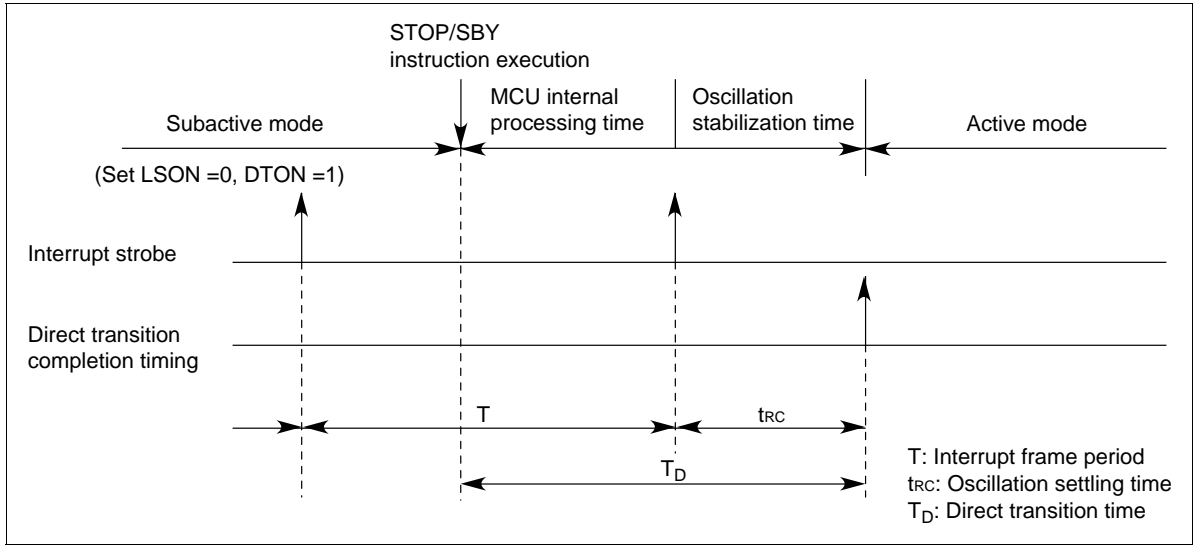
A direct transition can be made from subactive mode to active mode by controlling the direct transfer on flag (DTON: \$020,3) and low speed on flag (LSON: \$020,0). The procedure is shown below.

- (a) Set LSON = 0 and DTON = 1 in subactive mode.
- (b) Execute a STOP or SBY instruction.
- (c) After the lapse of the MCU internal processing time and the oscillation settling time, the MCU automatically switches from subactive mode to active mode (figure 18).

Notes: 1. The DTON flag (\$020,3) can be set in only subactive mode. It is always in the reset state in active mode.

2. The condition for transition time  $T_D$  from the subactive mode to active mode is as follows:

$$t_{RC} < T_D < T + t_{RC}$$

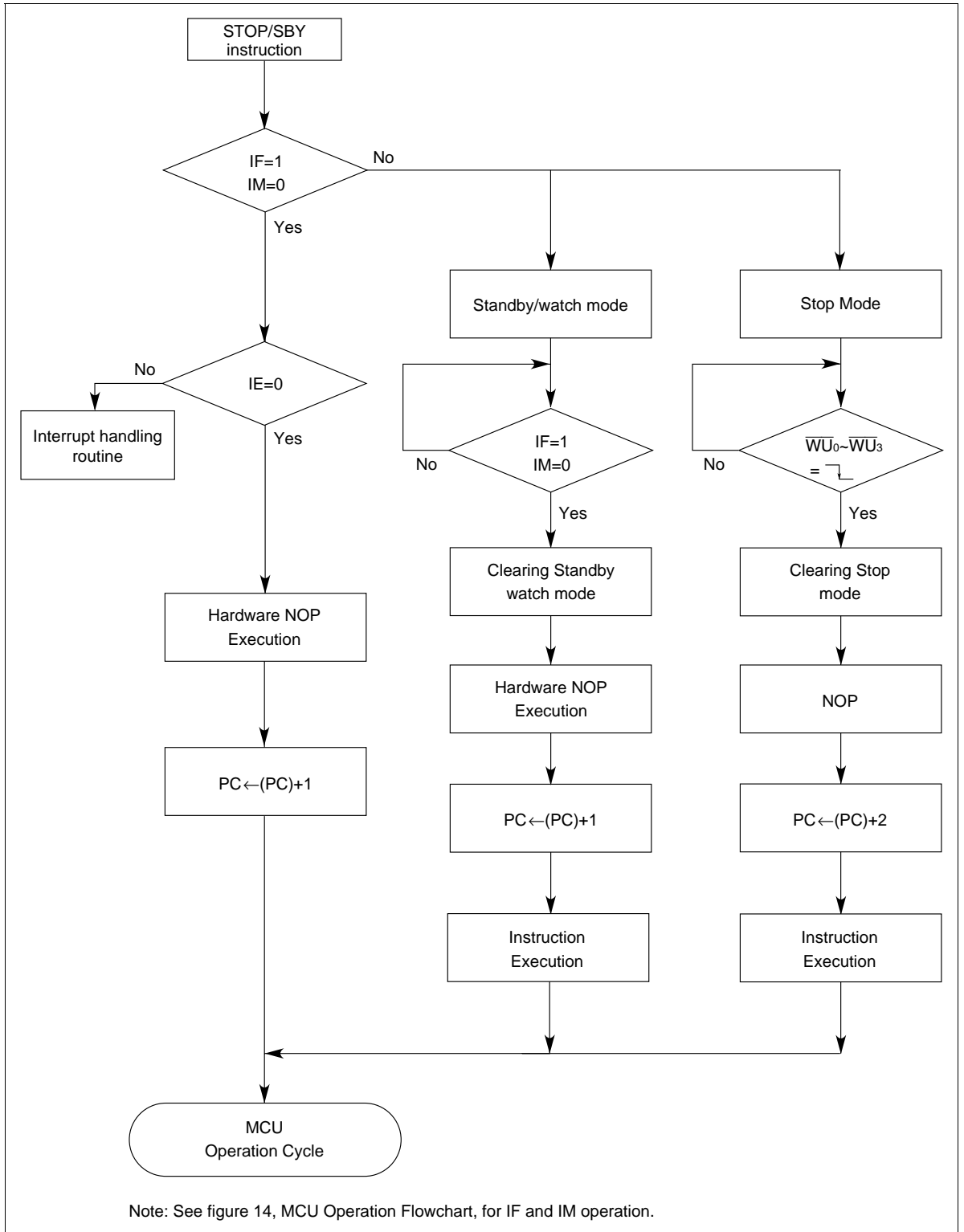


**Figure 18 Direct Transition Timing**

## MCU operation sequence:

The MCU operates in accordance with the flowchart shown in figure 19.  $\overline{RESET}$  input is asynchronous input, and the MCU immediately enters the reset state upon  $\overline{RESET}$  input, regardless of its current state.

In the low-power mode operation sequence, if a STOP/SBY instruction is executed while the IE flag is cleared and the interrupt flag is set, releasing the relevant interrupt mask, the STOP/SBY instruction is canceled (regarded as NOP) and the next instruction is executed. Therefore, when executing a STOP/SBY instruction, all interrupt flags must be cleared, or interrupts masked, beforehand.



Note: See figure 14, MCU Operation Flowchart, for IF and IM operation.

Figure 19 MCU Operating Sequence (Low-Power Mode Operation)

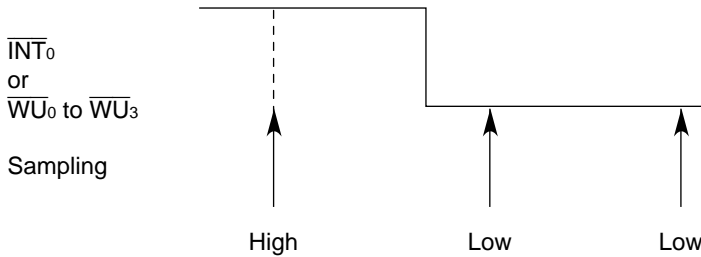
## Usage notes:

In watch mode and subactive mode, an interrupt will not be detected correctly if the  $\overline{\text{INT}}_0$  or  $\overline{\text{WU}}_0$  to  $\overline{\text{WU}}_3$  high or low-level period is shorter than the interrupt frame period.

The MCU's edge sensing method is shown in figure 20. The MCU samples the  $\overline{\text{INT}}_0$  and  $\overline{\text{WU}}_0$  to  $\overline{\text{WU}}_3$  signals at regular intervals, and if consecutive sampled values change from high to low, it determines that a falling edge has been generated.

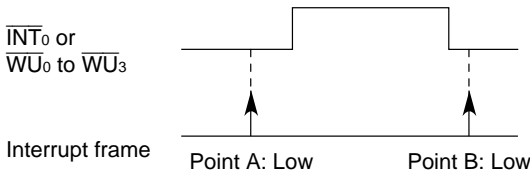
Interrupt detection errors occur since this sampling is performed at the interrupt frame period. If the high-level period of the  $\overline{\text{INT}}_0$  or  $\overline{\text{WU}}_0$  to  $\overline{\text{WU}}_3$  signal is within an interrupt frame, as shown in figure 21 (a), the signal will be low at point A and point B, with the result that the falling edge will not be recognized. Similarly, If the low-level period of the  $\overline{\text{INT}}_0$  or  $\overline{\text{WU}}_0$  to  $\overline{\text{WU}}_3$  signal is within an interrupt frame, as shown in figure 21 (b), the signal will be high at point A and point B, with the result that the falling edge will not be recognized.

In watch mode and subactive mode, therefore, ensure that the high-level and low-level periods of the  $\overline{\text{INT}}_0$  and  $\overline{\text{WU}}_0$  to  $\overline{\text{WU}}_3$  signals is at least as long as the interrupt frame period.

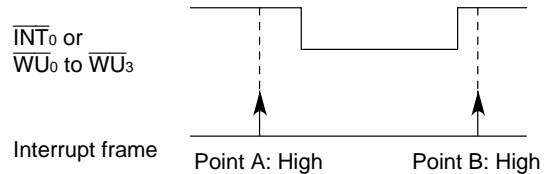


**Figure 20 Edge Sensing Method**

(a) High-level mode



(b) Low-level mode

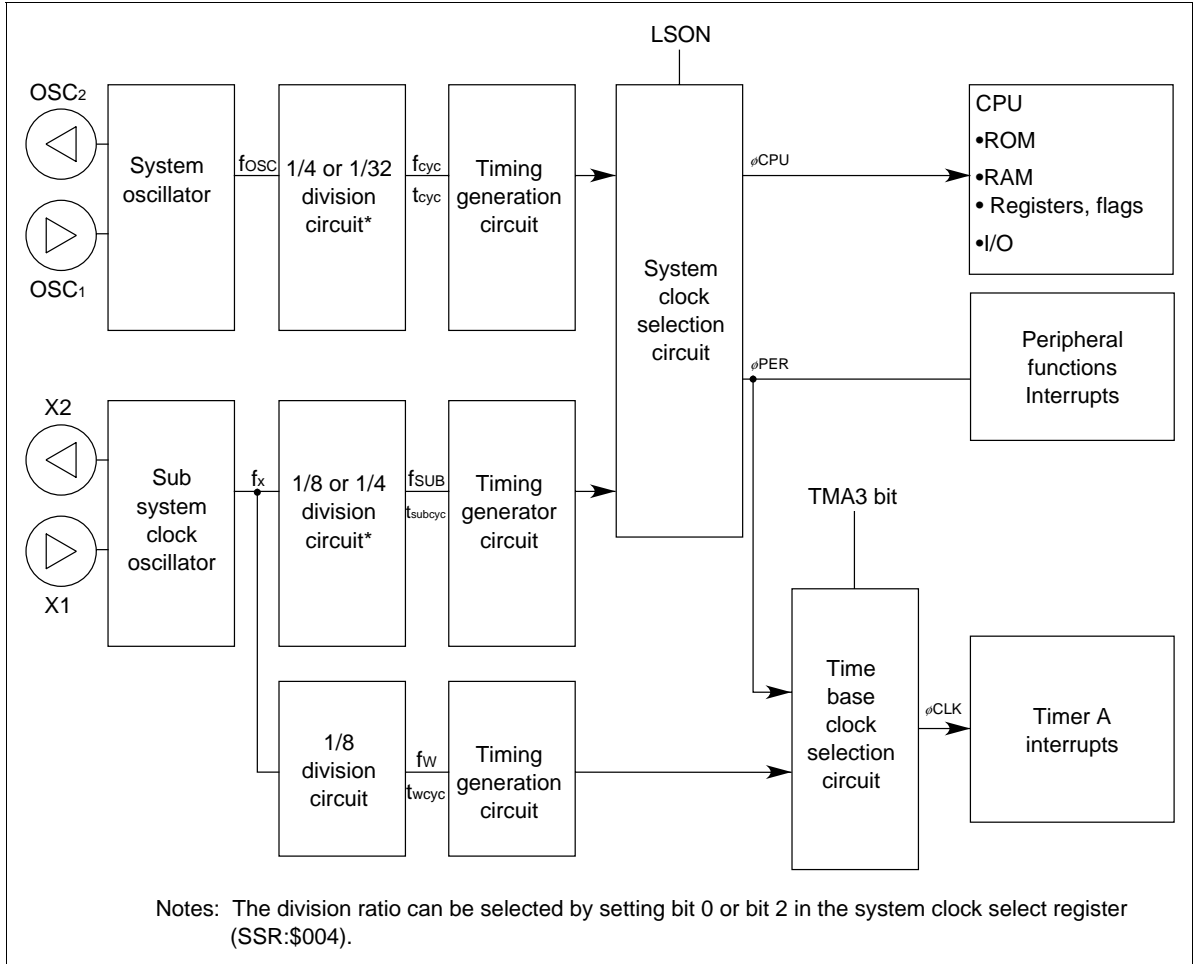


**Figure 21 Sampling Examples**

**Internal Oscillator Circuit**

Figure 22 shows the clock pulse generator circuit. As shown in table 21, a ceramic oscillator or crystal oscillator can be connected to OSC1 and OSC2, and a 32.768 kHz crystal oscillator can be connected to X1 and X2. External clock operation is possible for the system oscillator. Set bit 1 (SSR1) of the system clock select register (SSR: \$004) according to the frequency of the oscillator connected to OSC1 and OSC2 (figure 24).

Note: If the setting of bit 1 in the system clock select register does not match the frequency of the system oscillator, the subsystem using 32.768 kHz oscillation will not operate correctly.



**Figure 22 Clock Pulse Generator Circuit**

## **System Clock Gear Function**

The MCU has a built-in system clock gear function that allows the system clock divided by 4 or by 32 to be selected by software for the instruction execution time. Efficient power consumption can be achieved by operating at the divided-by-4 rate when high-speed processing is needed, and at the divided-by-32 rate at the other times. Figure 23 shows the system clock conversion method.

System clock conversion from division-by-4 to division-by-32 is performed as follows. First, make the division-by-32 setting (SSR0 write), then set the gear enable flag (GEF: \$021,3). This flag is used to distinguish between gear conversion and a transition to standby mode. Next, execute an SBY instruction. When the gear enable flag is not set, standby mode is entered; when this flag is set, gear conversion mode is entered. In this case a transition is made to standby mode for the duration of the gear conversion, but after the synchronization time has elapsed, a transition is made automatically to active mode. As soon as the transition is made to active mode, the gear enable flag is reset.

The same procedure is used for conversion from division-by-32 to division-by-4.

Clear all interrupts, then disable interrupts, before carrying out gear conversion. Incorrect operation may result if an interrupt is generated during gear conversion.

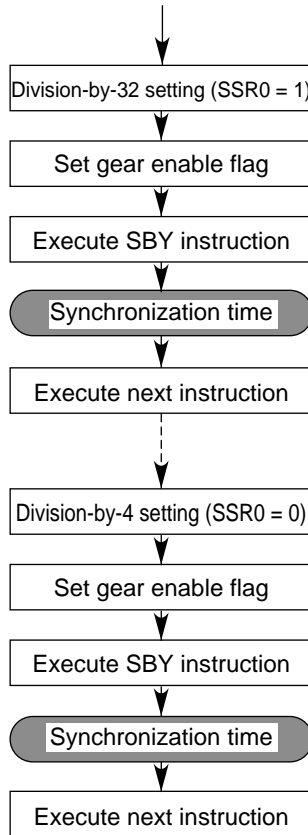
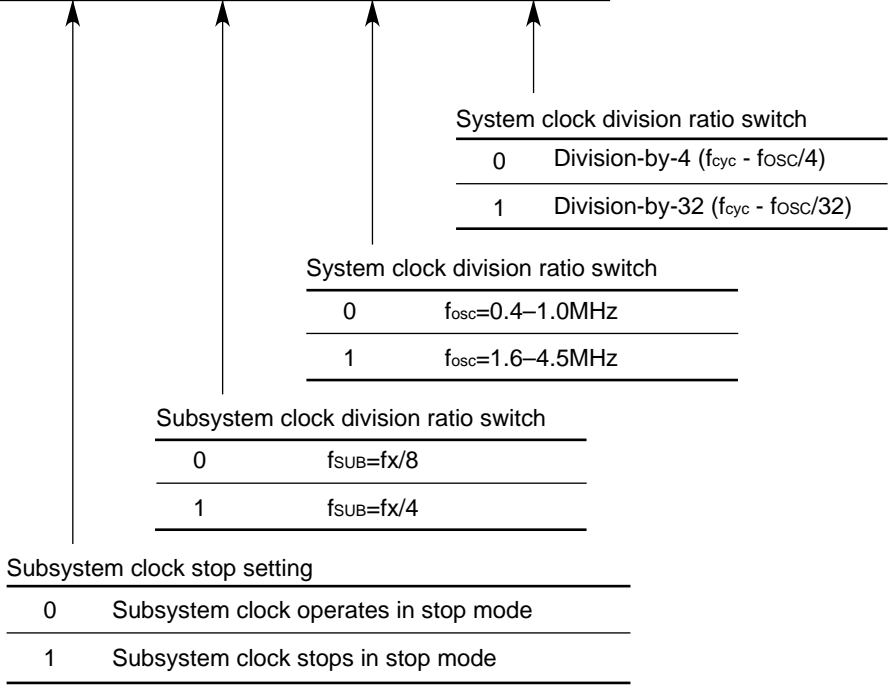


Figure 23 System Clock Division Ratio Conversion Flowchart

## System clock select register (SSR: \$004)

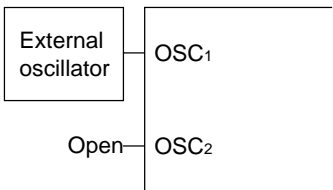
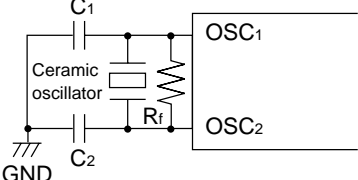
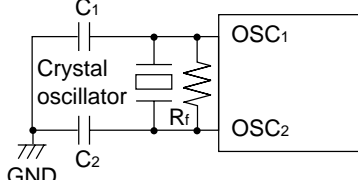
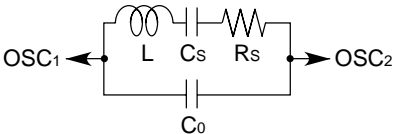
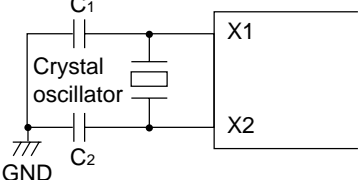
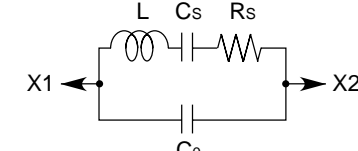
Bit	3	2	1	0
Read/Write	W	W	W	W
Initial value on reset	0	0	0	0
Bit name	SSR3*	SSR2	SSR1	SSR0



Note: \* If the subsystem clock is not used, this bit must be set to 1 following power-on and reset. If it is set to 0 (the initial value), malfunctioning may occur in the stop mode.

**Figure 24 System Clock Select Register**

**Table 21 Oscillator Circuit Examples**

	Circuit Structure	Circuit Constants
External clock operation		
Ceramic oscillator (OSC <sub>1</sub> , OSC <sub>2</sub> )		Ceramic oscillator: CSA4.00MG (Murata)  $R_f = 1M\Omega \pm 20\%$ $C_1 = C_2 = 30pF \pm 20\%$
Crystal oscillator (OSC <sub>1</sub> , OSC <sub>2</sub> )		$R_f = 1M\Omega \pm 20\%$ $C_1 = C_2 = 10\text{--}22pF \pm 20\%$  Crystal: Equivalent circuit at left $C_0 = 7pF_{max.}$ $R_s = 100\Omega_{max.}$
		
Crystal oscillator (X1, X2)		Crystal: 32.768 kHz: MX38T (Nihon Denpa Kogyo) $C_1 = C_2 = 20pF \pm 20\%$ $R_s = 14k\Omega$ $C_0 = 1.5pF$
		

- Notes:
1. With a crystal or ceramic oscillator, circuit constants will differ depending on the resonator, stray capacitance in the interconnecting circuit, and other factors. Suitable constants should be determined in consultation with the resonator manufacturer.
  2. Make the connections between the OSC<sub>1</sub> and OSC<sub>2</sub> pins (X1 and X2 pins) and external components as short as possible, and ensure that no other lines cross these lines (see layout example in figure 25).
  3. When 32.768 kHz crystal oscillation is not used, fix the X1 pin at V<sub>CC</sub> and leave the X2 pin open.

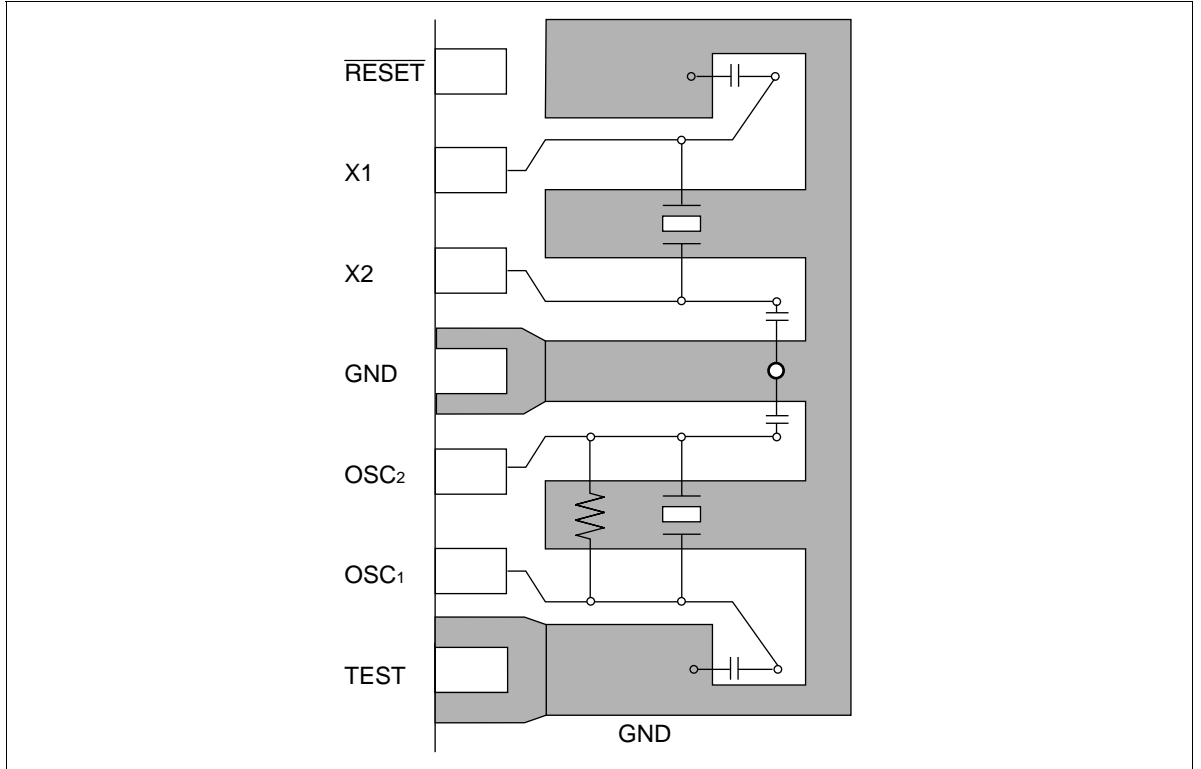


Figure 25 Typical Layouts of Crystal and Ceramic Oscillator

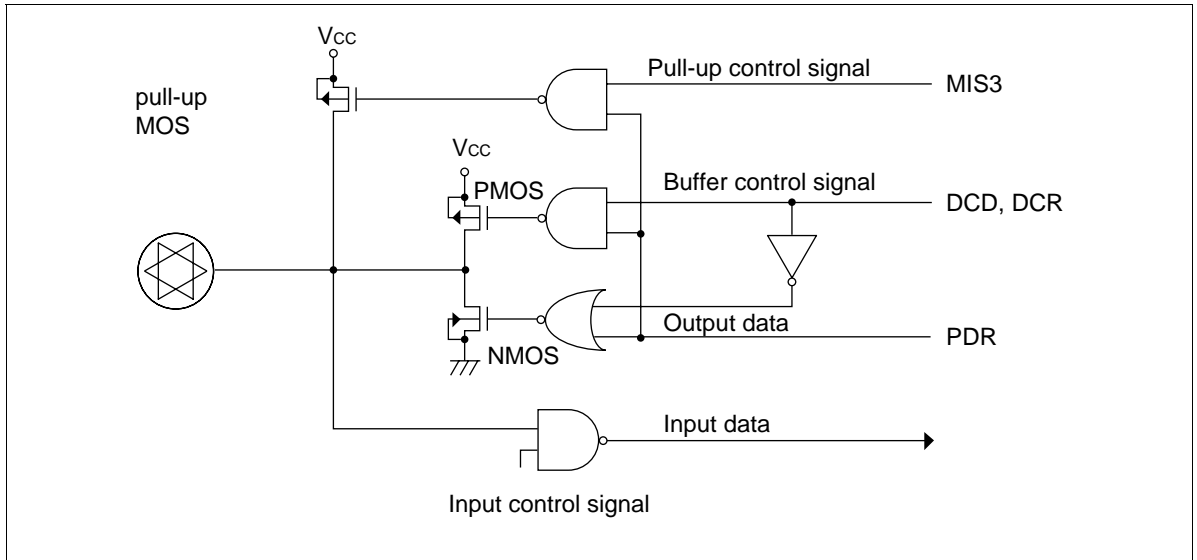
## Input/Output

The MCU has 46 input/output pins ( $D_0$  to  $D_{11}$ ,  $R_0$  to  $R_7$ ,  $R_{8_0}$ , and  $R_{8_1}$ ) in the HD404889, HD404899, and HD404878 Series, or 41 input/output pins ( $D_0$  to  $D_9$ ,  $R_{0_0}$ ,  $R_{0_1}$ ,  $R_{0_2}$ , and  $R_1$  to  $R_7$ ) in the HD404868 Series. The features of these pins are described below.

- The four pins  $D_0$  to  $D_3$  are source large-current (10 mA max.) I/O pins.
- The eight pins  $D_4$  to  $D_{11}$  are sink large-current (15 mA max.) I/O pins.
- I/O pins comprise pins ( $D_0$ ,  $D_1$ ,  $R_0$ ,  $R_1$ ,  $R_2_0$  to  $R_2_2$ ,  $R_3$  to  $R_7$ ,  $R_{8_0}$ , and  $R_{8_1}$ ) that also have a peripheral function (timer, serial interface, etc.). With these pins, the peripheral function setting has priority over the D port or R port pin setting. When a peripheral function setting has been made for a pin, the pin function and input/output mode will be switched automatically in accordance with that setting.
- Selection of input or output for I/O pins, or selection of the port or peripheral function for pins multiplexed as peripheral function pins, is performed by the program.
- All output of the peripheral function pins are CMOS outputs. The SO pin and  $R_2_2$  port pin can be designated as NMOS open-drain output by the program.
- A reset clears peripheral function selection. And since the data control registers (DCD, DCR) are also reset, input/output pins go to the high-impedance state.
- Each I/O pin has a built-in pull-up MOS that can be turned on and off individually by the program.

Figure 26 shows the I/O buffer configuration, and table 22 shows I/O pin circuit configuration control by the program.

Table 23 shows the circuit configuration of each I/O pin.



**Figure 26 I/O Pin Circuit Configuration**

# HD404889/HD404899/HD404878/HD404868 Series

**Table 22 Programmable I/O Circuits**

MIS3 (bit 3 of MIS)		0				1			
DCD,DCR		0		1		0		1	
PDR		0	1	0	1	0	1	0	1
CMOS buffer	PMOS	—	—	—	ON	—	—	—	ON
	NMOS	—	—	ON	—	—	—	ON	—
pull-up MOS		—	—	—	—	—	ON	—	ON

Note: — : OFF

**Table 23 Circuit Configurations of I/O Pins**

Type	Circuit Configuration	Pins
I/O pins		D <sub>0</sub> -D <sub>11</sub> R <sub>0</sub> <sub>0</sub> -R <sub>0</sub> <sub>3</sub> R <sub>1</sub> <sub>0</sub> -R <sub>1</sub> <sub>3</sub> R <sub>2</sub> <sub>0</sub> , R <sub>2</sub> <sub>1</sub> , R <sub>2</sub> <sub>3</sub> R <sub>3</sub> <sub>0</sub> -R <sub>3</sub> <sub>3</sub> R <sub>4</sub> <sub>0</sub> -R <sub>4</sub> <sub>3</sub> R <sub>5</sub> <sub>0</sub> -R <sub>5</sub> <sub>3</sub> R <sub>6</sub> <sub>0</sub> -R <sub>6</sub> <sub>3</sub> R <sub>7</sub> <sub>0</sub> -R <sub>7</sub> <sub>3</sub> R <sub>8</sub> <sub>0</sub> -R <sub>8</sub> <sub>1</sub>
I/O pins		R <sub>2</sub> SMR <sub>22</sub>
Peripheral function pins		SCK

Note: In a reset, since the I/O control registers are reset, input/output pins go to the high-impedance state and peripheral function selections are cleared.

**Table 23** Circuit Configurations of I/O Pins (cont)

Type	Circuit Configuration	Pins
Peripheral function pins		SO
		TOB, TOC, BUZZ
Input pins		RESET
		$\overline{WU_0}$ - $\overline{WU_3}$ , $\overline{INT_0}$ , $\overline{INT_1}$ , EVNB, EVND, SI
		AN <sub>0</sub> -AN <sub>5</sub> *

Notes: In a reset, since the I/O control registers are reset, input/output pins go to the high-impedance state and peripheral function selections are cleared.

\* Applies to HD404889, HD404899, and HD404868 Series.

## D Port

The D port consists of 12 I/O pins (10 I/O pins in the HD404868 Series) that are addressed bit-by-bit.

Ports  $D_0$  to  $D_3$  are source large-current I/O pins, and ports  $D_4$  to  $D_{11}$  (ports  $D_4$  to  $D_9$  in the HD404868 Series) are sink large-current I/O pins.

The D port can be set and reset by the SED and RED instructions or the SEDD and REDD instructions. Output data is stored in the port data register (PDR) for each pin. The entire D port can be tested by the TD or TDD instruction.

The D port output buffer is turned on and off by the D port data control registers (DCD0 to DCD2: \$030 to \$032). The DCD registers are mapped onto memory addresses (figure 27).

Ports  $D_0$  and  $D_1$  are multiplexed as interrupt input pins  $\overline{INT}_0$  and  $INT_1$ , respectively. Setting as interrupt pins is performed by bits 0 and 1 (PMR00, PMR01) of port mode register 0 (PMR0: \$008) (figure 28).

# HD404889/HD404899/HD404878/HD404868 Series

Data control registers (DCD0–2 : \$030–\$032)  
(DCR0–8 : \$034–\$03C)

Register Name	Bit	3	2	1	0
DCD0–DCD2	Read/Write	W	W	W	W
	Reset	0	0	0	0
	Bit name	DCD03–DCD23	DCD02–DCD22	DCD01–DCD21	DCD00–DCD20
DCR0–DCR8	Read/Write	W	W	W	W
	Reset	0	0	0	0
	Bit name	DCR03–DCR73	DCR02–DCR72	DCR01–DCR81	DCR00–DCR80

All bits	CMOS buffer control
0	CMOS buffer off (high impedance)
1	CMOS buffer active

Correspondence between each bit of DCD and DCR and ports

Register Name	Bit 3	Bit 2	Bit 1	Bit 0
DCD0	D <sub>3</sub>	D <sub>2</sub>	D <sub>1</sub>	D <sub>0</sub>
DCD1	D <sub>7</sub>	D <sub>6</sub>	D <sub>5</sub>	D <sub>4</sub>
DCD2	D <sub>11</sub> *	D <sub>10</sub> *	D <sub>9</sub>	D <sub>8</sub>
DCR0	R <sub>03</sub> *	R <sub>02</sub>	R <sub>01</sub>	R <sub>00</sub>
DCR1	R <sub>13</sub>	R <sub>12</sub>	R <sub>11</sub>	R <sub>10</sub>
DCR2	R <sub>23</sub>	R <sub>22</sub>	R <sub>21</sub>	R <sub>20</sub>
DCR3	R <sub>33</sub>	R <sub>32</sub>	R <sub>31</sub>	R <sub>30</sub>
DCR4	R <sub>43</sub>	R <sub>42</sub>	R <sub>41</sub>	R <sub>40</sub>
DCR5	R <sub>53</sub>	R <sub>52</sub>	R <sub>51</sub>	R <sub>50</sub>
DCR6	R <sub>63</sub>	R <sub>62</sub>	R <sub>61</sub>	R <sub>60</sub>
DCR7	R <sub>73</sub>	R <sub>72</sub>	R <sub>71</sub>	R <sub>70</sub>
DCR8	—	—	R <sub>81</sub> *	R <sub>80</sub> *

Note: \* Applies to HD404889, HD404899, and HD404878 Series

**Figure 27 Data Control Registers (DCD, DCR)**

## R Port

The R port consists of 34 I/O pins (31 I/O pins in the HD404868 Series) that are addressed in 4-bit units.

Input can be performed by means of the LAR and LBR instructions, and output by means of the LRA and LRB instructions. Output data is stored in the port data register (PDR) for each pin.

The R port output buffer is turned on and off by the R port data control registers (DCR0 to DCR8: \$034 to \$03C). The DCR registers are mapped onto memory addresses (figure 27).

Ports R0<sub>0</sub> to R0<sub>3</sub> are multiplexed as wakeup input pins  $\overline{WU}_0$  to  $\overline{WU}_3$ , respectively. Setting of these pins as peripheral function pins is performed by port mode register 1 (PMR1: \$009) (figure 29).

Ports R1<sub>0</sub> and R1<sub>1</sub> are multiplexed as peripheral function pins EVNB and EVND, respectively. Setting of these pins as peripheral function pins is performed by bits 0 and 1 (PMR20, PMR21) of port mode register 2 (PMR2: \$00A) (figure 30).

Ports R1<sub>2</sub> to R1<sub>3</sub> and R2<sub>0</sub> are multiplexed as peripheral function pins BUZZ, TOB, and TOC, respectively. Setting of these pins as peripheral function pins is performed by bits 2 and 3 (PMR22, PMR23) of port mode register 2 (PMR2: \$00A) and bit 0 (PMR30) of port mode register 3 (PMR3: \$00B)(figures 30 and 31).

Ports R2<sub>1</sub> and R2<sub>2</sub> are multiplexed as peripheral function pins  $\overline{SCK}$  and SI/SO, respectively. Setting of these pins as peripheral function pins is performed by bits 1 to 3 (PMR31 to PMR33) of port mode register 3 (PMR3: \$00B) (figure 31).

Ports R3 to R6 are multiplexed as peripheral function pins SEG1 to SEG16, respectively. Setting of these pins as segment pins is performed every 4 pins in 4-bit units by port mode register 4 (PMR4: \$00C) (figure 32).

Ports R7<sub>0</sub> to R7<sub>3</sub> and R8<sub>0</sub> to R8<sub>1</sub> also function as peripheral function pins AN<sub>0</sub> to AN<sub>5</sub> (HD404889, HD404899, and HD404868 series only). Peripheral function pin setting of these pins is performed using bits 1 to 3 (AMR<sub>1</sub> to AMR<sub>3</sub>) of the A/D mode register (AMR :\$028). (See Figure 74 in A/D Converter.)

Port mode register 0 (PMR0: \$008)

Bit	3	2	1	0
Read/Write	—	—	W	W
Initial value on reset	—	—	0	0
Bit name	Not used	Not used	PMR01	PMR00

PMR00	D <sub>0</sub> /INT <sub>0</sub> pin mode selection
0	D <sub>0</sub>
1	INT <sub>0</sub>

PMR01	D <sub>1</sub> /INT <sub>1</sub> pin mode selection
0	D <sub>1</sub>
1	INT <sub>1</sub>

**Figure 28 Port Mode Register 0 (PMR0: \$008)**

# HD404889/HD404899/HD404878/HD404868 Series

Port mode register 1 (PMR1: \$009)

Bit	3	2	1	0
Read/Write	W	W	W	W
Initial value on reset	0	0	0	0
Bit name	PMR13*	PMR12	PMR11	PMR10

PMR10	R0 $\overline{WU}_0$ pin mode selection
0	R0 $\overline{0}$
1	$\overline{WU}_0$

PMR11	R0 $\overline{1WU}_1$ pin mode selection
0	R0 $\overline{1}$
1	$\overline{WU}_1$

PMR12	R0 $\overline{2WU}_2$ pin mode selection
0	R0 $\overline{2}$
1	$\overline{WU}_2$

PMR13	R0 $\overline{3WU}_3$ pin mode selection
0	R0 $\overline{3}$
1	$\overline{WU}_3$

Note: \* Applies to HD404889, HD404899, and HD404878 Series

Figure 29 Port Mode Register 1 (PMR1: \$009)

Port mode register 2 (PMR2: \$00A)

Bit	3	2	1	0
Read/Write	W	W	W	W
Initial value on reset	0	0	0	0
Bit name	PMR23	PMR22	PMR21*	PMR20

↑

PMR23	R13/TOB pin mode selection
0	R13
1	TOB

↑

PMR22	R12/BUZZ pin mode selection
0	R12
1	BUZZ

↑

PMR21	R11/EVND pin mode selection
0	R11
1	EVND

↑

PMR20	R10/EVNB pin mode selection
0	R10
1	EVNB

Note: \* Applies to HD404889, HD404899, and HD404878 Series

**Figure 30 Port Mode Register 2 (PMR2: \$00A)**

Port mode register 3 (PMR3: \$00B)

Bit	3	2	1	0
Read/Write	W	W	W	W
Initial value on reset	0	0	0	0
Bit name	PMR33	PMR32	PMR31	PMR30

PMR30	R2 <sub>0</sub> /TOC pin mode selection
0	R2 <sub>0</sub>
1	TOC

PMR31	R2 <sub>1</sub> /SCK pin mode selection
0	R2 <sub>1</sub>
1	SCK

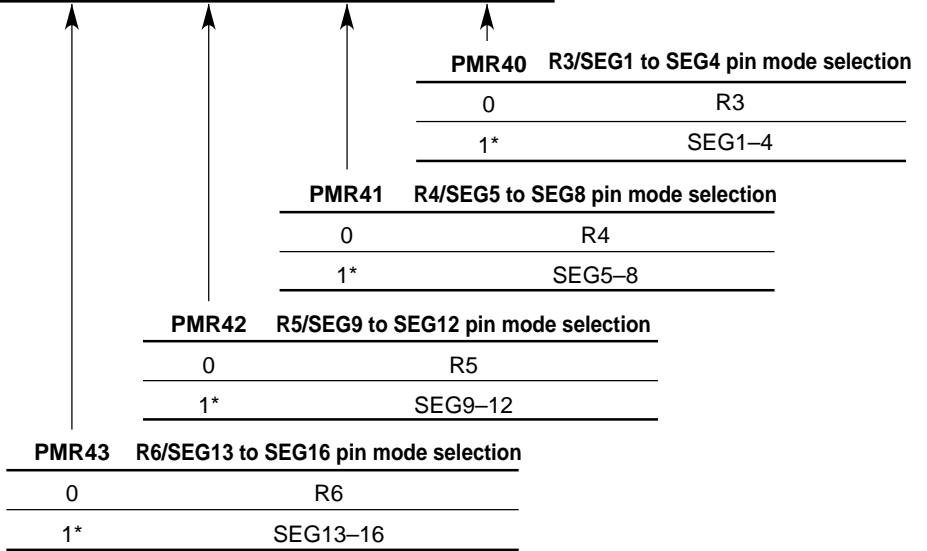
PMR33	PMR32	R2 <sub>2</sub> /SI/SO pin mode selection
0	*	R2 <sub>2</sub>
1	0	SI
	1	SO

\* : Don't care

Figure 31 Port Mode Register 3 (PMR3: \$00B)

Port mode register 4 (PMR4: \$00C)

Bit	3	2	1	0
Read/Write	W	W	W	W
Initial value on reset	0	0	0	0
Bit name	PMR43	PMR42	PMR41	PMR40



\* : When use as a segment output pin, write its port data register (PDR) to '0'

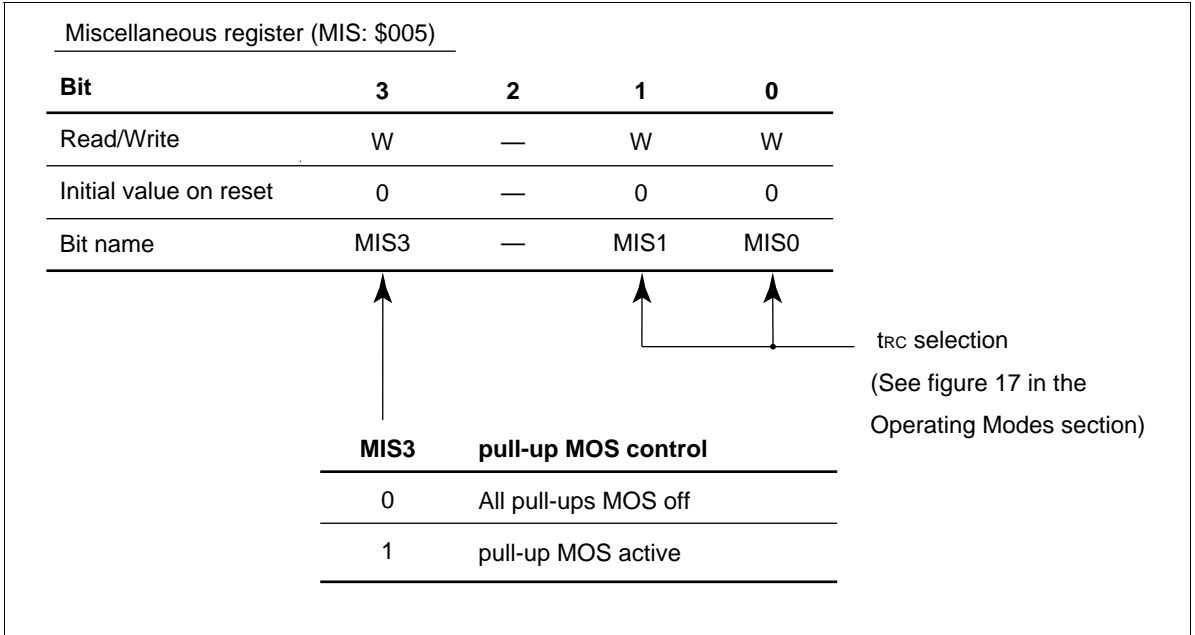
**Figure 32 Port Mode Register 4 (PMR4: \$00C)**

**Pull-Up MOS Control**

Program-controllable pull-ups MOS are incorporated in all I/O pins.

On/off control of all pull-ups MOS is performed by bit 3 (MIS3) of the miscellaneous register (MIS: \$005) and the port data register (PDR) for each pin, enabling the pull-up MOS to be turned on or off independently for each pin (table 22, figure 33).

Except for analog input multiplexed pins, the pull-up MOS on/off setting can be made independent of the setting as an on-chip supporting module pin.



**Figure 33 Miscellaneous Register (MIS:\$005)**

**Handling of I/O Pins Not Used by User System**

If I/O pins that are not used by the user system are left floating, they may generate noise that can result in chip malfunctions. Therefore, the pin potential must be fixed.

In this case, pull the pins up to  $V_{CC}$  with the built-in pull-up MOS or with an external resistor of approximately 100 k $\Omega$ .

## Prescalers

The MCU has the following two prescalers, S and W.

The operating conditions for each prescaler are shown in table 24, and the output supply destinations in figure 34.

Timer A to D input clocks other than external events, serial transfer clocks other than external clocks, and the LCD circuit operating clock are selected from the prescaler outputs in accordance with the respective mode register.

### Prescaler Operation

#### Prescaler S (PSS):

Prescaler S is an 11-bit counter that has the system clock as input. When the MCU is reset, prescaler S is reset to \$000, then divides the system clock. Prescaler S operation is stopped by a reset by the MCU, and in stop mode and watch mode. It does not stop in any other modes.

#### Prescaler W (PSW):

Prescaler W is a counter that has a clock divided from the X1 input (32 kHz crystal oscillation) as input.

When the MCU is reset, prescaler W is reset to \$00, then divides the input clock. Prescaler W can also be reset by software.

**Table 24 Prescaler Operating Conditions**

Prescaler	Input Clock	Reset Conditions	Stop Conditions
Prescaler S	System clock in active and standby modes, Subsystem clock in subactive mode	MCU reset, Stop mode clearance	MCU reset, Stop mode, Watch mode
Prescaler W	Clock obtained by division-by-8 of 32.768 kHz oscillation by subsystem clock oscillator	MCU reset, Software*	MCU reset, Stop mode

Note: If bits TMA3 to TMA1 in timer mode register A (TMA) are all set to 1, PSW is cleared to \$00.

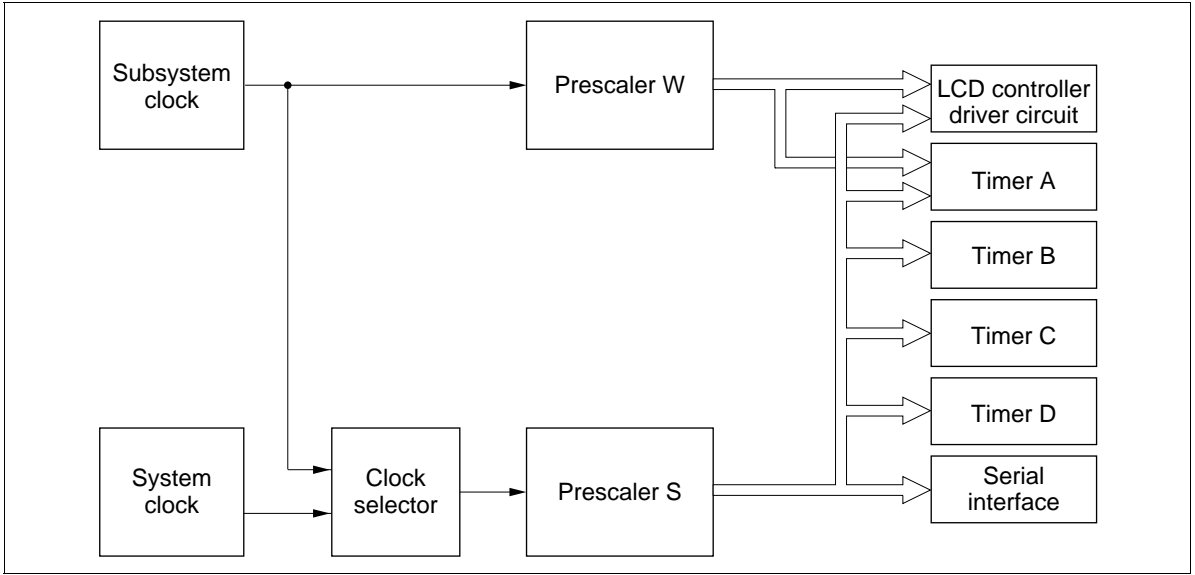


Figure 34 Prescaler Output Destinations

## Timers

The MCU incorporates four timers, A to D, in the HD404889, HD404899, and HD404878 Series, or three timers, A to C, in the HD404868 Series.

- Timer A: Free-running timer
- Timer B: Multifunctional timer
- Timer C: Multifunctional timer
- Timer D: Multifunctional timer

Timer A is an 8-bit free-running timer. Timers B, C, and D are 8-bit multifunctional timers; Each one of their have the functions shown in table 25 and their operating mode can be set by the program.

**Table 25 Timer Functions**

Funcios		Timer A	Timer B	Timer C	Timer D
Clock source	Prescaler S	Available	Available	Available	Available
	Prescaler W	Available	—	—	—
	External event	—	Available	—	Available
Timer functions	Free-running	Available	Available	Available	Available
	Time-base	Available	—	—	—
	Event counter	—	Available	—	Available
	Reload	—	Available	Available	Available
	Watchdog	—	—	Available	—
	Input Capture	—	—	—	Available
Timer outputs	Toggle	—	Available	Available	—
	PWM	—	Available	Available	—

Note: — implies not available

## Timer A

### Timer A Functions

Timer A has the following functions.

- Free-running timer
- Realtime clock time base

The block diagram of timer A is shown in figure 35.

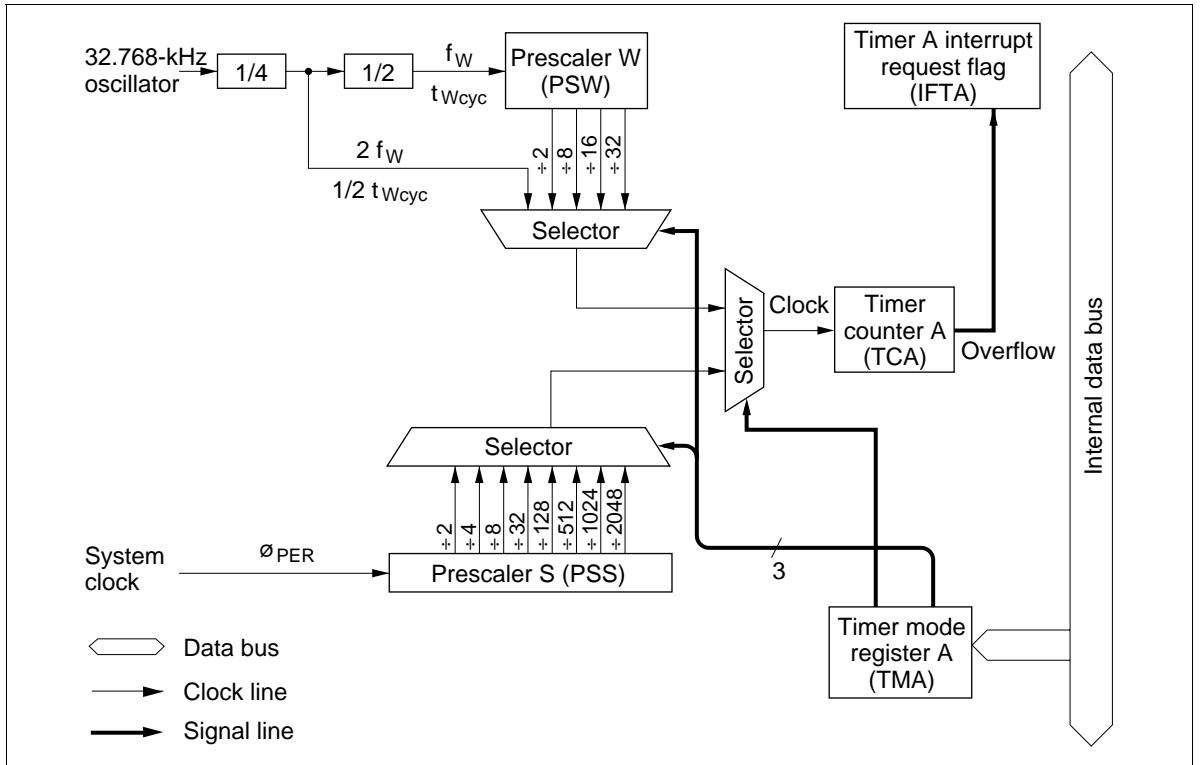


Figure 35 Timer A Block Diagram

## Timer A Operation

### Free-running timer operation:

The timer A input clock is selected by timer mode register A (TMA: \$00F).

Timer A is reset to \$00 by an MCU reset, and counts up each time the input clock is input. When the input clock is input after the timer A value reaches \$FF, overflow output is generated, and the timer A value becomes \$00. The generated overflow output sets the timer A interrupt request flag (IFTA: \$002,0). Timer A continues counting up after the count value returns to \$00, so that an interrupt is generated regularly every 256 input clock cycles.

### Realtime clock time base operation:

Timer A can be used as the realtime clock time base by setting bit 3 (TMA3) of timer mode register A to 1. As the prescaler W output is input to timer/counter A, interrupts are generated with accurate timing using the 32.768 kHz crystal oscillator as the basic clock.

When timer A is used as the realtime clock time base, prescaler W and timer/counter A can be reset to \$00 by the program.

## **Timer A Register**

Timer A operation is set by means of the following register.

### **Timer mode register A (TMA: \$00F):**

Timer mode register A (TMA: \$00F) is a 4-bit write-only register. Timer A operation and input clock selection are set as shown in figure 36.

# HD404889/HD404899/HD404878/HD404868 Series

Timer mode register A (TMA: \$00F)

Bit	3	2	1	0
Read/Write	W	W	W	W
Initial value on reset	0	0	0	0
Bit name	TMA3	TMA2	TMA1	TMA0

TMA3	TMA2	TMA1	TMA0	Source prescaler	Input clock period	Operating mode
		0	0	PSS	2,048 $t_{cyc}$	Timer A mode
		1	0	PSS	1,024 $t_{cyc}$	
	0	0	0	PSS	512 $t_{cyc}$	
	0	1	0	PSS	128 $t_{cyc}$	
	0	1	1	PSS	32 $t_{cyc}$	
	1	0	0	PSS	8 $t_{cyc}$	
	1	0	1	PSS	4 $t_{cyc}$	
	1	1	1	PSS	2 $t_{cyc}$	
		0	0	PSW	32 $t_{wycyc}$	Time base mode
		1	0	PSW	16 $t_{wycyc}$	
	0	0	0	PSW	8 $t_{wycyc}$	
	0	1	0	PSW	2 $t_{wycyc}$	
	1	0	1	PSW	1/2 $t_{wycyc}$	
	1	1	1	Not Used		
		1	*	PSW, TCA reset		

\* : Don't care

- Notes:
1.  $t_{wycyc} = 244.14 \mu s$  (using 32.768 kHz crystal oscillator)
  2. Timer/counter overflow output period (s) = input clock period (s)  $\times$  256.
  3. If PSW and TCA reset is selected during LCD, the LCD enters the halt state (power switch off). Therefore, to provide continuous LCD the PSW and TCA reset interval must be minimized by the program.
  4. The division ratio must not be changed while time base mode is being used, as this will result in an error in the overflow period.

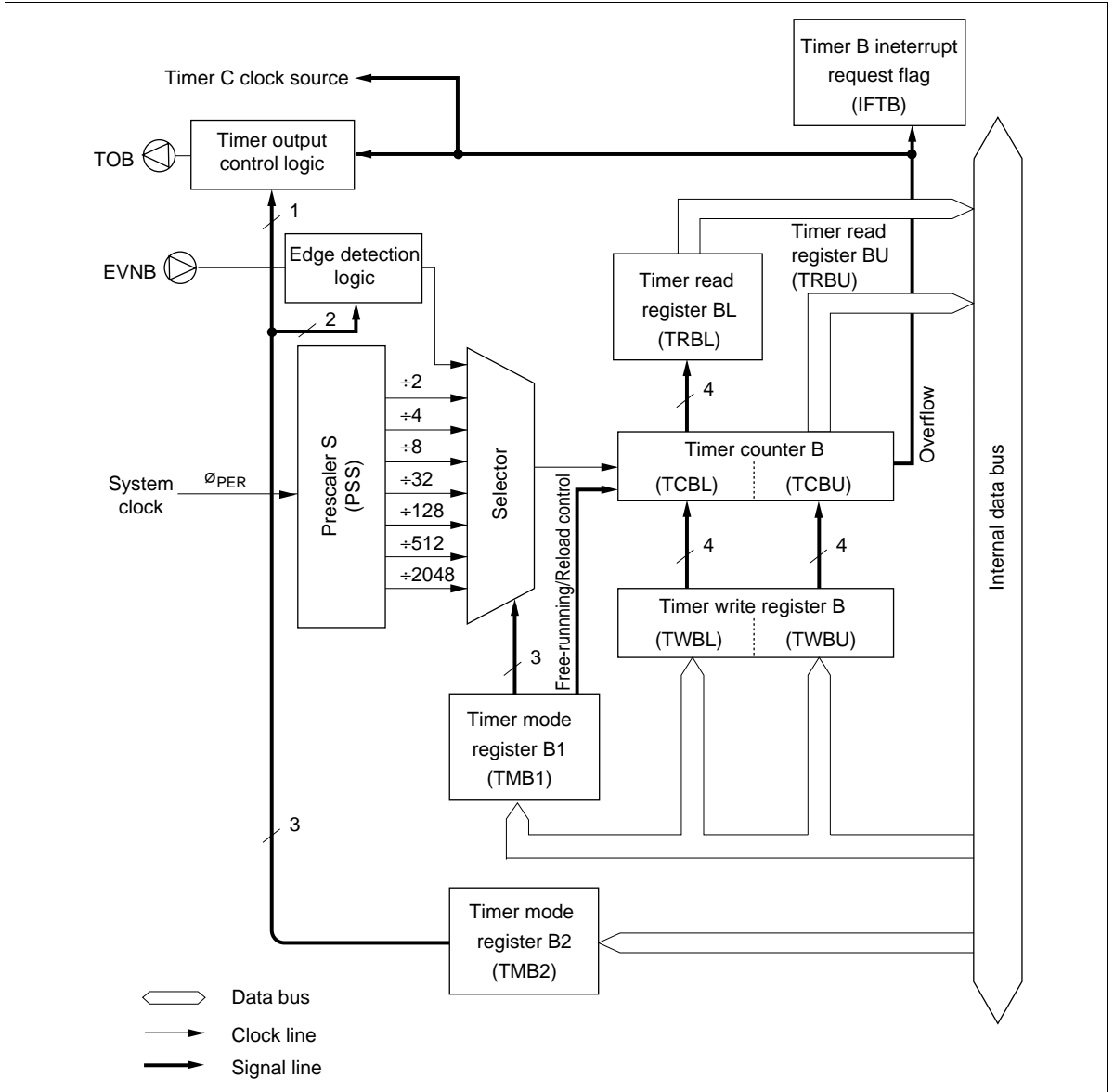
Figure 36 Timer Mode Register A (TMA)

**Timer B**

**Timer B Functions:** Timer B has the following functions.

- Free-running/reload timer
- External event counter
- Timer output operation (toggle output, PWM output)

The block diagram of timer B is shown in figure 37.



**Figure 37 Timer B Block Diagram**

## Timer B Operation

- Free-running/reload timer:

Free-running/reload timer operation, the input clock source, and the prescaler division ratio are selected by means of timer mode register B1 (TMB1).

Timer B is initialized to the value written to timer write register B (TWBL, TWBU) by software, and counts up by 1 each time the input clock is input. When the input clock is input after the timer B value reaches \$FF, overflow output is generated. Timer B is then set to the value in timer write register B if the reload timer function is selected, or to \$00 if the free-running timer function is selected, and starts counting up again.

Overflow output sets the timer B interrupt request flag (IFTB). This flag is reset by the program or by an MCU reset.

For details, see figure 3, Interrupt Control Bit and Register Flag Area Configuration, and table 1, Initial Values after MCU Reset.

- External event counter operation:

When external event input is designated for the input clock, timer B operates as an external event counter. When external event input is used, the R1<sub>0</sub>/EVNB pin is designated as the EVNB pin by port mode register 2 (PMR2).

The external event detected edge for timer B can be designated as a falling edge, rising edge, or both falling and rising edges in the input signal by means of timer mode register B2 (TMB2). If both falling and rising edges are selected, the input signal falling and rising edge interval should be at least 2tcyc.

Timer B counts up by 1 each time a falling edge is detected in the signal input at the EVNB pin. Other operations are the same as for the free-running/reload timer function.

- Timer output operation:

With timer B, the R13/TOB pin is designated as the TOB pin by the setting of bit 3 of port mode register 2 (PMR2), and toggle waveform output or PWM waveform output can be selected by timer mode register B2 (TMB2).

— Toggle output:

With toggle output, the output level is changed upon input of the next clock pulse after the timer B value reaches \$FF. Use of this function in combination with the reload timer allows a clock signal with any period to be output, enabling it to be used as buzzer output. The output waveform is shown in figure 38 (1).

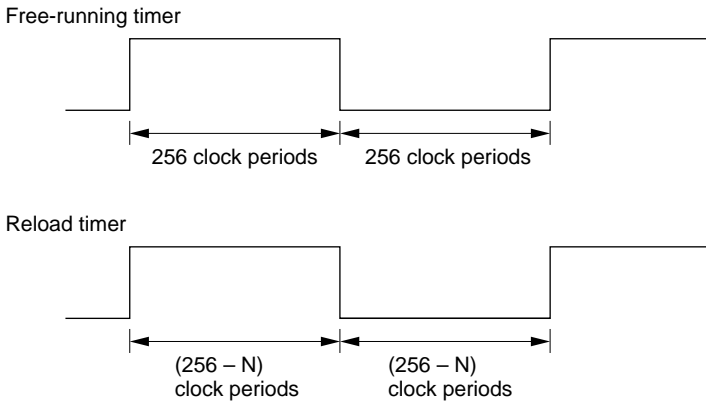
— PWM output:

With PWM output, variable-duty pulses are output. The output waveform is as shown in figure 38 (2), according to the contents of timer mode register B1 (TMB1) and timer write register B (TWBL, TWBU). When the waveform is output with bit 3 (TMB13) of timer mode register B1 cleared to 0, the write to timer write register B to change the duty is effective from the next frame, whereas if the waveform is output with the TMB13 bit set to 1 (reload setting), the next frame is output immediately after the timer write register write.

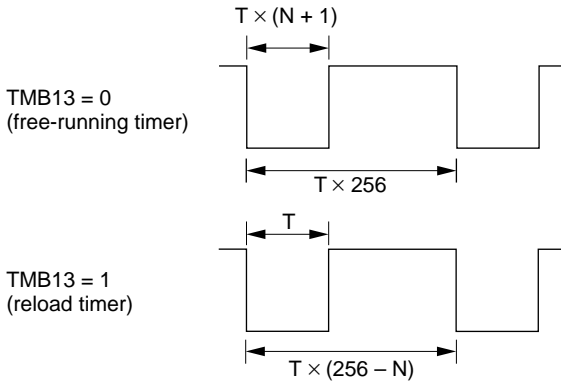
- Module standby:

With timer B, the supply of the system clock to the timer/counter can be halted by setting bit 0 of module standby register 1 (MSR1: \$00D) to 1. In the module standby state, the mode register value is retained but the counter value is not guaranteed.

(1) Toggle output waveform (timer B, timer C)



(2) PWM output waveform (timer B, timer C)



Notes: T: Counter input clock period  
 (The clock input source and division ratio are controlled by timer mode register B1 and timer mode register C1.)  
 N: Value in timer write register B or timer write register C  
 When N = 255 (= \$FF), PWM output is always fixed at the timer low level.)

**Figure 38 Timer Output Waveforms**

## Timer B Registers

Timer B operation setting and timer B value reading/writing is controlled by the following registers.

Timer mode register B1 (TMB1: \$010)

Timer mode register B2 (TMB2: \$011)

Timer write register B (TWBL: \$012, TWBU: \$013)

Timer read register B (TRBL: \$012, TRBU: \$013)

Port mode register 2 (PMR2: \$00A)

Module standby register 1 (MSR1: \$00D)

- **Timer mode register B1 (TMB1: \$010):**

Timer mode register B1 (TMB1) is a 4-bit write-only register, used to select free-running/reload timer operation and the input clock as shown in figure 39.

Timer mode register B1 (TMB1) is reset to \$0 by an MCU reset:

A modification of timer mode register B1 (TMB1) becomes effective after execution of two instructions following the timer mode register B1 (TMB1) write instruction. The program must provide for timer B initialization by writing to timer write register B (TWBL, TWBU) to be executed after the post-modification mode has become effective.

Timer mode register B1 (TMB1: \$010)

Bit	3	2	1	0
Read/Write	W	W	W	W
Initial value on reset	0	0	0	0
Bit name	TMB13	TMB12	TMB11	TMB10

				Input clock period and input clock source
TMB12	TMB11	TMB10		
0	0	0	2,048 $t_{cyc}$	
		1	512 $t_{cyc}$	
	1	0	128 $t_{cyc}$	
		1	32 $t_{cyc}$	
1	0	0	8 $t_{cyc}$	
		1	4 $t_{cyc}$	
	1	0	2 $t_{cyc}$	
		1	R10/EVNB (external event input)	

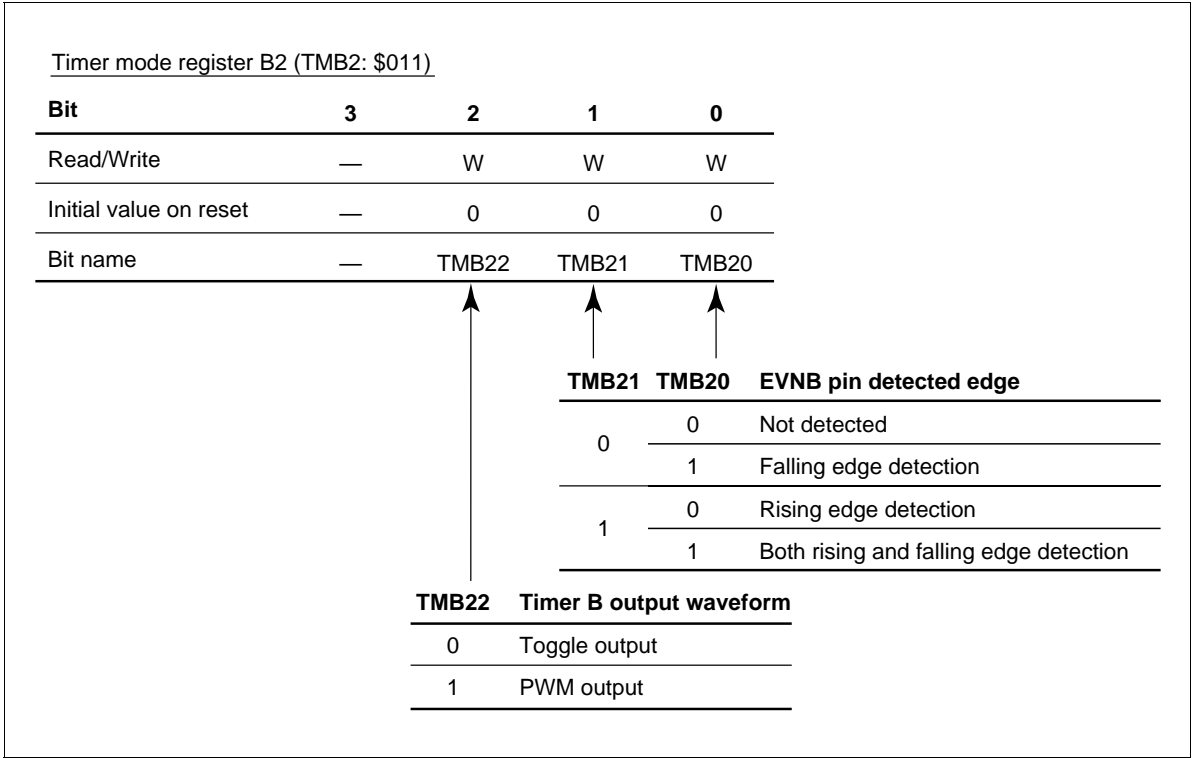
TMB13	Free-running/reload timer
0	Free-running timer
1	Reload timer

**Figure 39 Timer Mode Register B1 (TMB1)**

- Timer mode register B2 (TMB2: \$011):

Timer mode register B2 (TMB2) is a 3-bit write-only register, used to select the timer B output mode and EVNB pin detected edge as shown in figure 40.

Timer mode register B2 (TMB2) is reset to \$0 by an MCU reset.



**Figure 40 Timer Mode Register B2 (TMB2)**

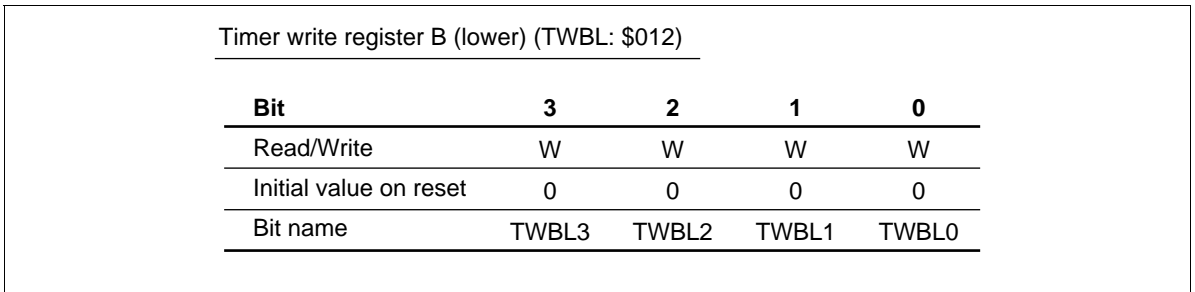
- Timer write register B (TWBL: \$012, TWBU:\$013):

Timer write register B (TWBL, TWBU) is a write-only register composed of a lower digit (TWBL) and an upper digit (TWBU) (figures 41 and 42).

The lower digit (TWBL) of timer write register B is reset to \$0 by an MCU reset, while the upper digit (TWBU) is undetermined.

Timer B can be initialized by writing to timer write register B (TWBL, TWBU). To write the data, first write the lower digit (TWBL). The lower digit write does not change the timer B value. Next, write the upper digit (TWBU). Timer B is then initialized to the timer write register B (TWBL, TWBU) value.

When writing to timer write register B (TWBL, TWBU) from the second time onward, if it is not necessary to change the lower digit (TWBL) reload value, timer B initialization is completed by the upper digit write alone.



**Figure 41 Timer Write Register B (Lower) (TWBL)**

Timer write register B (upper) (TWBU: \$013)

Bit	3	2	1	0
Read/Write	W	W	W	W
Initial value on reset	Undetermined	Undetermined	Undetermined	Undetermined
Bit name	TWBU3	TWBU2	TWBU1	TWBU0

**Figure 42 Timer Write Register B (Upper) (TWBU)**

- Timer read register B (TRBL: \$012, TRBU: \$013):

Timer read register B (TRBL, TRBU) is a read-only register composed of a lower digit (TRBL) and an upper digit (TRBU) from which the value of the upper digit of timer B is read directly (figures 43 and 44).

First, read the upper digit (TRBU) of timer read register B. The current value of the timer B upper digit is read and, at the same time, the value of the timer B lower digit is latched in the lower digit (TRBL) of timer read register B. The timer B value is obtained when the upper digit (TRBU) of timer read register B is read by reading the lower digit (TRBL) of timer read register B.

Timer read register B (lower) (TRBL: \$012)

Bit	3	2	1	0
Read/Write	R	R	R	R
Initial value on reset	Undetermined	Undetermined	Undetermined	Undetermined
Bit name	TRBL3	TRBL2	TRBL1	TRBL0

**Figure 43 Timer Read Register B (Lower) (TRBL)**

Timer read register B (upper) (TRBU: \$013)

Bit	3	2	1	0
Read/Write	R	R	R	R
Initial value on reset	Undetermined	Undetermined	Undetermined	Undetermined
Bit name	TRBU3	TRBU2	TRBU1	TRBU0

**Figure 44 Timer Read Register B (Upper) (TRBU)**

# HD404889/HD404899/HD404878/HD404868 Series

- Port mode register 2 (PMR2: \$00A):

Port mode register 2 (PMR2) is a write-only register used to set the function of the R1<sub>0</sub>/EVNB and R1<sub>3</sub>/TOB pins as shown in figure 45.

Port mode register 2 (PMR2) is reset to \$0 by an MCU reset.

## Port mode register 2 (PMR2: \$00A)

Bit	3	2	1	0
Read/Write	W	W	W	W
Initial value on reset	0	0	0	0
Bit name	PMR23	PMR22	PMR21*	PMR20

PMR20	R1 <sub>0</sub> /EVNB pin mode selection
0	R1 <sub>0</sub>
1	EVNB

PMR21	R1 <sub>1</sub> /EVND pin mode selection
0	R1 <sub>1</sub>
1	EVND

PMR22	R1 <sub>2</sub> /BUZZ pin mode selection
0	R1 <sub>2</sub>
1	BUZZ

PMR23	R1 <sub>3</sub> /TOB pin mode selection
0	R1 <sub>3</sub>
1	TOB

Note: \* Applies to HD404889, HD404899, and HD404878 Series

**Figure 45 Port Mode Register 2 (PMR2: \$00A)**

- Module standby register 1 (MSR1: \$00D):

Module standby register 1 (MSR1) is a write-only register used to designate supply or stopping of the clock to timer B as shown in figure 46.

Module standby register 1 (MSR1) is reset to \$0 by an MCU reset.

Module standby register 1 (MSR1: \$00D)

Bit	3	2	1	0
Read/Write	—	W	W	W
Initial value on reset	—	0	0	0
Bit name	—	MSR12	MSR11	MSR10

MSR10	Timer B clock supply control
0	Supplied
1	Stopped

MSR11	Timer C clock supply control
0	Supplied
1	Stopped

MSR12	Timer D clock supply control
0	Supplied
1	Stopped

**Figure 46 Module Standby Register 1 (MSR1)**

## Timer C

**Timer C Functions:** Timer C has the following functions.

- Free-running/reload timer
- Watchdog timer
- Timer output operation (toggle output, PWM output)

The block diagram of timer C is shown in figure 47.

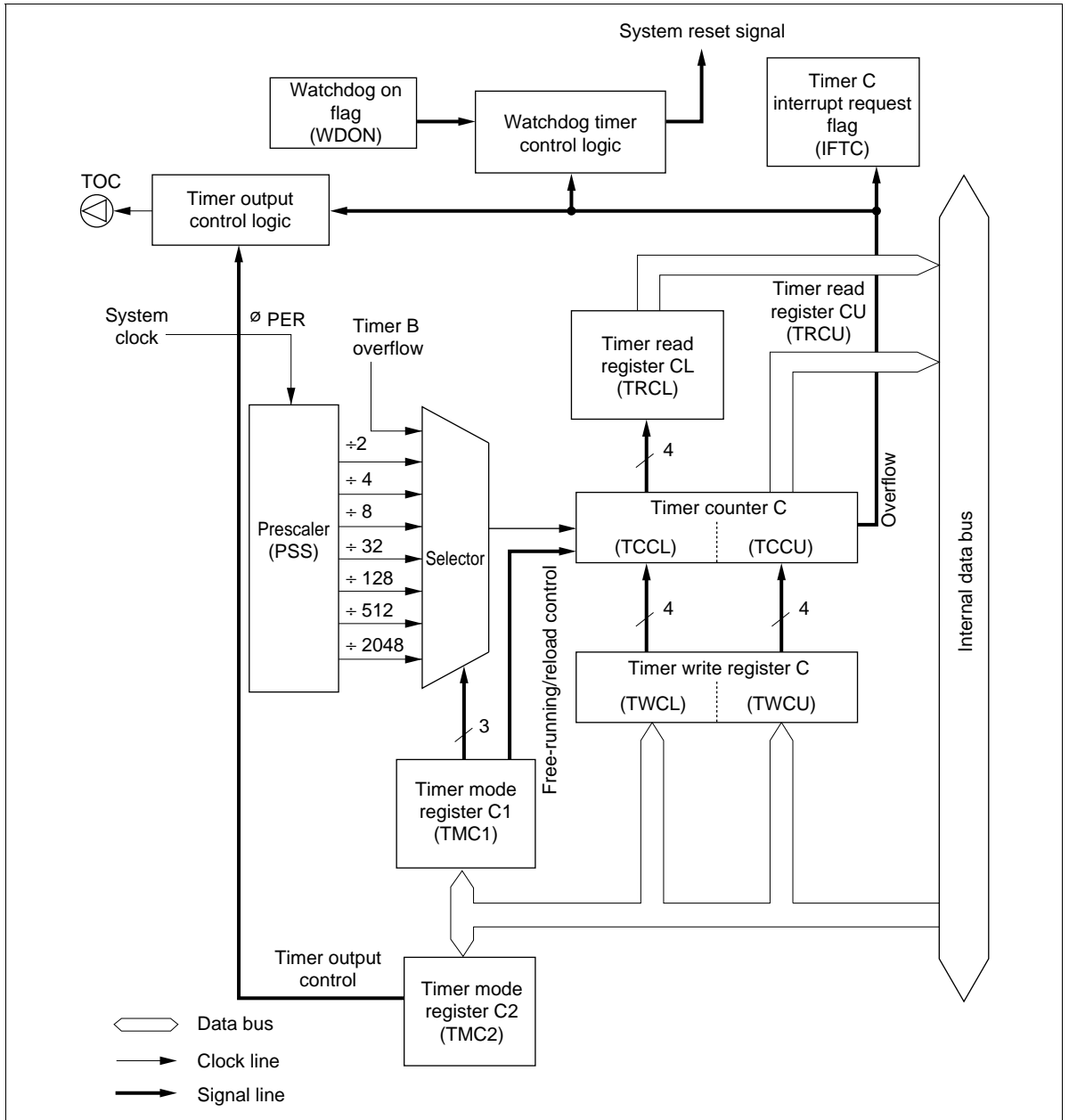


Figure 47 Timer C Block Diagram

## Timer C Operation

- Free-running/reload timer:

Free-running/reload timer operation, the input clock source, and the prescaler division ratio are selected by means of timer mode register C1 (TMC1).

Timer C is initialized to the value written to timer write register C (TWCL, TWCU) by software, and counts up by 1 each time the input clock is input. When the input clock is input after the timer C value reaches \$FF, overflow output is generated. Timer C is then set to the value in timer write register C (TWCL, TWCU) if the reload timer function is selected, or to \$00 if the free-running timer function is selected, and starts counting up again.

Overflow output sets the timer C interrupt request flag (IFTC). This flag is reset by the program or by an MCU reset.

For details, see figure 3, Interrupt Control Bit and Register Flag Area Configuration, and table 1, Initial Values after MCU Reset.
- 16-bit timer operation:

When timer B overflow flag is selected as the clock source, timer C can be used as a 16-bit timer that counts the timer B clock source pulses. In this case, since the timer B and timer C free-running/reload settings are independent, the settings should be made to suit the purpose.
- Watchdog timer operation:

By using the timer C overflow output, timer C can be used as a watchdog timer for detecting program runaway. The watchdog timer is enabled when the watchdog on flag (WDON) is set to 1, and generates an MCU reset when timer C overflows. Usually, timer C initialization is performed by the program before the timer C value reaches \$FF, so controlling program runaway.
- Timer output operation:

With timer C, the R2<sub>0</sub>/TOC pin is designated as the TOC pin by setting bit 0 of port mode register 3 (PMR3) to 1, and toggle waveform output or PWM waveform output can be selected by timer mode register C2 (TMC2).

  - Toggle output  
The operation is similar to that for timer B toggle output.
  - PWM output  
The operation is similar to that for timer B PWM output.
- Module standby:

The operation is similar to that for timer B module standby.

## Timer C Registers

Timer C operation setting and timer C value reading/writing is controlled by the following registers.

Timer mode register C1 (TMC1: \$014)

Timer mode register C2 (TMC2: \$015)

Timer write register C (TWCL: \$016, TWCU: \$017)

Timer read register C (TRCL: \$016, TRCU: \$017)

Port mode register 3 (PMR3: \$00B)

Module standby register 1 (MSR1: \$00D)

- Timer mode register C1 (TMC1: \$014):

Timer mode register C1 (TMC1) is a 4-bit write-only register, used to select free-running/reload timer operation, the input clock, and the prescaler division ratio as shown in figure 48.

Timer mode register C1 (TMC1) is reset to \$0 by an MCU reset.

A modification of timer mode register C1 (TMC1) becomes effective after execution of two instructions following the timer mode register C1 (TMC1) write instruction. The program must provide for timer C initialization by writing to timer write register C (TWCL, TWCU) to be executed after the post-modification mode has become effective.

Timer mode register C1 (TMC1: \$014)

Bit	3	2	1	0
Read/Write	W	W	W	W
Initial value on reset	0	0	0	0
Bit name	TMC13	TMC12	TMC11	TMC10

	TMC12	TMC11	TMC10	Input clock period
0	0	0	0	2,048 $t_{cyc}$
		1	1	512 $t_{cyc}$
	1	0	0	128 $t_{cyc}$
		1	1	32 $t_{cyc}$
1	0	0	0	8 $t_{cyc}$
		1	1	4 $t_{cyc}$
	1	0	0	2 $t_{cyc}$
		1	1	Timer B overflow

TMC13	Free-running/reload timer
0	Free-running timer
1	Reload timer


**Figure 48 Timer Mode Register C1 (TMC1)**

- Timer mode register C2 (TMC2: \$015):

Timer mode register C2 (TMC2) is a 1-bit write-only register, used to select the timer C output mode as shown in figure 49.

Timer mode register C2 (TMC2) is reset to \$0 by an MCU reset.

Timer mode register C2 (TMC2: \$015)				
Bit	3	2	1	0
Read/Write	—	W	—	—
Initial value on reset	—	0	—	—
Bit name	—	TMC22	—	—



TMC22	Timer C output waveform
0	Toggle output
1	PWM output

**Figure 49 Timer Mode Register C2 (TMC2)**

- Timer write register C (TWCL: \$016, TWCU: \$017):

Timer write register C (TWCL, TWCU) is a write-only register composed of a lower digit (TWCL) and an upper digit (TWCU) (figures 50 and 51).

Timer write register C (TWCL, TWCU) operation is similar to that for timer write register B (TWBL, TWBU).

Timer write register C (lower) (TWCL: \$016)				
Bit	3	2	1	0
Read/Write	W	W	W	W
Initial value on reset	0	0	0	0
Bit name	TWCL3	TWCL2	TWCL1	TWCL0

**Figure 50 Timer Write Register C (Lower) (TWCL)**

Timer write register C (upper) (TWCU: \$017)

Bit	3	2	1	0
Read/Write	W	W	W	W
Initial value on reset	Undetermined	Undetermined	Undetermined	Undetermined
Bit name	TWCU3	TWCU2	TWCU1	TWCU0

**Figure 51 Timer Write Register C (Upper) (TWCU)**

- Timer read register C (TRCL: \$016, TRCU: \$017):

Timer read register C (TRCL, TRCU) is a read-only register composed of a lower digit (TRCL) and an upper digit (TRCU) from which the value of the upper digit of timer C is read directly (figures 52 and 53).

Timer read register C (TRCL, TRCU) operation is similar to that for timer read register B (TRBL, TRBU).

Timer read register C (lower) (TRCL: \$016)

Bit	3	2	1	0
Read/Write	R	R	R	R
Initial value on reset	Undetermined	Undetermined	Undetermined	Undetermined
Bit name	TRCL3	TRCL2	TRCL1	TRCL0

**Figure 52 Timer Read Register C (Lower) (TRCL)**

Timer read register C (upper) (TRCU: \$017)

Bit	3	2	1	0
Read/Write	R	R	R	R
Initial value on reset	Undetermined	Undetermined	Undetermined	Undetermined
Bit name	TRCU3	TRCU2	TRCU1	TRCU0

**Figure 53 Timer Read Register C (Upper) (TRCU)**

- Port mode register 3 (PMR3: \$00B):

Port mode register 3 (PMR3) is a write-only register used to set the function of the R2<sub>0</sub>/TOC pin as shown in figure 54.

Port mode register 3 (PMR3) is reset to \$0 by an MCU reset.

Port mode register 3 (PMR3: \$00B)

Bit	3	2	1	0
Read/Write	W	W	W	W
Initial value on reset	0	0	0	0
Bit name	PMR33	PMR32	PMR31	PMR30

	↑	↑	↑	↑													
					<table border="1" style="margin-left: auto; margin-right: auto;"> <thead> <tr> <th style="text-align: left;">PMR30</th> <th style="text-align: left;">R2<sub>0</sub>/TOC pin mode selection</th> </tr> </thead> <tbody> <tr> <td style="text-align: center;">0</td> <td style="text-align: center;">R2<sub>0</sub></td> </tr> <tr> <td style="text-align: center;">1</td> <td style="text-align: center;">TOC</td> </tr> </tbody> </table>	PMR30	R2 <sub>0</sub> /TOC pin mode selection	0	R2 <sub>0</sub>	1	TOC						
PMR30	R2 <sub>0</sub> /TOC pin mode selection																
0	R2 <sub>0</sub>																
1	TOC																
					<table border="1" style="margin-left: auto; margin-right: auto;"> <thead> <tr> <th style="text-align: left;">PMR31</th> <th style="text-align: left;">R2<sub>1</sub>/SCK pin mode selection</th> </tr> </thead> <tbody> <tr> <td style="text-align: center;">0</td> <td style="text-align: center;">R2<sub>1</sub></td> </tr> <tr> <td style="text-align: center;">1</td> <td style="text-align: center;">SCK</td> </tr> </tbody> </table>	PMR31	R2 <sub>1</sub> /SCK pin mode selection	0	R2 <sub>1</sub>	1	SCK						
PMR31	R2 <sub>1</sub> /SCK pin mode selection																
0	R2 <sub>1</sub>																
1	SCK																
					<table border="1" style="margin-left: auto; margin-right: auto;"> <thead> <tr> <th style="text-align: left;">PMR33</th> <th style="text-align: left;">PMR32</th> <th style="text-align: left;">R2<sub>2</sub>/SI/SO pin mode selection</th> </tr> </thead> <tbody> <tr> <td style="text-align: center;">0</td> <td style="text-align: center;">*</td> <td style="text-align: center;">R2<sub>2</sub></td> </tr> <tr> <td style="text-align: center;">1</td> <td style="text-align: center;">0</td> <td style="text-align: center;">SI</td> </tr> <tr> <td></td> <td style="text-align: center;">1</td> <td style="text-align: center;">SO</td> </tr> </tbody> </table>	PMR33	PMR32	R2 <sub>2</sub> /SI/SO pin mode selection	0	*	R2 <sub>2</sub>	1	0	SI		1	SO
PMR33	PMR32	R2 <sub>2</sub> /SI/SO pin mode selection															
0	*	R2 <sub>2</sub>															
1	0	SI															
	1	SO															

\*: Don't care

**Figure 54 Port Mode Register 3 (PMR3)**

- Module standby register 1 (MSR1: \$00D):

Module standby register 1 (MSR1) is a write-only register used to designate supply or stopping of the clock to timer C as shown in figure 46.

Module standby register 1 (MSR1) is reset to \$0 by an MCU reset.

### Timer D (HD404889/HD404899/HD404878 Series)

**Timer D functions :** Timer D has the following functions.

- Free-running/reload timer
- External event counter
- Input capture timer

Block diagrams of timer D in different operating modes are shown in figures 55-1 and 55-2.

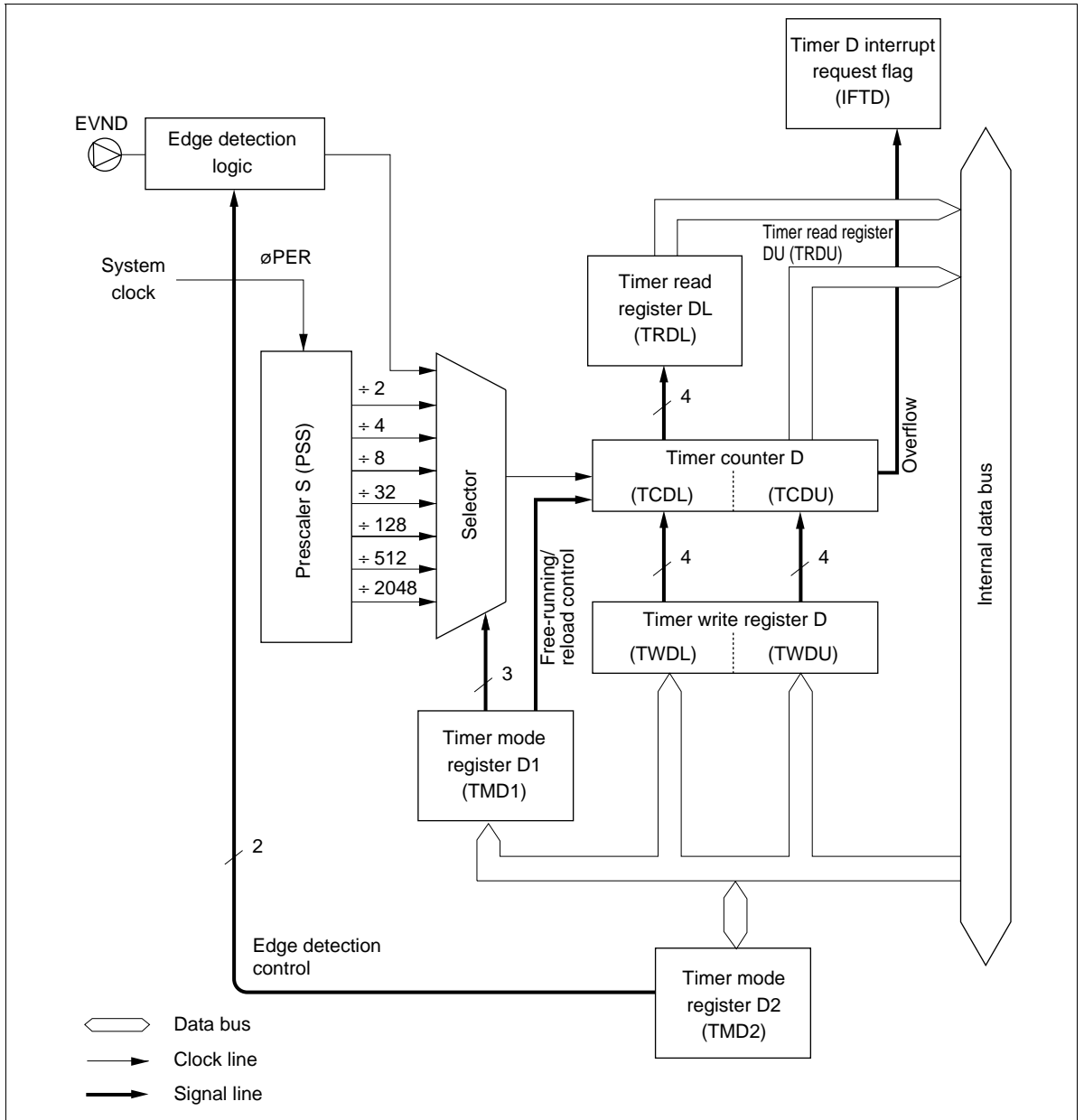


Figure 55-1 Timer D Block Diagram (Reload Timer and Event Counter Modes)

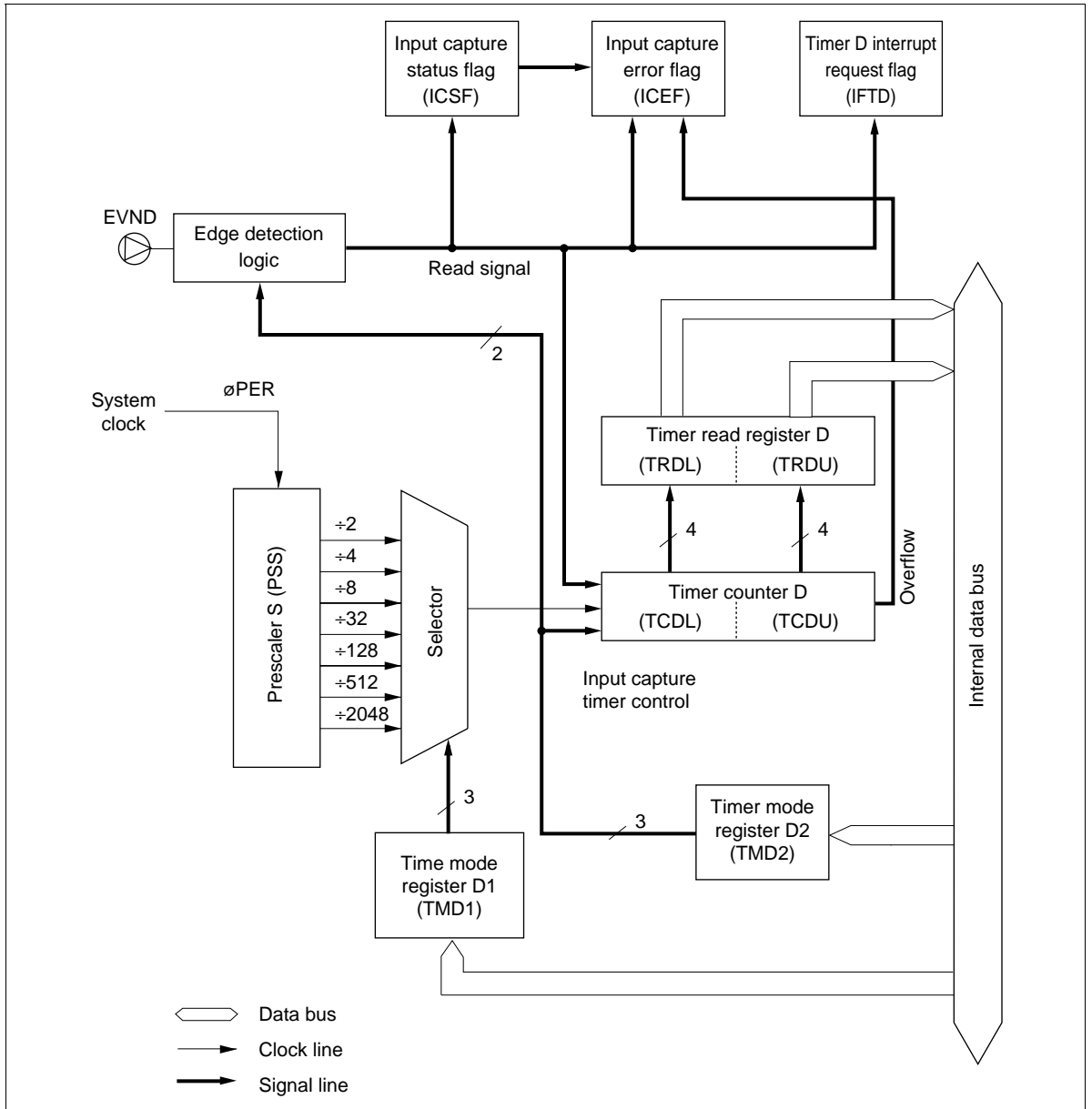


Figure 55-2 Timer D Block Diagram (Input Capture Timer Mode)

## Timer D Operation

- Free-running/reload timer:

Free-running/reload timer operation, the input clock source, and the prescaler division ratio are selected by means of timer mode register D1 (TMD1).

Timer D is initialized to the value written to timer write register D (TWDL, TWDU) by software, and counts up by 1 each time the input clock is input. When the input clock is input after the timer D value reaches \$FF, overflow output is generated. Timer D is then set to the value in timer write register D (TWDL, TWDU) if the reload timer function is selected, or to \$00 if the free-running timer function is selected, and starts counting up again.

Overflow output sets the timer D interrupt request flag (IFTD). This flag is reset by the program or by an MCU reset. For details, see figure 3, Interrupt Control Bit and Register Flag Area Configuration, and table 1, Initial Values after MCU Reset.
- External event counter operation:

When external event input is designated for the input clock, timer D operates as an external event counter. When external event input is used, the R1<sub>1</sub>/EVND pin is designated as the EVND pin by port mode register 2 (PMR2).

The external event detected edge for timer D can be designated as a falling edge, rising edge, or both falling and rising edges in the input signal by means of timer mode register D2 (TMD2). If both falling and rising edges are selected, the input signal falling and rising edge interval should be at least 2tcyc.

Timer D counts up by 1 each time the edge selected by timer mode register D2 (TMD2) is detected. Other operations are the same as for the free-running/reload timer function.
- Input capture timer operation:

The input capture timer function is used to measure the time between trigger input edges input at the EVND pin.

The trigger input edge can be designated as a falling edge, rising edge, or both falling and rising edges by means of timer mode register D2 (TMD2).

When a trigger input edge is detected at the EVND pin, the current timer D value is stored in timer read register D (TRDL, TRDU), and the timer D interrupt request flag (IFTD) and input capture status flag (ICSF) are set. At the same time, timer D is reset to \$00 and continues counting up.

If the next trigger input edge is input while the input capture status flag (ICSF) is set, or if timer D overflows, the input capture error flag (ICEF) is set.

The input capture status flag (ICSF) and input capture error flag (ICEF) are reset to 0 by an MCU reset or by writing 0 to them.

When timer D is set to operate as an input capture timer, it is reset to \$00.

**Timer D Registers:** Timer D operation setting and timer D value reading/writing is controlled by the following registers.

Timer mode register D1 (TMD1: \$018)

Timer mode register D2 (TMD2: \$019)

Timer write register D (TWDL: \$01A, TWDU: \$01B)

Timer read register D (TRDL: \$01A, TRDU: \$01B)

Port mode register 2 (PMR2: \$00A)

Module standby register 1 (MSR1: \$00D)

- **Timer mode register D1 (TMD1: \$018):**

Timer mode register D1 (TMD1) is a 4-bit write-only register, used to select free-running/reload timer operation, the input clock, and the prescaler division ratio as shown in figure 56.

Timer mode register D1 (TMD1) is reset to \$0 by an MCU reset.

A modification of timer mode register D1 (TMD1) becomes effective after execution of two instructions following the timer mode register D1 (TMD1) write instruction. The program must provide for timer D initialization by writing to timer write register D (TWDL, TWDU) to be executed after the post-modification mode has become effective.

When timer D is set to operate as an input capture timer, an internal clock should be set as the input clock.

Timer mode register D1 (TMD1: \$018)

Bit	3	2	1	0
Read/Write	W	W	W	W
Initial value on reset	0	0	0	0
Bit name	TMD13	TMD12	TMD11	TMD10

	TMD12	TMD11	TMD10	Input clock period and input clock source
0	0	0	0	2,048 $t_{cyc}$
		1	1	512 $t_{cyc}$
	1	0	0	128 $t_{cyc}$
		1	1	32 $t_{cyc}$
1	0	0	0	8 $t_{cyc}$
		1	1	4 $t_{cyc}$
	1	0	0	2 $t_{cyc}$
			1	R11/EVND (external event input)

TMD13	Free-running/reload timer
0	Free-running timer
1	Reload timer

**Figure 56 Timer Mode Register D1 (TMD1)**

- Timer mode register D2 (TMD2: \$019):

Timer mode register D2 (TMD2) is a 3-bit write-only register, used to select the EVND pin detected edge and input capture operation as shown in figure 57.

Timer mode register D2 (TMD2) is reset to \$0 by an MCU reset.

Timer mode register D2 (TMD2: \$019)

Bit	3	2	1	0
Read/Write	—	W	W	W
Initial value on reset	—	0	0	0
Bit name	—	TMD22	TMD21	TMD20

TMD21	TMD20	EVND pin detected edge
0	0	Not detected
	1	Falling edge detection
1	0	Rising edge detection
	1	Both rising and falling edge detection

TMD22	Input capture setting
0	Free-running/reload timer
1	Input capture timer

**Figure 57 Timer Mode Register D2 (TMD2)**

- Timer write register D (TWDL: \$01A, TWDU: \$01B):

Timer write register D (TWDL, TWDU) is a write-only register composed of a lower digit (TWDL) and an upper digit (TWDU) (figures 58 and 59).

Timer write register D (TWDL, TWDU) operation is similar to that for timer write register B (TWBL, TWBU).

Timer write register D (lower) (TWDL: \$01A)

Bit	3	2	1	0
Read/Write	W	W	W	W
Initial value on reset	0	0	0	0
Bit name	TWDL3	TWDL2	TWDL1	TWDL0

**Figure 58 Timer Write Register D (Lower) (TWDL)**

Timer write register D (upper) (TWDU: \$01B)

<b>Bit</b>	<b>3</b>	<b>2</b>	<b>1</b>	<b>0</b>
Read/Write	W	W	W	W
Initial value on reset	Undetermined	Undetermined	Undetermined	Undetermined
Bit name	TWDU3	TWDU2	TWDU1	TWDU0

**Figure 59 Timer Write Register D (Upper) (TWDU)**

- Timer read register D (TRDL: \$01A, TRDU: \$01B):

Timer read register D (TRDL, TRDU) is a read-only register composed of a lower digit (TRDL) and an upper digit (TRDU) (figures 60 and 61).

Timer read register D (TRDL, TRDU) operation is similar to that for timer read register B (TRBL, TRBU).

In the input capture timer operating mode, when the timer D value is read after trigger input, it does not matter whether the lower or upper digit is read first.

Timer read register D (lower) (TRDL: \$01A)

<b>Bit</b>	<b>3</b>	<b>2</b>	<b>1</b>	<b>0</b>
Read/Write	R	R	R	R
Initial value on reset	Undetermined	Undetermined	Undetermined	Undetermined
Bit name	TRDL3	TRDL2	TRDL1	TRDL0

**Figure 60 Timer Read Register D (Lower) (TRDL)**

Timer read register D (upper) (TRDU: \$01B)

<b>Bit</b>	<b>3</b>	<b>2</b>	<b>1</b>	<b>0</b>
Read/Write	R	R	R	R
Initial value on reset	Undetermined	Undetermined	Undetermined	Undetermined
Bit name	TRDU3	TRDU2	TRDU1	TRDU0

**Figure 61 Timer Read Register D (Upper) (TRDU)**

- Port mode register 2 (PMR2: \$00A):  
Port mode register 2 (PMR2) is a write-only register used to set the R1<sub>1</sub>/EVND pin function as shown in figure 45.  
Port mode register 2 (PMR2) is reset to \$0 by an MCU reset.
- Module standby register 1 (MSR1: \$00D):  
Module standby register 1 (MSR1) is a write-only register used to designate supply or stopping of the clock to timer D as shown in figure 46.  
Module standby register 1 (MSR1) is reset to \$0 by an MCU reset.

## Serial Interface

The serial interface serially transfers and receives 8-bit data, and includes the following features.

- Multiple transmit clock sources
  - External clock
  - Internal prescaler output clock
  - System clock
- Output level control in idle states

Five registers, an octal counter, and a multiplexer are also configured for the serial interface as follows.

- Serial data register (SRL: \$026, SRU: \$027)
- Serial mode register 1 (SMR1: \$024)
- Serial mode register 2 (SMR2: \$025)
- Port mode register 3 (PMR3: \$00B)
- Octal counter (OC)
- Selector

The block diagram of the serial interface is shown in figure 62.

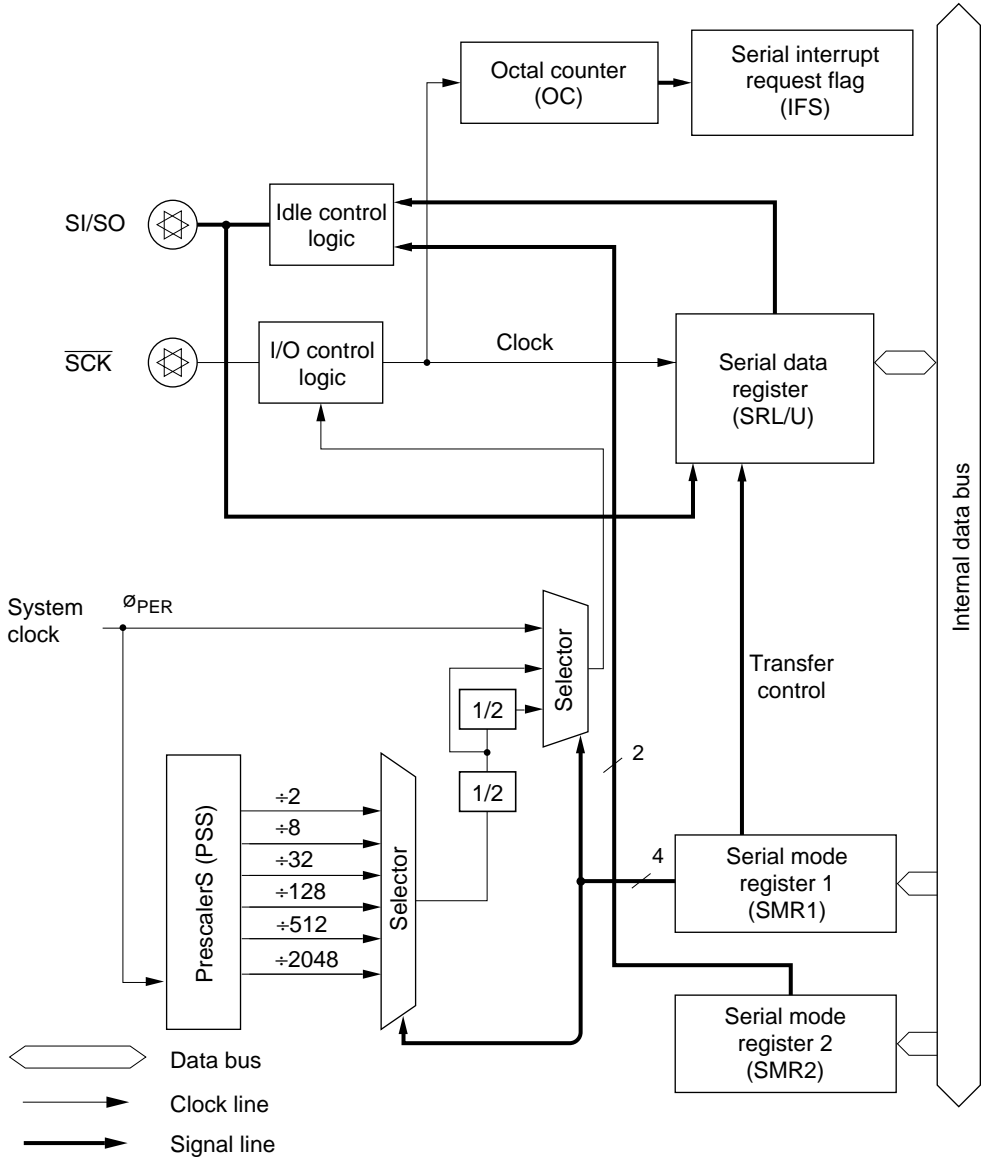


Figure 62 Serial Interface Block Diagram

## Serial Interface Operation

### Selecting and changing serial interface operating mode:

The operating modes that can be selected for the serial interface are shown in table 26. The combination of port mode register 3 (PMR3) values should be selected from this table. When the serial interface operating mode is changed, the serial interface internal state must be initialized by writing to serial mode register 1 (SMR1).

Note : The serial interface is initialized by writing to serial mode register 1 (SMR1: \$024). See serial mode register 1 for details.

**Table 26 Serial Interface Operating Modes**

Bit3	PMR3		Serial interface operating mode
	Bit2	Bit1	
0	*	1	Clock continuous output mode
1	0	1	Receive mode
1	1	1	Transmit mode

\*: Don't care

### Serial interface pin setting:

The  $R2_1/\overline{SCK}$  pin and  $R2_2/SI/SO$  pin are set by writing data to port mode register 3 (PMR3). See serial interface registers for details.

### Serial clock source setting:

The serial clock is set by writing data to serial mode register 1 (SMR1). See serial interface registers for details.

### Serial data setting:

Transmit serial data is set by writing data to the serial data register (SRL, SRU).

Receive serial data is obtained by reading the serial data register (SRL, SRU). Serial data is shifted by means of the serial clock to perform input/output from/to an external device.

The output level of the SO pin is undetermined until the first data is output after a reset by the MCU, or until high/low control is performed in the idle state.

### Transfer control:

Serial interface operation is started by an STS instruction. The octal counter is reset to 000 by the STS instruction, and is incremented by 1 on each rise of the serial clock. When 8 serial clock pulses have been input, or if data transmission/reception is suspended midway, the octal counter is reset to 000, the serial interrupt request flag (IFS) is set, and transfer is terminated.

The serial clock is selected by means of serial mode register 1 (SMR1). See figure 66.

**Serial interface operating states:**

The serial interface has the operating states shown in figure 63 in external clock mode and internal clock mode.

STS instruction wait state  
Serial clock wait state  
Transfer state  
Clock continuous output state (internal clock mode only)

- STS instruction wait state

Upon MCU reset ((00) and (10) in figure 63), the serial interface enters the STS instruction wait state. In the STS instruction wait state, the internal state of the serial interface is initialized. Even if the serial clock is input at this time, the serial interface will not operate. When the STS instruction is executed ((01), (11)), the serial interface enters the serial clock wait state.

- Serial clock wait state

The serial clock wait state is the interval from STS instruction execution until the first serial clock falling edge. When the serial clock is input in the serial clock wait state ((02), (12)), the octal counter begins counting, the contents of the serial data register (SRL) begin shifting, and the serial interface enters the transfer state. However, if clock continuous output mode is selected in internal clock mode, the serial interface enters the clock continuous output state ((17)) instead of the transfer state.

If a write to serial mode register 1 (SMR1) is performed in the serial clock wait state, the serial interface enters the STS instruction wait state ((04), (14)).

- Transfer state

The transfer state is the interval from the first serial clock falling edge until the eighth serial clock rising edge. In the transfer state, if an STS instruction is executed or if eight serial clocks have been input, the octal counter is cleared to 000, and the serial interface makes a state transition. If an STS instruction is executed ((05), (15)), the serial interface enters the serial clock wait state. After eight serial clocks have been input, the serial interface enters the serial clock wait state ((03)) when in external clock mode, and enters the STS instruction wait state ((13)) when in internal clock mode.

In internal clock mode, the serial clock stops after output of eight clocks.

If a write to serial mode register 1 (SMR1) is performed in the transfer state ((06), (16)), the serial interface is initialized and enters the STS instruction wait state.

When the serial interface switches from the transfer state to another state, the octal counter is reset to 000 and the serial interrupt request flag (IFS) is set.

- Clock continuous output state (internal clock mode only)

In the clock continuous output state, no receive or transmit operation is performed, and the serial clock is only output from the  $\overline{SCK}$  pin. It is therefore effective in internal clock mode.

If the serial clock is input ((17)) when bit 3 (PMR33) of port mode register 3 (PMR3) is cleared to 0 and the serial interface is in the serial clock wait state, a transition is made to the clock continuous output state.

If a write to serial mode register 1 (SMR1) is performed in the clock continuous output state ((18)), the serial interface enters the STS instruction wait state.

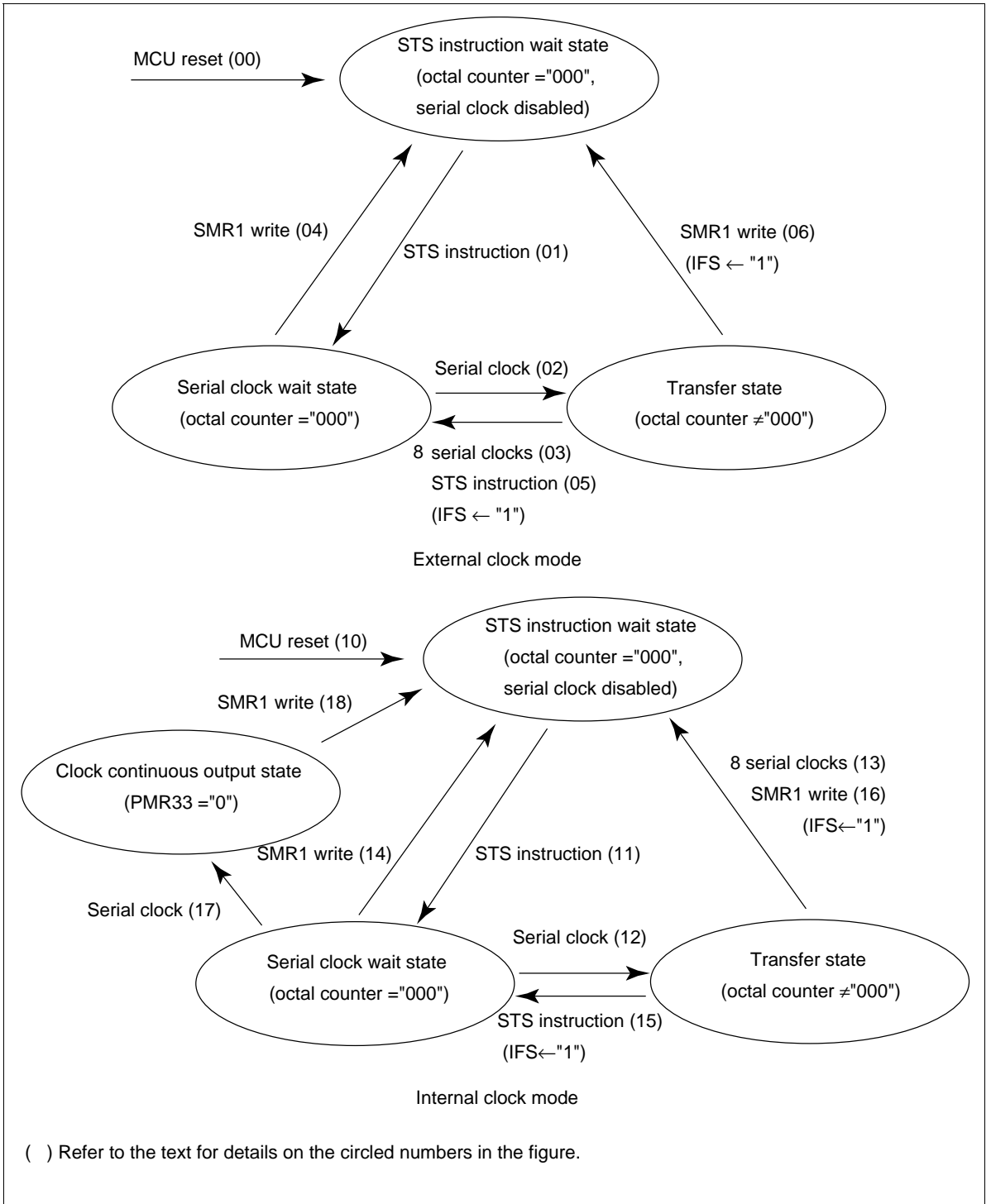
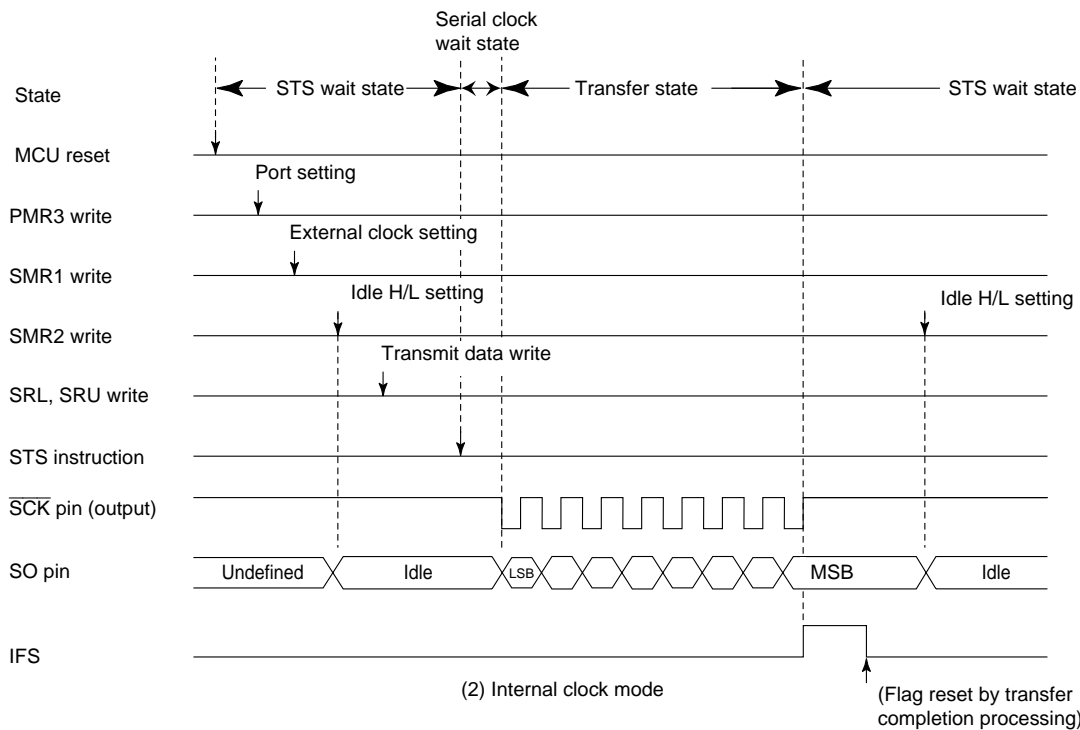
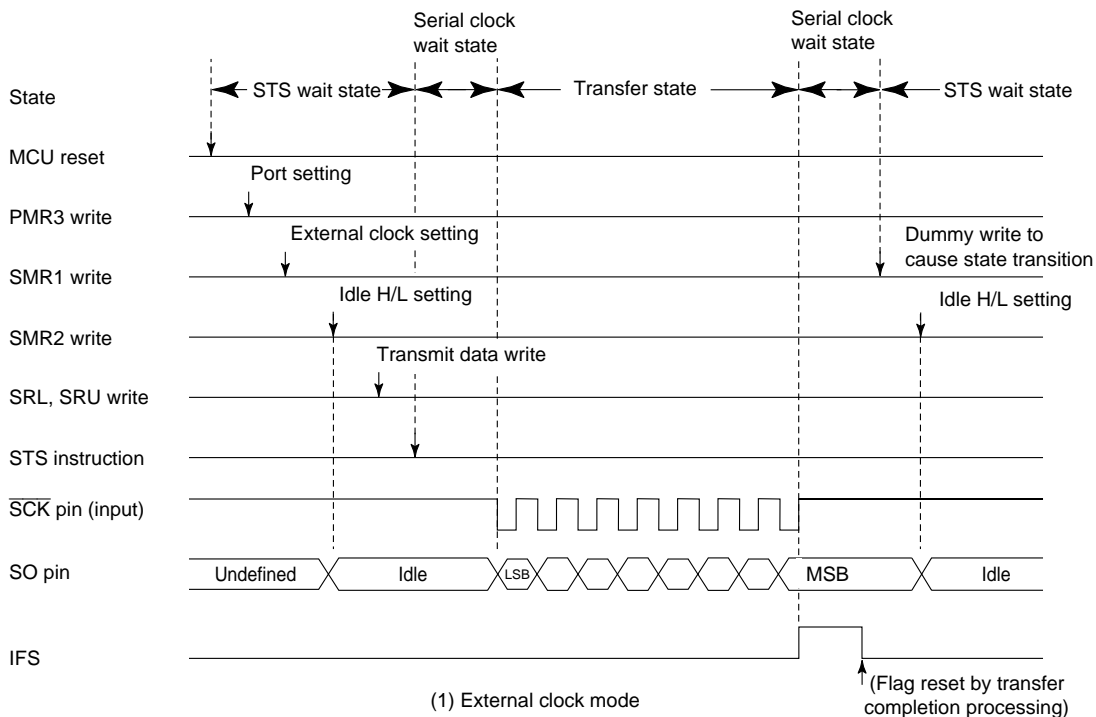


Figure 63 Serial Interface Operating States

### **Idle high/low control:**

When the serial interface is in the STS instruction wait state or the serial clock wait state (i.e. when idle), the output level of the SO pin can be set arbitrarily by software. Idle high/low control is performed by writing the output level to bit 1 (SMR21) of serial mode register 2 (SMR2).

An example of idle high/low control is shown in figure 64. Idle high/low control cannot be performed in the transfer state.



**Figure 64** Examples of Serial Interface Operation Sequence

**Serial clock error detection (external clock mode):**

The serial interface will operate incorrectly in the transfer state if external noise results in unnecessary pulses being added to the serial clock. Serial clock error detection in such cases is carried out as shown in figure 65.

If more than eight serial clock pulses are input due to external noise while in the transfer state, at the eighth clock pulse (including any external noise pulses), the octal counter is cleared to 000 and the serial interrupt request flag (IFS) is set. At the same time, the serial interface exits the transfer state and enters the serial clock wait state, but returns to the transfer state at the next regular clock pulse falling edge.

Meanwhile, in the interrupt handling routine, transfer end processing is performed, the serial interrupt request flag is reset, and a dummy write is performed into serial mode register 1 (SMR1). The serial interface then returns to the STS wait state, and the serial interrupt request flag (IFS) is set again. It is therefore possible to detect a serial clock error by testing the serial interrupt request flag after the dummy write to serial mode register 1.

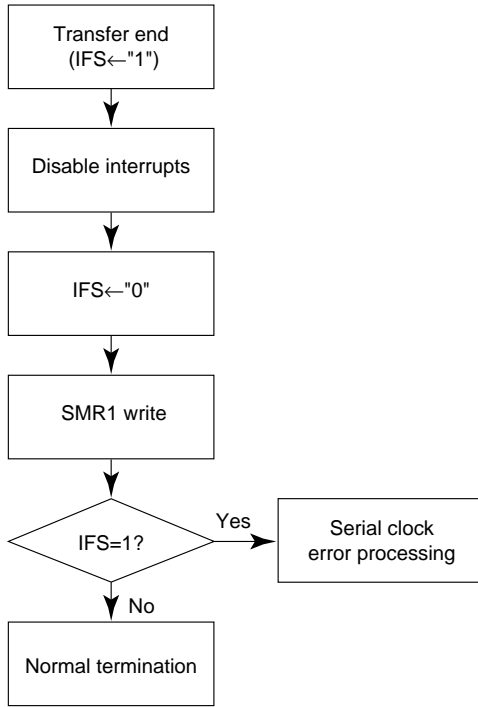
**Usage notes:**

- Initialization after register modification

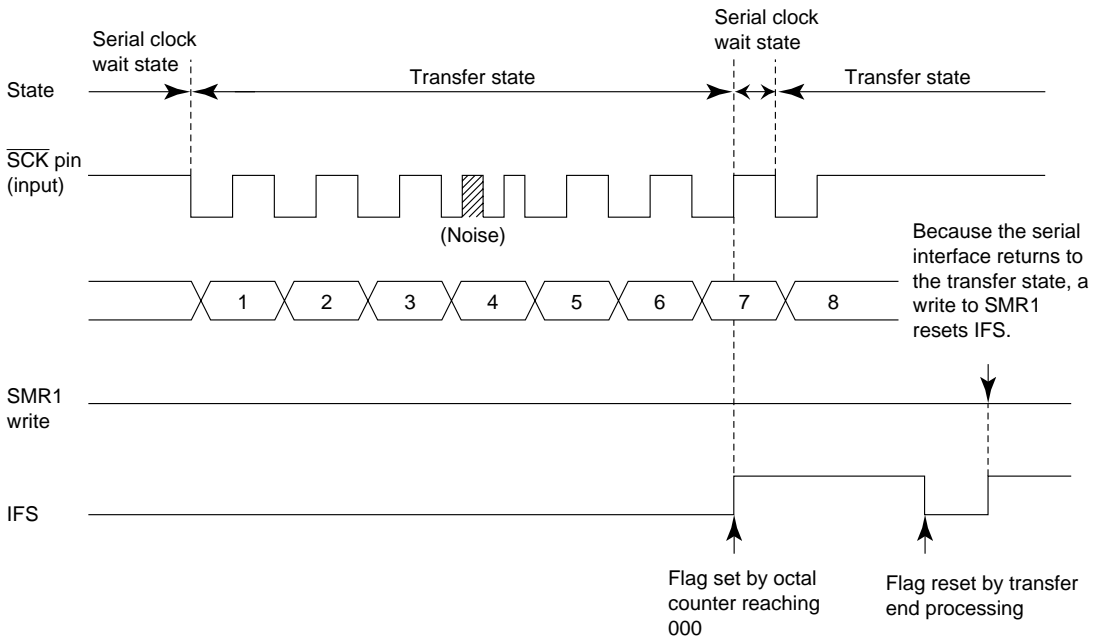
If a port mode register 3 (PMR3) write is performed in the serial clock wait state or transfer state, a serial mode register 1 (SMR1) write should be performed again to initialize the serial interface.

- Serial interrupt request flag (IFS:\$023, 2) setting

If a serial mode register 1 (SMR1) write or STS instruction is executed during the first low-level interval of the serial clock in the transfer state, the serial interrupt request flag (IFS) will not be set. To ensure that the serial interrupt request flag (IFS) is properly set in this case, programming is required to make sure that the  $\overline{SCK}$  pin is in the 1 state (by executing an input instruction for the R2 port) before executing a serial mode register 1 (SMR1) write or an STS instruction.



(1) Serial clock error detection flowchart



(2) Serial clock error detection sequence

Figure 65 Example of Serial Clock Error Detection

## Serial Interface Registers

Serial interface operation setting and serial data reading/writing is controlled by the following registers.

Serial mode register 1 (SMR1: \$024)

Serial mode register 2 (SMR2: \$025)

Serial data register (SRL: \$026, SRU: \$027)

Port mode register 3 (PMR3: \$00B)

Module standby register 2 (MSR2: \$00E)

### **Serial mode register 1 (SMR1: \$024):**

Serial mode register 1 (SMR1) has the following functions. See figure 66.

- Serial clock selection
- Prescaler division ratio selection
- Serial interface initialization

The serial mode register 1 (SMR1) is a 4-bit write-only register, and is reset to \$0 by an MCU reset.

A write to serial mode register 1 (SMR1) halts the supply of the serial clock to the serial data register (SRL, SRU) and the octal counter, and resets the octal counter to 000. Therefore, if serial mode register 1 (SMR1) is written to during serial interface operation, data transmission/reception will be suspended and the serial interrupt request flag (IFS) will be set.

A modification of serial mode register 1 (SMR1) becomes effective after execution of two instructions following the serial mode register 1 (SMR1) write instruction. The program must therefore provide for the STS instruction to be executed two cycles after the instruction that writes to serial mode register 1 (SMR1).

Serial mode register 1 (SMR1: \$024)

Bit	3	2	1	0
Read/Write	W	W	W	W
Initial value on reset	0	0	0	0
Bit name	SMR13	SMR12	SMR11	SMR10

SMR13	SMR12	SMR11	SMR10	$\overline{\text{SCK}}$ pin	Serial clock source	Serial clock (PSS division ratio $\div 2$ or 4)	Serial clock cycle
0	0	0	0	Output	PSS	$(\phi_{\text{PER}}/2048)\div 2$	4096 tcyc
		1	1	Output	PSS	$(\phi_{\text{PER}}/512)\div 2$	1024 tcyc
		0	0	Output	PSS	$(\phi_{\text{PER}}/128)\div 2$	256 tcyc
		1	1	Output	PSS	$(\phi_{\text{PER}}/32)\div 2$	64 tcyc
	1	0	0	Output	PSS	$(\phi_{\text{PER}}/8)\div 2$	16 tcyc
		0	1	Output	PSS	$(\phi_{\text{PER}}/2)\div 2$	4 tcyc
		1	0	Output	System clock	$\phi_{\text{PER}}$	tcyc
		1	1	Input	External clock	—	—
1	0	0	0	Output	PSS	$(\phi_{\text{PER}}/2048)\div 4$	8192 tcyc
		1	1	Output	PSS	$(\phi_{\text{PER}}/512)\div 4$	2048 tcyc
		0	0	Output	PSS	$(\phi_{\text{PER}}/128)\div 4$	512 tcyc
		1	1	Output	PSS	$(\phi_{\text{PER}}/32)\div 4$	128 tcyc
	1	0	0	Output	PSS	$(\phi_{\text{PER}}/8)\div 4$	32 tcyc
		0	1	Output	PSS	$(\phi_{\text{PER}}/2)\div 4$	8 tcyc
		1	0	Output	System clock	$\phi_{\text{PER}}$	tcyc
		1	1	Input	External clock	—	—

**Figure 66 Serial Mode Register 1 (SMR1)**

### Serial mode register 2 (SMR2: \$025):

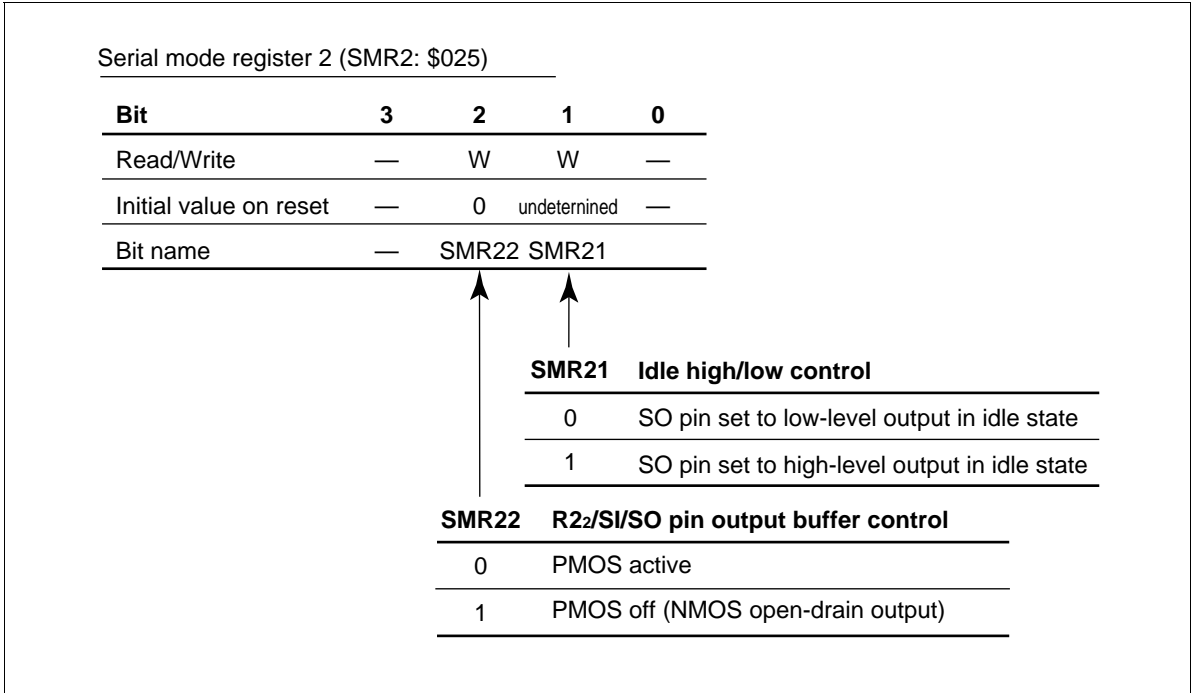
Serial mode register 2 (SMR2) has the following functions. See figure 67.

- R<sub>2</sub>/SI/SO pin PMOS control
- Idle high/low control

Serial mode register 2 (SMR2) is a 2-bit write-only register. The register value cannot be modified in the transfer state.

Bit 2 (SMR22) of serial mode register 2 (SMR2) controls the on/off status of the R<sub>2</sub>/SI/SO pin PMOS. The bit 2 (SMR22) only is reset to 0 by an MCU reset.

Bit 1 (SMR21) of serial mode register 2 (SMR2) performs SO pin high/low control in the idle state. The SO pin changes at the same time as the high/low write.



**Figure 67 Serial Mode Register 2 (SMR2)**

### Serial data register (SRL: \$026, SRU: \$027):

The serial data register (SRL, SRU) has the following functions. See figures 68 and 69.

- Transmit data write and shift operations
- Receive data shift and read operations

The data written to the serial data register (SRL, SRU) is output LSB-first from the SO pin in synchronization with the falling edge of the serial clock.

External data input LSB-first from the SI pin is latched in synchronization with the rising edge of the serial clock. Figure 70 shows the serial clock and data input/output timing chart.

Writing and reading of the serial data register (SRL, SRU) must be performed only after data transmission/reception is completed. The data contents are not guaranteed if a read or write is performed during data transmission or reception.

Serial data register (lower) (SRL: \$026)

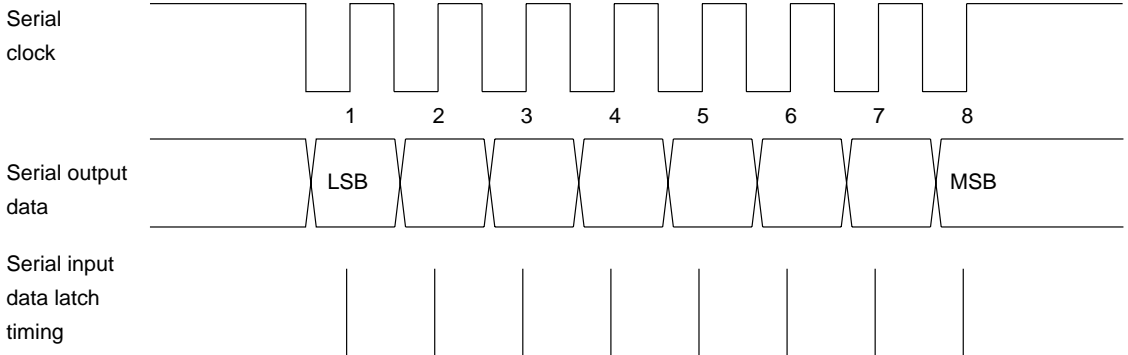
Bit	3	2	1	0
Read/Write	R/W	R/W	R/W	R/W
Initial value on reset	Undetermined	Undetermined	Undetermined	Undetermined
Bit name	SR3	SR2	SR1	SR0

**Figure 68 Serial Data Register (SRL)**

Serial data register (upper) (SRU: \$027)

Bit	3	2	1	0
Read/Write	R/W	R/W	R/W	R/W
Initial value on reset	Undetermined	Undetermined	Undetermined	Undetermined
Bit name	SR7	SR6	SR5	SR4

**Figure 69 Serial Data Register (SRU)**



**Figure 70 Serial Interface Input/Output Timing Chart**

## Port mode register 3 (PMR3: \$00B):

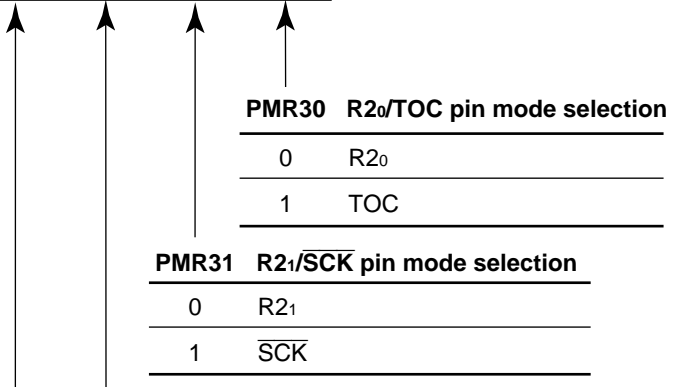
Port mode register 3 (PMR3) has the following functions. See figure 71.

- R<sub>2</sub> $\overline{\text{SCK}}$  pin selection
- R<sub>2</sub>/SI/SO pin selection

Port mode register 3 (PMR3) is a 4-bit write-only register used to select serial interface pin settings as shown in figure 71. It is reset to \$0 by an MCU reset.

Port mode register 3 (PMR3: \$00B)

Bit	3	2	1	0
Read/Write	W	W	W	W
Initial value on reset	0	0	0	0
Bit name	PMR33	PMR32	PMR31	PMR30



PMR33	PMR32	R <sub>2</sub> /SI/SO pin mode selection
0	*	R <sub>2</sub> <sub>2</sub>
1	0	SI
	1	SO

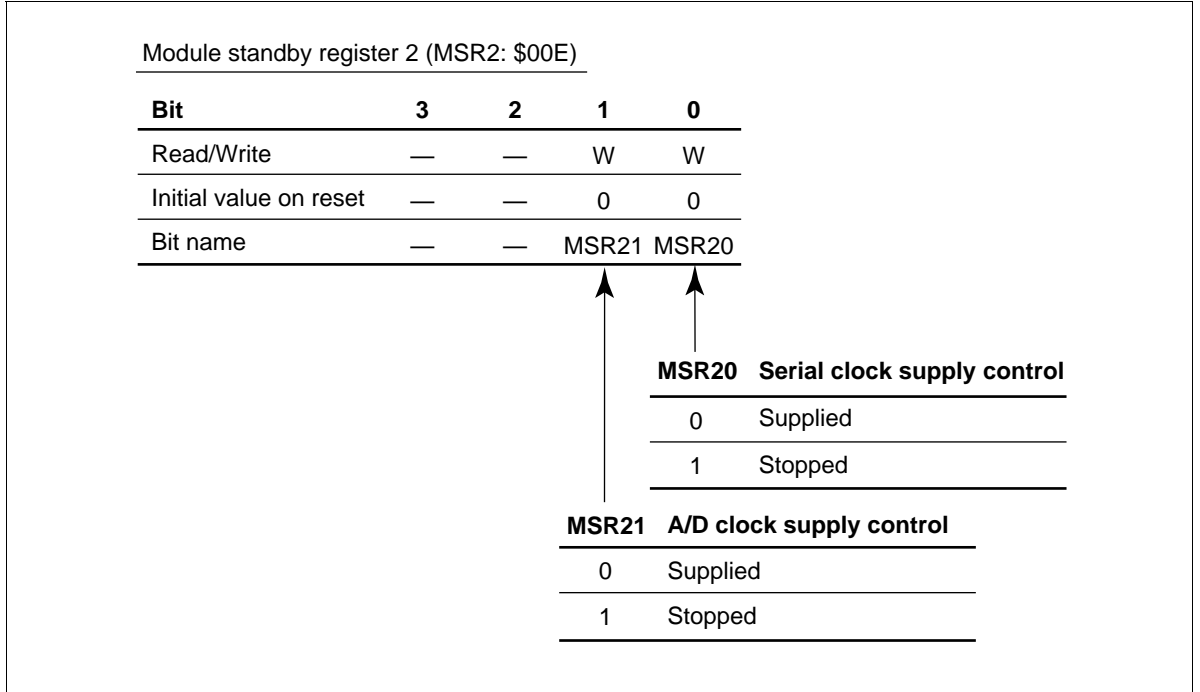
\* : Don't care

Figure 71 Port Mode Register 3 (PMR3)

**Module standby register 2 (MSR2: \$00E):**

Module standby register 2 (MSR2) is a write-only register used to designate supply or stopping of the clock to the serial interface as shown in figure 72.

Module standby register 2 (MSR2) is reset to \$0 by an MCU reset.



**Figure 72 Module Standby Register 2 (MSR2)**



### A/D mode register (AMR: \$028):

The A/D mode register is a 4-bit write-only register that shows the A/D converter speed setting and information on the analog input pin specification. The A/D conversion time is selected by bit 0, and the channel by bits 1, 2, and 3 (figure 74).

### A/D start flag (ADSF: \$020,2):

A/D conversion is started by writing 1 to the A/D start flag. When conversion ends, the converted data is placed in the A/D data register and the A/D start flag is cleared at the same time. (figure 75).

A/D mode register (AMR: \$028)

Bit	3	2	1	0
Read/Write	W	W	W	W
Initial value on reset	0	0	0	0
Bit name	AMR3	AMR2	AMR1	AMR0

AMR0	A/D conversion time
0	65 t <sub>cyc</sub>
1	125 t <sub>cyc</sub>

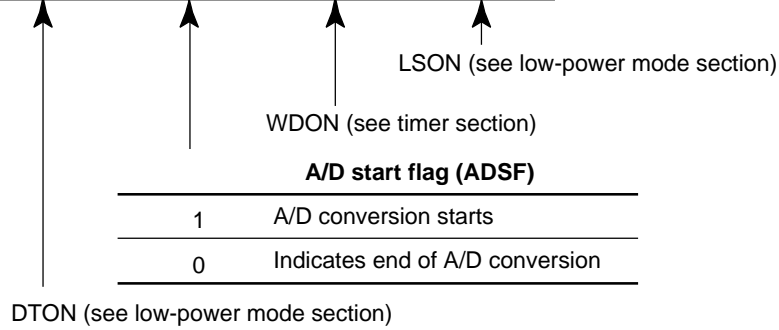
AMR3	AMR2	AMR1	Analog input channel selection
0	0	*	No selection
	1	0	AN0
		1	AN1
	0	0	AN2
		1	AN3
1	0	0	AN4
	1	1	AN5

\* : Don't care

**Figure 74 A/D Mode Register (AMR)**

A/D start flag (ADSF: \$020,2)

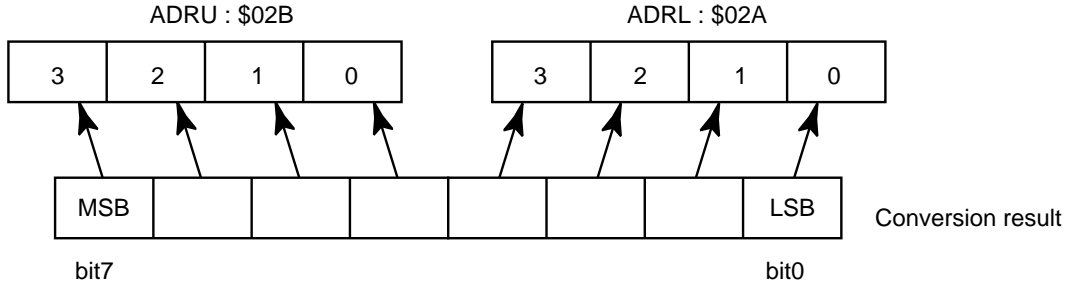
Bit	3	2	1	0
Read/Write	R/W	R/W	R/W	R/W
Initial value on reset	0	0	0	0
Bit name	DTON	ADSF	WDON	LSON



**Figure 75 A/D Start Flag (ADSF)**

**A/D data register (ADRL: \$02A, ADRU: \$02B):**

The A/D data register is a read-only register consisting of a lower and upper 4 bits. This register is not cleared by a reset. Also, data read during A/D conversion is not guaranteed. At the end of A/D conversion, the resulting 8-bit data is stored in this register, and is held until the next conversion operation starts (figures 76, 77, and 78).



**Figure 76 A/D Data Register**

A/D data register-lower (ADRL: \$02A)

<b>Bit</b>	<b>3</b>	<b>2</b>	<b>1</b>	<b>0</b>
Read/Write	R	R	R	R
Initial value on reset	1	1	1	1
Bit name	ADRL3	ADRL2	ADRL1	ADRL0

**Figure 77 A/D Data Register-Lower (ADRL)**

A/D data register-upper (ADRU: \$02B)

<b>Bit</b>	<b>3</b>	<b>2</b>	<b>1</b>	<b>0</b>
Read/Write	R	R	R	R
Initial value on reset	0	1	1	1
Bit name	ADRU3	ADRU2	ADRU1	ADRU0

**Figure 78 A/D Data Register-Upper (ADRU)**

**Module standby register 2 (MSR2: \$00E):**

Writing 1 to bit 1 of module standby register 2 stops the supply of the system clock to the A/D module and cuts the current ( $I_{AD}$ ) flowing in the ladder resistor.

**Usage notes:**

- Use the SEM or SEMD instruction to write to the A/D start flag (ADSF).
- Do not write to the ADSF during A/D conversion.
- Data in the A/D data register is undetermined during A/D conversion.
- As the A/D converter operates on a clock from OSC, it stops in stop mode, watch mode, and subactive mode. The current flowing in the A/D converter ladder resistor is also cut in these low-power modes to reduce power consumption.
- When an analog input pin is selected by the A/D mode register, the pull-up MOS for that pin is disabled.

## A/D Converter

### HD404899/HD404868 Series

The MCU has a built-in successive approximation type A/D converter using a resistance ladder method, capable of digital conversion of six analog inputs (four analog inputs in the HD404868 Series) with a 10-bit resolution. The A/D converter block diagram is shown in figures 79-1 and 79-2.

The A/D converter comprises the following four registers.

- A/D mode register (AMR: \$028)
- A/D start flag (ADSF: \$020,2)
- A/D data register (ADRL: \$029, ADRM: \$02A, ADRU: \$02B)
- Module standby register 2 (MSR2: \$00E)

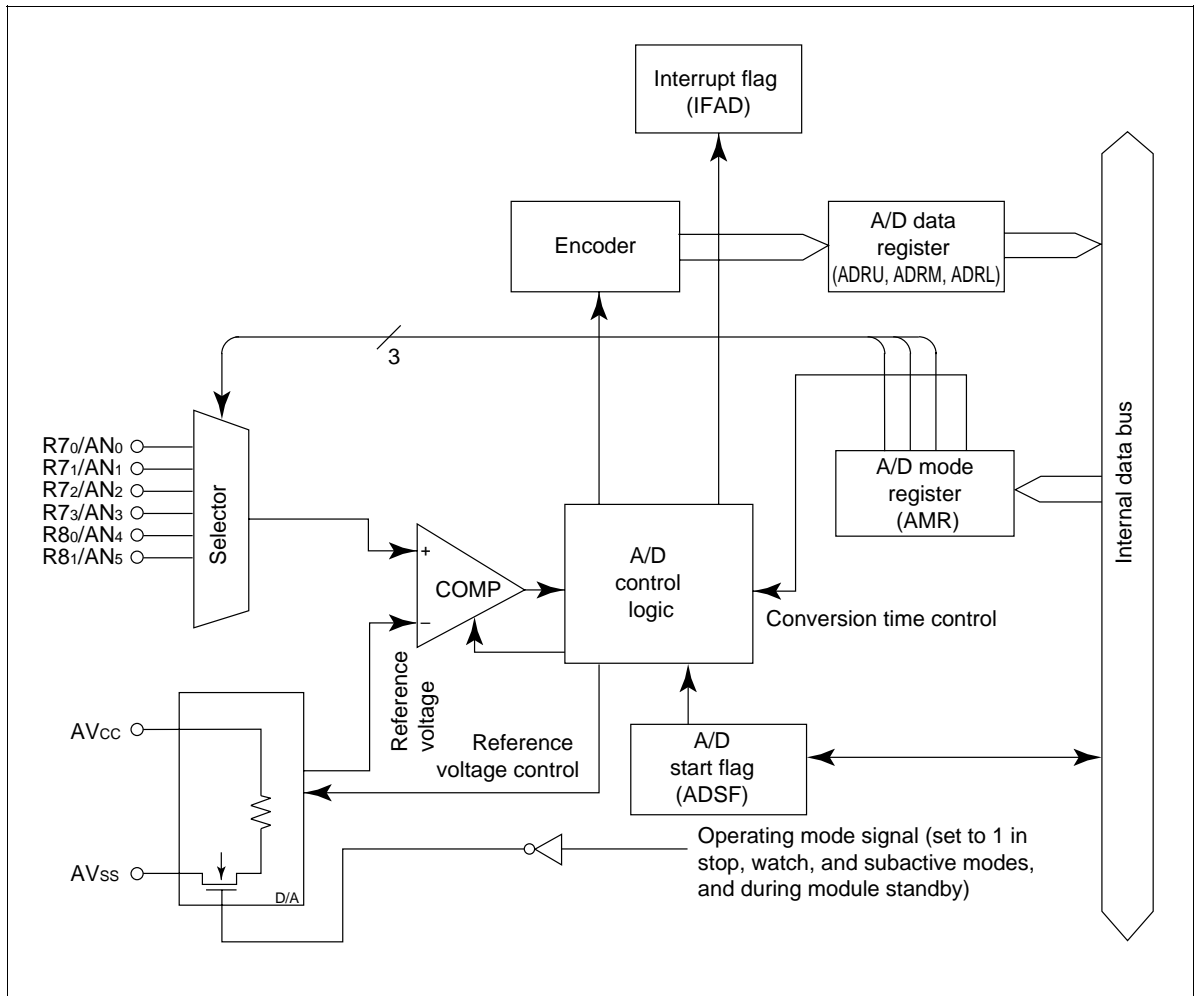


Figure 79-1 A/D Converter Block Diagram (HD404899 Series)

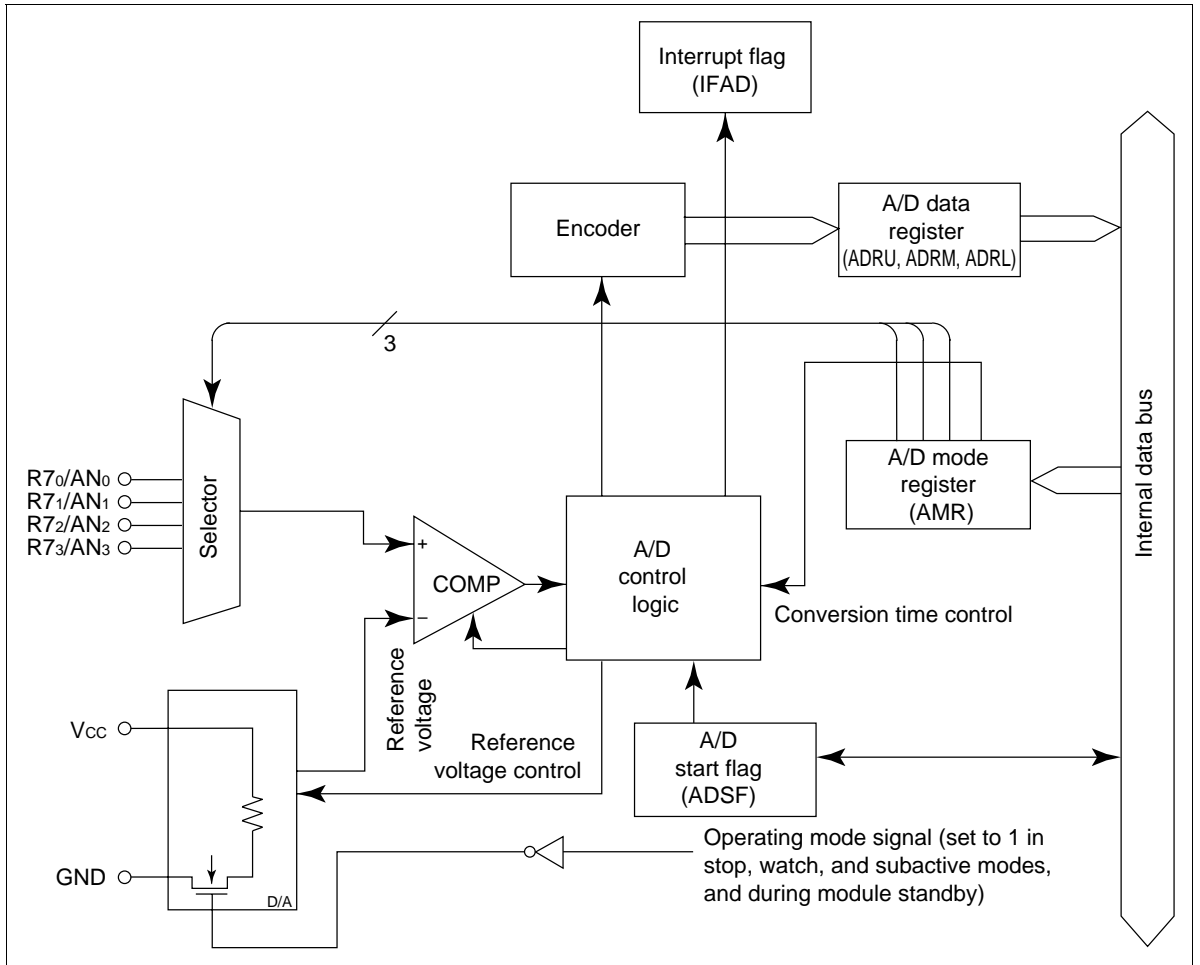


Figure 79-2 A/D Converter Block Diagram (HD404868 Series)

# HD404889/HD404899/HD404878/HD404868 Series

## A/D mode register (AMR: \$028):

The A/D mode register is a 4-bit write-only register that shows the A/D converter speed setting and information on the analog input pin specification. The A/D conversion time is selected by bit 0, and the channel by bits 1, 2, and 3 (figure 80).

## A/D start flag (ADSF: \$020,2):

A/D conversion is started by writing 1 to the A/D start flag. When conversion ends, the converted data is placed in the A/D data register and the A/D start flag is cleared at the same time. (figure 81).

A/D mode register (AMR: \$028)

Bit	3	2	1	0
Read/Write	W	W	W	W
Initial value on reset	0	0	0	0
Bit name	AMR3	AMR2	AMR1	AMR0

AMR0	A/D conversion time
0	65 t <sub>cyc</sub>
1	125 t <sub>cyc</sub>

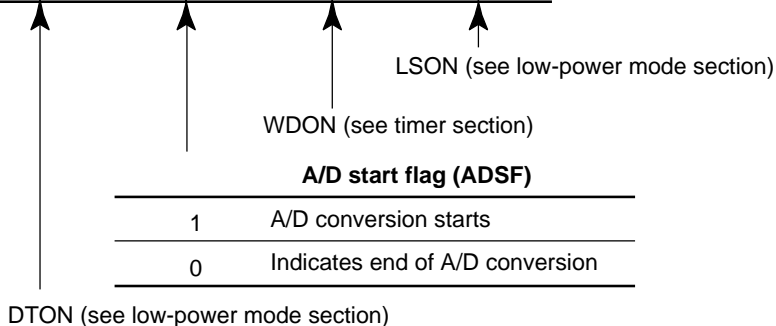
AMR3	AMR2	AMR1	Analog input channel selection	
0	0	*	No selection	
	1	0	AN0	
		1	AN1	
1	0	0	AN2	
		1	AN3	
	1	0	AN4*	
		1	0	AN4*
			1	AN5*

Note: \* Applies to HD404899 Series.

Figure 80 A/D Mode Register (AMR)

A/D start flag (ADSF: \$020,2)

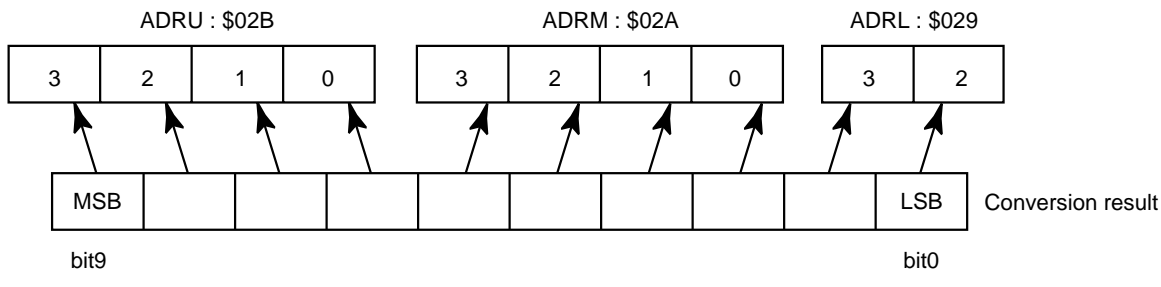
Bit	3	2	1	0
Read/Write	R/W	R/W	R/W	R/W
Initial value on reset	0	0	0	0
Bit name	DTON	ADSF	WDON	LSON



**Figure 81 A/D Start Flag (ADSF)**

**A/D data register (ADRL: \$029, ADRM: \$02A, ADRU: \$02B):**

The A/D data register is a read-only register consisting of a middle and upper 4 bits. This register is not cleared by a reset. Also, data read during A/D conversion is not guaranteed. At the end of A/D conversion, the resulting 10-bit data is stored in this register, and is held until the next conversion operation starts (figures 82, 83, 84 and 85).



**Figure 82 A/D Data Register**

A/D data register-lower (ADRL: \$029)

Bit	3	2	1	0
Read/Write	R	R	—	—
Initial value on reset	1	1	—	—
Bit name	ADRL3	ADRL2	Not used	Not used

**Figure 83 A/D Data Register-Lower (ADRL)**

A/D data register-middle (ADRM: \$02A)

Bit	3	2	1	0
Read/Write	R	R	R	R
Initial value on reset	1	1	1	1
Bit name	ADRM3	ADRM2	ADRM1	ADRM0

**Figure 84 A/D Data Register-Middle (ADRM)**

A/D data register-upper (ADRU: \$02B)

Bit	3	2	1	0
Read/Write	R	R	R	R
Initial value on reset	0	1	1	1
Bit name	ADRU3	ADRU2	ADRU1	ADRU0

**Figure 85 A/D Data Register-Upper (ADRU)**

**Module standby register 2 (MSR2: \$00E):**

Writing 1 to bit 1 of module standby register 2 stops the supply of the system clock to the A/D module and cuts the current ( $I_{AD}$ ) flowing in the ladder resistor.

**Usage notes:**

- Use the SEM or SEMD instruction to write to the A/D start flag (ADSF).
- Do not write to the ADSF during A/D conversion.
- Data in the A/D data register is undetermined during A/D conversion.

- As the A/D converter operates on a clock from OSC, it stops in stop mode, watch mode, and subactive mode. The current flowing in the A/D converter ladder resistor is also cut in these low-power modes to reduce power consumption.
- When an analog input pin is selected by the A/D mode register, the pull-up MOS for that pin is disabled.

## **LCD Circuit**

The MCU incorporates a controller and driver that drive four common signal pins and 32 segment pins (24 segment pins in the HD404868 Series). The controller unit consists of a RAM unit that stores the display data, a display control register (LCR), and a duty/clock control register (LMR) (figures 86-1 and 86-2).

The LCD circuit allows four different duties and LCD clocks to be controlled by the program, and also incorporates dual-port RAM, enabling display data to be transferred to the segment signal pins automatically without program processing. If the 32 kHz oscillator clock is designated as the LCD clock source, LCD display is also possible in watch mode in which the system clock stops.

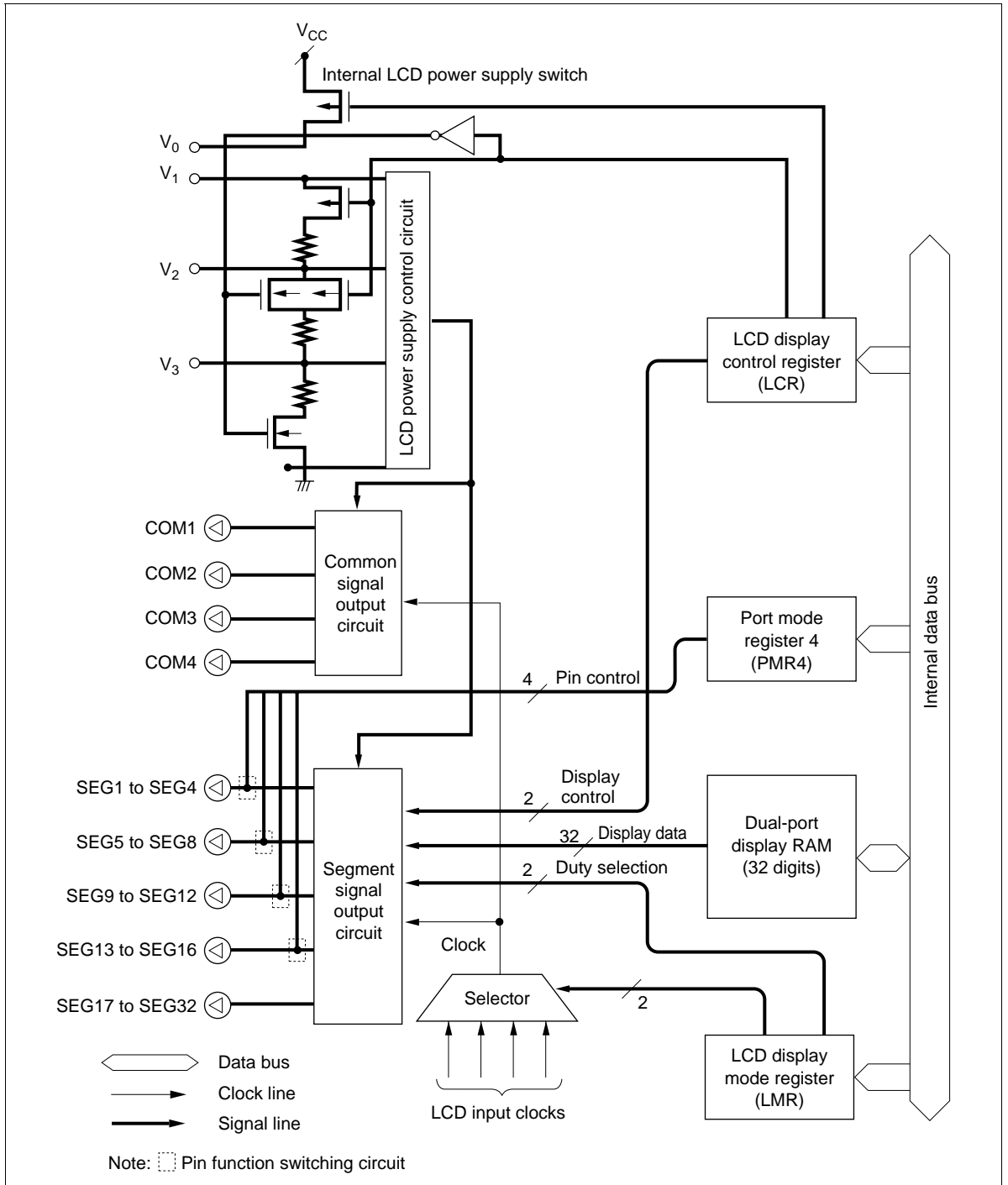


Figure 86-1 LCD Circuit Block Diagram (HD404889/HD404899/HD404878 Series)

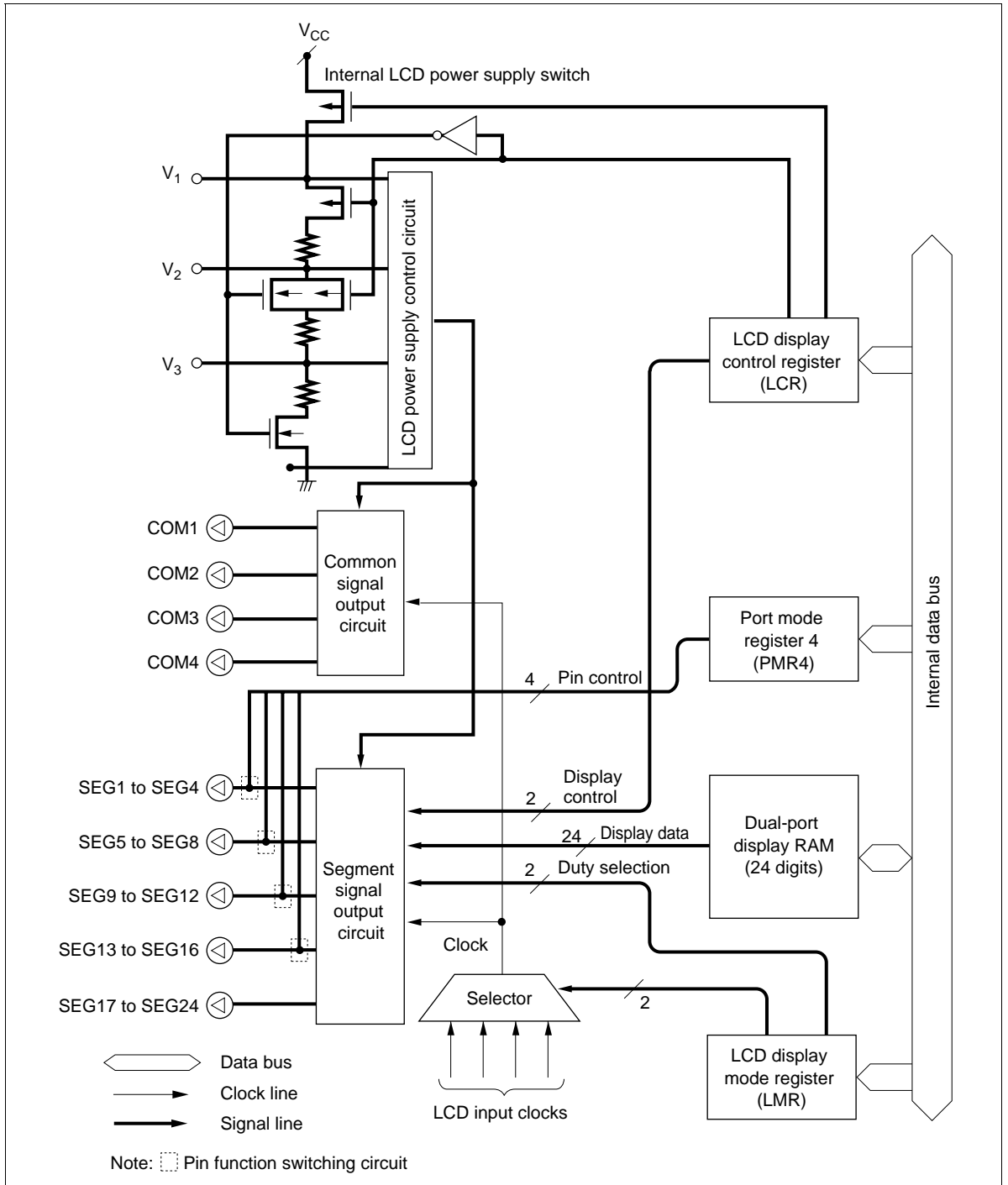


Figure 86-2 LCD Circuit Block Diagram (HD404868 Series)

# HD404889/HD404899/HD404878/HD404868 Series

## LCD data area and segment data: \$050 to \$06F (HD404889/HD404899/HD404878 Series) \$050 to \$067 (HD404868 Series)

Figures 87-1 and 87-2 show the LCD RAM area configuration. Each bit of the storage area corresponds to one of four duties. When data is written to the area corresponding to a particular duty, it is automatically output to the segment as display data.

	bit3	bit2	bit1	bit0		bit3	bit2	bit1	bit0
\$050	SEG1	SEG1	SEG1	SEG1	\$060	SEG17	SEG17	SEG17	SEG17
\$051	SEG2	SEG2	SEG2	SEG2	\$061	SEG18	SEG18	SEG18	SEG18
\$052	SEG3	SEG3	SEG3	SEG3	\$062	SEG19	SEG19	SEG19	SEG19
\$053	SEG4	SEG4	SEG4	SEG4	\$063	SEG20	SEG20	SEG20	SEG20
\$054	SEG5	SEG5	SEG5	SEG5	\$064	SEG21	SEG21	SEG21	SEG21
\$055	SEG6	SEG6	SEG6	SEG6	\$065	SEG22	SEG22	SEG22	SEG22
\$056	SEG7	SEG7	SEG7	SEG7	\$066	SEG23	SEG23	SEG23	SEG23
\$057	SEG8	SEG8	SEG8	SEG8	\$067	SEG24	SEG24	SEG24	SEG24
\$058	SEG9	SEG9	SEG9	SEG9	\$068	SEG25	SEG25	SEG25	SEG25
\$059	SEG10	SEG10	SEG10	SEG10	\$069	SEG26	SEG26	SEG26	SEG26
\$05A	SEG11	SEG11	SEG11	SEG11	\$06A	SEG27	SEG27	SEG27	SEG27
\$05B	SEG12	SEG12	SEG12	SEG12	\$06B	SEG28	SEG28	SEG28	SEG28
\$05C	SEG13	SEG13	SEG13	SEG13	\$06C	SEG29	SEG29	SEG29	SEG29
\$05D	SEG14	SEG14	SEG14	SEG14	\$06D	SEG30	SEG30	SEG30	SEG30
\$05E	SEG15	SEG15	SEG15	SEG15	\$06E	SEG31	SEG31	SEG31	SEG31
\$05F	SEG16	SEG16	SEG16	SEG16	\$06F	SEG32	SEG32	SEG32	SEG32
	COM4	COM3	COM2	COM1		COM4	COM3	COM2	COM1

**Figure 87-1 LCD RAM Area Configuration (Using Dual-Port RAM)  
(HD404889/HD404899/HD404878 Series)**

	bit3	bit2	bit1	bit0		bit3	bit2	bit1	bit0
\$050	SEG1	SEG1	SEG1	SEG1	\$060	SEG17	SEG17	SEG17	SEG17
\$051	SEG2	SEG2	SEG2	SEG2	\$061	SEG18	SEG18	SEG18	SEG18
\$052	SEG3	SEG3	SEG3	SEG3	\$062	SEG19	SEG19	SEG19	SEG19
\$053	SEG4	SEG4	SEG4	SEG4	\$063	SEG20	SEG20	SEG20	SEG20
\$054	SEG5	SEG5	SEG5	SEG5	\$064	SEG21	SEG21	SEG21	SEG21
\$055	SEG6	SEG6	SEG6	SEG6	\$065	SEG22	SEG22	SEG22	SEG22
\$056	SEG7	SEG7	SEG7	SEG7	\$066	SEG23	SEG23	SEG23	SEG23
\$057	SEG8	SEG8	SEG8	SEG8	\$067	SEG24	SEG24	SEG24	SEG24
\$058	SEG9	SEG9	SEG9	SEG9					
\$059	SEG10	SEG10	SEG10	SEG10					
\$05A	SEG11	SEG11	SEG11	SEG11					
\$05B	SEG12	SEG12	SEG12	SEG12					
\$05C	SEG13	SEG13	SEG13	SEG13					
\$05D	SEG14	SEG14	SEG14	SEG14					
\$05E	SEG15	SEG15	SEG15	SEG15					
\$05F	SEG16	SEG16	SEG16	SEG16					
	COM4	COM3	COM2	COM1		COM4	COM3	COM2	COM1

**Figure 87-2 LCD RAM Area Configuration (Using Dual-Port RAM) (HD404868 Series)**

**LCD control register (LCR: \$02C):**

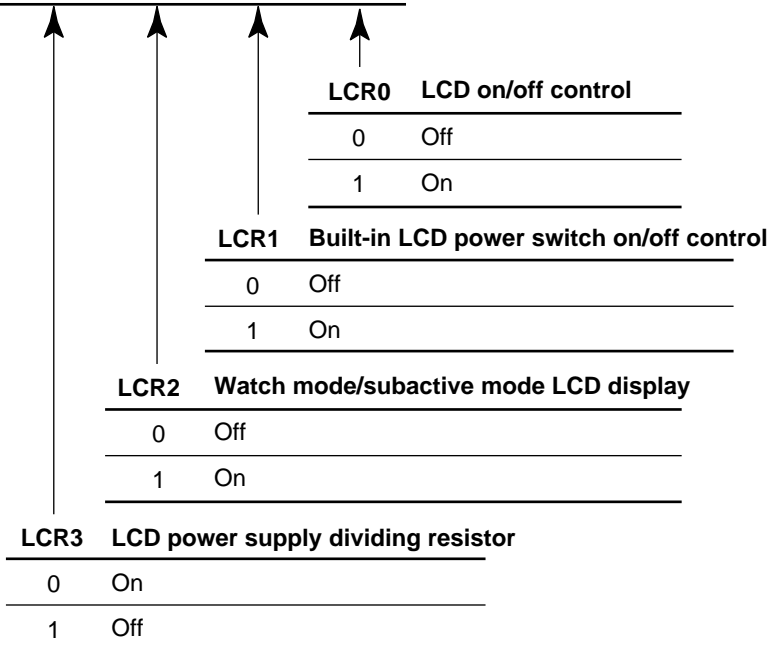
The LCD control register is a 4-bit write-only register that controls LCD blanking, the on/off state of the LCD power switch, display in watch mode and subactive mode, and disconnection of the LCD power supply dividing resistor, as shown in figure 88.

Individual bit in this register can be set and reset by bit manipulation instructions.

- Display on/off control
  - Off: Segment signals are in the off state, regardless of LCD RAM data.
  - On: LCD RAM data is output as segment signals.
- Built-in power switch on/off control
  - Off: The built-in LCD power switch is off.
  - On: The built-in LCD power switch is on. If V0 and V1 are shorted externally, V1 goes to the  $V_{CC}$  level.
- LCD display in watch mode and subactive mode
  - Off: In watch mode and subactive mode, all common and segment pins are fixed at GND potential. The built-in LCD power switch is off.
  - On: In watch mode and subactive mode, LCD RAM data is output as segment signals.
- LCD power supply dividing resistor switch on/off control
  - Off: The built-in LCD power supply dividing resistor is disconnected.
  - On: The built-in LCD power supply dividing resistor is connected.

LCD control register (LCR: \$02C)

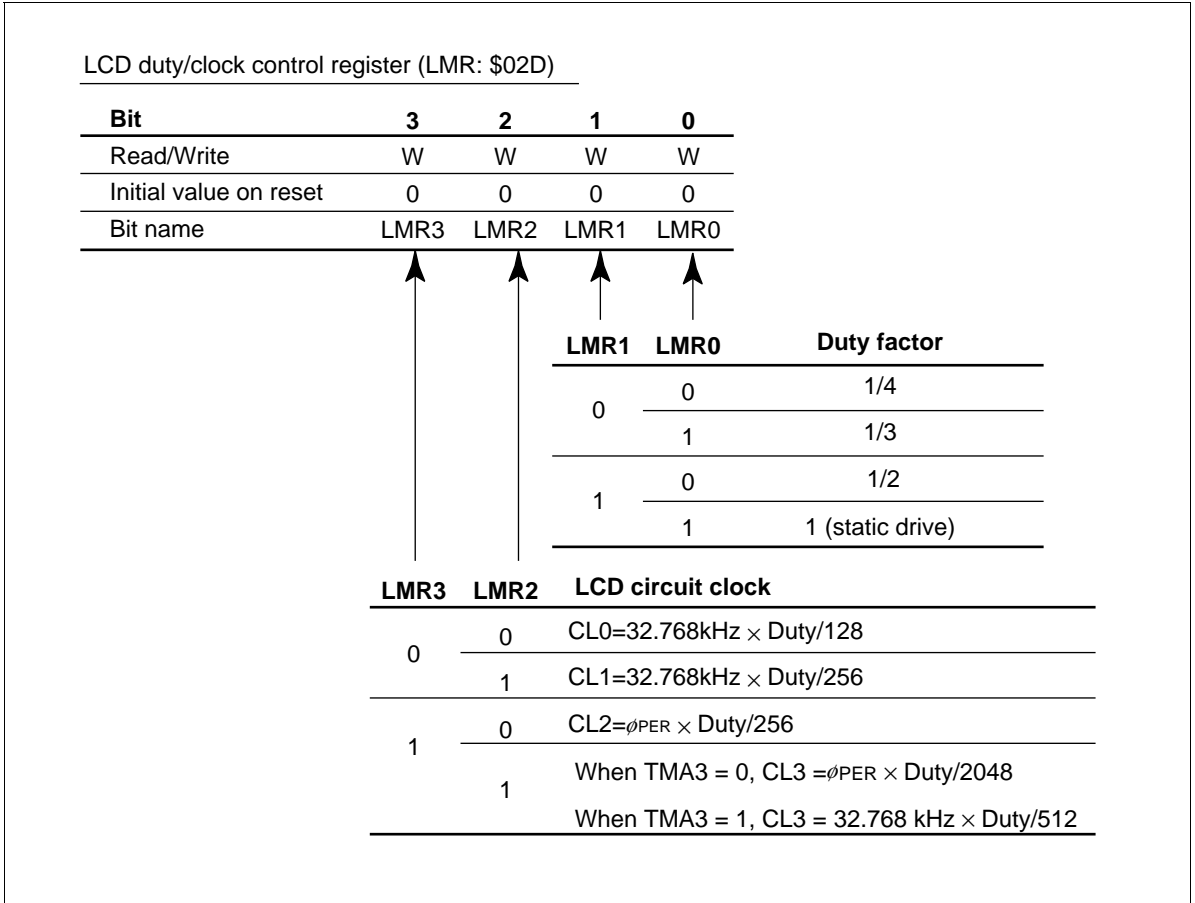
Bit	3	2	1	0
Read/Write	W	W	W	W
Initial value on reset	0	0	0	0
Bit name	LCR3	LCR2	LCR1	LCR0



**Figure 88 LCD Control Register (LCR)**

**LCD duty/clock control register (LMR: \$02D):**

The LCD duty/clock control register is a 4-bit write-only register used to set four kinds of display duty ratio and LCD reference clock (figure 89). Table 27 shows the LCD frame frequencies for each duty setting.



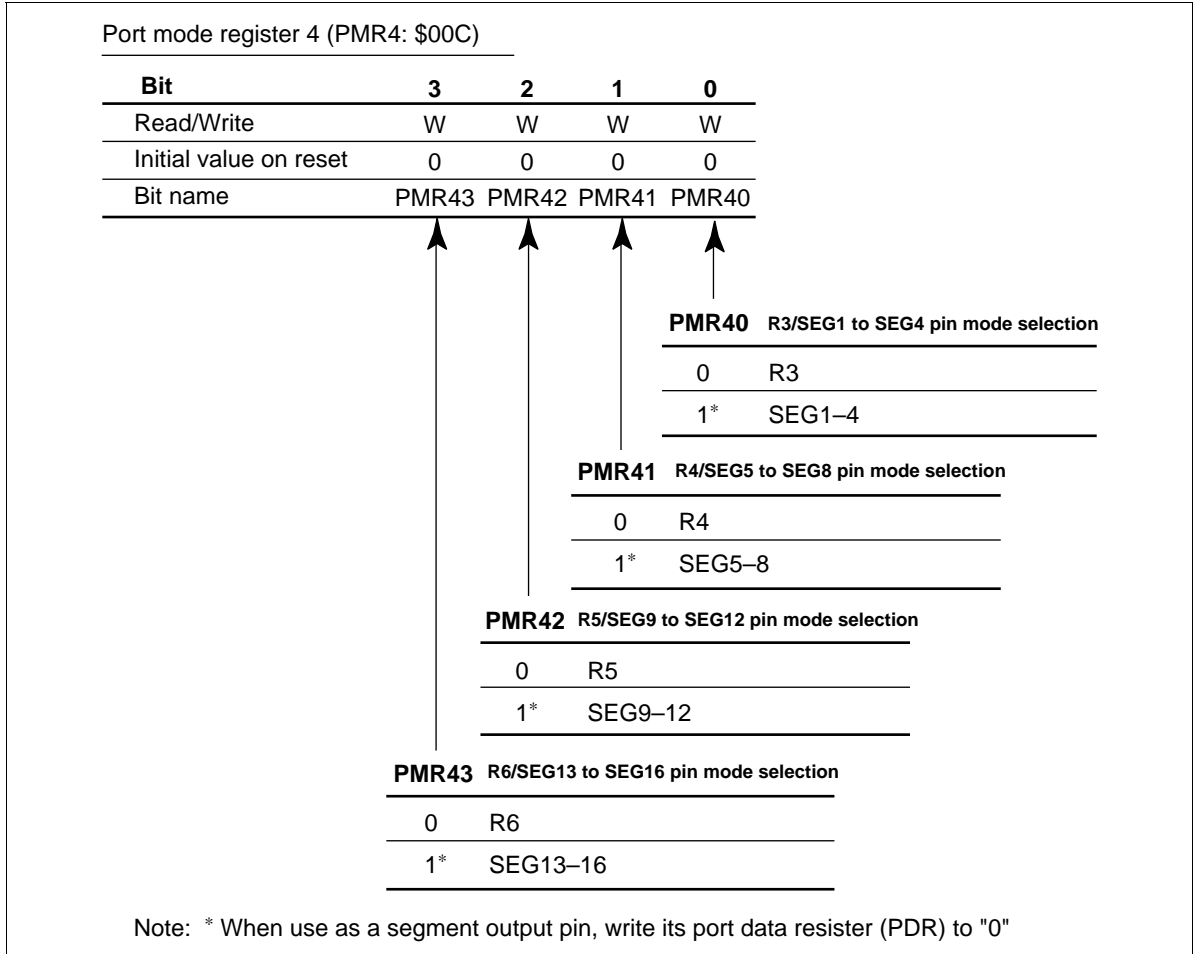
**Figure 89 LCD Duty/Clock Control Register (LMR)**

**Table 27 LCD Frame Frequencies for Each Duty Setting**

Duty	LMR3	LMR2		Frame Period							
				fosc=400kHz		fosc=800kHz		fosc=2.0MHz		fosc=4.0MHz	
				Division by 4	Division by 32	Division by 4	Division by 32	Division by 4	Division by 32	Division by 4	Division by 32
Static	0	0	CL0	256Hz							
		1	CL1	128Hz							
	1	0	CL2	390.6Hz	48.8Hz	781.3Hz	97.7Hz	1953Hz	244.1Hz	3906Hz	488.3Hz
		1	CL3*	48.8Hz	6.1Hz	97.7Hz	12.2Hz	244.1Hz	30.5Hz	488.3Hz	61.0Hz
1/2	0	0	CL0	128Hz							
		1	CL1	64Hz							
	1	0	CL2	195.3Hz	24.4Hz	390.6Hz	48.8Hz	976.6Hz	122.1Hz	1953Hz	244.1Hz
		1	CL3*	24.4Hz	3.1Hz	48.8Hz	6.1Hz	122.1Hz	15.3Hz	244.1Hz	30.5Hz
1/3	0	0	CL0	85.3Hz							
		1	CL1	42.7Hz							
	1	0	CL2	130.1Hz	16.3Hz	260.2Hz	32.5Hz	650Hz	81.3Hz	1301Hz	162.6Hz
		1	CL3*	16.3Hz	2.0Hz	32.5Hz	4.1Hz	81.3Hz	10.2Hz	162.6Hz	20.3Hz
1/4	0	0	CL0	64Hz							
		1	CL1	32Hz							
	1	0	CL2	97.7Hz	12.2Hz	195.3Hz	24.4Hz	488.3Hz	61.0Hz	976.6Hz	122.1Hz
		1	CL3*	12.2Hz	1.5Hz	24.4Hz	3.1Hz	61.0Hz	7.6Hz	122.1Hz	15.3Hz

## Port mode register 4 (PMR4: \$00C):

Port mode register 4 (PMR4) is a 4-bit write-only register that enables the R3 to R6 port pins to be switched to SEG1 to SEG16 pin functions in 4-port units (figure 90).



**Figure 90 Port Mode Register 4 (PMR4: \$00C)**

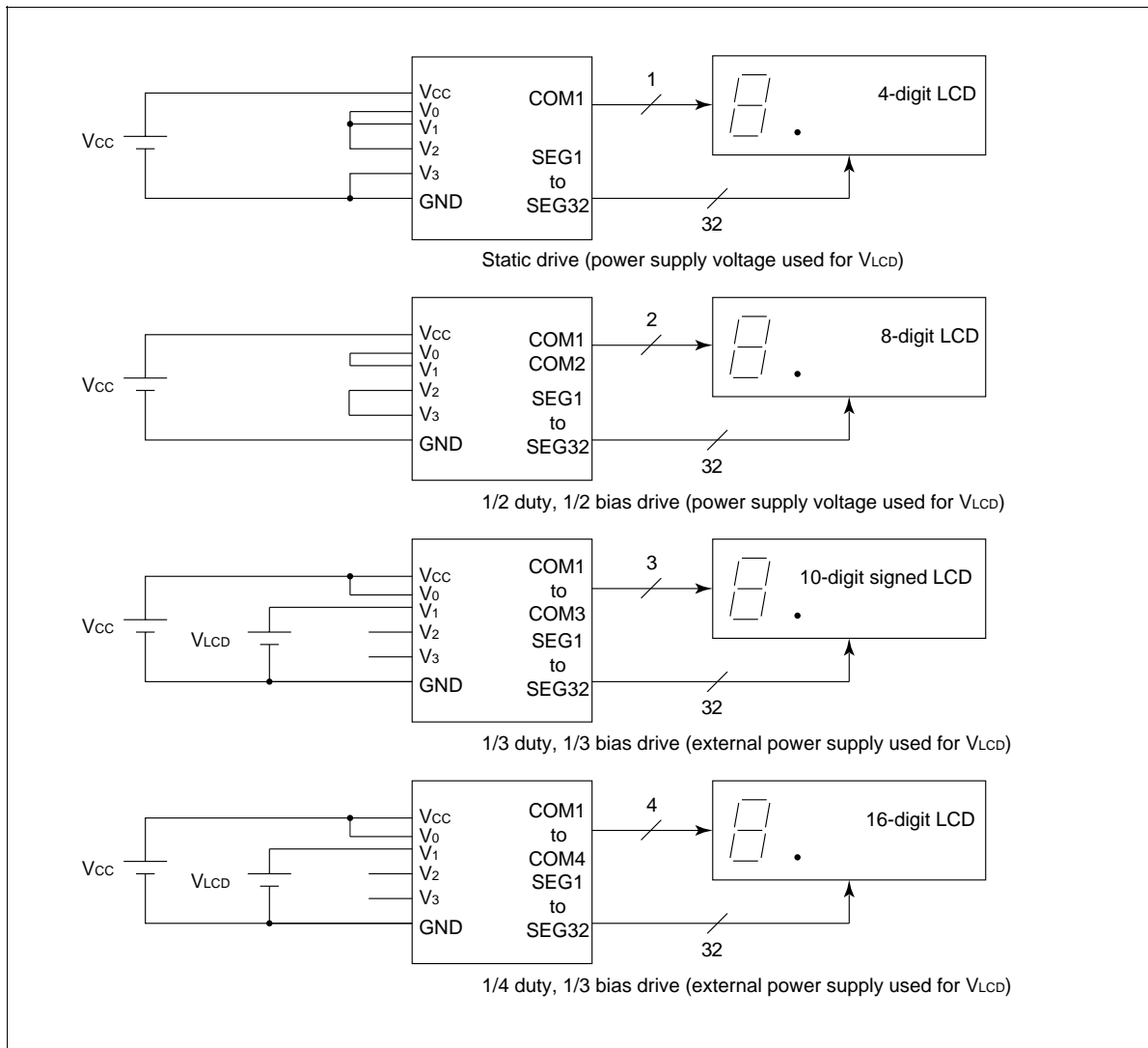
## LCD drive voltage ( $V_{LCD}$ ):

Example of LCD drive power supply wiring are shown in figures 91-1 and 91-2. The LCD drive voltage ( $V_{LCD}$ ) should be within the following range.

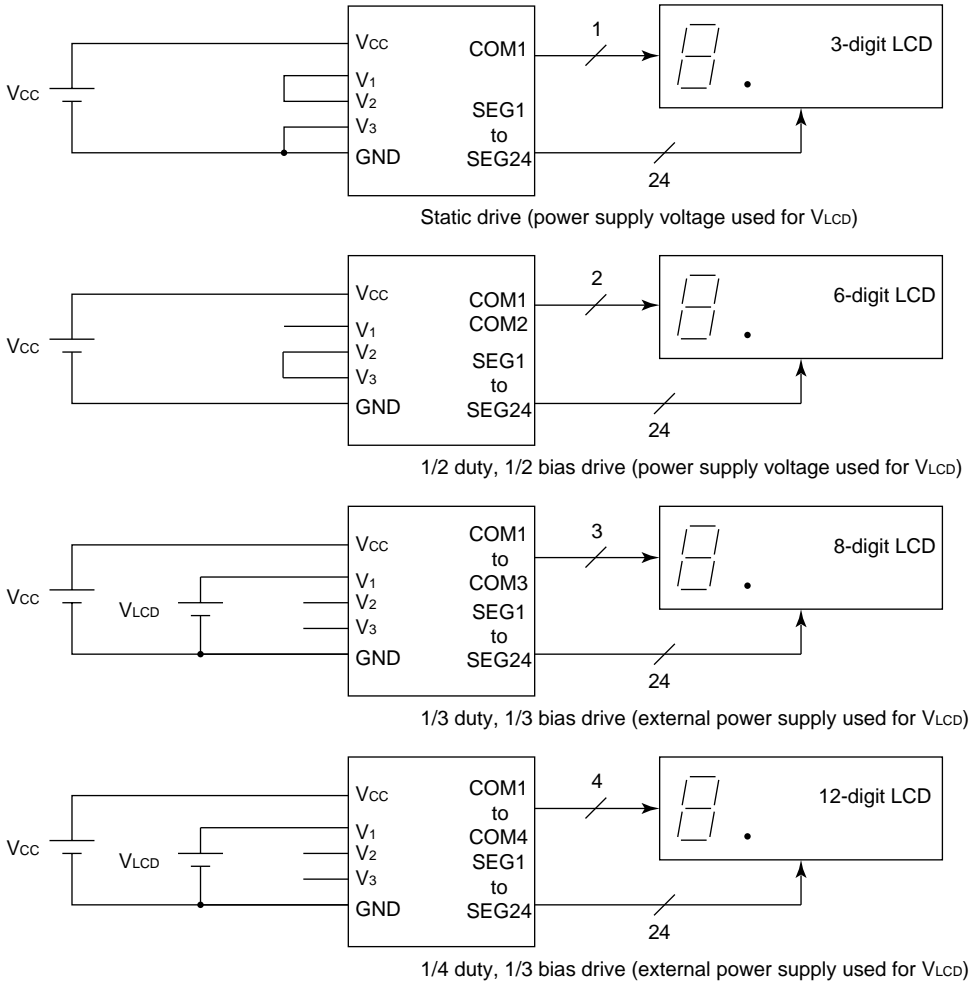
$$2.2 \leq V_{LCD} \leq V_{CC} \text{ (V)}$$

If the LCD drive voltage is applied from off-chip, connect the V0 pin to  $V_{CC}$  and turn the LCD power switch (LCD control register) off. (HD404889/HD404899/HD404878 Series)

When the power supply voltage is used as the LCD drive voltage, the V0 and V1 pins should be shorted. (HD404889/HD404899/HD404878 Series)



**Figure 91-1 Examples of LCD Wiring (HD404889/HD404899/HD404878 Series)**



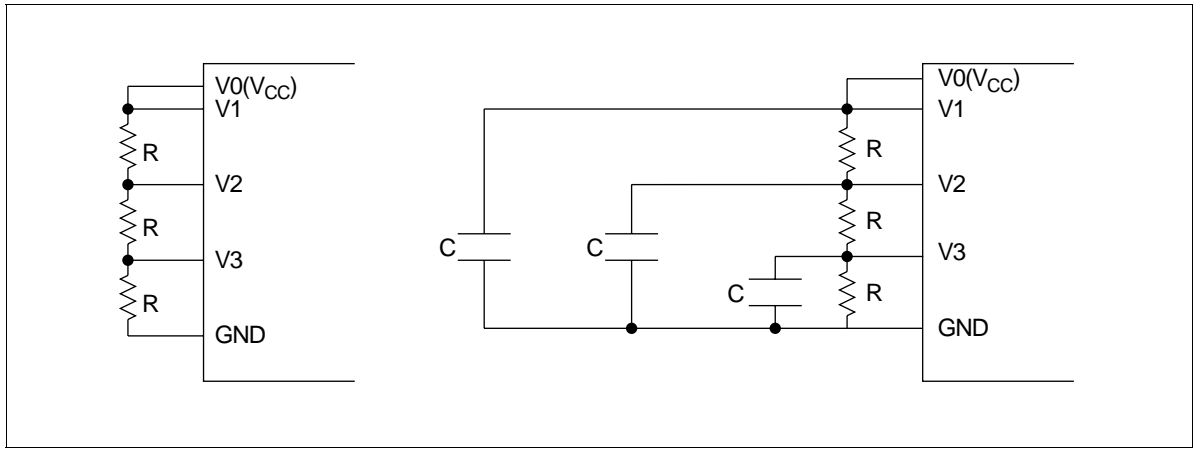
**Figure 91-2 Examples of LCD Wiring (HD404868 Series)**

**Large LCD panel drive:**

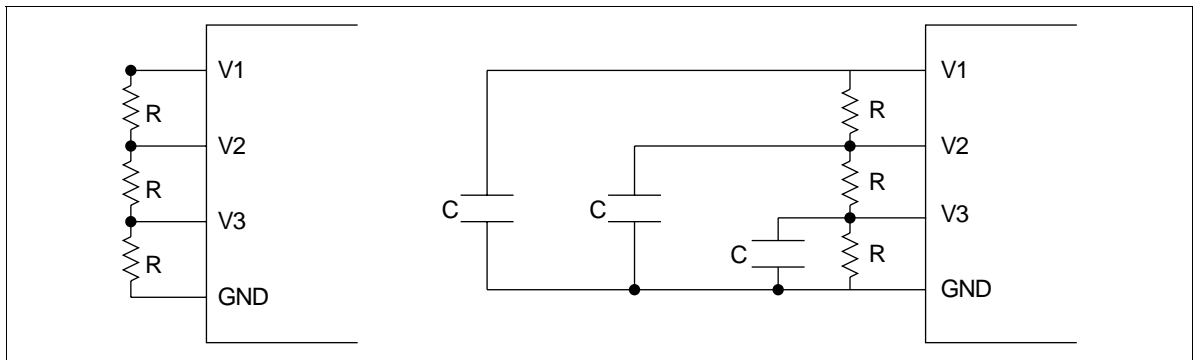
If the capacitance of the driven LCD is large, the value of the divided resistance should be reduced by dividing the resistance in parallel with the built-in divided resistor (see figures 92-1 and 92-2).

As an LCD has a matrix structure, the path of the charge/discharge current flowing to the load capacitance is complicated. Moreover, the current varies depending on the illumination state, so that it is not possible to determine the resistance values simply from the LCD load capacitance. The resistance values must therefore be determined experimentally in accordance with the power consumption requirement of the equipment, including the LCD. (Adding capacitors C with a value of 0.1 to 0.3  $\mu\text{F}$  is also effective).

A value of 1 k $\Omega$  to 10 k $\Omega$  is normally set for R.



**Figure 92-1 Large LCD Panel Drive (Using Power Supply Voltage for  $V_{LCD}$ )  
(HD404889/HD404899/HD404878 Series)**



**Figure 92-2 Large LCD Panel Drive (Using Power Supply Voltage for  $V_{LCD}$ ) (HD404868 Series)**

**Usage Notes**

When R3<sub>0</sub>/SEG1 to R6<sub>0</sub>/SEG16 pins are used as segment output pins, write their port data register (PDR) to “0”.

## Buzzer Output Circuit

**Buzzer Output Circuit Functions:** The buzzer output circuit has the following functions.

- Timer overflow toggle output
- System clock divided clock pulse output

The block diagram of the buzzer output circuit is shown in figure 93.

### Buzzer Output Circuit Operation

- Timer overflow toggle output operation

The timer overflow toggle output operation setting is made by bits 1 and 2 of the buzzer mode register (BMR) and bit 2 of port mode register 2 (PMR2). By clearing bit 2 of the buzzer mode register (BMR) to 0, selecting timer B or timer C overflow by bit 1, and setting bit 2 of port mode register 2 (PMR2) to 1, a toggle waveform is output from the BUZZ pin with overflow as the trigger.

- System clock divided clock pulse output

The system clock divided clock pulse output operation setting is made by bits 0 to 3 of the buzzer mode register (BMR) and bit 2 of port mode register 2 (PMR2). Bit 2 of the buzzer mode register (BMR) is set to 1, the system clock division ratio is selected by bits 0 and 1, and bit 2 of port mode register 2 (PMR2) is set to 1. Clock pulses are output by setting bit 3 of the buzzer mode register (BMR) to 1. If bit 3 of the buzzer mode register (BMR) is cleared to 0, the BUZZ pin goes low.

The clock pulse width is fixed without regard to the timing set by bit 3 of the buzzer mode register (BMR), and careful coordination with software is necessary with regard to the number of output pulses. After a clock pulse modification is made, clock pulses should not be output until 4tcyc after the modifying instruction.

Only a bit manipulation instruction can be used on bit 3 of the buzzer mode register (BMR).

### Buzzer Output Circuit Registers

Buzzer output circuit operation setting is performed by the following registers.

Buzzer mode register (BMR: \$02E)

Port mode register 2 (PMR2: \$00A)

#### **Buzzer mode register (BMR: \$02E):**

The buzzer mode register (BMR) is a 4-bit write-only register used to set toggle output by timer overflow and system clock divided clock pulse output as shown in figure 94.

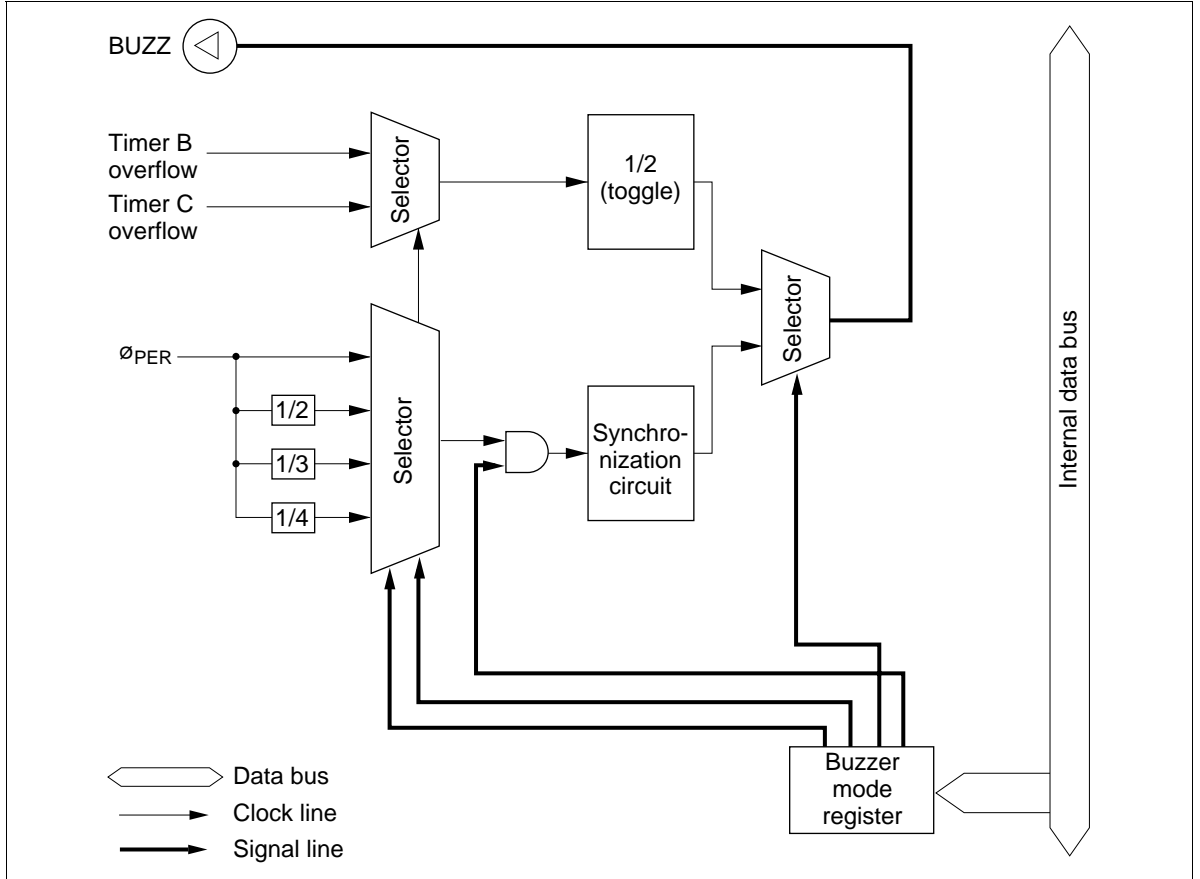
Bit 3 of the buzzer mode register (BMR) can only be accessed by a bit manipulation instruction.

The buzzer mode register (BMR) is reset to \$0 by an MCU reset.

**Port mode register 2 (PMR2: \$00A):**

Port mode register 2 (PMR2) is a 4-bit write-only register used to switch the R1<sub>2</sub>/BUZZ pin function as shown in figure 30.

Port mode register 2 (PMR2) is reset to \$0 by an MCU reset.



**Figure 93 Buzzer Output Circuit**

Buzzer mode register (BMR: \$02E)

Bit	3	2	1	0
Read/Write	W	W	W	W
Initial value on reset	0	0	0	0
Bit name	BMR3	BMR2	BMR1	BMR0

	BMR2	BMR1	BMR0	BUZZ pin output
0	0	0	*	Division by 2 of timer B overflow
		1	*	Division by 2 of timer C overflow
1	0	0	0	$\emptyset$ PER clock
			1	$\emptyset$ PER/2clock
		1	0	$\emptyset$ PER/3clock
			1	$\emptyset$ PER/4clock

\* : Don't care

Clock output control (enabled when BMR2 = 1, bit manipulation instruction)

0	Stopped (low level)
1	Output

**Figure 94 Buzzer Mode Register (BMR)**

## **ZTAT™ Microcomputer with Built-in Programmable ROM**

### **1. Precautions for use of ZTAT™ microcomputer with built-in programmable ROM**

#### **(1) Precautions for writing to programmable ROM built in ZTAT™ microcomputer**

In the ZTAT™ microcomputer with built-in plastic mold one-time programmable ROM, incomplete electrical connection between the PROM writer and socket adapter causes writing errors and, makes the computer unoperatable. To enhance the writing efficiency, attention should be paid to the following points:

- (a) Make sure that the socket adapter is firmly fixed to the PROM writer and connected electrically with each other (neither opened nor shorted), before starting the writing process.
- (b) To secure the electrical connection between the contact pin and IC lead, make sure that there is no foreign substance on the contact pin of the socket adapter, which may cause improper electrical connection.
- (c) When inserting the IC, be careful to protect the IC lead from bending in order to secure the electrical connection between the contact pin and IC lead. If the lead is bent, correct the bending and insert it again.
- (d) If any trouble is noticed during a blank check to be performed to prevent erroneous writing due to improper electrical connection, carry out the writing process again according to above steps (a), (b), and (c).
- (e) During the writing process, do not touch the socket adapter and IC to prevent erroneous writing.
- (f) To write continuously in the IC, follow steps (a), (b), (c), (d) and (e).
- (g) If a writing error recurs, or the rate of writing errors occur frequently, stop writing and check the PROM writer, socket adapter, etc. for defects.
- (h) If any problem is noticed in the written program or in the program after being left at a high temperature, consult our technical staff.

#### **(2) Precautions when new PROM writer, socket adapter or IC is used**

When a new PROM writer, socket adapter or IC is employed, breakdown of the IC may occur or its writing may become impossible because the noise, overshoot, timing or other electrical characteristics may be inconsistent with the assured IC writing characteristics. To avoid such troubles, check the following points before starting the writing process.

- (a) To ensure stable writing operation, check that the  $V_{CC}$  of the power supplied to the PROM writer, power source current capacity of  $V_{PP}$ , and current consumption at the time of writing to IC are provided with sufficient margin.
- (b) To prevent breakdown of the IC, check that the power source voltage between  $GND-V_{CC}$  and  $GND-V_{PP}$ , and overshoot or undershoot of the power source at the connecting terminal of the socket adapter are within the ratings. Particularly, if the overshoot or undershoot exceeds the maximum rating, the p-n connection may be damaged, leading to permanent breakdown. If overshoot or undershoot occurs, recheck the power source damping resistance of capacity.
- (c) To prevent breakdown of the IC and for stable writing and reading operation, insert the IC into the socket adapter and check the power noise between the  $GND-V_{CC}$  and  $GND-V_{PP}$  near the IC connecting

terminal. If power source noise is noticed, insert an appropriate capacitor between the GND power sources depending on the noise generated. In case of high frequency noise, insert a capacitor of low inductance.

- (d) For stable writing and reading operation, insert the IC into the socket adapter and check the input waveform, timing and noise near the R/W, CS, address and data terminals. Particularly, since recent ICs have increased in speed, caution should be exercised against the noise to the power source or address due to crosstalk from the output data terminal. To avoid these problems, inserting a low inductance capacitor between the GND and power source or inserting a damping resistance to the output data terminal is effective.
- (e) Particularly, when a multiple PROM writer is used, perform above items (a), (b), (c), and (d) assuming all ICs inserted into the socket adapter.
- (f) In the case of a multiple PROM writer, when an unacceptable result is noticed during a blank check performed to prevent erroneous writing due to improper electrical connection of the power source, etc., rewriting is impossible unless every writing process can be stopped. Therefore, the potential increases due to erroneous writing because of improper connection. Be sure to check the electrical connection between the PROM writer and socket adapter and IC.
- (g) If any abnormality is noticed while checking a written program, consult our technical staff.

## 2. Programming of Built-in programmable ROM

The MCU can stop its function as an MCU in PROM mode for programming the built-in PROM.

PROM mode is set by driving the  $\overline{\text{RESET}}$ ,  $\overline{\text{M}}_0$ , and  $\overline{\text{M}}_1$  pins low (or by driving the  $\overline{\text{RESET}}$  and  $\overline{\text{M}}_0$  pins low in the HD4074869), and driving the TEST pin to the  $V_{pp}$  level.

Writing and reading specifications of the PROM are the same as those for the commercial EPROM27256. Using a socket adapter for specific use of each product, programming is possible with a general-purpose PROM writer.

Since an instruction of the HMCS400 series is 10 bits long, a conversion circuit is incorporated to adapt the general-purpose PROM writer. This circuit splits each instruction into five lower bits and five higher bits to write from or read to two addresses. This enables use of a general-purpose PROM. For instance, to write to a 16kword of built-in PROM writer with a general-purpose PROM, specify 32kbyte address (\$0000-\$7FFF). An example of PROM memory map is shown in figure 95.

### Notes:

1. When programming with a PROM writer, set up each ROM size to the address given in table 30. If it is programmed erroneously to an address given in table 30 or later, check of writing of PROM may become impossible. Particularly, caution should be exercised in the case of a plastic package since reprogramming is impossible with it. Set the data in unused addresses to \$FF.
2. If the indexes of the PROM writer socket, socket adapter and product are not aligned precisely, the product may break down due to overcurrent. Be sure to check that they are properly set to the writer before starting the writing process.

3. Two levels of program voltages ( $V_{PP}$ ) are available for the PROM: 12.5V and 21V. Our product employs a  $V_{PP}$  of 12.5V. If a voltage of 21V is applied, permanent breakdown of the product will result. The  $V_{PP}$  of 12.5V is obtained for the PROM writer by setting it according to the Intel 27258 specifications.

**Table 28 Socket Adapters**

Package	Model Name	Manufacturer
FP-80A	Please ask Hitachi service section.	
TFP-80C	Please ask Hitachi service section.	
FP-64A	Please ask Hitachi service section.	
DP-64S	Please ask Hitachi service section.	

## Writing/verification

Programming of the built-in program ROM employs a high speed programming method. With this method, high speed writing is effected without voltage stress to the device or without damaging the reliability of the written data.

A basic programming flow chart is shown in figure 96 and a timing chart in figure 97.

For precautions for PROM writing procedure, refer to Section 2, "Characteristics of ZTAT™ Microcomputer's Built-in Programmable ROM and precautions for its Applications."

**Table 29 Selection of Mode**

Mode	CE	OE	$V_{PP}$	$O_0$ to $O_4$
Writing	"Low"	"High"	$V_{PP}$	Data input
Verification	"High"	"Low"	$V_{PP}$	Data output
Prohibition of programming	"High"	"High"	$V_{PP}$	High impedance

**Table 30 PROM Writer Program Address**

ROM size	Address
8k	\$0000~\$3FFF
12k	\$0000~\$5FFF
16k	\$0000~\$7FFF

# HD404889/HD404899/HD404878/HD404868 Series

## Programmable Rom (HD4074889, HD4074899, HD4074869)

The HD4074889, HD4074899, and HD4074869 are a ZTAT™ microcomputers with built-in PROM that can be programmed in PROM mode.

### PROM Mode Pin Description

HD4074889, HD4074899

Pin No.	MCU Mode		PROM Mode	
	Pin Name	I/O	Pin Name	I/O
1	AV <sub>CC</sub>	—	V <sub>CC</sub>	—
2	R7 <sub>↓</sub> /AN0	I/O	V <sub>CC</sub>	—
3	R7 <sub>↓</sub> /AN1	I/O	V <sub>CC</sub>	—
4	R7 <sub>↓</sub> /AN2	I/O		
5	R7 <sub>↓</sub> /AN3	I/O		
6	R8 <sub>↓</sub> /AN4	I/O		
7	R8 <sub>↓</sub> /AN5	I/O		
8	AV <sub>SS</sub>	—	GND	—
9	TEST	I	V <sub>PP</sub>	—
10	OSC1	I	V <sub>CC</sub>	—
11	OSC2	O		
12	GND	—	GND	—
13	X2	O		
14	X1	I	GND	—
15	RESET	I	RESET	I
16	V <sub>CC</sub>	—	V <sub>CC</sub>	—
17	D <sub>i</sub> /INT <sub>0</sub>	I/O	A <sub>n</sub>	I
18	D <sub>i</sub> /INT <sub>1</sub>	I/O		
19	D <sub>2</sub>	I/O	A <sub>6</sub>	I
20	D <sub>3</sub>	I/O	A <sub>6</sub>	I
21	D <sub>4</sub>	I/O	A <sub>7</sub>	I
22	D <sub>5</sub>	I/O	A <sub>8</sub>	I
23	D <sub>6</sub>	I/O	A <sub>9</sub>	I
24	D <sub>7</sub>	I/O	A <sub>10</sub>	I
25	D <sub>8</sub>	I/O	A <sub>11</sub>	I
26	D <sub>9</sub>	I/O	A <sub>12</sub>	I
27	D <sub>10</sub>	I/O	A <sub>13</sub>	I
28	D <sub>11</sub>	I/O	A <sub>14</sub>	I
29	R0 <sub>↓</sub> /WU <sub>0</sub>	I/O	V <sub>CC</sub>	—
30	R0 <sub>↓</sub> /WU <sub>1</sub>	I/O		
31	R0 <sub>↓</sub> /WU <sub>2</sub>	I/O		
32	R0 <sub>↓</sub> /WU <sub>3</sub>	I/O		
33	R1 <sub>↓</sub> /EVNB	I/O		
34	R1 <sub>↓</sub> /EVND	I/O	M0	I
35	R1 <sub>↓</sub> /BUZZ	I/O	M1	I
36	R1 <sub>↓</sub> /TOB	I/O	CE	I
37	R2 <sub>↓</sub> /TOC	I/O		
38	R2 <sub>↓</sub> /SCK	I/O	OE	I
39	R2 <sub>↓</sub> /SI/SO	I/O	XM0	O
40	R2 <sub>3</sub>	I/O	XM1	O

Pin No.	MCU Mode		PROM Mode	
	Pin Name	I/O	Pin Name	I/O
41	R3 <sub>↓</sub> /SEG1	I/O	A <sub>1</sub>	I
42	R3 <sub>↓</sub> /SEG2	I/O	A <sub>2</sub>	I
43	R3 <sub>↓</sub> /SEG3	I/O	A <sub>3</sub>	I
44	R3 <sub>↓</sub> /SEG4	I/O	A <sub>4</sub>	I
45	R4 <sub>↓</sub> /SEG5	I/O	O <sub>0</sub>	I/O
46	R4 <sub>↓</sub> /SEG6	I/O	O <sub>1</sub>	I/O
47	R4 <sub>↓</sub> /SEG7	I/O	O <sub>2</sub>	I/O
48	R4 <sub>↓</sub> /SEG8	I/O	O <sub>3</sub>	I/O
49	R5 <sub>↓</sub> /SEG9	I/O	O <sub>4</sub>	I/O
50	R5 <sub>↓</sub> /SEG10	I/O	O <sub>4</sub>	I/O
51	R5 <sub>↓</sub> /SEG11	I/O	O <sub>3</sub>	I/O
52	R5 <sub>↓</sub> /SEG12	I/O	O <sub>2</sub>	I/O
53	R6 <sub>↓</sub> /SEG13	I/O	O <sub>1</sub>	I/O
54	R6 <sub>↓</sub> /SEG14	I/O	O <sub>0</sub>	I/O
55	R6 <sub>↓</sub> /SEG15	I/O		
56	R6 <sub>↓</sub> /SEG16	I/O		
57	SEG17	O		
58	SEG18	O		
59	SEG19	O		
60	SEG20	O		
61	SEG21	O		
62	SEG22	O		
63	SEG23	O		
64	SEG24	O		
65	SEG25	O		
66	SEG26	O		
67	SEG27	O		
68	SEG28	O		
69	SEG29	O		
70	SEG30	O		
71	SEG31	O		
72	SEG32	O		
73	COM1	O		
74	COM2	O		
75	COM3	O		
76	COM4	O		
77	V3	—		
78	V2	—		
79	V1	—	V <sub>CC</sub>	—
80	V0	—	V <sub>CC</sub>	—

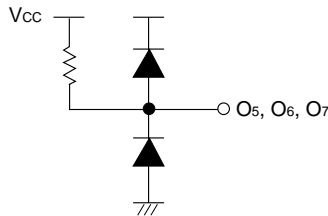
## HD4074869

Pin No.	MCU Mode	PROM Mode			
FP-64A	DP-64S	Pin Name	I/O	Pin Name	I/O
1	8	R7 <sub>7</sub> /AN0	I/O	V <sub>CC</sub>	—
2	9	R7 <sub>7</sub> /AN1	I/O	V <sub>CC</sub>	—
3	10	R7 <sub>7</sub> /AN2	I/O		
4	11	R7 <sub>7</sub> /AN3	I/O		
5	12	TEST	I	V <sub>PP</sub>	—
6	13	OSC1	I	V <sub>CC</sub>	—
7	14	OSC2	O		
8	15	GND	—	GND	—
9	16	X2	O		
10	17	X1	I	GND	—
11	18	RESET	I	RESET	I
12	19	V <sub>CC</sub>	—	V <sub>CC</sub>	—
13	20	D <sub>0</sub> /INT <sub>0</sub>	I/O	A <sub>0</sub>	I
14	21	D <sub>1</sub> /INT <sub>1</sub>	I/O		
15	22	D <sub>2</sub>	I/O	A <sub>5</sub>	I
16	23	D <sub>3</sub>	I/O	A <sub>6</sub>	I
17	24	D <sub>4</sub>	I/O	A <sub>7</sub>	I
18	25	D <sub>5</sub>	I/O	A <sub>8</sub>	I
19	26	D <sub>6</sub>	I/O	A <sub>9</sub>	I
20	27	D <sub>7</sub>	I/O	A <sub>10</sub>	I
21	28	D <sub>8</sub>	I/O	A <sub>11</sub>	I
22	29	D <sub>9</sub>	I/O	A <sub>12</sub>	I
23	30	R0 <sub>0</sub> /WU <sub>0</sub>	I/O	V <sub>CC</sub>	—
24	31	R0 <sub>0</sub> /WU <sub>1</sub>	I/O		
25	32	R0 <sub>0</sub> /WU <sub>2</sub>	I/O		
26	33	R1 <sub>1</sub> /EVNB	I/O		
27	34	R1 <sub>1</sub>	I/O	A <sub>13</sub>	I
28	35	R1 <sub>1</sub> /BUZZ	I/O	M0	I
29	36	R1 <sub>1</sub> /TOB	I/O	CE	I
30	37	R2 <sub>2</sub> /TOC	I/O	XM1	O
31	38	R2 <sub>2</sub> /SCKN	I/O	OE	I
32	39	R2 <sub>2</sub> /SI/SO	I/O	XM0	O

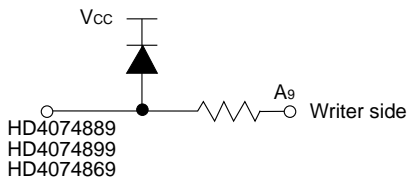
Pin No.	MCU Mode	PROM Mode			
FP-64A	DP-64S	Pin Name	I/O	Pin Name	I/O
33	40	R2 <sub>2</sub>	I/O	A <sub>14</sub>	I
34	41	R3 <sub>3</sub> /SEG1	I/O	A <sub>1</sub>	I
35	42	R3 <sub>3</sub> /SEG2	I/O	A <sub>2</sub>	I
36	43	R3 <sub>3</sub> /SEG3	I/O	A <sub>3</sub>	I
37	44	R3 <sub>3</sub> /SEG4	I/O	A <sub>4</sub>	I
38	45	R4 <sub>4</sub> /SEG5	I/O	O <sub>0</sub>	I/O
39	46	R4 <sub>4</sub> /SEG6	I/O	O <sub>1</sub>	I/O
40	47	R4 <sub>4</sub> /SEG7	I/O	O <sub>2</sub>	I/O
41	48	R4 <sub>4</sub> /SEG8	I/O	O <sub>3</sub>	I/O
42	49	R5 <sub>5</sub> /SEG9	I/O	O <sub>4</sub>	I/O
43	50	R5 <sub>5</sub> /SEG10	I/O	O <sub>4</sub>	I/O
44	51	R5 <sub>5</sub> /SEG11	I/O	O <sub>3</sub>	I/O
45	52	R5 <sub>5</sub> /SEG12	I/O	O <sub>2</sub>	I/O
46	53	R6 <sub>6</sub> /SEG13	I/O	O <sub>1</sub>	I/O
47	54	R6 <sub>6</sub> /SEG14	I/O	O <sub>0</sub>	I/O
48	55	R6 <sub>6</sub> /SEG15	I/O		
49	56	R6 <sub>6</sub> /SEG16	I/O		
50	57	SEG17	O		
51	58	SEG18	O		
52	59	SEG19	O		
53	60	SEG20	O		
54	61	SEG21	O		
55	62	SEG22	O		
56	63	SEG23	O		
57	64	SEG24	O		
58	1	COM1	O		
59	2	COM2	O		
60	3	COM3	O		
61	4	COM4	O		
62	5	V <sub>3</sub>	—		
63	6	V <sub>2</sub>	—		
64	7	V <sub>1</sub>	—	V <sub>CC</sub>	—

Notes: 1. I/O: I/O pin, I: Input-only pin, O: Output-only pin

- As there are two each of pins O<sub>0</sub> to O<sub>4</sub>, the respective pairs should be shorted.
- Unused data pins (O<sub>5</sub> to O<sub>7</sub>) on the PROM programmer side should be handled as shown below on the socket.



- Pin A<sub>9</sub> should be handled as shown below on the socket.



## 2. Pin Functions in PROM Mode

### $V_{PP}$ :

Applies the on-chip PROM programming voltage (12.5 V  $\pm$ 0.3 V).

### $\overline{CE}$ :

Inputs a control signal to set the on-chip PROM to the write/verify enabled state.

### $\overline{OE}$ :

Inputs a data output control signal during verification.

### $A_0$ to $A_{14}$ :

On-chip PROM address input pins.

### $O_0$ to $O_4$ :

On-chip PROM data bus I/O pins.

As there are two each of pins  $O_0$  to  $O_4$ , the respective pairs should be shorted.

### $\overline{M}_0$ , $\overline{M}_1$ , $\overline{RESET}$ , $\overline{TEST}$ :

PROM mode setting pins. PROM mode is set by driving the  $\overline{M}_0$ ,  $\overline{M}_1$ , and  $\overline{RESET}$  pins low (or by driving the  $\overline{M}_0$ , and  $\overline{RESET}$  pins low in the HD4074869), and driving the  $\overline{TEST}$  pin to the  $V_{PP}$  level.

### Other pins:

$V_{CC}$ ,  $AV_{CC}$ ,  $R7_0/AN_0$ ,  $R7_1/AN_1$ ,  $OSC_1$ ,  $V_0$ , and  $V_1$  should be connected to  $V_{CC}$  potential.

$GND$ ,  $AV_{SS}$ , and  $X1$  should be connected to  $GND$  potential.

Other pins should be left open.



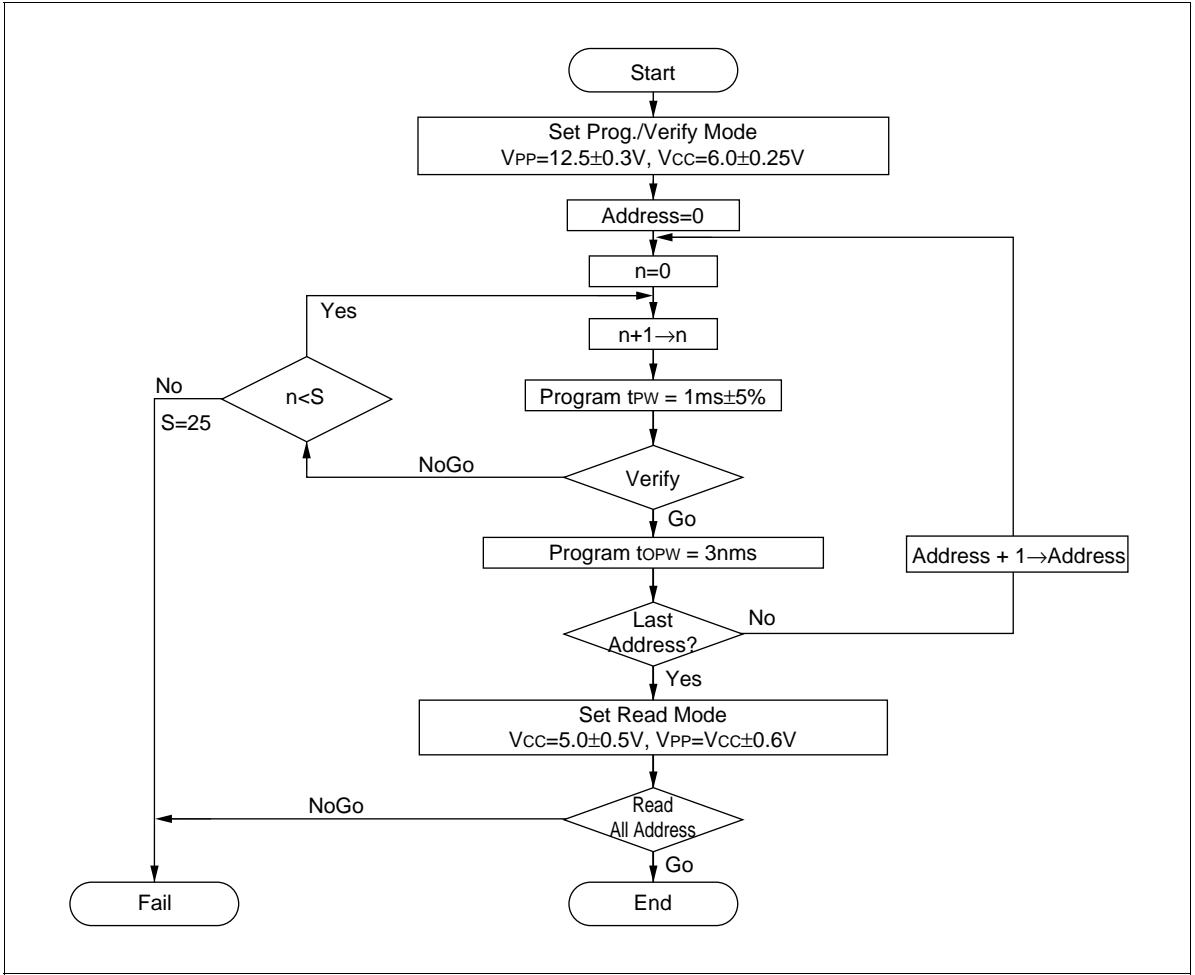


Figure 96 Flowchart of High-Speed Programming

## Programming Electrical Characteristics

**DC Characteristics** ( $V_{CC} = 6V \pm 0.25V$ ,  $V_{PP} = 12.5V \pm 0.3V$ ,  $V_{SS} = 0V$ ,  $T_a = 25^\circ C \pm 5^\circ C$ , unless otherwise specified)

Item	Symbol	Test Conditions	min	typ	max	Unit
Input high voltage	$O_0$ to $O_4$ , $A_0$ to $A_{14}$ , $\overline{OE}$ , $\overline{CE}$	$V_{IH}$	2.2	—	$V_{CC}+0.3$	V
Input low voltage	$O_0$ to $O_4$ , $A_0$ to $A_{14}$ , $\overline{OE}$ , $\overline{CE}$	$V_{IL}$	-0.3	—	0.8	V
Output high voltage	$O_0$ to $O_4$	$V_{OH}$ $I_{OH}=-200\mu A$	2.4	—	—	V
Output low voltage	$O_0$ to $O_4$	$V_{OL}$ $I_{OL}=1.6mA$	—	—	0.4	V
Input leakage current	$O_0$ to $O_4$ , $A_0$ to $A_{14}$ , $\overline{OE}$ , $\overline{CE}$	$ I_{IL} $ $V_{in}=5.25V/0.5V$	—	—	2	$\mu A$
$V_{CC}$ current		$I_{CC}$	—	—	30	mA
$V_{PP}$ current		$I_{PP}$	—	—	40	mA

**AC Characteristics** ( $V_{CC} = 6V \pm 0.25V$ ,  $V_{PP} = 12.5V \pm 0.3V$ ,  $T_a = 25^\circ C \pm 5^\circ C$ , unless otherwise specified)

Item	Symbol	Test Conditions	min	typ	max	Unit
Address setup time	$t_{AS}$		2	—	—	$\mu s$
$\overline{OE}$ setup time	$t_{OES}$		2	—	—	$\mu s$
Data setup time	$t_{DS}$		2	—	—	$\mu s$
Address hold time	$t_{AH}$		0	—	—	$\mu s$
Data hold time	$t_{DH}$		2	—	—	$\mu s$
Data output disable time	$t_{DF}$	See figure 89	—	—	130	ns
$V_{PP}$ setup time	$t_{VPS}$		2	—	—	$\mu s$
Program pulse width	$t_{PW}$		0.95	1.0	1.05	ms
$\overline{CE}$ pulse width during overprogramming	$t_{OPW}$		2.85	—	78.75	ms
$V_{CC}$ setup time	$t_{VCS}$		2	—	—	$\mu s$
Data output delay time	$t_{OE}$		0	—	500	ns

Notes: Input pulse level: 0.8 V to 2.2 V

Input rise/fall times:  $\leq 20ns$

Input timing reference levels: 1.0 V, 2.0 V

Output timing reference levels: 0.8 V, 2.0 V

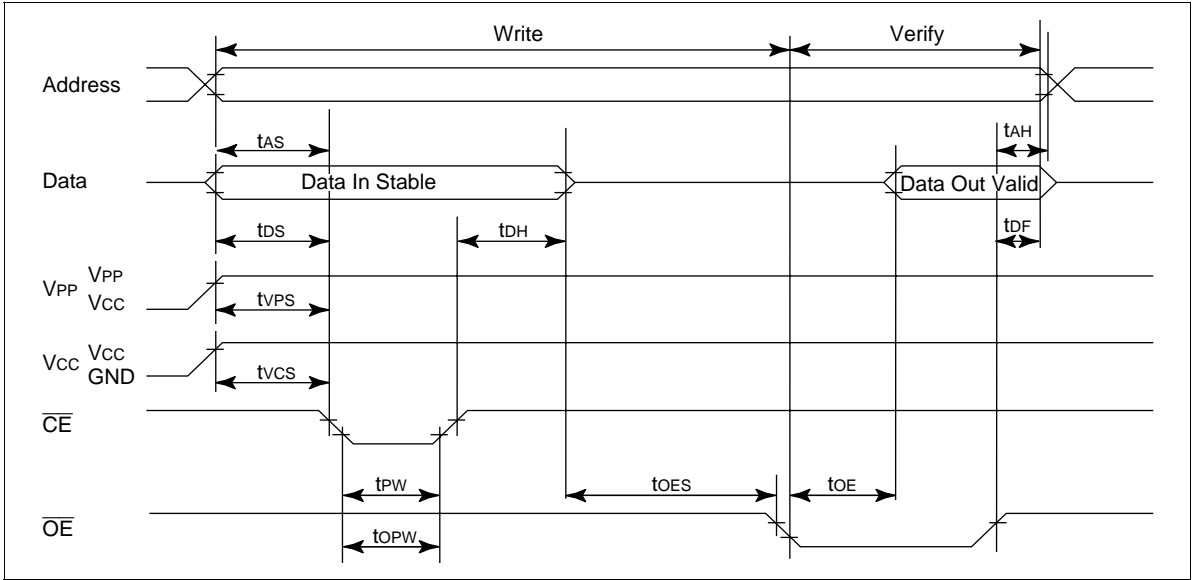


Figure 97 PROM Write/Verify Timing

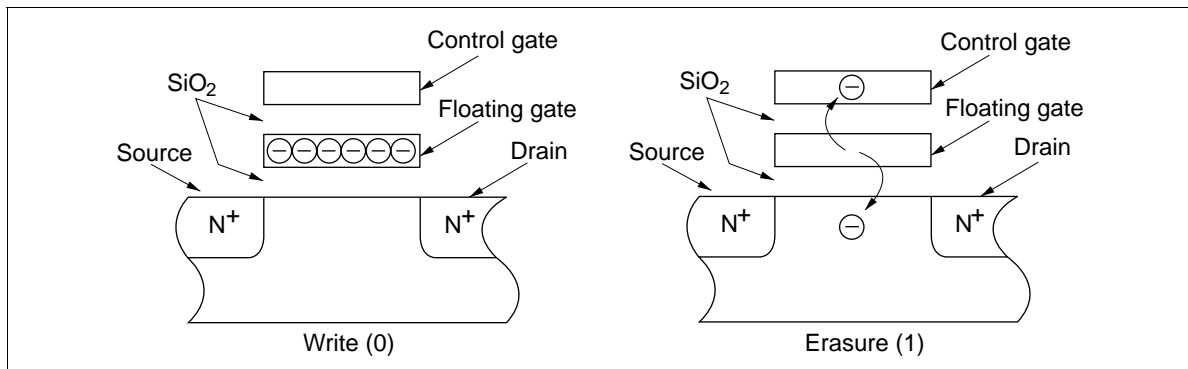
**Notes on PROM Programming**

**Principles of Programming/Erase:** A memory cell in a ZTAT™ microcomputer is the same as an EPROM cell; it is programmed by applying a high voltage between its control gate and drain to inject hot electrons into its floating gate. These electrons are stable, surrounded by an energy barrier formed by an SiO<sub>2</sub> film. The change in threshold voltage of a memory cell with a charged floating gate makes the corresponding bit appear as 0; a cell whose floating gate is not charged appears as a 1 bit (figure 98).

The charge in a memory cell may decrease with time. This decrease is usually due to one of the following causes:

- Ultraviolet light excites electrons, allowing them to escape. This effect is the basis of the erasure principle.
- Heat excites trapped electrons, allowing them to escape.
- High voltages between the control gate and drain may erase electrons.

If the oxide film covering a floating gate is defective, the electron erasure rate will be greater. However, electron erasure does not often occur because defective devices are detected and removed at the testing stage.



**Figure 98 Cross-Sections of a PROM Cell**

**PROM Programming:** PROM memory cells must be programmed under specific voltage and timing conditions. The higher the programming voltage  $V_{PP}$  and the longer the programming pulse  $t_{PW}$  is applied, the more electrons are injected into the floating gates. However, if  $V_{PP}$  exceeds specifications, the pn junctions may be permanently damaged. Pay particular attention to overshooting in the PROM programmer. In addition, note that negative voltage noise will produce a parasitic transistor effect that may reduce breakdown voltages.

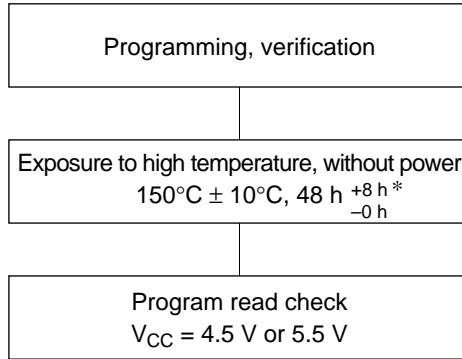
The ZTAT™ microcomputer is electrically connected to the PROM programmer by a socket adapter. Therefore, note the following points:

- Check that the socket adapter is firmly mounted on the PROM programmer.
- Do not touch the socket adapter or the LSI during the programming. Touching them may affect the quality of the contacts, which will cause programming errors.

**PROM Reliability after Programming:** In general, semiconductor devices retain their reliability, provided that some initial defects can be excluded. These initial defects can be detected and rejected by screening. Baking devices under high-temperature conditions is one method of screening that can rapidly eliminate data-hold defects in memory cells. (Refer to the previous Principles of Programming/Erasure section.)

ZTAT™ microcomputer devices are extremely reliable because they have been subjected to such a screening method during the wafer fabrication process, but Hitachi recommends that each device be exposed to 150°C at one atmosphere for at least 48 hours after it is programmed, to ensure its best performance. The recommended screening procedure is shown in figure 99.

Note: If programming errors occur continuously during PROM programming, suspend programming and check for problems in the PROM programmer or socket adapter. If programming verification indicates errors in programming or after high-temperature exposure, please inform Hitachi.



Note: Exposure time is measured from when the temperature in the heater reaches 150°C.

**Figure 99 Recommended Screening Procedure**

## Addressing Modes

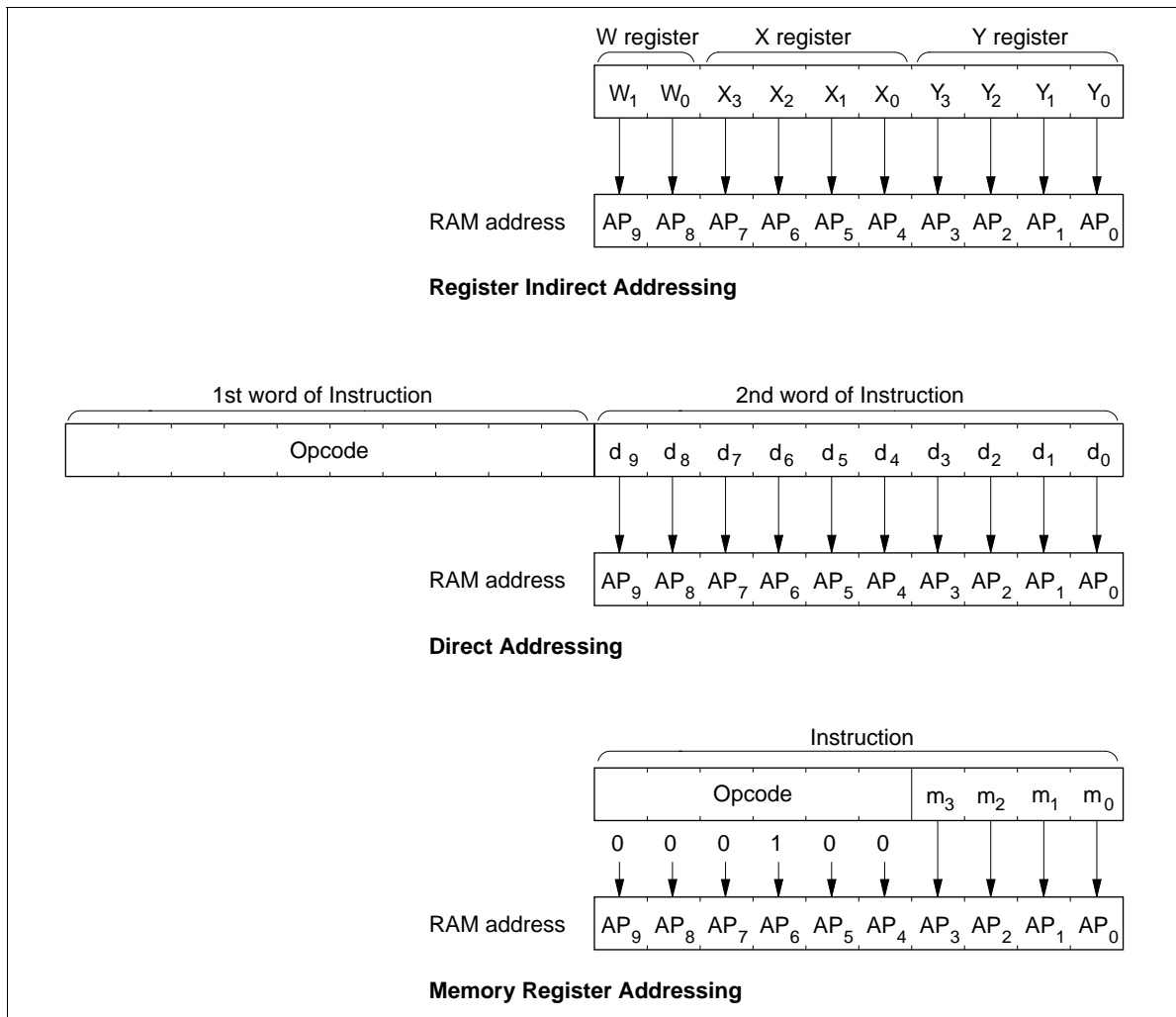
### RAM Addressing Modes

The MCU has three RAM addressing modes, as shown in figure 100 and described below.

**Register Indirect Addressing Mode:** The contents of the W, X, and Y registers (10 bits in total) are used as a RAM address.

**Direct Addressing Mode:** A direct addressing instruction consists of two words. The first word contains the opcode, and the contents of the second word (10 bits) are used as a RAM address.

**Memory Register Addressing Mode:** The memory registers (MR), which are located in 16 addresses from \$040 to \$04F, are accessed with the LAMR and XMRA instructions.



**Figure 100 RAM Addressing Modes**

## ROM Addressing Modes and the P Instruction

The MCU has four ROM addressing modes, as shown in figure 101 and described below.

**Direct Addressing Mode:** A program can branch to any address in the ROM memory space by executing the JMPL, BRL, or CALL instruction. Each of these instructions replaces the 14 program counter bits (PC<sub>13</sub>–PC<sub>0</sub>) with 14-bit immediate data.

**Current Page Addressing Mode:** The MCU has 64 pages of ROM with 256 words per page. A program can branch to any address in the current page by executing the BR instruction. This instruction replaces the eight low-order bits of the program counter (PC<sub>7</sub>–PC<sub>0</sub>) with eight-bit immediate data. If the BR instruction is on a page boundary (address 256n + 255), executing that instruction transfers the PC contents to the next physical page, as shown in figure 103. This means that the execution of the BR instruction on a page boundary will make the program branch to the next page.

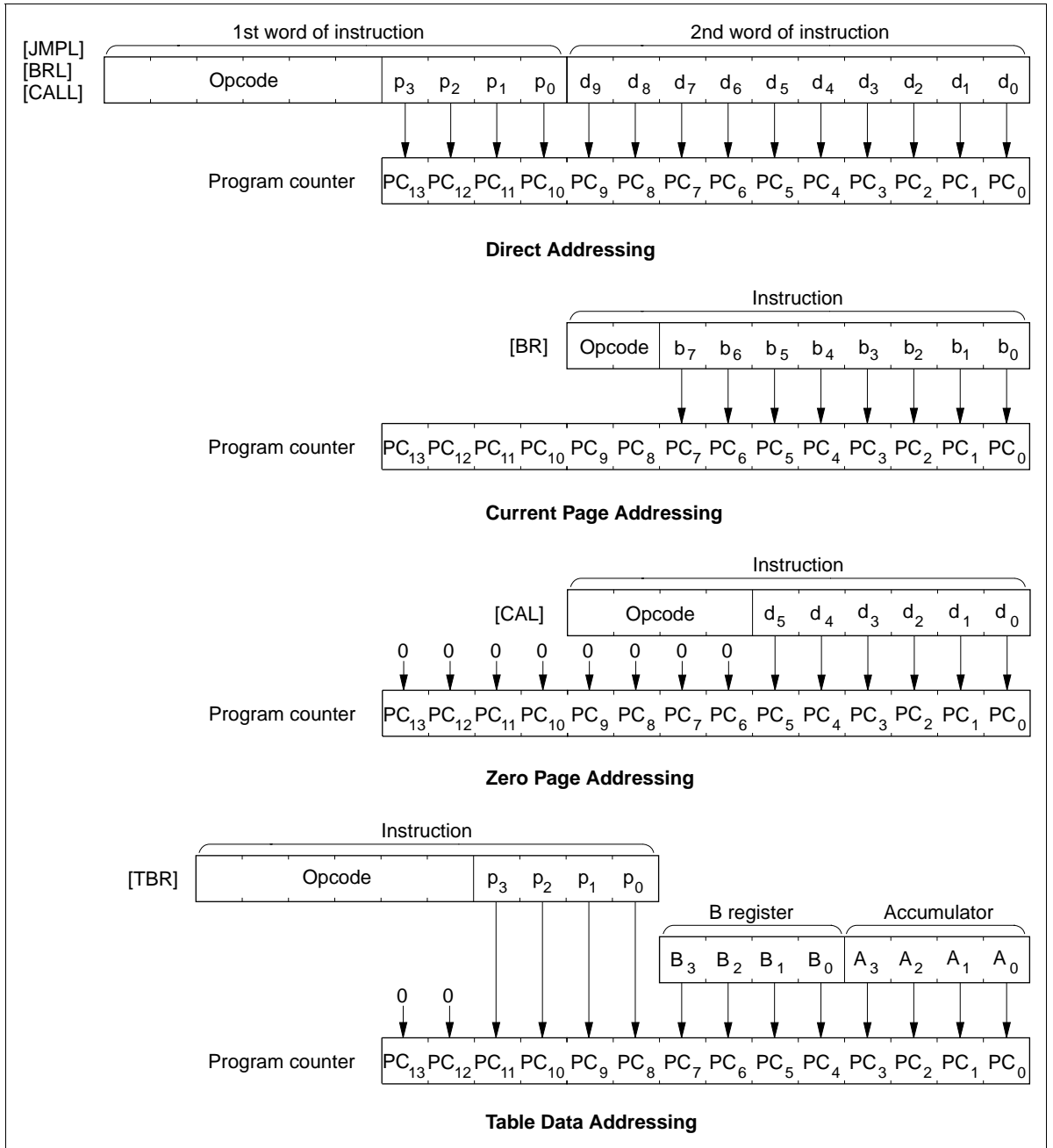
Note that the HMCS400-series cross assembler has an automatic paging feature for ROM pages.

**Zero-Page Addressing Mode:** A program can branch to the zero-page subroutine area located at \$0000–\$003F by executing the CAL instruction. When the CAL instruction is executed, 6 bits of immediate data are placed in the six low-order bits of the program counter (PC<sub>5</sub>–PC<sub>0</sub>), and 0s are placed in the eight high-order bits (PC<sub>13</sub>–PC<sub>6</sub>).

**Table Data Addressing Mode:** A program can branch to an address determined by the contents of four-bit immediate data, the accumulator, and the B register by executing the TBR instruction.

**P Instruction:** ROM data addressed in table data addressing mode can be referenced with the P instruction as shown in figure 102. If bit 8 of the ROM data is 1, eight bits of ROM data are written to the accumulator and the B register. If bit 9 is 1, eight bits of ROM data are written to the R1 and R2 port output registers. If both bits 8 and 9 are 1, ROM data is written to the accumulator and the B register, and also to the R1 and R2 port output registers at the same time.

The P instruction has no effect on the program counter.



**Figure 101 ROM Addressing Modes**

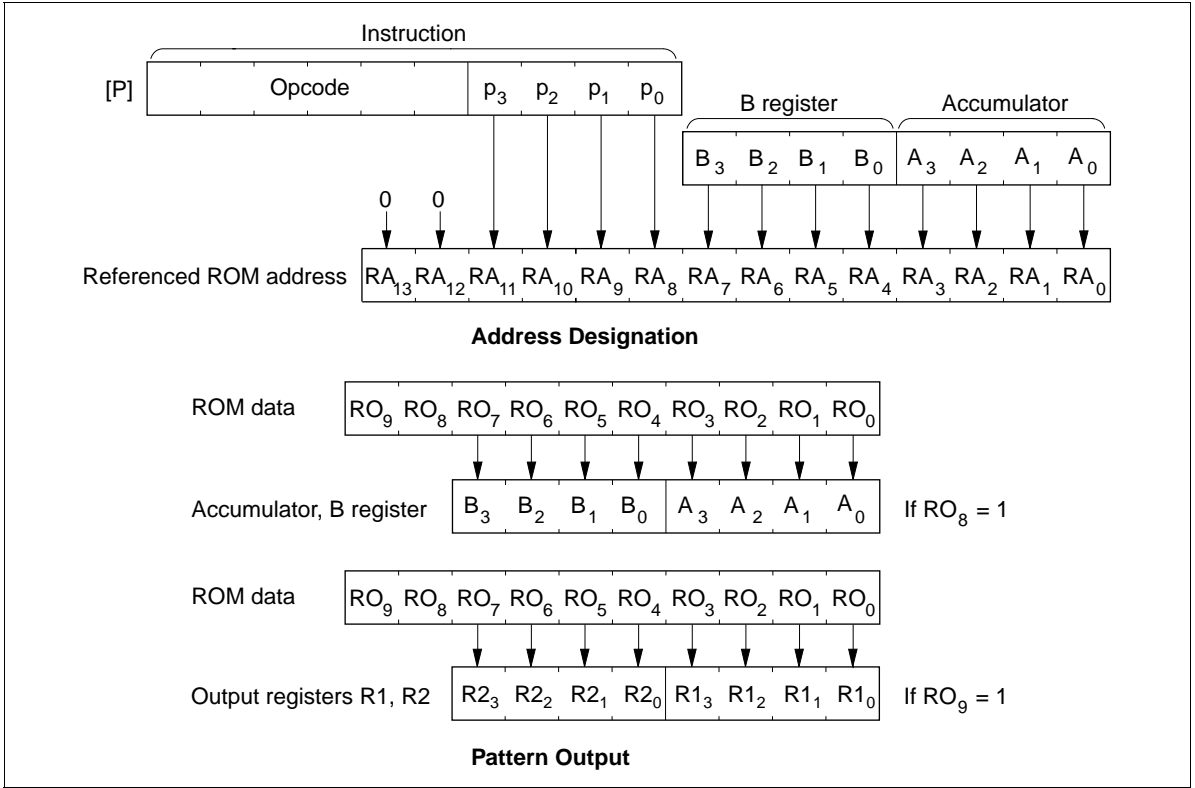


Figure 102 P Instruction

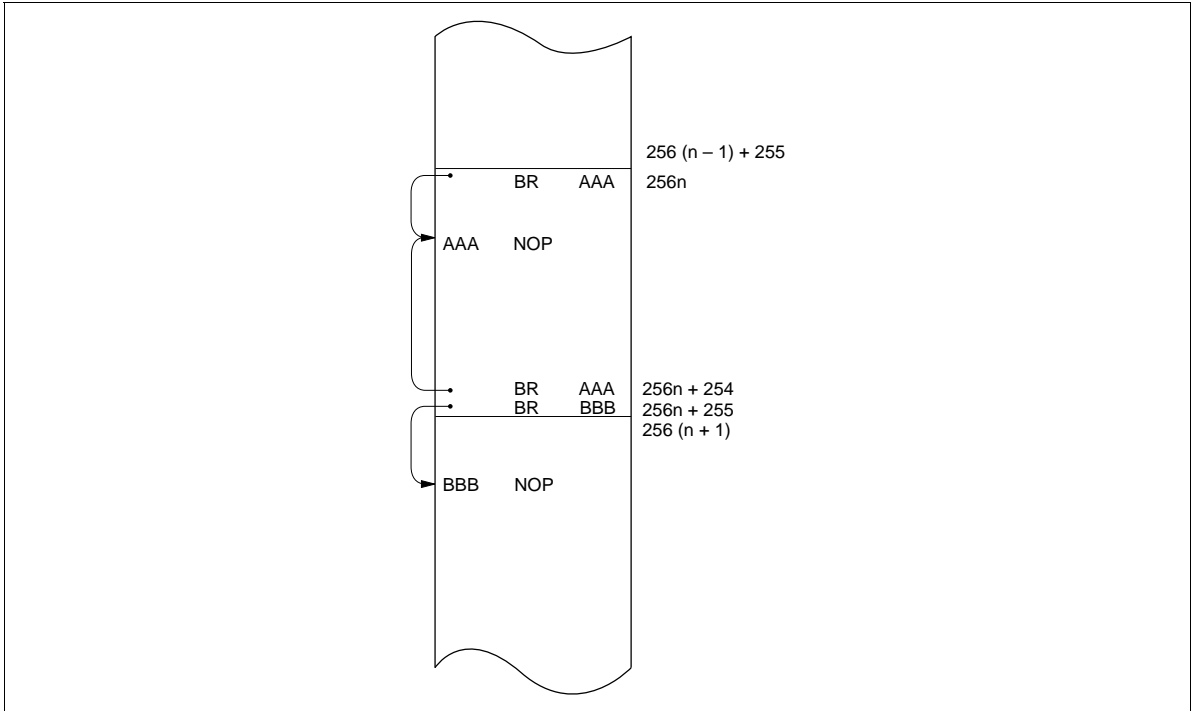


Figure 103 Branching when the Branch Destination is on a Page Boundary

## Instruction Set

The MCU Series has 101 instructions, classified into the following 10 groups:

- Immediate instructions
- Register-to-register instructions
- RAM addressing instructions
- RAM register instructions
- Arithmetic instructions
- Compare instructions
- RAM bit manipulation instructions
- ROM addressing instructions
- Input/output instructions
- Control instructions

The functions of these instructions are listed in tables 31 to 40, and an opcode map is shown in table 41.

**Table 31 Immediate Instructions**

Operation	Mnemonic	Operation Code	Function	Status	Words/ Cycles
Load A from immediate	LAI i	1 0 0 0 1 1 $i_3$ $i_2$ $i_1$ $i_0$	$i \rightarrow A$		1/1
Load B from immediate	LBI i	1 0 0 0 0 0 $i_3$ $i_2$ $i_1$ $i_0$	$i \rightarrow B$		1/1
Load memory from immediate	LMID i,d	0 1 1 0 1 0 $i_3$ $i_2$ $i_1$ $i_0$ $d_9$ $d_8$ $d_7$ $d_6$ $d_5$ $d_4$ $d_3$ $d_2$ $d_1$ $d_0$	$i \rightarrow M$		2/2
Load memory from immediate, increment Y	LMIIY i	1 0 1 0 0 1 $i_3$ $i_2$ $i_1$ $i_0$	$i \rightarrow M, Y + 1 \rightarrow Y$	NZ	1/1

# HD404889/HD404899/HD404878/HD404868 Series

**Table 32 Register-Register Instructions**

Operation	Mnemonic	Operation Code	Function	Status	Words/ Cycles
Load A from B	LAB	0 0 0 1 0 0 1 0 0 0	B → A		1/1
Load B from A	LBA	0 0 1 1 0 0 1 0 0 0	A → B		1/1
Load A from W	LAW	0 1 0 0 0 0 0 0 0 0 0 0 0 0 0 0 0 0 0 0	W → A		2/2*
Load A from Y	LAY	0 0 1 0 1 0 1 1 1 1	Y → A		1/1
Load A from SPX	LASPX	0 0 0 1 1 0 1 0 0 0	SPX → A		1/1
Load A from SPY	LASPY	0 0 0 1 0 1 1 0 0 0	SPY → A		1/1
Load A from MR	LAMR m	1 0 0 1 1 1 m <sub>3</sub> m <sub>2</sub> m <sub>1</sub> m <sub>0</sub>	MR (m) → A		1/1
Exchange MR and A	XMRA m	1 0 1 1 1 1 m <sub>3</sub> m <sub>2</sub> m <sub>1</sub> m <sub>0</sub>	MR (m) ↔ A		1/1

Note: The assembler automatically provides an operand for the second word of the LAW instruction.

**Table 33 RAM Address Instructions**

Operation	Mnemonic	Operation Code	Function	Status	Words/ Cycles
Load W from immediate	LWI i	0 0 1 1 1 1 0 0 i <sub>1</sub> i <sub>0</sub>	i → W		1/1
Load X from immediate	LXI i	1 0 0 0 1 0 i <sub>3</sub> i <sub>2</sub> i <sub>1</sub> i <sub>0</sub>	i → X		1/1
Load Y from immediate	LYI i	1 0 0 0 0 1 i <sub>3</sub> i <sub>2</sub> i <sub>1</sub> i <sub>0</sub>	i → Y		1/1
Load W from A	LWA	0 1 0 0 0 1 0 0 0 0 0 0 0 0 0 0 0 0 0 0	A → W		2/2*
Load X from A	LXA	0 0 1 1 1 0 1 0 0 0	A → X		1/1
Load Y from A	LYA	0 0 1 1 0 1 1 0 0 0	A → Y		1/1
Increment Y	IY	0 0 0 1 0 1 1 1 0 0	Y + 1 → Y	NZ	1/1
Decrement Y	DY	0 0 1 1 0 1 1 1 1 1	Y - 1 → Y	NB	1/1
Add A to Y	AYY	0 0 0 1 0 1 0 1 0 0	Y + A → Y	OVF	1/1
Subtract A from Y	SY Y	0 0 1 1 0 1 0 1 0 0	Y - A → Y	NB	1/1
Exchange X and SPX	XSPX	0 0 0 0 0 0 0 0 0 1	X ↔ SPX		1/1
Exchange Y and SPY	XSPY	0 0 0 0 0 0 0 0 1 0	Y ↔ SPY		1/1
Exchange X and SPX, Y and SPY	XSPXY	0 0 0 0 0 0 0 0 1 1	X ↔ SPX, Y ↔ SPY		1/1

Note: The assembler automatically provides an operand for the second word of the LWA instruction.

**Table 34 RAM Register Instructions**

Operation	Mnemonic	Operation Code	Function	Status	Words/ Cycles
Load A from memory	LAM	0 0 1 0 0 1 0 0 0 0	M → A		1/1
	LAMX	0 0 1 0 0 1 0 0 0 1	M → A X ↔ SPX		
	LAMY	0 0 1 0 0 1 0 0 1 0	M → A Y ↔ SPY		
	LAMXY	0 0 1 0 0 1 0 0 1 1	M → A X ↔ SPX, Y ↔ SPY		
Load A from memory	LAMD d	0 1 1 0 0 1 0 0 0 0 d <sub>9</sub> d <sub>8</sub> d <sub>7</sub> d <sub>6</sub> d <sub>5</sub> d <sub>4</sub> d <sub>3</sub> d <sub>2</sub> d <sub>1</sub> d <sub>0</sub>	M → A		2/2
Load B from memory	LBM	0 0 0 1 0 0 0 0 0 0	M → B		1/1
	LBMX	0 0 0 1 0 0 0 0 0 1	M → B X ↔ SPX		
	LBMY	0 0 0 1 0 0 0 0 1 0	M → B Y ↔ SPY		
	LBMXY	0 0 0 1 0 0 0 0 1 1	M → B X ↔ SPX, Y ↔ SPY		
Load memory from A	LMA	0 0 1 0 0 1 0 1 0 0	A → M		1/1
	LMAX	0 0 1 0 0 1 0 1 0 1	A → M X ↔ SPX		
	LMA Y	0 0 1 0 0 1 0 1 1 0	A → M Y ↔ SPY		
	LMAXY	0 0 1 0 0 1 0 1 1 1	A → M X ↔ SPX, Y ↔ SPY		
Load memory from A	LMAD d	0 1 1 0 0 1 0 1 0 0 d <sub>9</sub> d <sub>8</sub> d <sub>7</sub> d <sub>6</sub> d <sub>5</sub> d <sub>4</sub> d <sub>3</sub> d <sub>2</sub> d <sub>1</sub> d <sub>0</sub>	A → M		2/2
Load memory from A, increment Y	LMAIY	0 0 0 1 0 1 0 0 0 0	A → M, Y + 1 → Y	NZ	1/1
	LMAIYX	0 0 0 1 0 1 0 0 0 1	A → M, Y + 1 → Y X ↔ SPX		
Load memory from A, decrement Y	LMADY	0 0 1 1 0 1 0 0 0 0	A → M, Y - 1 → Y	NB	1/1
	LMADYX	0 0 1 1 0 1 0 0 0 1	A → M, Y - 1 → Y X ↔ SPX		

# HD404889/HD404899/HD404878/HD404868 Series

**Table 34 RAM Register Instructions (cont)**

Operation	Mnemonic	Operation Code	Function	Status	Words/ Cycles
Exchange memory and A	XMA	0 0 1 0 0 0 0 0 0 0	M ↔ A		1/1
	XMAX	0 0 1 0 0 0 0 0 0 1	M ↔ A X ↔ SPX		
	XMAY	0 0 1 0 0 0 0 0 1 0	M ↔ A Y ↔ SPY		
	XMAXY	0 0 1 0 0 0 0 0 1 1	M ↔ A X ↔ SPX, Y ↔ SPY		
Exchange memory and A	XMAD d	0 1 1 0 0 0 0 0 0 0 d <sub>9</sub> d <sub>8</sub> d <sub>7</sub> d <sub>6</sub> d <sub>5</sub> d <sub>4</sub> d <sub>3</sub> d <sub>2</sub> d <sub>1</sub> d <sub>0</sub>	M ↔ A		2/2
Exchange memory and B	XMB	0 0 1 1 0 0 0 0 0 0	M ↔ B		1/1
	XMBX	0 0 1 1 0 0 0 0 0 1	M ↔ B X ↔ SPX		
	XMBY	0 0 1 1 0 0 0 0 1 0	M ↔ B Y ↔ SPY		
	XMBXY	0 0 1 1 0 0 0 0 1 1	M ↔ B X ↔ SPX, Y ↔ SPY		

**Table 35 Arithmetic Instructions**

Operation	Mnemonic	Operation Code	Function	Status	Words/ Cycles
Add immediate to A	AI i	1 0 1 0 0 0 $i_3$ $i_2$ $i_1$ $i_0$	$A + i \rightarrow A$	OVF	1/1
Increment B	IB	0 0 0 1 0 0 1 1 0 0	$B + 1 \rightarrow B$	NZ	1/1
Decrement B	DB	0 0 1 1 0 0 1 1 1 1	$B - 1 \rightarrow B$	NB	1/1
Decimal adjust for addition	DAA	0 0 1 0 1 0 0 1 1 0			1/1
Decimal adjust for subtraction	DAS	0 0 1 0 1 0 1 0 1 0			1/1
Negate A	NEGA	0 0 0 1 1 0 0 0 0 0	$\bar{A} + 1 \rightarrow A$		1/1
Complement B	COMB	0 1 0 1 0 0 0 0 0 0	$\bar{B} \rightarrow B$		1/1
Rotate right A with carry	ROTR	0 0 1 0 1 0 0 0 0 0			1/1
Rotate left A with carry	ROTL	0 0 1 0 1 0 0 0 0 1			1/1
Set carry	SEC	0 0 1 1 1 0 1 1 1 1	$1 \rightarrow CA$		1/1
Reset carry	REC	0 0 1 1 1 0 1 1 0 0	$0 \rightarrow CA$		1/1
Test carry	TC	0 0 0 1 1 0 1 1 1 1		CA	1/1
Add A to memory	AM	0 0 0 0 0 0 1 0 0 0	$M + A \rightarrow A$	OVF	1/1
Add A to memory	AMD d	0 1 0 0 0 0 1 0 0 0 $d_9$ $d_8$ $d_7$ $d_6$ $d_5$ $d_4$ $d_3$ $d_2$ $d_1$ $d_0$	$M + A \rightarrow A$	OVF	2/2
Add A to memory with carry	AMC	0 0 0 0 0 1 1 0 0 0	$M + A + CA \rightarrow A$ $OVF \rightarrow CA$	OVF	1/1
Add A to memory with carry	AMCD d	0 1 0 0 0 1 1 0 0 0 $d_9$ $d_8$ $d_7$ $d_6$ $d_5$ $d_4$ $d_3$ $d_2$ $d_1$ $d_0$	$M + A + CA \rightarrow A$ $OVF \rightarrow CA$	OVF	2/2
Subtract A from memory with carry	SMC	0 0 1 0 0 1 1 0 0 0	$M - A - \bar{CA} \rightarrow A$ $NB \rightarrow CA$	NB	1/1
Subtract A from memory with carry	SMCD d	0 1 1 0 0 1 1 0 0 0 $d_9$ $d_8$ $d_7$ $d_6$ $d_5$ $d_4$ $d_3$ $d_2$ $d_1$ $d_0$	$M - A - \bar{CA} \rightarrow A$ $NB \rightarrow CA$	NB	2/2
OR A and B	OR	0 1 0 1 0 0 0 1 0 0	$A \cup B \rightarrow A$		1/1
AND memory with A	ANM	0 0 1 0 0 1 1 1 0 0	$A \cap M \rightarrow A$	NZ	1/1
AND memory with A	ANMD d	0 1 1 0 0 1 1 1 0 0 $d_9$ $d_8$ $d_7$ $d_6$ $d_5$ $d_4$ $d_3$ $d_2$ $d_1$ $d_0$	$A \cap M \rightarrow A$	NZ	2/2
OR memory with A	ORM	0 0 0 0 0 0 1 1 0 0	$A \cup M \rightarrow A$	NZ	1/1
OR memory with A	ORMD d	0 1 0 0 0 0 1 1 0 0 $d_9$ $d_8$ $d_7$ $d_6$ $d_5$ $d_4$ $d_3$ $d_2$ $d_1$ $d_0$	$A \cup M \rightarrow A$	NZ	2/2
EOR memory with A	EORM	0 0 0 0 0 1 1 1 0 0	$A \oplus M \rightarrow A$	NZ	1/1
EOR memory with A	EORMD d	0 1 0 0 0 1 1 1 0 0 $d_9$ $d_8$ $d_7$ $d_6$ $d_5$ $d_4$ $d_3$ $d_2$ $d_1$ $d_0$	$A \oplus M \rightarrow A$	NZ	2/2

# HD404889/HD404899/HD404878/HD404868 Series

**Table 36 Compare Instructions**

Operation	Mnemonic	Operation Code	Function	Status	Words/ Cycles
Immediate not equal to memory	INEM i	0 0 0 0 1 0 $i_3$ $i_2$ $i_1$ $i_0$	$i \neq M$	NZ	1/1
Immediate not equal to memory	INEMD i,d	0 1 0 0 1 0 $i_3$ $i_2$ $i_1$ $i_0$ $d_9$ $d_8$ $d_7$ $d_6$ $d_5$ $d_4$ $d_3$ $d_2$ $d_1$ $d_0$	$i \neq M$	NZ	2/2
A not equal to memory	ANEM	0 0 0 0 0 0 0 1 0 0	$A \neq M$	NZ	1/1
A not equal to memory	ANEMD d	0 1 0 0 0 0 0 1 0 0 $d_9$ $d_8$ $d_7$ $d_6$ $d_5$ $d_4$ $d_3$ $d_2$ $d_1$ $d_0$	$A \neq M$	NZ	2/2
B not equal to memory	BNEM	0 0 0 1 0 0 0 1 0 0	$B \neq M$	NZ	1/1
Y not equal to immediate	YNEI i	0 0 0 1 1 1 $i_3$ $i_2$ $i_1$ $i_0$	$Y \neq i$	NZ	1/1
Immediate less than or equal to memory	ILEM i	0 0 0 0 1 1 $i_3$ $i_2$ $i_1$ $i_0$	$i \leq M$	NB	1/1
Immediate less than or equal to memory	ILEMD i,d	0 1 0 0 1 1 $i_3$ $i_2$ $i_1$ $i_0$ $d_9$ $d_8$ $d_7$ $d_6$ $d_5$ $d_4$ $d_3$ $d_2$ $d_1$ $d_0$	$i \leq M$	NB	2/2
A less than or equal to memory	ALEM	0 0 0 0 0 1 0 1 0 0	$A \leq M$	NB	1/1
A less than or equal to memory	ALEMD d	0 1 0 0 0 1 0 1 0 0 $d_9$ $d_8$ $d_7$ $d_6$ $d_5$ $d_4$ $d_3$ $d_2$ $d_1$ $d_0$	$A \leq M$	NB	2/2
B less than or equal to memory	BLEM	0 0 1 1 0 0 0 1 0 0	$B \leq M$	NB	1/1
A less than or equal to immediate	ALEI i	1 0 1 0 1 1 $i_3$ $i_2$ $i_1$ $i_0$	$A \leq i$	NB	1/1

**Table 37 RAM Bit Manipulation Instructions**

Operation	Mnemonic	Operation Code	Function	Status	Words/ Cycles
Set memory bit	SEM n	0 0 1 0 0 0 0 1 $n_1$ $n_0$	$i \rightarrow M(n)$		1/1
Set memory bit	SEMD n,d	0 1 1 0 0 0 0 1 $n_1$ $n_0$ $d_9$ $d_8$ $d_7$ $d_6$ $d_5$ $d_4$ $d_3$ $d_2$ $d_1$ $d_0$	$i \rightarrow M(n)$		2/2
Reset memory bit	REM n	0 0 1 0 0 0 1 0 $n_1$ $n_0$	$0 \rightarrow M(n)$		1/1
Reset memory bit	REMD n,d	0 1 1 0 0 0 1 0 $n_1$ $n_0$ $d_9$ $d_8$ $d_7$ $d_6$ $d_5$ $d_4$ $d_3$ $d_2$ $d_1$ $d_0$	$0 \rightarrow M(n)$		2/2
Test memory bit	TM n	0 0 1 0 0 0 1 1 $n_1$ $n_0$		M(n)	1/1
Test memory bit	TM n,d	0 1 1 0 0 0 1 1 $n_1$ $n_0$ $d_9$ $d_8$ $d_7$ $d_6$ $d_5$ $d_4$ $d_3$ $d_2$ $d_1$ $d_0$		M(n)	2/2

**Table 38 ROM Address Instructions**

Operation	Mnemonic	Operation Code	Function	Status	Words/ Cycles
Branch on status 1	BR b	1 1 b <sub>7</sub> b <sub>6</sub> b <sub>5</sub> b <sub>4</sub> b <sub>3</sub> b <sub>2</sub> b <sub>1</sub> b <sub>0</sub>		1	1/1
Long branch on status 1	BRL u	0 1 0 1 1 1 p <sub>3</sub> p <sub>2</sub> p <sub>1</sub> p <sub>0</sub> d <sub>9</sub> d <sub>8</sub> d <sub>7</sub> d <sub>6</sub> d <sub>5</sub> d <sub>4</sub> d <sub>3</sub> d <sub>2</sub> d <sub>1</sub> d <sub>0</sub>		1	2/2
Long jump unconditionally	JMPL u	0 1 0 1 0 1 p <sub>3</sub> p <sub>2</sub> p <sub>1</sub> p <sub>0</sub> d <sub>9</sub> d <sub>8</sub> d <sub>7</sub> d <sub>6</sub> d <sub>5</sub> d <sub>4</sub> d <sub>3</sub> d <sub>2</sub> d <sub>1</sub> d <sub>0</sub>			2/2
Subroutine jump on status 1	CAL a	0 1 1 1 a <sub>5</sub> a <sub>4</sub> a <sub>3</sub> a <sub>2</sub> a <sub>1</sub> a <sub>0</sub>		1	1/2
Long subroutine jump on status 1	CALL u	0 1 0 1 1 0 p <sub>3</sub> p <sub>2</sub> p <sub>1</sub> p <sub>0</sub> d <sub>9</sub> d <sub>8</sub> d <sub>7</sub> d <sub>6</sub> d <sub>5</sub> d <sub>4</sub> d <sub>3</sub> d <sub>2</sub> d <sub>1</sub> d <sub>0</sub>		1	2/2
Table branch	TBR p	0 0 1 0 1 1 p <sub>3</sub> p <sub>2</sub> p <sub>1</sub> p <sub>0</sub>		1	1/1
Return from subroutine	RTN	0 0 0 0 0 1 0 0 0 0			1/3
Return from interrupt	RTNI	0 0 0 0 0 1 0 0 0 1	1 → IE, carry restored	ST	1/1

**Table 39 Input/Output Instructions**

Operation	Mnemonic	Operation Code	Function	Status	Words/ Cycles
Set discrete I/O latch	SED	0 0 1 1 1 0 0 1 0 0	1 → D (Y)		1/1
Set discrete I/O latch direct	SEDD m	1 0 1 1 1 0 m <sub>3</sub> m <sub>2</sub> m <sub>1</sub> m <sub>0</sub>	1 → D (m)		1/1
Reset discrete I/O latch	RED	0 0 0 1 1 0 0 1 0 0	0 → D (Y)		1/1
Reset discrete I/O latch direct	REDD m	1 0 0 1 1 0 m <sub>3</sub> m <sub>2</sub> m <sub>1</sub> m <sub>0</sub>	0 → D (m)		1/1
Test discrete I/O latch	TD	0 0 1 1 1 0 0 0 0 0		D (Y)	1/1
Test discrete I/O latch direct	TDD m	1 0 1 0 1 0 m <sub>3</sub> m <sub>2</sub> m <sub>1</sub> m <sub>0</sub>		D (m)	1/1
Load A from R-port register	LAR m	1 0 0 1 0 1 m <sub>3</sub> m <sub>2</sub> m <sub>1</sub> m <sub>0</sub>	R (m) → A		1/1
Load B from R-port register	LBR m	1 0 0 1 0 0 m <sub>3</sub> m <sub>2</sub> m <sub>1</sub> m <sub>0</sub>	R (m) → B		1/1
Load R-port register from A	LRA m	1 0 1 1 0 1 m <sub>3</sub> m <sub>2</sub> m <sub>1</sub> m <sub>0</sub>	A → R (m)		1/1
Load R-port register from B	LRB m	1 0 1 1 0 0 m <sub>3</sub> m <sub>2</sub> m <sub>1</sub> m <sub>0</sub>	B → R (m)		1/1
Pattern generation	P p	0 1 1 0 1 1 p <sub>3</sub> p <sub>2</sub> p <sub>1</sub> p <sub>0</sub>			1/2

# HD404889/HD404899/HD404878/HD404868 Series

**Table 40** Control Instructions

Operation	Mnemonic	Operation Code	Function	Status	Words/ Cycles
No operation	NOP	0 0 0 0 0 0 0 0 0 0			1/1
Start serial	STS	0 1 0 1 0 0 1 0 0 0			1/1
Standby mode/watch mode*	SBY	0 1 0 1 0 0 1 1 0 0			1/1
Stop mode/watch mode	STOP	0 1 0 1 0 0 1 1 0 1			1/1

Note: Only after a transition from subactive mode.

**Table 41 Opcode Map**

R9 H	R8 L	0																		
		0	1	2	3	4	5	6	7	8	9	A	B	C	D	E	F			
0	0	NOP	XSPX	XSPY	XSPXY	ANEM				AM				ORM						
	1	RTN	RTNI			ALEM				AMC				EORM						
	2	INEM i(4)																		
	3	ILEM i(4)																		
	4	LBM(XY)				BNEM				LAB				IB						
	5	LMAIY(X)					AYY			LASPY				IY						
	6	NEGA				RED				LASPX								TC		
	7	YNEI i(4)																		
	8	XMA(XY)					SEM n(2)					REM n(2)					TM n(2)			
	9	LAM(XY)					LMA(XY)				SMC				ANM					
	A	ROTR	ROTL						DAA					DAS				LAY		
	B	TBR p(4)																		
	C	XMB(XY)				BLEM				LBA								DB		
	D	LMADY(X)					SYI			LYA								DY		
	E	TD				SED				LXA					REC			SEC		
	F	LWI i(2)																		
1	0	LBI i(4)																		
	1	LYI i(4)																		
	2	LXI i(4)																		
	3	LAI i(4)																		
	4	LBR m(4)																		
	5	LAR m(4)																		
	6	REDD m(4)																		
	7	LAMR m(4)																		
	8	AI i(4)																		
	9	LMIIY i(4)																		
	A	TDD m(4)																		
	B	ALEI i(4)																		
	C	LRB m(4)																		
	D	LRA m(4)																		
	E	SEDD m(4)																		
	F	XMRA m(4)																		

1-word/2-cycle instruction    
  1-word/3-cycle instruction    
  RAM direct address instruction (2-word/2-cycle)    
  2-word/2-cycle instruction

**Table 41 Opcode Map (cont)**

R9	R8	1																
		0	1	2	3	4	5	6	7	8	9	A	B	C	D	E	F	
0	0	LAW				ANEMD				AMD				ORMD				
	1	LWA				ALEMED				AMCD				EORMD				
	2	INEMD i(4)																
	3	ILEMD i(4)																
	4	COMB				OR				STS				SBY	STOP			
	5	JMPL p(4)																
	6	CALL p(4)																
	7	BRL p(4)																
	8	XMAD					SEMD n(2)				REMD n(2)				TMD n(2)			
	9	LAMD				LMAD				SMCD				ANMD				
	A	LMID i(4)																
	B	P p(4)																
	C																	
	D																	
	E	CAL a(6)																
	F																	
1	0																	
	1																	
	2																	
	3																	
	4																	
	5																	
	6																	
	7																	
	8	BR b(8)																
	9																	
	A																	
	B																	
	C																	
	D																	
	E																	
	F																	

1-word/2-cycle instruction    
  1-word/3-cycle instruction    
  RAM direct address instruction (2-word/2-cycle)    
  2-word/2-cycle instruction

## Absolute Maximum Ratings

Item	Symbol	Value	Unit	Notes
Power supply voltage	$V_{CC}$	-0.3 to +7.0	V	
Programming voltage	$V_{PP}$	-0.3 to +14.0	V	1
Pin voltage	$V_T$	-0.3 to $V_{CC}+0.3$	V	
Allowable input current (total)	$\sum I_o$	100	mA	2
Allowable output current (total)	$-\sum I_o$	50	mA	3
Allowable input current (per pin)	$I_o$	4	mA	4,5
		30	mA	4,6
Allowable output current (per pin)	$-I_o$	4	mA	7,8
		20	mA	7,9
Operating temperature	$T_{opr}$	-20 to +75	°C	10
Storage temperature	$T_{stg}$	-55 to +125	°C	11

Notes: Permanent damage may occur if these maximum ratings are exceeded. Normal operation must be under the conditions stated in the electrical characteristics tables. If these conditions are exceeded, the LSI may malfunction or its reliability may be affected.

1. Applies to the HD4074889, HD4074899, and HD4074869 TEST ( $V_{PP}$ ) pin.
2. The allowable input current (total) is the sum of all currents flowing from I/O pins to ground at the same time.
3. The allowable output current (total) is the sum of all currents flowing from  $V_{CC}$  to I/O pins.
4. The allowable input current (per pin) is the maximum current allowed to flow from any one I/O pin to ground.
5. Applies to pins  $D_0$  to  $D_3$  and R0 to R8.
6. Applies to pins  $D_4$  to  $D_{11}$ .
7. The allowable output current (per pin) is the maximum current allowed to flow from  $V_{CC}$  to any one I/O pin.
8. Applies to pins  $D_4$  to  $D_{11}$  and R0 to R8.
9. Applies to pins  $D_0$  to  $D_3$ .
10. The operating temperature indicates the temperature range in which power can be supplied to the LSI (voltage  $V_{CC}$  shown in the electrical characteristics tables can be applied).
11. In the case of chips, the storage specification differs from that of the package products. Please consult your Hitachi sales representative for details.

# HD404889/HD404899/HD404878/HD404868 Series

## Electrical Characteristics

DC Characteristics (HD404888, HD4048812, HD404889, HD404898, HD4048912, HD404899, HD404874, HD404878, HD404864, HD404868:  $V_{CC}=1.8V$  to  $5.5V$ ,  $GND=0V$ ,  $T_a=-20^{\circ}C$  to  $+75^{\circ}C$ ; HCD404889, HCD404899, HCD404878:  $V_{CC}=1.8V$  to  $5.5V$ ,  $GND=0V$ ,  $T_a=+75^{\circ}C$ ; HD4074889, HD4074899, HD4074869:  $V_{CC}=2.0V$  to  $5.5V$ ,  $GND=0V$ ,  $T_a=-20^{\circ}C$  to  $+75^{\circ}C$ , unless otherwise specified)

Item	Symbol	Pins	min.	typ.	max.	Unit	Test conditions	Notes
Input high voltage	$V_{IH}$	$\overline{RESET}, \overline{SCK}, SI, INT_0, INT_1, WU_0$ to $WU_3, EVNB, EVND$	$0.90V_{CC}$	—	$V_{CC}+0.3$	V		
		$OSC_1$	$V_{CC}-0.3$	—	$V_{CC}+0.3$	V	External clock operation	
Input low voltage	$V_{IL}$	$\overline{RESET}, \overline{SCK}, SI, INT_0, INT_1, WU_0$ to $WU_3, EVNB, EVND$	-0.3	—	$0.10V_{CC}$	V		
		$OSC_1$	-0.3	—	0.3	V	External clock operation	
Output high voltage	$V_{OH}$	$\overline{SCK}, SO, BUZZ, TOB, TOC$	$V_{CC}-0.5$	—	—	V	$-I_{OH}=0.3mA$	
Output low voltage	$V_{OL}$	$\overline{SCK}, SO, BUZZ, TOB, TOC$	—	—	0.4	V	$I_{OL}=0.4mA$	
I/O leakage current	$ I_{IL} $	$\overline{RESET}, \overline{SCK}, SI, INT_0, INT_1, WU_0$ to $WU_3, EVNB, EVND, OSC_1, TOB, TOC, SO, BUZZ$	—	—	1	$\mu A$	$V_{in}=0V$ to $V_{CC}$	1
Active mode current dissipation	$I_{CC1}$	$V_{CC}$	—	3.0	5.0	mA	$V_{CC}=5V, f_{osc}=4MHz$	2
	$I_{CC2}$	$V_{CC}$	—	0.4	1.0	mA	$V_{CC}=3V, f_{osc}=800kHz$	2
Standby mode current dissipation	$I_{SBY1}$	$V_{CC}$	—	1.0	2.0	mA	$V_{CC}=5V, f_{osc}=4MHz, LCD$ on	3
	$I_{SBY2}$	$V_{CC}$	—	0.3	0.6	mA	$V_{CC}=3V, f_{osc}=800kHz$ LCD on	3
Subactive mode current dissipation	$I_{SUB}$	$V_{CC}$ (HD404888, HD4048812, HD404889, HCD404889, HD404898, HD4048912, HD404899, HCD404899, HD404874, HD404878, HCD404878, HD404864, HD404868)	—	35	60	$\mu A$	$V_{CC}=3V, LCD$ on, 32 kHz oscillator used	4,5
		$V_{CC}$ (HD4074889, HD4074899, HD4074869)	—	70	120	$\mu A$		4,5

# HD404889/HD404899/HD404878/HD404868 Series

Item	Symbol	Pins	min.	typ.	max.	Unit	Test Conditions	Notes
Watch mode current dissipation	$I_{WTC1}$	$V_{CC}$	—	15	30	$\mu\text{A}$	$V_{CC} = 3\text{ V}$ , LCD on, 32 kHz oscillator used	4,5
	$I_{WTC2}$	$V_{CC}$	—	5	8	$\mu\text{A}$	$V_{CC} = 3\text{ V}$ , LCD off, 32 kHz oscillator used	5
Stop mode current dissipation	$I_{STOP}$	$V_{CC}$	—	—	5	$\mu\text{A}$	$V_{CC} = 3\text{ V}$ , no 32 kHz oscillator	5
Stop mode retention voltage	$V_{STOP}$	$V_{CC}$	1.5	—	—	V	no 32 kHz oscillator	6

- Notes:
1. Excludes output buffer current.
  2. Power supply current when the MCU is in the reset state and there are no I/O currents.

Test Conditions	MCU State	<ul style="list-style-type: none"> <li>• Reset state</li> </ul>
	Pin States	<ul style="list-style-type: none"> <li>• <math>\overline{\text{RESET}}</math>, TEST: At ground</li> </ul>

3. Power supply current when the on-chip timers are operating and there are no I/O currents.

Test Conditions	MCU State	<ul style="list-style-type: none"> <li>• I/O: Same as reset state</li> <li>• Standby mode</li> <li>• <math>f_{cyc} = f_{osc}/4</math></li> </ul>
	Pin States	<ul style="list-style-type: none"> <li>• <math>\overline{\text{RESET}}</math>: At <math>V_{CC}</math></li> <li>• TEST: At ground</li> <li>• <math>D_0</math> to <math>D_{11}</math>, <math>R_0</math> to <math>R_8</math>: At <math>V_{CC}</math></li> </ul>

4. Applies when the LCD power supply dividing resistor is connected.
5. Power supply current when there are no I/O currents.

Test Conditions	Pin States	<ul style="list-style-type: none"> <li>• <math>\overline{\text{RESET}}</math>: At <math>V_{CC}</math></li> <li>• TEST: At ground</li> <li>• <math>D_0</math> to <math>D_{11}</math>, <math>R_0</math> to <math>R_8</math>: At <math>V_{CC}</math></li> </ul>
-----------------	------------	--

6. Voltage needed to retain RAM data.

# HD404889/HD404899/HD404878/HD404868 Series

I/O Characteristics for Standard Pins (HD404888, HD4048812, HD404889, HD404898, HD4048912, HD404899, HD404874, HD404878, HD404864, HD404868:  $V_{CC}=1.8V$  to  $5.5V$ ,  $GND=0V$ ,  $T_a=-20^{\circ}C$  to  $+75^{\circ}C$ ; HCD404889, HCD404899, HCD404878:  $V_{CC}=1.8V$  to  $5.5V$ ,  $GND=0V$ ,  $T_a=+75^{\circ}C$ ; HD4074889, HD4074899, HD4074869:  $V_{CC}=2.0V$  to  $5.5V$ ,  $GND=0V$ ,  $T_a=-20^{\circ}C$  to  $+75^{\circ}C$ , unless otherwise specified)

Item	Symbol	Pins	min.	typ.	max.	Unit	Test conditions	Notes
Input high voltage	$V_{IH}$	R0 to R8	$0.7V_{CC}$	—	$V_{CC}+0.3$	V		1
		R0 to R7						2
Input low voltage	$V_{IL}$	R0 to R8	-0.3	—	$0.3V_{CC}$	V		1
		R0 to R7						2
Output high voltage	$V_{OH}$	R0 to R8	$V_{CC}-0.5$	—	—	V	$-I_{OH}=0.3mA$	1
		R0 to R7						2
Output low voltage	$V_{OL}$	R0 to R8	—	—	0.4	V	$I_{OL}=0.4mA$	1
		R0 to R7						2
I/O leakage current	$ I_{IL} $	R0 to R8	—	—	1	$\mu A$	$V_{IN}=0V$ to $V_{CC}$	1, 3
		R0 to R7						2, 3
MOS pull-up current	$-I_{PU}$	R0 to R8	10	50	150	$\mu A$	$V_{CC}=3V$ , $V_{IN}=0V$	1
		R0 to R7						2

- Notes: 1. Applies to the HD404889, HD404899, and HD404878 Series.  
 2. Applies to the HD404868 Series.  
 3. Excludes the current flowing in the output buffer.

## HD404889/HD404899/HD404878/HD404868 Series

**I/O Characteristics for High-Current Pins (HD404888, HD4048812, HD404889, HD404898, HD4048912, HD404899, HD404874, HD404878, HD404864, HD404868:  $V_{CC}=1.8V$  to  $5.5V$ ,  $GND=0V$ ,  $T_a=-20^{\circ}C$  to  $+75^{\circ}C$ ; HCD404889, HCD404899, HCD404878:  $V_{CC}=1.8V$  to  $5.5V$ ,  $GND=0V$ ,  $T_a=+75^{\circ}C$ ; HD4074889, HD4074899, HD4074869:  $V_{CC}=2.0V$  to  $5.5V$ ,  $GND=0V$ ,  $T_a=-20^{\circ}C$  to  $+75^{\circ}C$ , unless otherwise specified)**

Item	Symbol	Pins	min.	typ.	max.	Unit	Test conditions	Notes
Input high voltage	$V_{IH}$	$D_0$ to $D_{11}$	$0.7V_{CC}$	—	$V_{CC}+0.3$	V		1
		$D_0$ to $D_9$						2
Input low voltage	$V_{IL}$	$D_0$ to $D_{11}$	-0.3	—	$0.3V_{CC}$	V		1
		$D_0$ to $D_9$						2
Output high voltage	$V_{OH}$	$D_4$ to $D_{11}$	$V_{CC}-0.5$	—	—	V	$-I_{OH}=0.3mA$	1
		$D_4$ to $D_9$						2
		$D_0$ to $D_3$	$V_{CC}-2.0$	—	—	V	$-I_{OH}=10mA$ , $V_{CC}=4.5$ to $5.5V$	
Output low voltage	$V_{OL}$	$D_0$ to $D_3$	—	—	0.4	V	$I_{OL}=0.4mA$	
		$D_4$ to $D_{11}$	—	—	2.0	V	$I_{OL}=15mA$	1
		$D_4$ to $D_9$					$V_{CC}=4.5V$ to $5.5V$	2
I/O leakage current	$ I_{IL} $	$D_0$ to $D_{11}$	—	—	1	$\mu A$	$V_{IN}=0V$ to $V_{CC}$	1, 3
		$D_0$ to $D_9$						2, 3
MOS pull-up current	$-I_{PU}$	$D_0$ to $D_{11}$	10	50	150	$\mu A$	$V_{CC}=3V$ , $V_{IN}=0V$	1
		$D_0$ to $D_9$						2

Notes: 1. Applies to the HD404889, HD404899, and HD404878 Series.

2. Applies to the HD404868 Series.

3. Excludes the current flowing in the output buffer.

## HD404889/HD404899/HD404878/HD404868 Series

**LCD Circuit Characteristics (HD404888, HD4048812, HD404889, HD404898, HD4048912, HD404899, HD404874, HD404878, HD404864, HD404868:  $V_{CC}=1.8V$  to  $5.5V$ ,  $GND=0V$ ,  $T_a=-20^{\circ}C$  to  $+75^{\circ}C$ ; HCD404889, HCD404899, HCD404878:  $V_{CC}=1.8V$  to  $5.5V$ ,  $GND=0V$ ,  $T_a=+75^{\circ}C$ ; HD4074889, HD4074899, HD4074869:  $V_{CC}=2.0V$  to  $5.5V$ ,  $GND=0V$ ,  $T_a=-20^{\circ}C$  to  $+75^{\circ}C$ , unless otherwise specified)**

Item	Symbol	Pins	min.	typ.	max.	Unit	Test conditions	Notes
Segment driver voltage drop	$V_{DS}$	SEG1 to SEG32	—	—	0.6	V	$I_D=3\mu A$ $V_1=2.7$ to $5.5V$	1, 2
		SEG1 to SEG24						1, 3
Common driver voltage drop	$V_{DC}$	COM1 to COM4	—	—	0.3	V	$I_D=3\mu A$ $V_1=2.7$ to $5.5V$	1
LCD power supply dividing resistance	$R_W$		50	300	900	k $\Omega$	$V_1-GND$	
LCD voltage	$V_{LCD}$	$V_1$	2.2	—	$V_{CC}$	V		4, 5

- Notes:
1. The voltage drop from power supply pins  $V_1$ ,  $V_2$ ,  $V_3$ , and GND to each segment pin or each common pin.
  2. Applies to the HD404889, HD404899, and HD404878 Series.
  3. Applies to the HD404868 Series.
  4. In the HD404889, HD404899, and HD404878 Series, when  $V_{LCD}$  is supplied by the internal power supply,  $V_0$  and  $V_1$  should be shorted. When  $V_{LCD}$  is supplied by an external power supply, the relationship  $V_{CC} \geq V_{LCD} \geq 2.2V$  should be maintained. In this case, the  $V_0$  pin should be fixed at  $V_{CC}$ .
  5. In the HD404868 Series, when  $V_{LCD}$  is supplied by an external power supply, the relationship  $V_{CC} \geq V_{LCD} \geq 2.2V$  should be maintained.

## HD404889/HD404899/HD404878/HD404868 Series

**A/D Converter Characteristics (HD404888, HD4048812, HD404889:  $V_{CC}=1.8V$  to  $5.5V$ ,  $GND=0V$ ,  $T_a=-20^{\circ}C$  to  $+75^{\circ}C$ ; HCD404889:  $V_{CC}=1.8V$  to  $5.5V$ ,  $GND=0V$ ,  $T_a=+75^{\circ}C$ ; HD4074889:  $V_{CC}=2.0V$  to  $5.5V$ ,  $GND=0V$ ,  $T_a=-20^{\circ}C$  to  $+75^{\circ}C$ , unless otherwise specified)**

Item	Symbol	Pins	min.	typ.	max.	Unit	Test conditions	Notes
Analog power supply voltage	$AV_{CC}$	$AV_{CC}$	$V_{CC}-0.3$	$V_{CC}$	$V_{CC}+0.3$	V		1
Analog input voltage	$AV_{in}$	$AN_0$ to $AN_5$	$AV_{SS}$	—	$AV_{CC}$	V		
$AV_{CC}-AV_{SS}$ current	$I_{AD}$		—	—	500	$\mu A$	$V_{CC}=AV_{CC}=5.0V$	
Analog input capacitance	$CA_{in}$	$AN_0$ to $AN_5$	—	15	—	pF		
Resolution			—	8	—	bit		
Number of inputs			0	—	6	channel		
Absolute accuracy			—	—	$\pm 2.0$	LSB	$V_{CC}=AV_{CC}=2.7V$ to $5.5V$	
			—	—	$\pm 3.0$	LSB	$V_{CC}=AV_{CC}=1.8V$ to $2.7V$	2
Conversion time			65	—	125	$t_{cyc}$		
Input impedance		$AN_0$ to $AN_5$	1	—	—	$M\Omega$		

- Notes: 1. Connect to the  $V_{CC}$  pin when the A/D converter is not used. The  $AV_{CC}$  setting ranges are  $1.8V \leq AV_{CC} \leq 5.5V$  (HD404888, HD4048812, HD404889, HCD404889) and  $2.0V \leq AV_{CC} \leq 5.5V$  (HD4074889)
2. The conversion time is  $125t_{cyc}$ .

## HD404889/HD404899/HD404878/HD404868 Series

(HD404898, HD4048912, HD404899:  $V_{CC}=1.8V$  to  $5.5V$ ,  $GND=0V$ ,  $T_a=-20^{\circ}C$  to  $+75^{\circ}C$ ;

HCD404899:  $V_{CC}=1.8V$  to  $5.5V$ ,  $GND=0V$ ,  $T_a=+75^{\circ}C$ ;

HD4074899:  $V_{CC}=2.0V$  to  $5.5V$ ,  $GND=0V$ ,  $T_a=-20^{\circ}C$  to  $+75^{\circ}C$ , unless otherwise specified)

Item	Symbol	Pins	min.	typ.	max.	Unit	Test conditions	Notes
Analog power supply voltage	$AV_{CC}$	$AV_{CC}$	$V_{CC}-0.3$	$V_{CC}$	$V_{CC}+0.3$	V		1
Analog input voltage	$AV_{in}$	$AN_0$ to $AN_5$	$AV_{SS}$	—	$AV_{CC}$	V		
$AV_{CC}-AV_{SS}$ current	$I_{AD}$		—	—	500	$\mu A$	$V_{CC}=AV_{CC}=5.0V$	
Analog input capacitance	$CA_{in}$	$AN_0$ to $AN_5$	—	15	—	pF		
Resolution			—	10	—	bit		
Number of inputs			0	—	6	channel		
Conversion time			125	—	—	$t_{cyc}$	$V_{CC} = AV_{CC} = 1.8 V$ to less than $2.0 V$	2
			65	—	125	$t_{cyc}$	$V_{CC}=AV_{CC}=2.0 V$ to $5.5V$	
Absolute accuracy			—	—	$\pm 4.0$	LSB		
Input impedance		$AN_0$ to $AN_5$	1	—	—	$M\Omega$		

Notes: 1. Connect to the  $V_{CC}$  pin when the A/D converter is not used. The  $AV_{CC}$  setting ranges are  $1.8 V \leq AV_{CC} \leq 5.5V$  (HD404898, HD4048912, HD404899, HCD404899) and  $2.0V \leq AV_{CC} \leq 5.5V$  (HD4074899)

2. Applies to HD404898, HD4048912, HD404899, and HCD404899.

(HD404864, HD404868:  $V_{CC}=1.8V$  to  $5.5V$ ,  $GND=0V$ ,  $T_a=-20^{\circ}C$  to  $+75^{\circ}C$ ; HD4074869:  $V_{CC}=2.0V$  to  $5.5V$ ,  $GND=0V$ ,  $T_a=-20^{\circ}C$  to  $+75^{\circ}C$ )

Item	Symbol	Pins	min.	typ.	max.	Unit	Test conditions	Notes
Analog input voltage	$AV_{in}$	$AN_0$ to $AN_3$	GND	—	$V_{CC}$	V		
Analog input capacitance	$CA_{in}$	$AN_0$ to $AN_3$	—	15	—	pF		
Resolution			—	10	—	bit		
Number of inputs			0	—	4	channel		
Absolute accuracy			—	—	$\pm 4.0$	LSB		
Conversion time			125	—	—	$t_{cyc}$	$V_{CC} = 1.8 V$ to less than $2.0 V$	1
			65	—	125	$t_{cyc}$	$V_{CC}= 2.0 V$ to $5.5V$	
Input impedance		$AN_0$ to $AN_3$	1	—	—	$M\Omega$		

Note: 1. Applies to HD404864 and HD404868.

# HD404889/HD404899/HD404878/HD404868 Series

**AC Characteristics (HD404888, HD4048812, HD404889, HD404898, HD4048912, HD404899, HD404874, HD404878, HD404864, HD404868:  $V_{CC}=1.8V$  to  $5.5V$ ,  $GND=0V$ ,  $T_a=-20^{\circ}C$  to  $+75^{\circ}C$ ; HCD404889, HCD404899, HCD404878:  $V_{CC}=1.8V$  to  $5.5V$ ,  $GND=0V$ ,  $T_a=+75^{\circ}C$ ; HD4074889, HD4074899, HD4074869:  $V_{CC}=2.0V$  to  $5.5V$ ,  $GND=0V$ ,  $T_a=-20^{\circ}C$  to  $+75^{\circ}C$ , unless otherwise specified)**

Item	Symbol	Pins	min.	typ.	max.	Unit	Test conditions	Notes
Clock oscillation frequency	$f_{OSC}$	OSC <sub>1</sub> , OSC <sub>2</sub>	0.4	—	4.5	MHz	Division by 4	1
		X1,X2	—	32.768	—	kHz		
Instruction cycle time	$t_{cyc}$		0.89	—	10	$\mu s$	Division by 4	
			—	244.14	—	$\mu s$	32 kHz oscillator used, division by 8	
			—	122.07	—	$\mu s$	32 kHz oscillator used, division by 4	
Oscillation settling time(external clock and ceramic oscillator)	$t_{RC}$	OSC <sub>1</sub> , OSC <sub>2</sub>	—	—	7.5	ms		2
Oscillation settling time(crystal oscillator)	$t_{RC}$	OSC <sub>1</sub> , OSC <sub>2</sub>	—	—	30	ms	$V_{CC}=2.0$ to $5.5V$	2
		X1,X2	—	—	2	s	$T_a=-10$ to $+60^{\circ}C$	2
External clock high-level width	$t_{CPH}$	OSC <sub>1</sub>	105	—	—	ns	$f_{OSC}=4MHz$	3
External clock low-level width	$t_{CPL}$	OSC <sub>1</sub>	105	—	—	ns	$f_{OSC}=4MHz$	3
External clock rise time	$t_{CPr}$	OSC <sub>1</sub>	—	—	20	ns	$f_{OSC}=4MHz$	3
External clock fall time	$t_{CPf}$	OSC <sub>1</sub>	—	—	20	ns	$f_{OSC}=4MHz$	3
$\overline{INT}_0$ to INT <sub>1</sub> , EVNB, EVND, $\overline{WU}_0$ to $\overline{WU}_3$ high-level width	$t_{IH}$	$\overline{INT}_0$ to INT <sub>1</sub> , EVNB, EVND, $\overline{WU}_0$ to $\overline{WU}_3$	2	—	—	$t_{cyc}/t_{subcyc}$		4
$\overline{INT}_0$ to INT <sub>1</sub> , EVNB, EVND, $\overline{WU}_0$ to $\overline{WU}_3$ low-level width	$t_{IL}$	$\overline{INT}_0$ to INT <sub>1</sub> , EVNB, EVND, $\overline{WU}_0$ to $\overline{WU}_3$	2	—	—	$t_{cyc}/t_{subcyc}$		4
$\overline{RESET}$ low-level width	$t_{RSTL}$	$\overline{RESET}$	2	—	—	$t_{cyc}$		5
$\overline{RESET}$ rise time	$t_{RSTr}$	$\overline{RESET}$	—	—	20	ms		5
Input capacitance	$C_{in}$	All input pins except TEST	—	—	15	pF	$f=1MHz, V_{in}=0V$	
		TEST (HD404888, HD4048812, HD404889, HCD404889, HD404899, HD404898, HD4048912, HCD404899, HD404874, HD404878, HCD404878, HD404864, HD404868)	—	—	15	pF		
		TEST (HD4074889, HD4074899, HD4074869)	—	—	40	pF		

# HD404889/HD404899/HD404878/HD404868 Series

- Notes: 1. When the subsystem oscillator (32.768 kHz crystal oscillation) is used, use within the range  $0.4\text{ MHz} \leq f_{\text{OSC}} \leq 1.0\text{ MHz}$  or  $1.6\text{ MHz} \leq f_{\text{OSC}} \leq 4.5\text{ MHz}$ . The SSR1 bit of the system clock select register (SSR) should be set to 0 and 1, respectively.
2. The oscillation settling time is defined as follows:
- (1) The time required for the oscillation to settle after  $V_{\text{CC}}$  has reached min. at power-on.
  - (2) The time required for the oscillation to settle after  $\overline{\text{RESET}}$  input has gone low when stop mode is cleared.
- To ensure enough time for the oscillation to settle at power-on hold the  $\overline{\text{RESET}}$  input low for at least time  $t_{\text{RC}}$ . The oscillation settling time will depend on the circuit constants and stray capacitance. The resonator should be determined in consultation with the resonator manufacturer. With regard to the system clock (OSC<sub>1</sub>, OSC<sub>2</sub>), bits MIS1 and MIS0 in the miscellaneous register (MIS) should be set according to the oscillation settling time of the resonator used.
3. See figure 104.
  4. See figure 105.
  5. See figure 106.

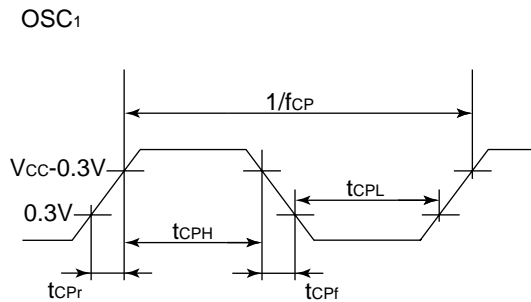
**Serial Interface Timing Characteristics (HD404888, HD4048812, HD404889, HD404898, HD4048912, HD404899, HD404874, HD404878, HD404864, HD404868:  $V_{\text{CC}}=1.8\text{V}$  to  $5.5\text{V}$ ,  $\text{GND}=0\text{V}$ ,  $T_{\text{a}}=-20^{\circ}\text{C}$  to  $+75^{\circ}\text{C}$ ;; HCD404889, HCD404899, HCD404878:  $V_{\text{CC}}=1.8\text{V}$  to  $5.5\text{V}$ ,  $\text{GND}=0\text{V}$ ,  $T_{\text{a}}=+75^{\circ}\text{C}$ ; HD4074889, HD4074899, HD4074869:  $V_{\text{CC}}=2.0\text{V}$  to  $5.5\text{V}$ ,  $\text{GND}=0\text{V}$ ,  $T_{\text{a}}=-20^{\circ}\text{C}$  to  $+75^{\circ}\text{C}$ , unless otherwise specified)**

Item	Symbol	Pins	min.	typ.	max.	Unit	Test conditions	Notes
Serial clock cycle time	$t_{\text{Syc}}$	$\overline{\text{SCK}}$	1	—	—	$t_{\text{cyc}}$	See load in figure 108	1
Serial clock high-level width	$t_{\text{SCKH}}$	$\overline{\text{SCK}}$	0.4	—	—	$t_{\text{Syc}}$	See load in figure 108	1
Serial clock low-level width	$t_{\text{SCKL}}$	$\overline{\text{SCK}}$	0.4	—	—	$t_{\text{Syc}}$	See load in figure 108	1
Serial clock rise time	$t_{\text{SC Kr}}$	$\overline{\text{SCK}}$	—	—	100	ns	See load in figure 108	1
Serial clock fall time	$t_{\text{SCKf}}$	$\overline{\text{SCK}}$	—	—	100	ns	See load in figure 108	1
Serial output data delay time	$t_{\text{DSO}}$	SO	—	—	300	ns	See load in figure 108	1
Serial input data setup time	$t_{\text{SSI}}$	SI	200	—	—	ns		1
Serial input data hold time	$t_{\text{HSI}}$	SI	200	—	—	ns		1

## During Serial Clock Input

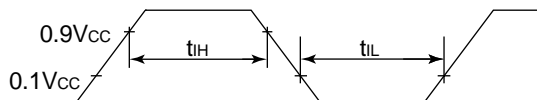
Item	Symbol	Pins	min.	typ.	max.	Unit	Test conditions	Notes
Serial clock cycle time	$t_{S_{cyc}}$	$\overline{SCK}$	1	—	—	$t_{cyc}$		1
Serial clock high-level width	$t_{SCKH}$	$\overline{SCK}$	0.4	—	—	$t_{S_{cyc}}$		1
Serial clock low-level width	$t_{SCKL}$	$\overline{SCK}$	0.4	—	—	$t_{S_{cyc}}$		1
Serial clock rise time	$t_{SC_{Kr}}$	$\overline{SCK}$	—	—	100	ns		1
Serial clock fall time	$t_{SCKf}$	$\overline{SCK}$	—	—	100	ns		1
Serial output data delay time	$t_{DSO}$	SO	—	—	300	ns	See load in figure 108	1
Serial input data setup time	$t_{SSI}$	SI	200	—	—	ns		1
Serial input data hold time	$t_{HSI}$	SI	200	—	—	ns		1

Note: 1. See figure 107.



**Figure 104 External Clock Input Waveform**

$\overline{INT}_0$ ,  $INT_1$ ,  $EVNB$ ,  $EVND$ ,  $\overline{WU}_0$  to  $\overline{WU}_3$



**Figure 105 Interrupt Timing**

RESET

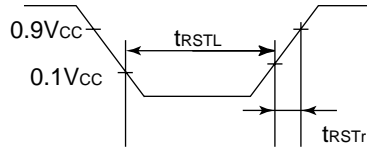
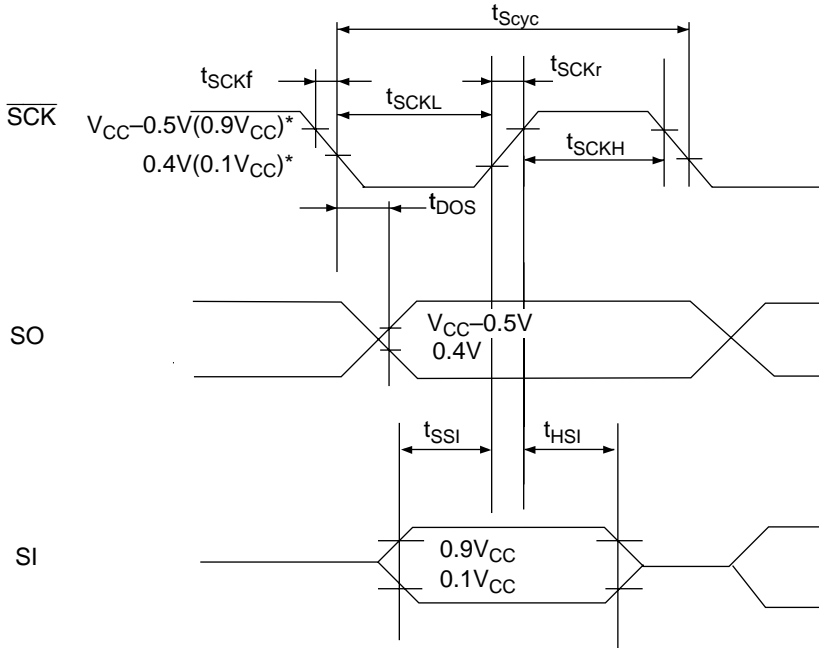


Figure 106 Reset Timing



Note :  $V_{CC}-0.5V$  and  $0.4V$  are the voltages during serial clock output.  
 $0.9 V_{CC}$  and  $0.1 V_{CC}$  are the voltages during serial clock input.

Figure 107 Serial Interface Timing

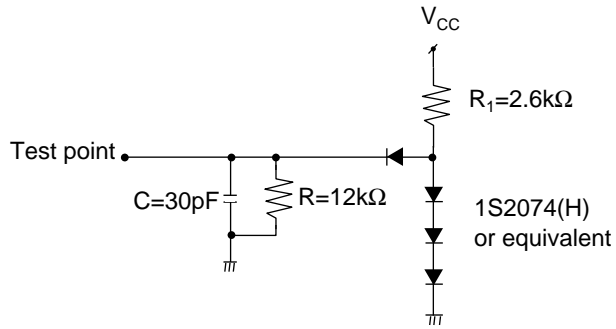
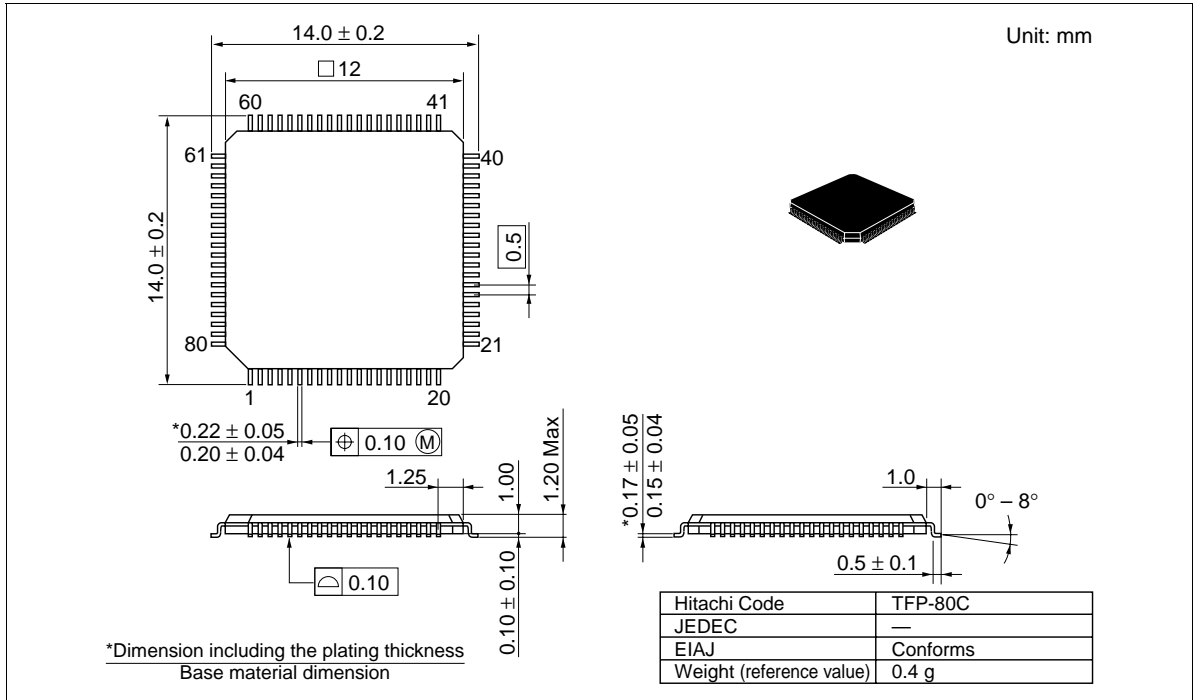
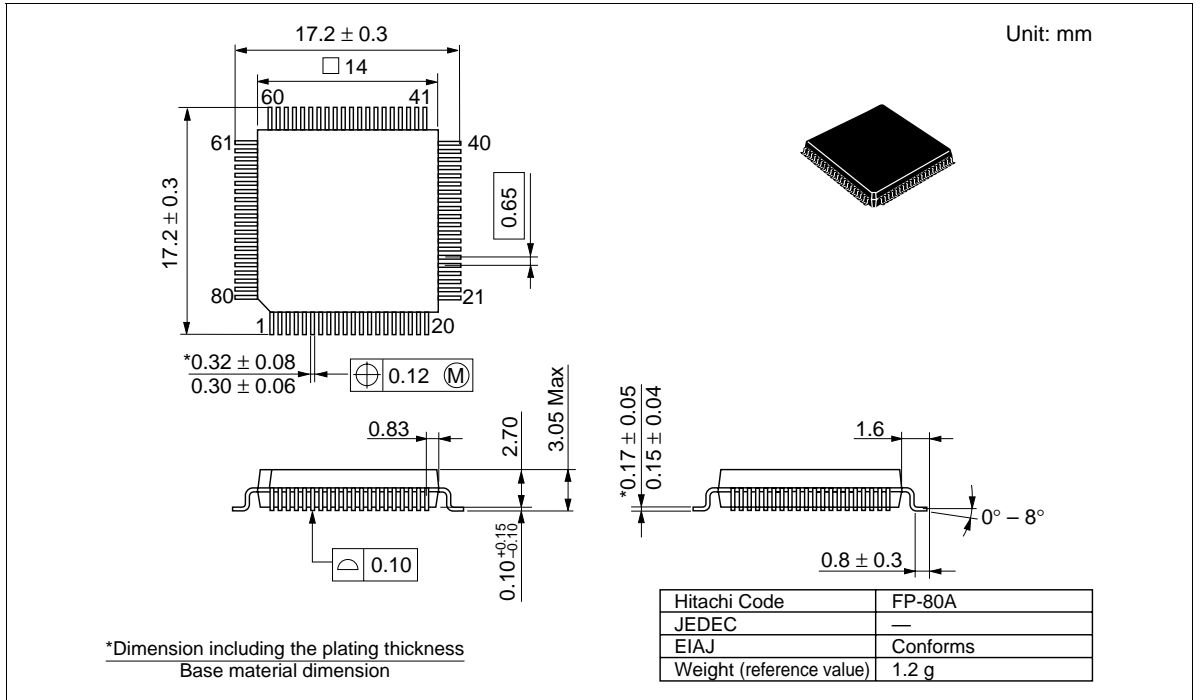


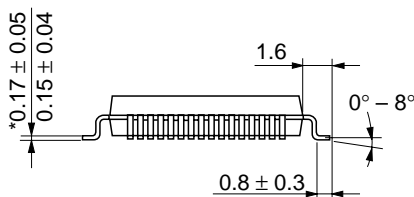
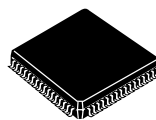
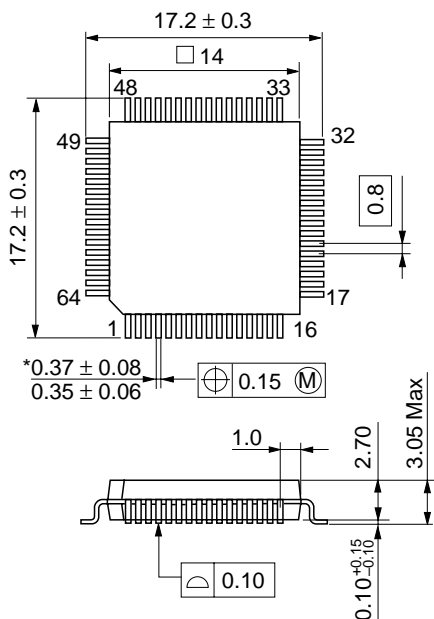
Figure 108 Timing Load Circuit

## Package Dimensions



# HD404889/HD404899/HD404878/HD404868 Series

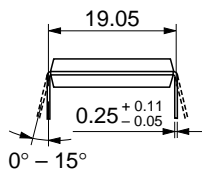
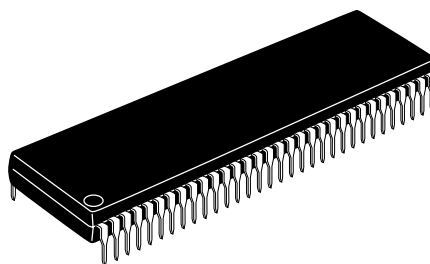
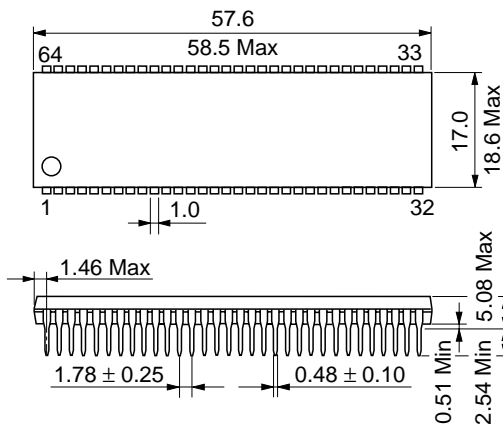
Unit: mm



\*Dimension including the plating thickness  
Base material dimension

Hitachi Code	FP-64A
JEDEC	—
EIAJ	Conforms
Weight (reference value)	1.2 g

Unit: mm



Hitachi Code	DP-64S
JEDEC	—
EIAJ	Conforms
Weight (reference value)	8.8 g

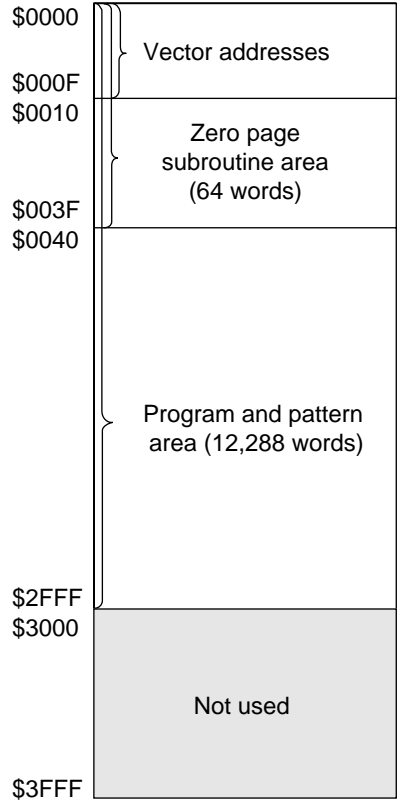
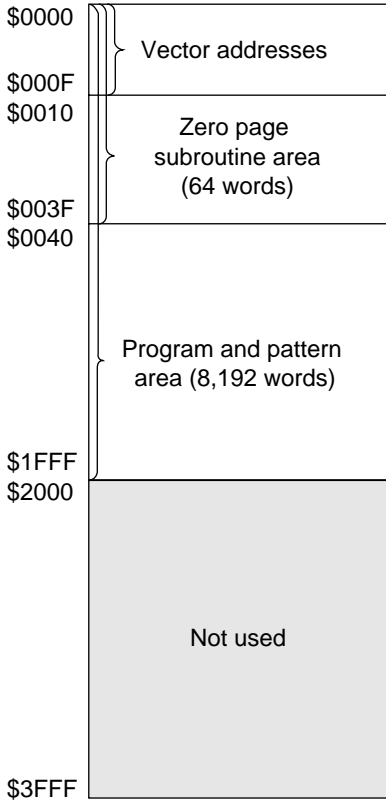
## Note on ROM Ordering

Please note the following when ordering HD404888, HD4048812, HD404898 or HD4048912 ROM.

When ordering ROM, please fill the "Not used" areas below with all-1 data, to give the same amount of data as for the 16-kwords version (HD404889, HD404899). The program that converts ROM data to mask drawing data is the same as that used for the 16-kwords version, and therefore the same amount of data is necessary. This applies both to orders using EPROM and orders using data transmission.

8-kword ROM  
version: HD404888, HD404898  
Write all-1 data to addresses  
\$2000 to \$3FFF.

12-kword ROM version:  
HD4048812, HD4048912  
Write all-1 data to addresses  
\$3000 to \$3FFF.

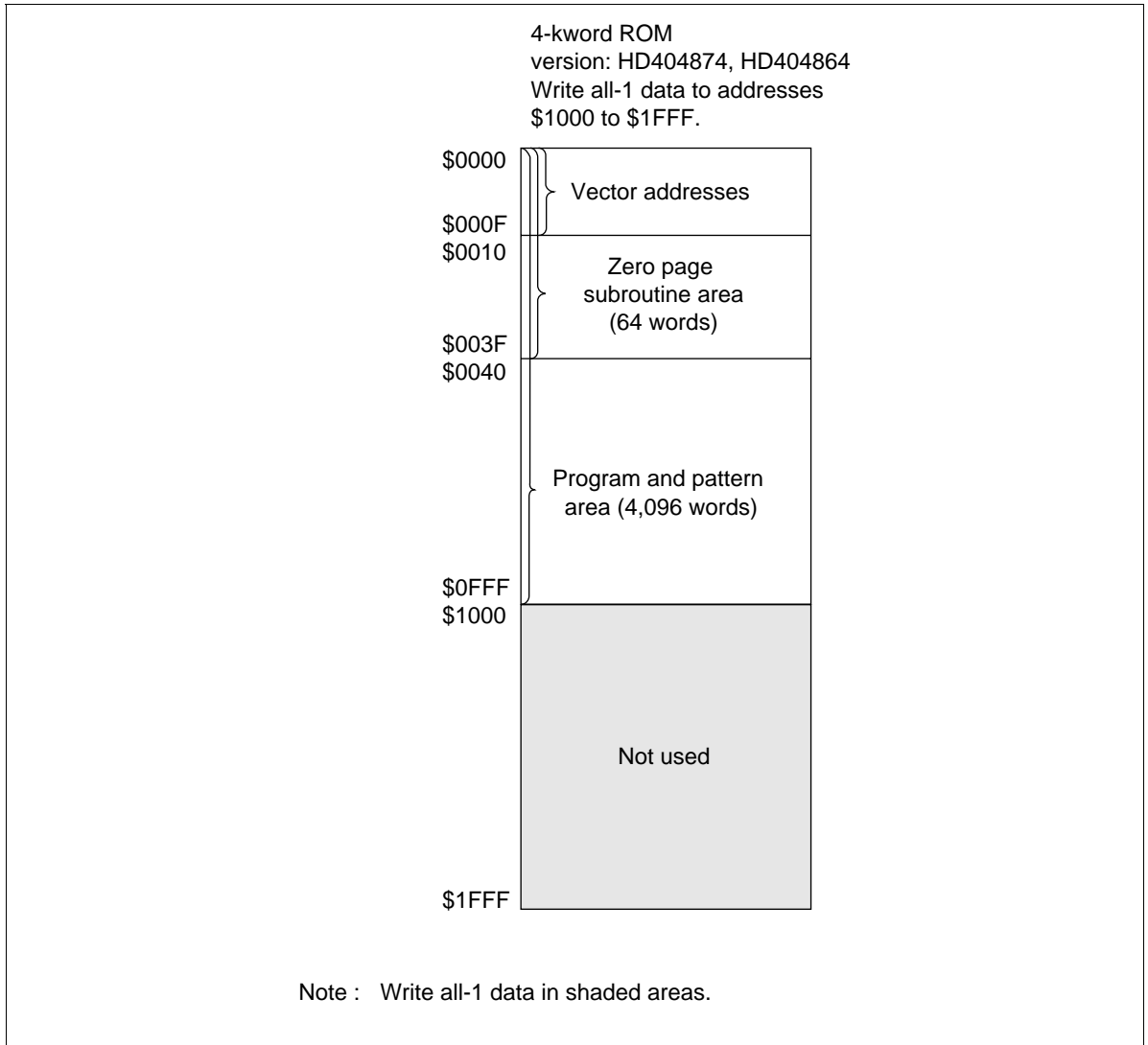


Note : Write all-1 data in shaded areas.

## Note on ROM Ordering

Please note the following when ordering HD404874 or HD404864 ROM.

When ordering ROM, please fill the "Not used" areas below with all-1 data, to give the same amount of data as for the 8-kwords version (HD404878, HD404868). The program that converts ROM data to mask drawing data is the same as that used for the 8-kwords version, and therefore the same amount of data is necessary. This applies both to orders using EPROM and orders using data transmission.



---

# HD404889/HD404899/HD404878/HD404868 Series

---

## Option List HD404888, HD4048812, HD404889, HCD404889

Please check off the appropriate applications and enter the necessary information.

Date of order	Year	Month	Day
Customer			
Department			
Name			
ROM code name			
LSI number (Hitachi entry)			

---

### 1. ROM Size

<input type="checkbox"/> HD404888	8 kwords
<input type="checkbox"/> HD4048812	12 kwords
<input type="checkbox"/> HD404889	16 kwords
<input type="checkbox"/> HCD404889	16 kwords

---

### 2. Function Options

- \*  32 kHz CPU operation, realtime clock time base
  - \*  No 32 kHz CPU operation, realtime clock time base
  - No 32 kHz CPU operation, no realtime clock time base
- 

Note: When an asterisked item is selected, "crystal resonator" is necessary for subsystem oscillator (X1 X2).

### 3. ROM Code Data Organization

For a microcomputer with EPROM mounted (including a ZTAT™ microcomputer), specify the combined upper/lower type.

- Combined lower/upper type
    - Both the lower 5 data bits (L) and the upper 5 data bits (U) are written to a single EPROM in the order LULULU...
  - Separate lower/upper type
    - The lower 5 data bits (L) and upper 5 data bits (U) are written to separate EPROMs respectively.
- 

### 4. System Oscillator (OSC1-OSC2)

- Ceramic oscillator                      f =     MHz
  - Crystal oscillator                        f =     MHz
  - External clock                            f =     MHz
-

---

## HD404889/HD404899/HD404878/HD404868 Series

---

### 5. Subsystem Oscillator (X1 X2)

---

- |  |                |
|--|----------------|
| <input type="checkbox"/> Not used          | —              |
| <input type="checkbox"/> Crystal resonator | f = 32.768 kHz |
- 

### 6. Stop Mode

---

- |  |
|--|
| <input type="checkbox"/> Yes (used)    |
| <input type="checkbox"/> No (not used) |
- 

### 7. Package

---

- |                                  |
|----------------------------------|
| <input type="checkbox"/> FP-80A  |
| <input type="checkbox"/> TFP-80C |
| <input type="checkbox"/> Chip    |
- 

Note: The specifications of shipped chips differ from those of the package product. Please contact our sales staff for details.

---

# HD404889/HD404899/HD404878/HD404868 Series

---

## Option List HD404898, HD4048912, HD404899, HCD404899

Please check off the appropriate applications and enter the necessary information.

Date of order	Year	Month	Day
Customer			
Department			
Name			
ROM code name			
LSI number (Hitachi entry)			

### 1. ROM Size

<input type="checkbox"/> HD404898	8 kwords
<input type="checkbox"/> HD4048912	12 kwords
<input type="checkbox"/> HD404899	16 kwords
<input type="checkbox"/> HCD404899	16 kwords

### 2. Function Options

- \*  32 kHz CPU operation, realtime clock time base
- \*  No 32 kHz CPU operation, realtime clock time base
- No 32 kHz CPU operation, no realtime clock time base

Note: When an asterisked item is selected, "crystal resonator" is necessary for subsystem oscillator (X1 X2).

### 3. ROM Code Data Organization

For a microcomputer with EPROM mounted (including a ZTAT™ microcomputer), specify the combined upper/lower type.

- Combined lower/upper type
  - Both the lower 5 data bits (L) and the upper 5 data bits (U) are written to a single EPROM in the order LULULU...
- Separate lower/upper type
  - The lower 5 data bits (L) and upper 5 data bits (U) are written to separate EPROMs respectively.

### 4. System Oscillator (OSC1-OSC2)

<input type="checkbox"/> Ceramic oscillator	f =	MHz
<input type="checkbox"/> Crystal oscillator	f =	MHz
<input type="checkbox"/> External clock	f =	MHz

---

## HD404889/HD404899/HD404878/HD404868 Series

---

### 5. Subsystem Oscillator (X1 X2)

---

- |  |                |
|--|----------------|
| <input type="checkbox"/> Not used          | —              |
| <input type="checkbox"/> Crystal resonator | f = 32.768 kHz |
- 

### 6. Stop Mode

---

- |  |
|--|
| <input type="checkbox"/> Yes (used)    |
| <input type="checkbox"/> No (not used) |
- 

### 7. Package

---

- |                                  |
|----------------------------------|
| <input type="checkbox"/> FP-80A  |
| <input type="checkbox"/> TFP-80C |
| <input type="checkbox"/> Chip    |
- 

Note: The specifications of shipped chips differ from those of the package product. Please contact our sales staff for details.

# HD404889/HD404899/HD404878/HD404868 Series

## Option List HD404874, HD404878, HCD404878

Please check off the appropriate applications and enter the necessary information.

Date of order	Year	Month	Day
Customer			
Department			
Name			
ROM code name			
LSI number (Hitachi entry)			

### 1. ROM Size

- |                                    |          |
|------------------------------------|----------|
| <input type="checkbox"/> HD404874  | 4 kwords |
| <input type="checkbox"/> HD404878  | 8 kwords |
| <input type="checkbox"/> HCD404878 | 8 kwords |

### 2. Function Options

- \*  32 kHz CPU operation, realtime clock time base
- \*  No 32 kHz CPU operation, realtime clock time base
- No 32 kHz CPU operation, no realtime clock time base

Note: When an asterisked item is selected, "crystal resonator" is necessary for subsystem oscillator (X1 X2).

### 3. ROM Code Data Organization

For a microcomputer with EPROM mounted (including a ZTAT™ microcomputer), specify the combined upper/lower type.

- Combined lower/upper type
- Both the lower 5 data bits (L) and the upper 5 data bits (U) are written to a single EPROM in the order LULULU...
- Separate lower/upper type
- The lower 5 data bits (L) and upper 5 data bits (U) are written to separate EPROMs respectively.

### 4. System Oscillator (OSC1-OSC2)

- |   |     |     |
|---|-----|-----|
| <input type="checkbox"/> Ceramic oscillator | f = | MHz |
| <input type="checkbox"/> Crystal oscillator | f = | MHz |
| <input type="checkbox"/> External clock     | f = | MHz |

### 5. Subsystem Oscillator (X1 X2)

- |  |                |
|--|----------------|
| <input type="checkbox"/> Not used          | —              |
| <input type="checkbox"/> Crystal resonator | f = 32.768 kHz |

### 6. Stop Mode

- |  |
|--|
| <input type="checkbox"/> Yes (used)    |
| <input type="checkbox"/> No (not used) |

### 7. Package

- |                                  |
|----------------------------------|
| <input type="checkbox"/> FP-80A  |
| <input type="checkbox"/> TFP-80C |
| <input type="checkbox"/> Chip    |

Note: The specifications of shipped chips differ from those of the package product. Please contact our sales staff for details.

**Option List HD404864, HD404868**

Please check off the appropriate applications and enter the necessary information.

Date of order	Year	Month	Day
Customer			
Department			
Name			
ROM code name			
LSI number (Hitachi entry)			

**1. ROM Size**

- |                                   |          |
|-----------------------------------|----------|
| <input type="checkbox"/> HD404864 | 4 kwords |
| <input type="checkbox"/> HD404868 | 8 kwords |

**2. Function Options**

- |                            |  |
|----------------------------|--|
| * <input type="checkbox"/> | 32 kHz CPU operation, realtime clock time base       |
| * <input type="checkbox"/> | No 32 kHz CPU operation, realtime clock time base    |
| <input type="checkbox"/>   | No 32 kHz CPU operation, no realtime clock time base |

Note: When an asterisked item is selected, "crystal resonator" is necessary for subsystem oscillator (X1 X2).

**3. ROM Code Data Organization**

For a microcomputer with EPROM mounted (including a ZTAT™ microcomputer), specify the combined upper/lower type.

- |                          |                           |   |
|--------------------------|---------------------------|---|
| <input type="checkbox"/> | Combined lower/upper type | • Both the lower 5 data bits (L) and the upper 5 data bits (U) are written to a single EPROM in the order LULULU... |
| <input type="checkbox"/> | Separate lower/upper type | • The lower 5 data bits (L) and upper 5 data bits (U) are written to separate EPROMs respectively.                  |

**4. System Oscillator (OSC1-OSC2)**

- |                          |                    |     |     |
|--------------------------|--------------------|-----|-----|
| <input type="checkbox"/> | Ceramic oscillator | f = | MHz |
| <input type="checkbox"/> | Crystal oscillator | f = | MHz |
| <input type="checkbox"/> | External clock     | f = | MHz |

**5. Subsystem Oscillator (X1 X2)**

- |                          |                   |                |
|--------------------------|-------------------|----------------|
| <input type="checkbox"/> | Not used          | —              |
| <input type="checkbox"/> | Crystal resonator | f = 32.768 kHz |

**6. Stop Mode**

- |                          |               |
|--------------------------|---------------|
| <input type="checkbox"/> | Yes (used)    |
| <input type="checkbox"/> | No (not used) |

**7. Package**

- |                          |        |
|--------------------------|--------|
| <input type="checkbox"/> | FP-64A |
| <input type="checkbox"/> | DP-64S |

## **Cautions**

1. Hitachi neither warrants nor grants licenses of any rights of Hitachi's or any third party's patent, copyright, trademark, or other intellectual property rights for information contained in this document. Hitachi bears no responsibility for problems that may arise with third party's rights, including intellectual property rights, in connection with use of the information contained in this document.
2. Products and product specifications may be subject to change without notice. Confirm that you have received the latest product standards or specifications before final design, purchase or use.
3. Hitachi makes every attempt to ensure that its products are of high quality and reliability. However, contact Hitachi's sales office before using the product in an application that demands especially high quality and reliability or where its failure or malfunction may directly threaten human life or cause risk of bodily injury, such as aerospace, aeronautics, nuclear power, combustion control, transportation, traffic, safety equipment or medical equipment for life support.
4. Design your application so that the product is used within the ranges guaranteed by Hitachi particularly for maximum rating, operating supply voltage range, heat radiation characteristics, installation conditions and other characteristics. Hitachi bears no responsibility for failure or damage when used beyond the guaranteed ranges. Even within the guaranteed ranges, consider normally foreseeable failure rates or failure modes in semiconductor devices and employ systemic measures such as fail-safes, so that the equipment incorporating Hitachi product does not cause bodily injury, fire or other consequential damage due to operation of the Hitachi product.
5. This product is not designed to be radiation resistant.
6. No one is permitted to reproduce or duplicate, in any form, the whole or part of this document without written approval from Hitachi.
7. Contact Hitachi's sales office for any questions regarding this document or Hitachi semiconductor products.

This datasheet has been downloaded from:

[www.DatasheetCatalog.com](http://www.DatasheetCatalog.com)

Datasheets for electronic components.



LittleDiode supplies new, hard to find or obsolete electronic components and semiconductors all over the world.

With over two million different components listed you are sure to find the part you need.

Feel free to visit us today at our online store:

[LittleDiode.com](http://LittleDiode.com)

Looking forward to providing you with the best possible service.