

ARF449A ARF449B

Common
Source

RF POWER MOSFETS N-CHANNEL ENHANCEMENT MODE

150V 150W 120MHz

The ARF449A and ARF449B comprise a symmetric pair of common source RF power transistors designed for push-pull scientific, commercial, medical and industrial RF power amplifier applications up to 120 MHz.

- **Specified 150 Volt, 81.36 MHz Characteristics:**
 - Output Power = 150 Watts.
 - Gain = 13dB (Class C)
 - Efficiency = 75%
- **Low Cost Common Source RF Package.**
- **Very High Breakdown for Improved Ruggedness.**
- **Low Thermal Resistance.**
- **Nitride Passivated Die for Improved Reliability.**

MAXIMUM RATINGS

All Ratings: $T_C = 25^\circ\text{C}$ unless otherwise specified.

Symbol	Parameter	ARF449A/449B	UNIT
V_{DSS}	Drain-Source Voltage	450	Volts
V_{DGO}	Drain-Gate Voltage	450	
I_D	Continuous Drain Current @ $T_C = 25^\circ\text{C}$	9	Amps
V_{GS}	Gate-Source Voltage	± 30	Volts
P_D	Total Power Dissipation @ $T_C = 25^\circ\text{C}$	165	Watts
$R_{\theta JC}$	Junction to Case	0.76	$^\circ\text{C/W}$
T_J, T_{STG}	Operating and Storage Junction Temperature Range	-55 to 150	$^\circ\text{C}$
T_L	Lead Temperature: 0.063" from Case for 10 Sec.	300	

STATIC ELECTRICAL CHARACTERISTICS

Symbol	Characteristic / Test Conditions	MIN	TYP	MAX	UNIT
BV_{DSS}	Drain-Source Breakdown Voltage ($V_{GS} = 0V, I_D = 250 \mu\text{A}$)	450			Volts
$V_{DS(ON)}$	On State Drain Voltage ^① ($I_D(ON) = 5A, V_{GS} = 10V$)			4	
I_{DSS}	Zero Gate Voltage Drain Current ($V_{DS} = V_{DSS}, V_{GS} = 0V$)			25	μA
	Zero Gate Voltage Drain Current ($V_{DS} = 0.8 V_{DSS}, V_{GS} = 0V, T_C = 125^\circ\text{C}$)			250	
I_{GSS}	Gate-Source Leakage Current ($V_{GS} = \pm 30V, V_{DS} = 0V$)			± 100	nA
g_{fs}	Forward Transconductance ($V_{DS} = 25V, I_D = 5A$)	3	5.8		mhos
$V_{GS(TH)}$	Gate Threshold Voltage ($V_{DS} = V_{GS}, I_D = 50mA$)	2		5	Volts

 **CAUTION:** These Devices are Sensitive to Electrostatic Discharge. Proper Handling Procedures Should Be Followed.

APT Website - <http://www.advancedpower.com>

USA
405 S.W. Columbia Street

EUROPE
Avenue J.F. Kennedy Bât B4 Parc Cadéra Nord

Bend, Oregon 97702-1035

F-33700 Merignac - France

Phone: (541) 382-8028

Phone: (33) 5 57 92 15 15

FAX: (541) 388-0364

FAX: (33) 5 56 47 97 61

DYNAMIC CHARACTERISTICS

ARF449A/449B

Symbol	Characteristic	Test Conditions	MIN	TYP	MAX	UNIT
C_{iss}	Input Capacitance	$V_{GS} = 0V$ $V_{DS} = 150V$ $f = 1\text{ MHz}$		980	1200	pF
C_{oss}	Output Capacitance			87	120	
C_{rss}	Reverse Transfer Capacitance			25	40	
$t_{d(on)}$	Turn-on Delay Time	$V_{GS} = 15V$ $V_{DD} = 0.5 V_{DSS}$ $I_D = I_{D[Cont.]} @ 25^\circ C$ $R_G = 1.6\Omega$		5	10	ns
t_r	Rise Time			3.1	7	
$t_{d(off)}$	Turn-off Delay Time			15	25	
t_f	Fall Time			3	7	

FUNCTIONAL CHARACTERISTICS

Symbol	Characteristic	Test Conditions	MIN	TYP	MAX	UNIT
G_{PS}	Common Source Amplifier Power Gain	$f = 81.36\text{ MHz}$	12	13		dB
η	Drain Efficiency	$V_{GS} = 0V$ $V_{DD} = 150V$	70	75		%
Ψ	Electrical Ruggedness VSWR 20:1	$P_{out} = 150W$	No Degradation in Output Power			

① Pulse Test: Pulse width < 380 μ S, Duty Cycle < 2%

APT Reserves the right to change, without notice, the specifications and information contained herein.

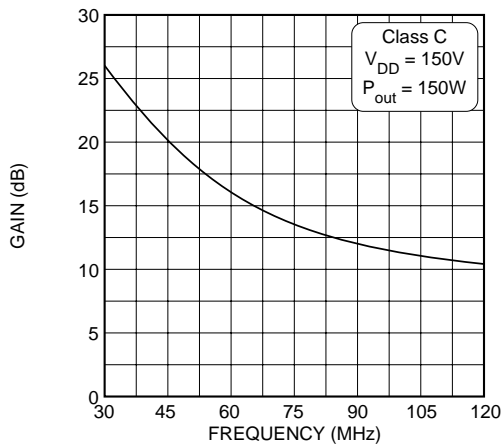

Figure 1, Typical Gain vs Frequency

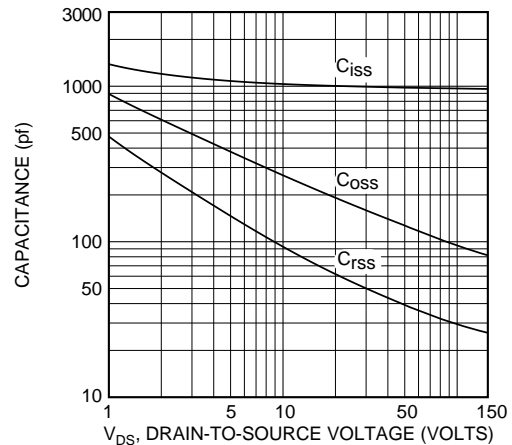

Figure 2, Typical Capacitance vs. Drain-to-Source Voltage

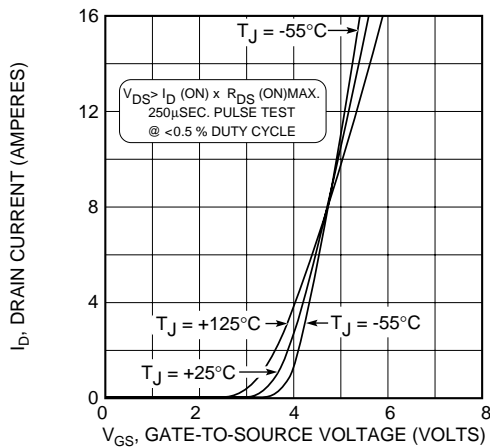

Figure 3, Typical Transfer Characteristics

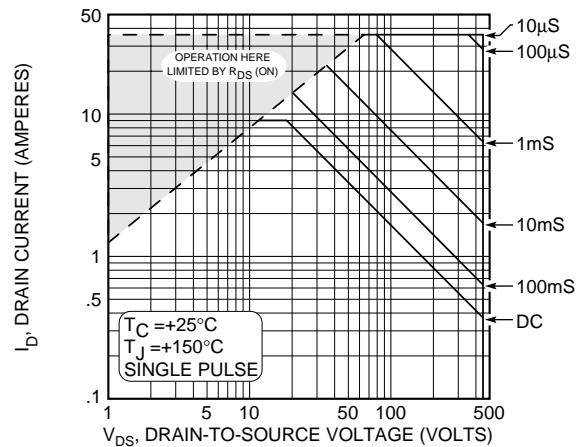

Figure 4, Typical Maximum Safe Operating Area

ARF449A/449B

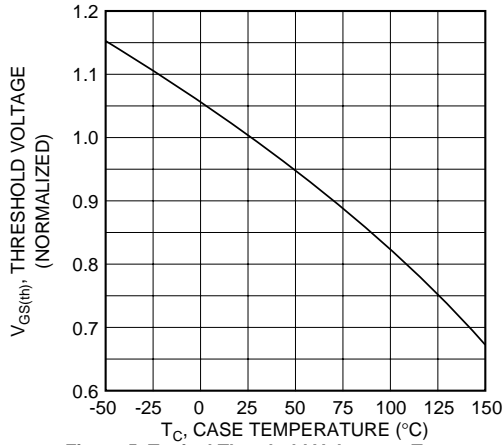

Figure 5, Typical Threshold Voltage vs Temperature

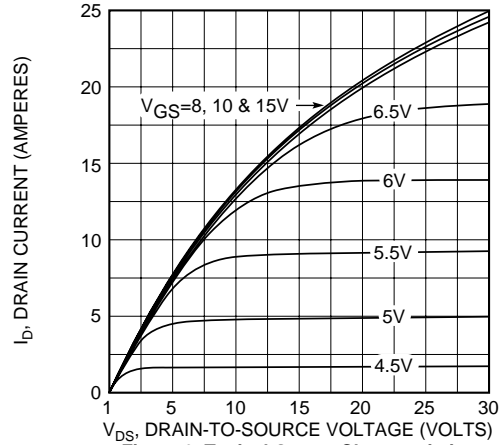

Figure 6, Typical Output Characteristics

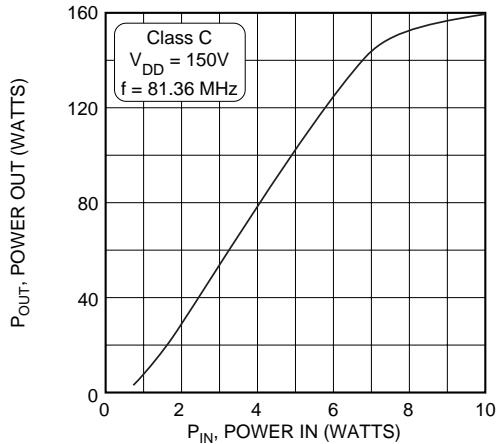

Figure 7, Typical Power Out vs Power In

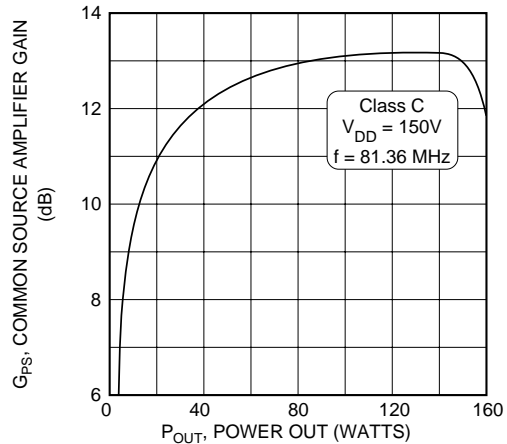

Figure 8, Typical Common Source Amplifier Gain vs Power Out

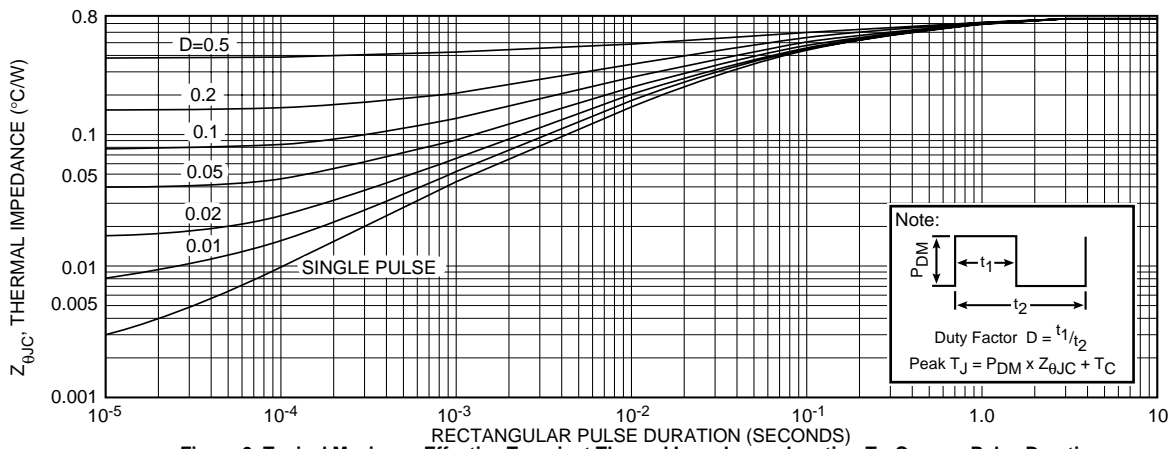

Figure 9, Typical Maximum Effective Transient Thermal Impedance, Junction-To-Case vs Pulse Duration

Table 1 - Typical Class C Large Signal Input-Output Impedance

Freq. (MHz)	Z _{in} (Ω)	Z _{oL} (Ω)
2.0	23.00 - j 7.0	93.0 - j 10
13.5	4.30 - j 9.1	63.0 - j 43
27.0	1.00 - j 4.2	32.0 - j 43
40.0	0.42 - j 1.7	17.5 - j 34
65.0	0.35 + j 1.1	7.7 - j 22
80.0	0.56 + j 2.5	5.1 - j 16
100.0	0.90 + j 3.8	3.4 - j 12

Z_{in} - gate shunted by 25Ω

Z_{oL} - conjugate of optimum load impedance for 150W at 150V

81.36 MHz Test Circuit

Parts List

- C1 -- 680pF Unelco
- C2-C4 -- Arco 463 Mica Trimmer
- C5-C7 -- 1nF 500V COG chip
- L1 -- 0.8" #18 AWG into hairpin ~19nH
- L2-L3 -- 3t #18 AWG .25" ID ~50nH
- L4 -- 10t #18 AWG .25" ID ~470nH
- L5 -- VK200-4B ferrite choke ~3uH
- R1 -- 25 Ohm 1/2W Carbon
- T1 -- 4:1 Broadband Transformer

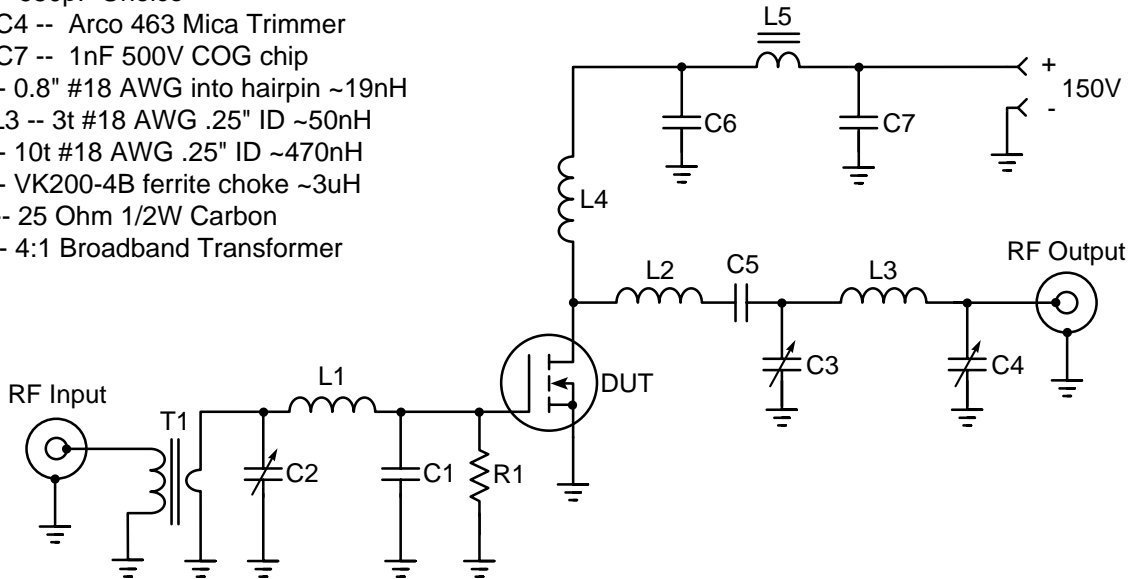

TO-247 Package Outline

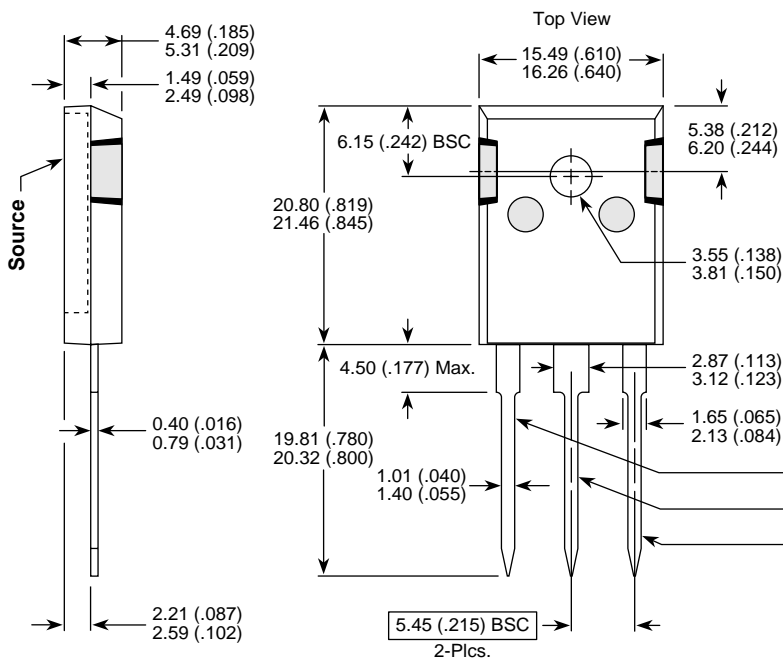

Dimensions in Millimeters and (Inches)

NOTE: The ARF446 and ARF447 comprise a symmetric pair of RF power transistors and meet the same electrical specifications. The device pin-outs are the mirror image of each other to allow ease of use as a push-pull pair.

Device	
ARF449A	ARF449B
Gate	Drain
Source	Source
Drain	Gate



LittleDiode supplies new, hard to find or obsolete electronic components and semiconductors all over the world.

With over two million different components listed you are sure to find the part you need.

Feel free to visit us today at our online store:

LittleDiode.com

Looking forward to providing you with the best possible service.