

## DS7833/DS8833/DS7835/DS8835 Quad TRI-STATE® Bus Transceivers

### General Description

This family of TRI-STATE bus transceivers offers extreme versatility in bus organized data transmission systems. The data bus may be unterminated, or terminated DC or AC, at one or both ends. Drivers in the third (high impedance) state load the data bus with a negligible leakage current. The receiver input current is low allowing at least 100 driver/receiver pairs to utilize a single bus. The bus loading is unchanged when  $V_{CC} = 0V$ . The receiver incorporates hysteresis to provide greater noise immunity. All devices utilize a high current TRI-STATE output driver. The DS7833/DS8833 and DS7835/DS8835 employ TRI-STATE outputs on the receiver also.

The DS7833/DS8833 are non-inverting quad transceivers with a common inverter driver disable control and common inverter receiver disable control.

The DS7835/DS8835 are inverting quad transceivers with a common inverter driver disable control and a common inverter receiver disable control.

### Features

- Receiver hysteresis 400 mV typ
- Receiver noise immunity 1.4V typ
- Bus terminal current for normal  $V_{CC}$  or  $V_{CC} = 0V$  80  $\mu A$  max
- Receivers
  - Sink 16 mA at 0.4V max
  - Source 2.0 mA (Mil) at 2.4V min  
5.2 mA (Com) at 2.4V min
- Drivers
  - Sink 50 mA at 0.5V max  
32 mA at 0.4V max
  - Source 10.4 mA (Com) at 2.4V min  
5.2 mA (Mil) at 2.4V min
- Drivers have TRI-STATE outputs
- DS7833/DS8833, DS7835/DS8835 receivers have TRI-STATE outputs
- Capable of driving 100 $\Omega$  DC—terminated buses
- Compatible with Series 54/74

### Connection Diagram

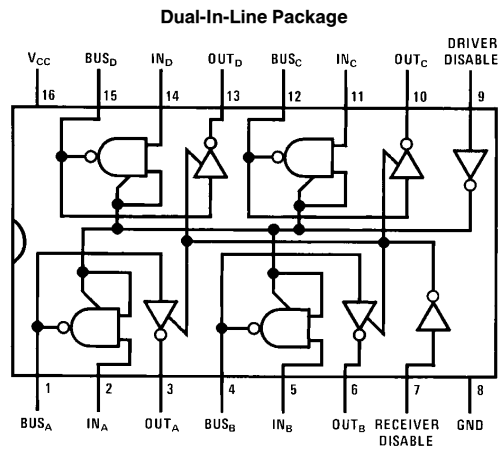
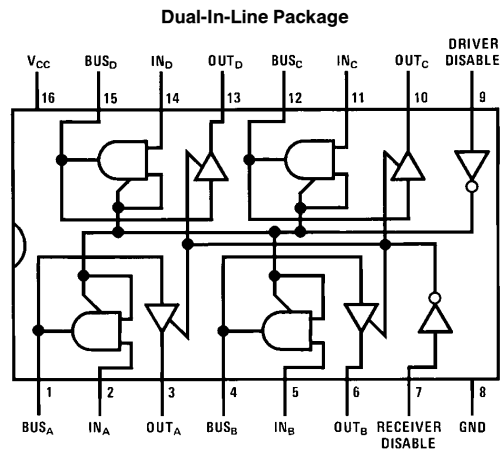

TRI-STATE® is a registered trademark of National Semiconductor Corp.

## Absolute Maximum Ratings (Note 1)

If Military/Aerospace specified devices are required, please contact the National Semiconductor Sales Office/Distributors for availability and specifications.

Supply Voltage	7.0V
Input Voltage	5.5V
Output Voltage	5.5V
Storage Temperature	-65°C to +150°C
Maximum Power Dissipation* at 25°C	
Cavity Package	1509 mW
Molded Package	1476 mW
Lead Temperature (Soldering, 4 sec.)	260°C

\*Derate cavity package 10.1 mW/°C above 25°C; derate molded package 11.8 mW/°C above 25°C.

## Operating Conditions

	Min	Max	Units
Supply Voltage, $V_{CC}$			
DS7833/DS7835	4.5	5.5	V
DS8833/DS8835	4.75	5.25	V
Temperature ( $T_A$ )			
DS7833/DS7835	-55	+125	°C
DS8833/DS8835	0	+70	°C

## Electrical Characteristics (Notes 2 and 3)

Symbol	Parameter	Conditions	Min	Typ	Max	Units	
<b>DISABLE/DRIVER INPUT</b>							
$V_{IH}$	High Level Input Voltages	$V_{CC} = \text{Min}$	2.0			V	
$V_{IL}$	Low Level Input Voltage	$V_{CC} = \text{Min}$	DS7833, DS8833, DS8835		0.8	V	
			DS7835		0.7		
$I_{IH}$	High Level Input Current	$V_{CC} = \text{Max}$	$V_{IN} = 2.4V$		40	$\mu A$	
			$V_{IN} = 5.5V$		1.0	mA	
$I_{IL}$	Low Level Input Current	$V_{CC} = \text{Max}, V_{IN} = 0.4V$		-1.0	-1.6	mA	
$V_{CL}$	Input Clamp Diode	$V_{CC} = 5.0V, I_{IN} = -12 \text{ mA}, T_A = 25^\circ C$		-0.8	-1.5	V	
$I_{IT}$	Driver Low Level Disabled Input Current	Driver Disable Input = 2.0V, $V_{IN} = 0.4V$			-40	$\mu A$	
<b>RECEIVER INPUT/BUS OUTPUT</b>							
$V_{TH}$	High Level Threshold Voltage		DS7833, DS7835	1.4	1.75	2.1	V
			DS8833, DS8835	1.5	1.75	2.0	V
$V_{TL}$	Low Level Threshold Voltage		DS7833, DS7835	0.8	1.35	1.6	V
			DS8833, DS8835	0.8	1.35	1.5	V
$I_S$	Bus Current, Output Disabled or High	$V_{BUS} = 4.0V$	$V_{CC} = \text{Max}$		25	80	$\mu A$
			$V_{CC} = 0V$		5.0	80	$\mu A$
		$V_{CC} = \text{Max}, V_{BUS} = 0.4V$		-2.0	-40	$\mu A$	
$V_{OH}$	Logic "1" Output Voltage	$V_{CC} = \text{Min}$	$I_{OUT} = -5.2 \text{ mA}$	DS7833, DS7835	2.4	2.75	V
			$I_{OUT} = -10.4 \text{ mA}$	DS8833, DS8835	2.4	2.75	V
$V_{OL}$	Logic "0" Output Voltage	$V_{CC} = \text{Min}$	$I_{OUT} = 50 \text{ mA}$		0.28	0.5	V
			$I_{OUT} = 32 \text{ mA}$			0.4	V
$I_{OS}$	Output Short Circuit Current	$V_{CC} = \text{Max}, (\text{Note } 4)$	-40	-62	-120	mA	
<b>RECEIVER OUTPUT</b>							
$V_{OH}$	Logic "1" Output Voltage	$V_{CC} = \text{Min}$	$I_{OUT} = -2.0 \text{ mA}$	DS7833, DS7835	2.4	3.0	V
			$I_{OUT} = -5.2 \text{ mA}$	DS8833, DS8835	2.4	2.9	V
$V_{OL}$	Logic "0" Output Voltage	$V_{CC} = \text{Min}, I_{OUT} = 16 \text{ mA}$		0.22	0.4	V	
$I_{OT}$	Output Disabled Current	$V_{CC} = \text{Max}, \text{Disable Inputs} = 2.0V$	$V_{OUT} = 2.4V$			40	$\mu A$
			$V_{OUT} = 0.4V$			-40	$\mu A$

## Electrical Characteristics (Notes 2 and 3) (Continued)

Symbol	Parameter	Conditions	Min	Typ	Max	Units	
<b>RECEIVER OUTPUT (Continued)</b>							
I <sub>OS</sub>	Output Short Circuit Current	V <sub>CC</sub> = Max, (Note 4)	DS7833, DS7835	28	-40	-70	mA
			DS8833, DS8835	-30		-70	mA
I <sub>CC</sub>	Supply Current	V <sub>CC</sub> = Max	DS7833, DS8833		84	116	mA
			DS7835, DS8835		75	95	mA

**Note 1:** "Absolute Maximum Ratings" are those values beyond which the safety of the device cannot be guaranteed. Except for "Operating Temperature Range" they are not meant to imply that the devices should be operated at these limits. The table of "Electrical Characteristics" provides conditions for actual device operation.

**Note 2:** Unless otherwise specified min/max limits apply across the -55°C to +125°C temperature range for the DS7833, DS7835 and across the 0°C to +70°C range for the DS8833, DS8835. All typicals are given for V<sub>CC</sub> = 5.0V and T<sub>A</sub> = 25°C.

**Note 3:** All currents into device pins shown as positive, out of device pins as negative, all voltages referenced to ground unless otherwise noted. All values shown as max or min on absolute value basis.

**Note 4:** Only one output at a time should be shorted.

## Switching Characteristics V<sub>CC</sub> = 5.0V, T<sub>A</sub> = 25°C

Symbol	Parameter	Conditions	Min	Typ	Max	Units
t <sub>pd0</sub>	Propagation Delay to a Logic "0" from Input to Bus	(Figure 1) DS7833/DS8833		14	30	ns
		DS7835/DS8835		10	20	ns
t <sub>pd1</sub>	Propagation Delay to a Logic "1" from Input to Bus	(Figure 1) DS7833/DS8833		14	30	ns
		DS7835/DS8835		11	30	ns
t <sub>pd0</sub>	Propagation Delay to a Logic "0" from Bus to Input	(Figure 2) DS7833/DS8833		24	45	ns
		DS7835/DS8835		16	35	ns
t <sub>pd1</sub>	Propagation Delay to a Logic "1" from Bus to Input	(Figure 2) DS7833/DS8833		12	30	ns
		DS7835/DS8835		18	30	ns
t <sub>PHZ</sub>	Delay from Disable Input to High Impedance State (from Logic "1" Level)	C <sub>L</sub> = 5.0 pF, (Figures 1 and 2) Driver		8.0	20	ns
		Receiver		6.0	15	ns
t <sub>PLZ</sub>	Delay from Disable Input to High Impedance State (from Logic "0" Level)	C <sub>L</sub> = 5.0 pF, (Figures 1 and 2) Driver		20	35	ns
		Receiver		13	25	ns
t <sub>PZH</sub>	Delay from Disable Input to Logic "1" Level (from High Impedance State)	C <sub>L</sub> = 5.0 pF, (Figures 1 and 2) Driver		24	40	ns
		Receiver		16	35	ns
t <sub>PZL</sub>	Delay from Disable Input to Logic "0" Level (from High Impedance State)	C <sub>L</sub> = 5.0 pF, (Figures 1 and 2) Driver		19	35	ns
		Receiver DS7833/DS8833		15	30	ns
		Receiver DS7835/DS8835		33	50	ns

## AC Test Circuits

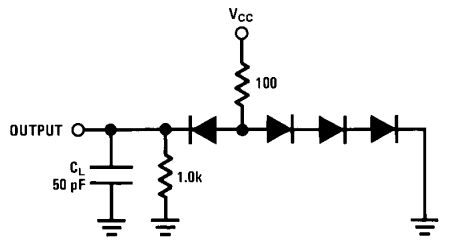

FIGURE 1. Driver Output Load

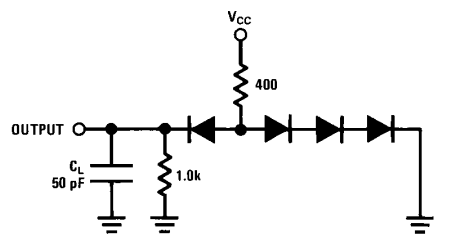
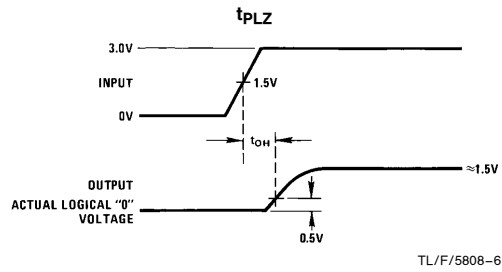
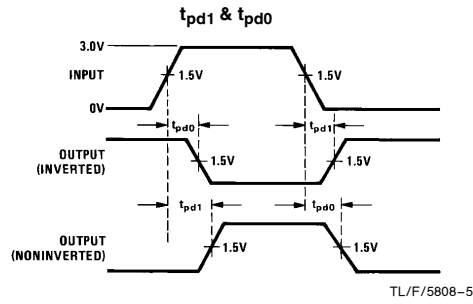
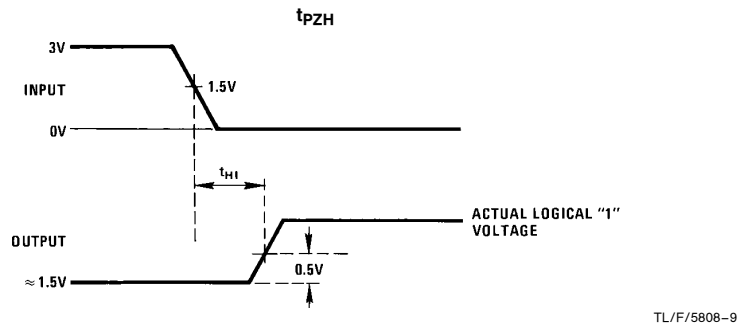
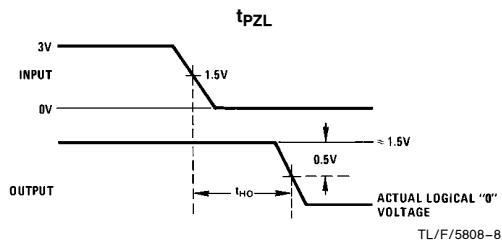
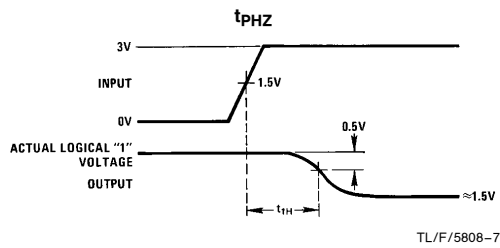

FIGURE 2. Receiver Output Load

# Switching Time Waveforms



f = 1 MHz  
 $t_r = t_f \leq 10$  ns (10% to 90%)  
 DUTY CYCLE = 50%



**Physical Dimensions** inches (millimeters)

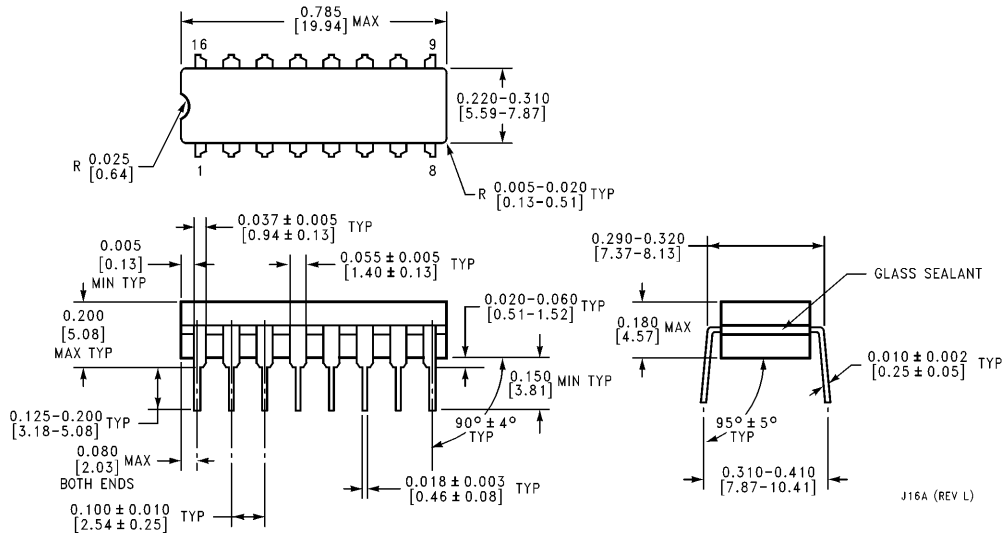

**Ceramic Dual-In-Line Package (J)**  
**Order Number DS7833J or DS7835J**  
**NS Package Number J16A**

J16A (REV L)

**Physical Dimensions** inches (millimeters) (Continued)

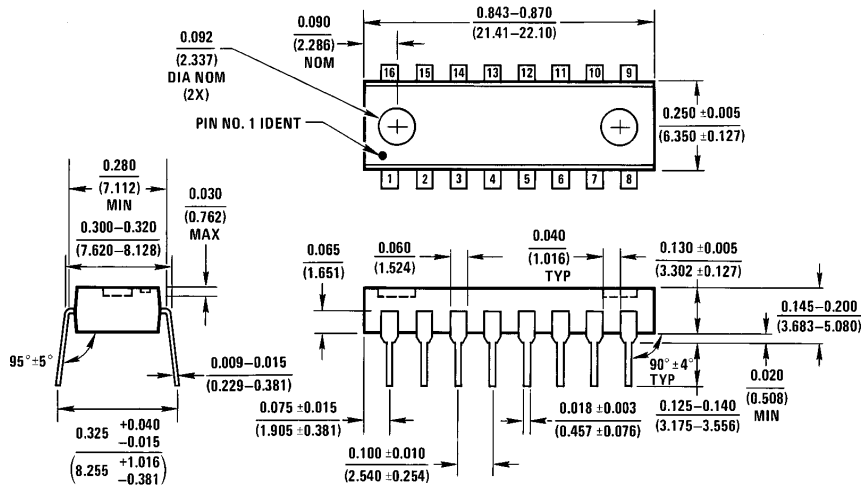

**Molded Dual-In-Line Package (N)**  
**Order Number DS8833N or DS8835N**  
**NS Package Number N16A**

N16A (REV E)

**LIFE SUPPORT POLICY**

NATIONAL'S PRODUCTS ARE NOT AUTHORIZED FOR USE AS CRITICAL COMPONENTS IN LIFE SUPPORT DEVICES OR SYSTEMS WITHOUT THE EXPRESS WRITTEN APPROVAL OF THE PRESIDENT OF NATIONAL SEMICONDUCTOR CORPORATION. As used herein:

1. Life support devices or systems are devices or systems which, (a) are intended for surgical implant into the body, or (b) support or sustain life, and whose failure to perform, when properly used in accordance with instructions for use provided in the labeling, can be reasonably expected to result in a significant injury to the user.
2. A critical component is any component of a life support device or system whose failure to perform can be reasonably expected to cause the failure of the life support device or system, or to affect its safety or effectiveness.



**National Semiconductor Corporation**  
 1111 West Bardin Road  
 Arlington, TX 76017  
 Tel: 1(800) 272-9959  
 Fax: 1(800) 737-7018

<http://www.national.com>

**National Semiconductor Europe**

Fax: +49 (0) 180-530 85 86  
 Email: [europe.support@nsc.com](mailto:europe.support@nsc.com)  
 Deutsch Tel: +49 (0) 180-530 85 85  
 English Tel: +49 (0) 180-532 78 32  
 Français Tel: +49 (0) 180-532 93 58  
 Italiano Tel: +49 (0) 180-534 16 80

**National Semiconductor Hong Kong Ltd.**

19th Floor, Straight Block,  
 Ocean Centre, 5 Canton Rd.  
 Tsimshatsui, Kowloon  
 Hong Kong  
 Tel: (852) 2737-1600  
 Fax: (852) 2736-9960

**National Semiconductor Japan Ltd.**

Tel: 81-043-299-2308  
 Fax: 81-043-299-2408

National does not assume any responsibility for use of any circuitry described, no circuit patent licenses are implied and National reserves the right at any time without notice to change said circuitry and specifications.

This datasheet has been downloaded from:

[www.DatasheetCatalog.com](http://www.DatasheetCatalog.com)

Datasheets for electronic components.

# National Semiconductor was acquired by Texas Instruments.

[http://www.ti.com/corp/docs/investor\\_relations/pr\\_09\\_23\\_2011\\_national\\_semiconductor.html](http://www.ti.com/corp/docs/investor_relations/pr_09_23_2011_national_semiconductor.html)

This file is the datasheet for the following electronic components:

DS7835J - <http://www.ti.com/product/ds7835j?HQS=TI-null-null-dscatalog-df-pf-null-ww>

DS7833J - <http://www.ti.com/product/ds7833j?HQS=TI-null-null-dscatalog-df-pf-null-ww>

DS8835N - <http://www.ti.com/product/ds8835n?HQS=TI-null-null-dscatalog-df-pf-null-ww>

DS8833N - <http://www.ti.com/product/ds8833n?HQS=TI-null-null-dscatalog-df-pf-null-ww>



LittleDiode supplies new, hard to find or obsolete electronic components and semiconductors all over the world.

With over two million different components listed you are sure to find the part you need.

Feel free to visit us today at our online store:

[LittleDiode.com](http://LittleDiode.com)

Looking forward to providing you with the best possible service.