

# HD74HC373/HD74HC533

Octal D-type Transparent Latches (with 3-state outputs)  
Octal D-type Transparent Latches (with inverted 3-state outputs)

# HITACHI

## Description

When the latch enable input is high, the Q outputs of HD74HC373 will follow the D inputs and the Q outputs of HD74HC533 will follow the inversion of the D inputs. When the latch enable goes low, data at the D inputs will be retained at the outputs until latch enable returns high again. When a high logic level is applied to the output control input, all outputs go to a high impedance state, regardless of what signals are present at the other inputs and the state of the storage elements.

## Features

- High Speed Operation:  $t_{pd}$  (D to Q) = 16 ns typ ( $C_L = 50$  pF)
- High Output Current: Fanout of 15 LSTTL Loads
- Wide Operating Voltage:  $V_{CC} = 2$  to 6 V
- Low Input Current: 1  $\mu$ A max
- Low Quiescent Supply Current:  $I_{CC}$  (static) = 4  $\mu$ A max ( $T_a = 25^\circ\text{C}$ )

## Function Table

Output Control	Enable G	D	HD74HC373 Q	HD74HC533 $\bar{Q}$
L	H	H	H	L
L	H	L	L	H
L	L	X	No change	No change
H	X	X	Z	Z

X : irrelevant

Z : Off (high-impedance) state of a 3-state output.

# HD74HC373/HD74HC533

## Pin Arrangement

### HD74HC373

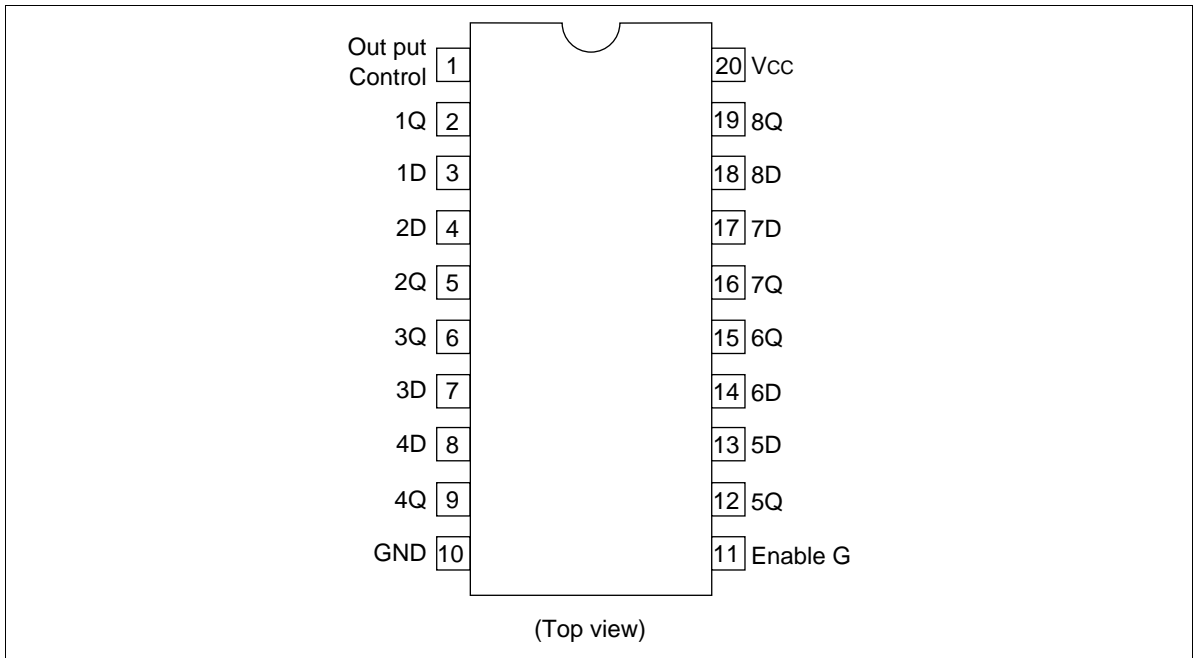

### HD74HC533

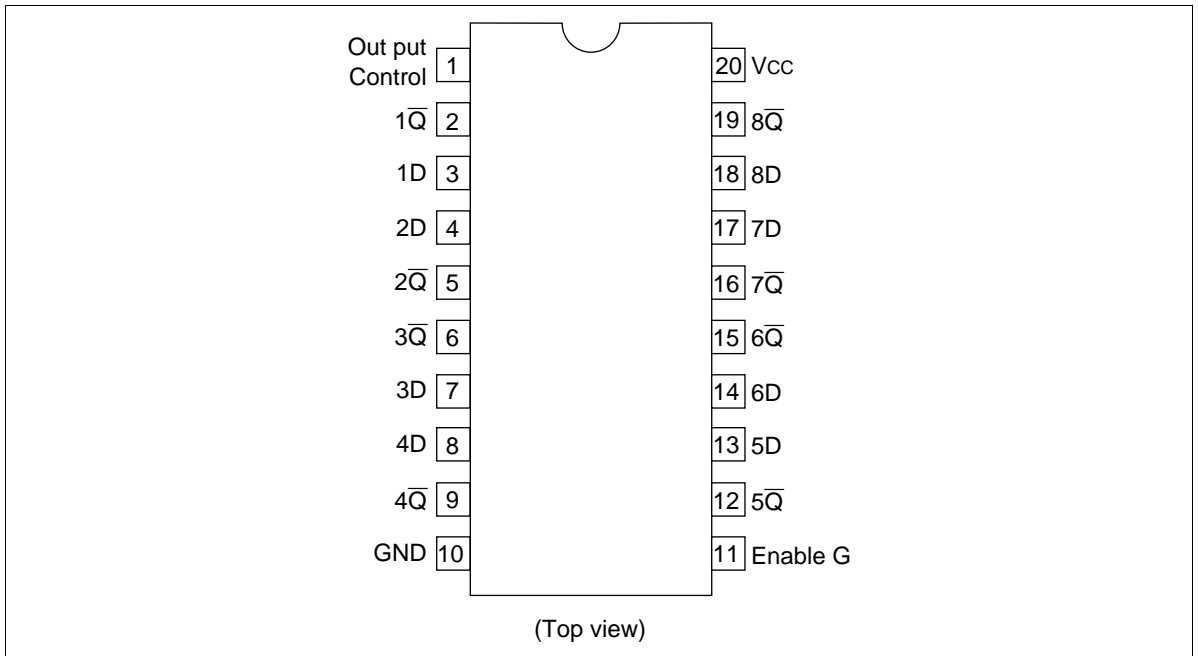

**HITACHI**

**Absolute Maximum Ratings**

Item	Symbol	Rating	Unit
Supply voltage range	$V_{CC}$	-0.5 to +7.0	V
Input voltage	$V_{IN}$	-0.5 to $V_{CC} + 0.5$	V
Output voltage	$V_{OUT}$	-0.5 to $V_{CC} + 0.5$	V
DC current drain per pin	$I_{OUT}$	$\pm 35$	mA
DC current drai per $V_{CC}$ GND	$I_{CC}, I_{GND}$	$\pm 75$	mA
DC input diode current	$I_{IK}$	$\pm 20$	mA
DC output diode current	$I_{OK}$	$\pm 20$	mA
Power Dissipation per package	$P_T$	500	mW
Storage temperature	Tstg	-65 to +150	$^{\circ}C$

**Block Diagram**

**HD74HC373**

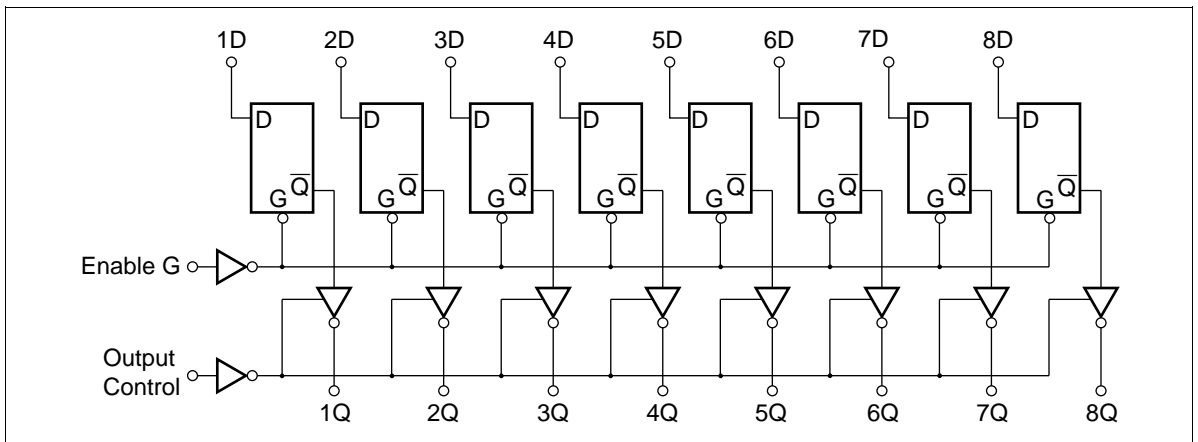

# HD74HC373/HD74HC533

## HD74HC533

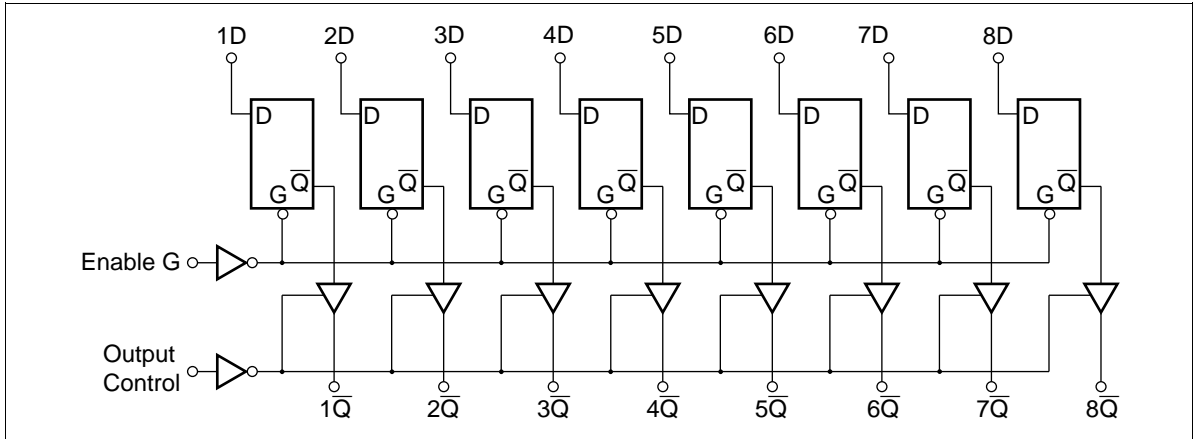

HITACHI

DC Characteristics

Item	Symbol	V <sub>CC</sub> (V)	Ta = 25°C		Ta = -40 to +85°C		Unit	Test Conditions			
			Min	Typ	Max	Min			Max		
Input voltage	V <sub>IH</sub>	2.0	1.5	—	—	1.5	—	V			
		4.5	3.15	—	—	3.15	—				
		6.0	4.2	—	—	4.2	—				
	V <sub>IL</sub>	2.0	—	—	0.5	—	0.5		V		
		4.5	—	—	1.35	—	1.35				
		6.0	—	—	1.8	—	1.8				
Output voltage	V <sub>OH</sub>	2.0	1.9	2.0	—	1.9	—	Vin = V <sub>IH</sub> or V <sub>IL</sub> I <sub>OH</sub> = -20 μA			
		4.5	4.4	4.5	—	4.4	—				
		6.0	5.9	6.0	—	5.9	—				
		4.5	4.18	—	—	4.13	—		I <sub>OH</sub> = -6 mA		
		6.0	5.68	—	—	5.63	—		I <sub>OH</sub> = -7.8 mA		
		6.0	—	0.0	0.1	—	0.1		Vin = V <sub>IH</sub> or V <sub>IL</sub> I <sub>OL</sub> = 20 μA		
	V <sub>OL</sub>	4.5	—	0.0	0.1	—	0.1				
		6.0	—	0.0	0.1	—	0.1				
		4.5	—	—	0.26	—	0.33	I <sub>OL</sub> = 6 mA			
		6.0	—	—	0.26	—	0.33	I <sub>OL</sub> = 7.8 mA			
		Off-state output current	I <sub>OZ</sub>	6.0	—	—	±0.5	—		±5.0	μA
		Input current	I <sub>in</sub>	6.0	—	—	±0.1	—	±1.0	μA	Vin = V <sub>CC</sub> or GND
Quiescent supply current	I <sub>CC</sub>	6.0	—	—	4.0	—	40	μA	Vin = V <sub>CC</sub> or GND, Iout = 0 μA		

# HD74HC373/HD74HC533

AC Characteristics ( $C_L = 50$  pF, Input  $t_r = t_f = 6$  ns)

Item	Symbol	$V_{CC}$ (V)	$T_a = 25^\circ\text{C}$		$T_a = -40$ to $+85^\circ\text{C}$		Unit	Test Conditions	
			Min	Typ	Max	Min			Max
Propagation delay time	$t_{PLH}$	2.0	—	—	150	—	190	ns	G to Q
		4.5	—	18	30	—	38		
		6.0	—	—	26	—	33		
	$t_{PHL}$	2.0	—	—	125	—	155	ns	D to Q
		4.5	—	16	25	—	31		
		6.0	—	—	21	—	26		
Output enable time	$t_{ZL}$	2.0	—	—	150	—	190	ns	
		4.5	—	12	30	—	38		
		6.0	—	—	26	—	33		
	$t_{ZH}$	2.0	—	—	150	—	190	ns	
		4.5	—	15	30	—	38		
		6.0	—	—	26	—	33		
Output disable time	$t_{LZ}$	2.0	—	—	150	—	190	ns	
		4.5	—	13	30	—	38		
		6.0	—	—	26	—	33		
	$t_{HZ}$	2.0	—	—	150	—	190	ns	
		4.5	—	16	30	—	38		
		6.0	—	—	26	—	33		
Setup time	$t_{su}$	2.0	100	—	—	125	—	ns	
		4.5	20	1	—	25	—		
		6.0	17	—	—	21	—		
Hold time	$t_h$	2.0	50	—	—	65	—	ns	
		4.5	10	1	—	13	—		
		6.0	9	—	—	11	—		
Pulse width	$t_w$	2.0	80	—	—	100	—	ns	
		4.5	16	6	—	20	—		
		6.0	14	—	—	17	—		
Output rise/fall time	$t_{TLH}$	2.0	—	—	60	—	75	ns	
	$t_{THL}$	4.5	—	4	12	—	15		
		6.0	—	—	10	—	13		
Input capacitance	$C_{in}$	—	—	5	10	—	10	pF	

HITACHI

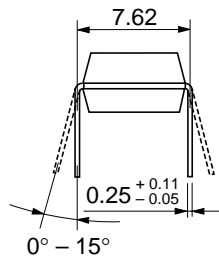
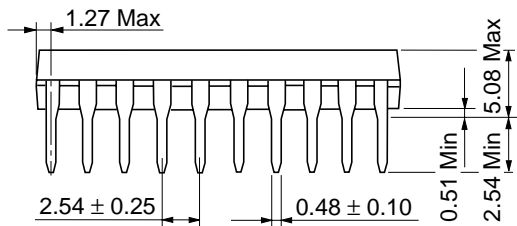
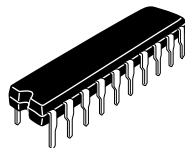
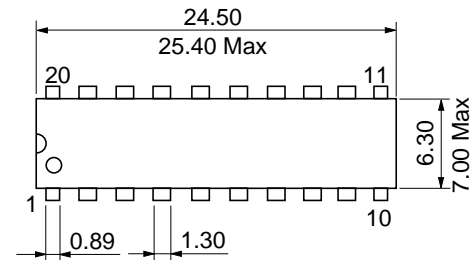

Hitachi Code	DP-20N
JEDEC	—
EIAJ	Conforms
Weight (reference value)	1.26 g

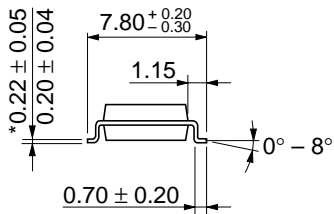
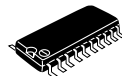
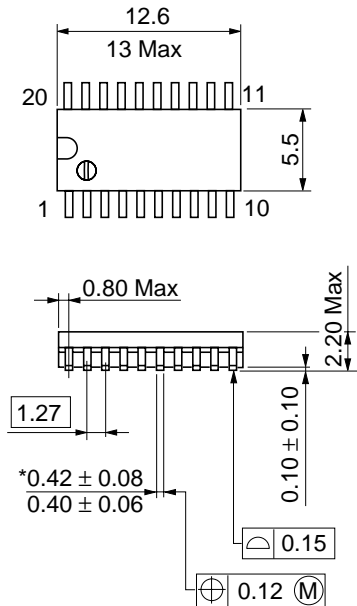

Hitachi Code	FP-20DA
JEDEC	—
EIAJ	Conforms
Weight (reference value)	0.31 g

\*Dimension including the plating thickness  
Base material dimension

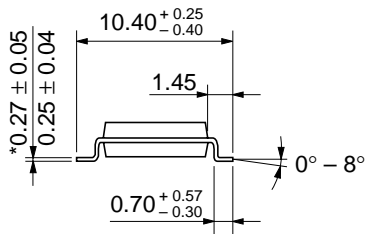
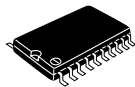
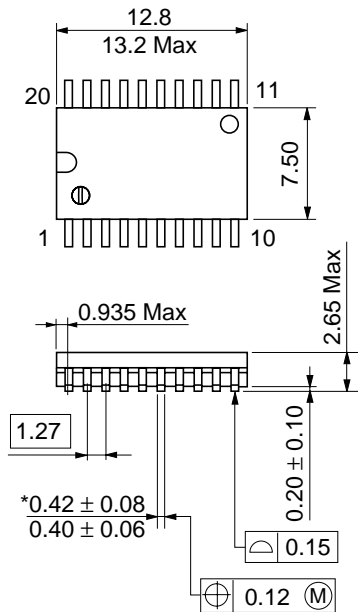

Hitachi Code	FP-20DB
JEDEC	Conforms
EIAJ	—
Weight (reference value)	0.52 g

\*Dimension including the plating thickness  
 Base material dimension

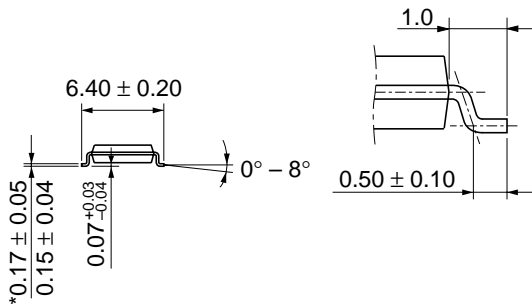
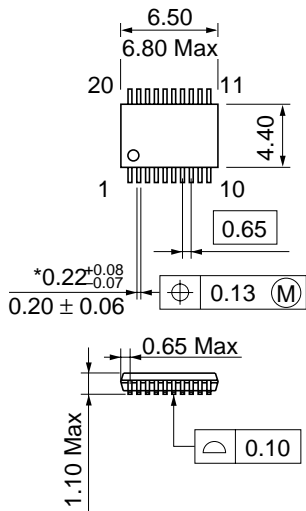

\*Dimension including the plating thickness  
Base material dimension

Hitachi Code	TTP-20DA
JEDEC	—
EIAJ	—
Weight (reference value)	0.07 g

## Cautions

1. Hitachi neither warrants nor grants licenses of any rights of Hitachi's or any third party's patent, copyright, trademark, or other intellectual property rights for information contained in this document. Hitachi bears no responsibility for problems that may arise with third party's rights, including intellectual property rights, in connection with use of the information contained in this document.
2. Products and product specifications may be subject to change without notice. Confirm that you have received the latest product standards or specifications before final design, purchase or use.
3. Hitachi makes every attempt to ensure that its products are of high quality and reliability. However, contact Hitachi's sales office before using the product in an application that demands especially high quality and reliability or where its failure or malfunction may directly threaten human life or cause risk of bodily injury, such as aerospace, aeronautics, nuclear power, combustion control, transportation, traffic, safety equipment or medical equipment for life support.
4. Design your application so that the product is used within the ranges guaranteed by Hitachi particularly for maximum rating, operating supply voltage range, heat radiation characteristics, installation conditions and other characteristics. Hitachi bears no responsibility for failure or damage when used beyond the guaranteed ranges. Even within the guaranteed ranges, consider normally foreseeable failure rates or failure modes in semiconductor devices and employ systemic measures such as fail-safes, so that the equipment incorporating Hitachi product does not cause bodily injury, fire or other consequential damage due to operation of the Hitachi product.
5. This product is not designed to be radiation resistant.
6. No one is permitted to reproduce or duplicate, in any form, the whole or part of this document without written approval from Hitachi.
7. Contact Hitachi's sales office for any questions regarding this document or Hitachi semiconductor products.

# HITACHI

## Hitachi, Ltd.

Semiconductor & Integrated Circuits.  
Nippon Bldg., 2-6-2, Ohte-machi, Chiyoda-ku, Tokyo 100-0004, Japan  
Tel: Tokyo (03) 3270-2111 Fax: (03) 3270-5109

URL      North America      : <http://semiconductor.hitachi.com/>  
             Europe                 : <http://www.hitachi-eu.com/hel/ecg>  
             Asia (Singapore)       : <http://www.has.hitachi.com.sg/grp3/sicd/index.htm>  
             Asia (Taiwan)             : [http://www.hitachi.com.tw/E/Product/SICD\\_Frame.htm](http://www.hitachi.com.tw/E/Product/SICD_Frame.htm)  
             Asia (HongKong)        : <http://www.hitachi.com.hk/eng/bo/grp3/index.htm>  
             Japan                        : <http://www.hitachi.co.jp/Sicd/indx.htm>

## For further information write to:

Hitachi Semiconductor  
(America) Inc.  
179 East Tasman Drive,  
San Jose, CA 95134  
Tel: <1> (408) 433-1990  
Fax: <1>(408) 433-0223

Hitachi Europe GmbH  
Electronic components Group  
Dornacher Straße 3  
D-85622 Feldkirchen, Munich  
Germany  
Tel: <49> (89) 9 9180-0  
Fax: <49> (89) 9 29 30 00

Hitachi Europe Ltd.  
Electronic Components Group.  
Whitebrook Park  
Lower Cookham Road  
Maidenhead  
Berkshire SL6 8YA, United Kingdom  
Tel: <44> (1628) 585000  
Fax: <44> (1628) 778322

Hitachi Asia Pte. Ltd.  
16 Collyer Quay #20-00  
Hitachi Tower  
Singapore 049318  
Tel: 535-2100  
Fax: 535-1533

Hitachi Asia Ltd.  
Taipei Branch Office  
3F, Hung Kuo Building, No.167,  
Tun-Hwa North Road, Taipei (105)  
Tel: <886> (2) 2718-3666  
Fax: <886> (2) 2718-8180

Hitachi Asia (Hong Kong) Ltd.  
Group III (Electronic Components)  
7/F., North Tower, World Finance Centre,  
Harbour City, Canton Road, Tsim Sha Tsui,  
Kowloon, Hong Kong  
Tel: <852> (2) 735 9218  
Fax: <852> (2) 730 0281  
Telex: 40815 HITEC HX

Copyright ' Hitachi, Ltd., 1999. All rights reserved. Printed in Japan.

**HITACHI**



LittleDiode supplies new, hard to find or obsolete electronic components and semiconductors all over the world.

With over two million different components listed you are sure to find the part you need.

Feel free to visit us today at our online store:

[LittleDiode.com](http://LittleDiode.com)

Looking forward to providing you with the best possible service.