

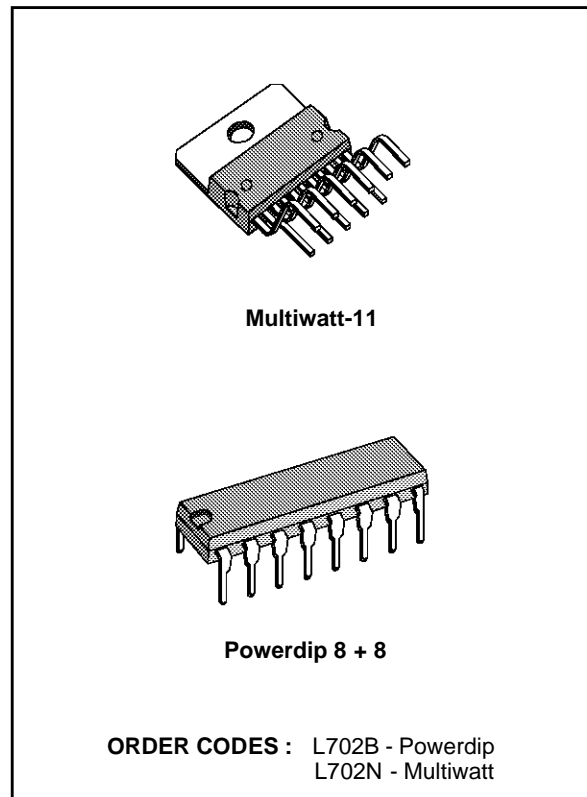
## 2A QUAD DARLINGTON SWITCH

- SUSTAINING VOLTAGE: 70 V
- 2 A OUTPUT
- HIGH CURRENT GAIN
- IDEAL FOR DRIVING SOLENOIDS, DC MOTORS, STEPPER MOTORS, RELAYS, DISPLAYS, ETC.

### DESCRIPTION

The L702 is a monolithic integrated circuit for high current and high voltage switching applications. It comprises four darlington transistors with common emitter and open collector suitable for current sinking applications mounted on the new POWERDIP and Multiwatt® packages.

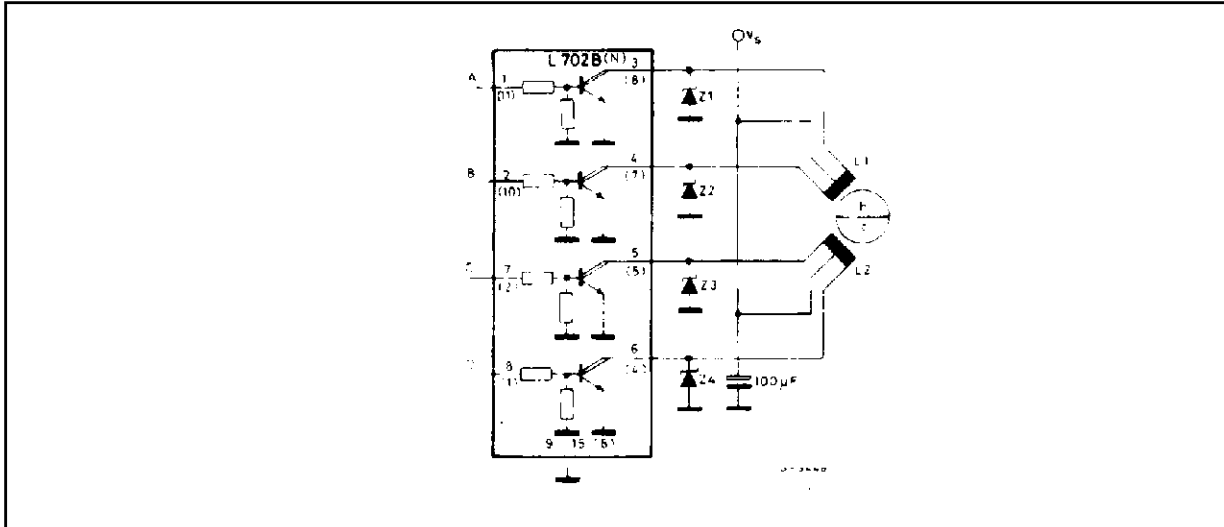
This circuit reduces components, sizes and costs; it can provide direct interface between low level logic and a variety of high current applications.



### ABSOLUTE MAXIMUM RATINGS

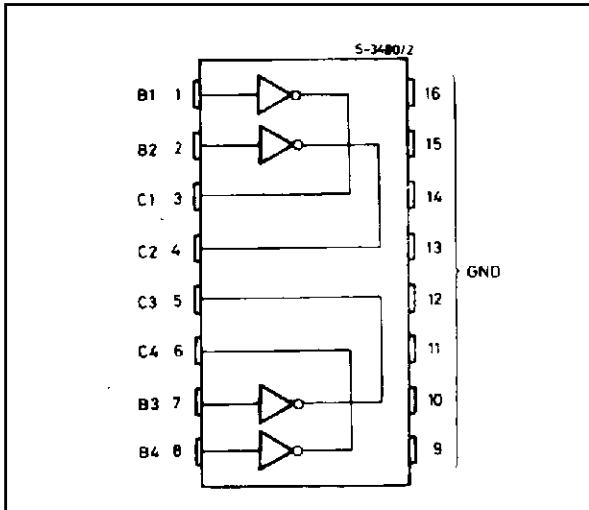
Symbol	Parameter	Value	Unit
$V_{CEX}$	Collector-emitter Voltage (input open)	90	V
$V_i$	Input Voltage	30	V
$I_C$	Collector Current	3	A
$P_{tot}$	Total Power Dissipation at $T_{pin} 9 \text{ to } 16 \leq 90 \text{ }^\circ\text{C}$	4	W
	Total Power Dissipation at $T_{amb} \leq 70 \text{ }^\circ\text{C}$		
	Total Power Dissipation at $T_{case} \leq 90 \text{ }^\circ\text{C}$	20 W	
$T_{stg}$	Storage Temperature	-55 to 150	$^\circ\text{C}$
$T_j$	Operating Junction Temperature	-25 to 150	$^\circ\text{C}$

STEPPING MOTOR BUFFER

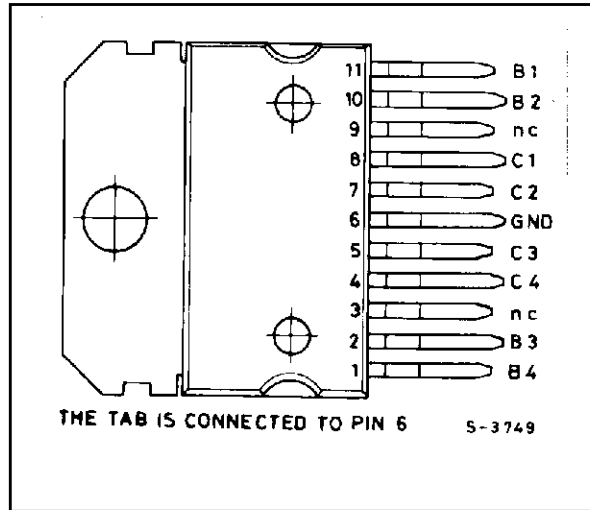


CONNECTION DIAGRAMS (top view)

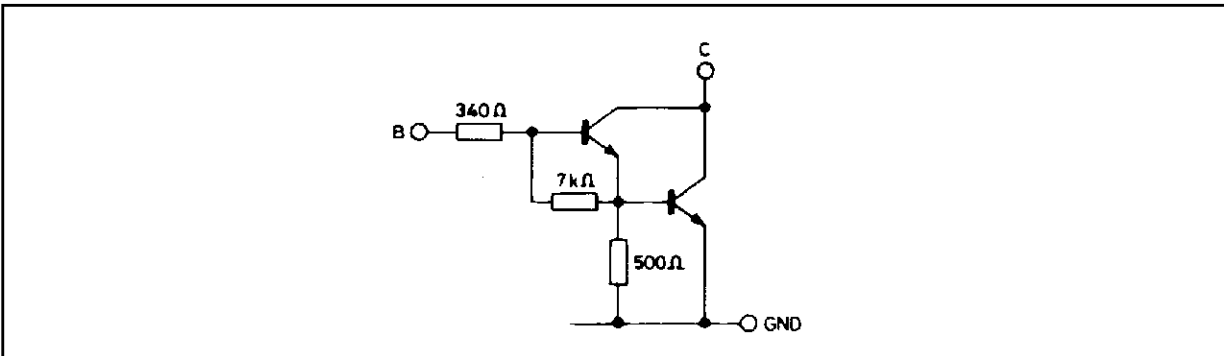
Powerdip



Multiwatt



SCHEMATIC DIAGRAM (each Darlington)



## THERMAL DATA

Symbol	Parameter	Value	Unit		
$R_{th\ j-amb}$	Thermal Resistance Junction Ambient } Powerdip	Max	70	$^{\circ}C/W$	
$R_{th\ j-pins\ 9/16}$	Thermal Resistance Junction Pins 9 to 16	Max	14	$^{\circ}C/W$	
$R_{th\ j-case}$	Thermal Resistance Junction-case	Multiwatt	Max	3	$^{\circ}C/W$

ELECTRICAL CHARACTERISTICS ( $T_{case} = 25^{\circ}C$  unless otherwise specified)

Symbol	Parameter	Test conditions	Min.	Typ.	Max.	Unit	
$I_{CEX}$	Output Leakage Current	$V_{CE} = 90\ V$		10	50	$\mu A$	
$V_{CE(sust)}$	Collector Emitter ( $^{\circ}$ ) Sustaining Voltage	$I_C = 100\ mA$	70			V	
$V_{CE(sat)}$	Collector Emitter Saturation Voltage	$I_C = 1.25\ A$ $I_i = 2\ mA$		1.3	1.9	V	
$h_{FE}$	DC Forward Current Gain	$I_C = 1\ A$ $V_{CE} = 3\ V$	1.000	4.000			
$I_i$	Input Current	$V_i = 3.75\ V$ $V_i = 2.4\ V$ Open Collector		7 3	11 6	mA mA	
$V_i$	Input Voltage	Off Condition	$V_{CE} = 70\ V$			0.4	V
		On Condition	$V_{CE} = 3\ V$	$I_C \geq 1\ A$	2.4		V
$T_{on}$	Turn On Time	$V_s = 12\ V$		0.3		$\mu s$	
$T_{off}$	Turn Off Time	$R_L = 10\ \Omega$		1		$\mu s$	

Figure 1. Switching Time.

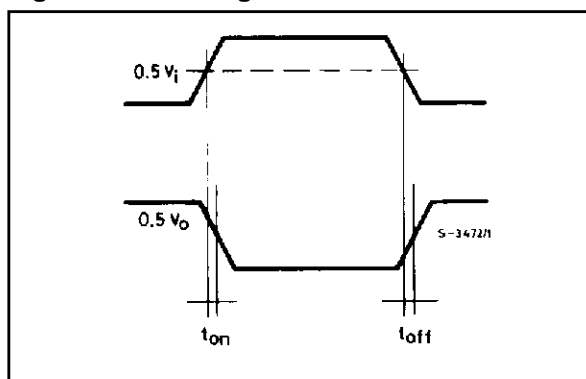
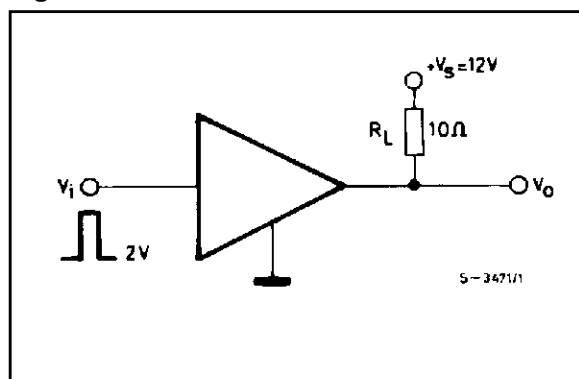
Figure 2.  $t_{on}$  and  $t_{off}$  Test Circuit.

Figure 3. Peak Collector Current vs. Duty Cycle and Number of Outputs (L702B only)

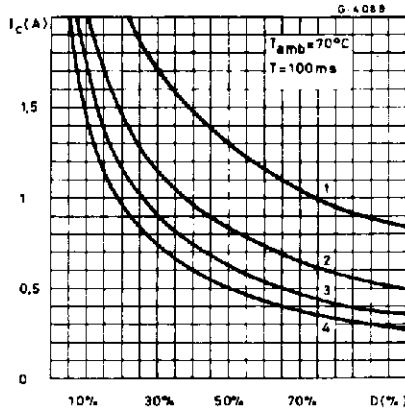


Figure 4. Collector Emitter Saturation Voltage vs. Collector Current.

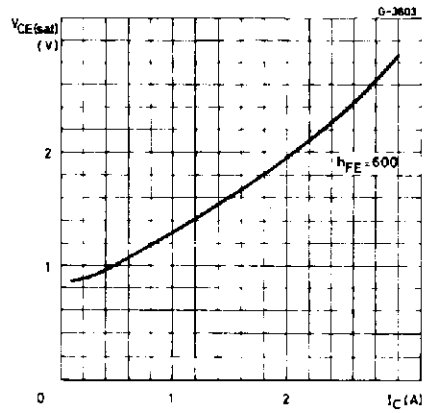


Figure 5. Collector Current vs. Input Voltage.

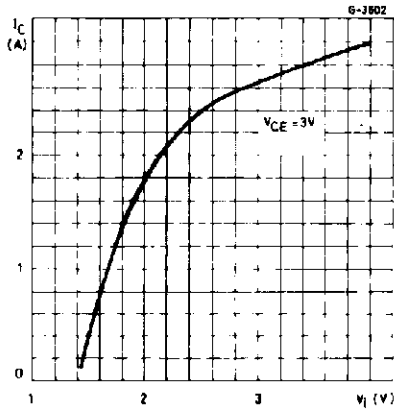


Figure 6. Input Current vs. Input Voltage.

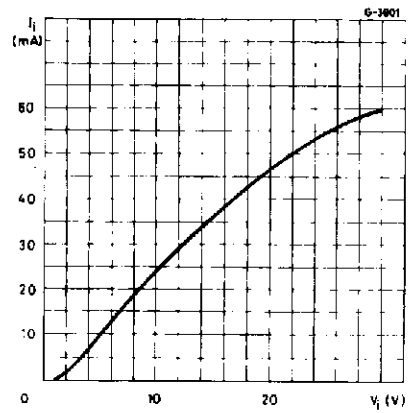


Figure 7. Safe Operating Areas (L702B).

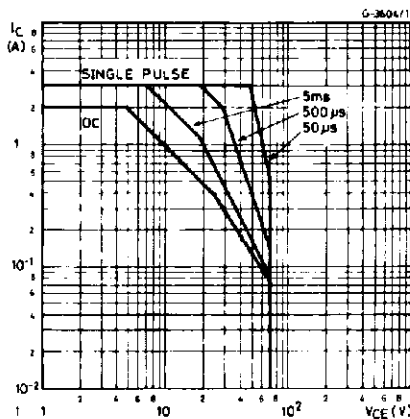
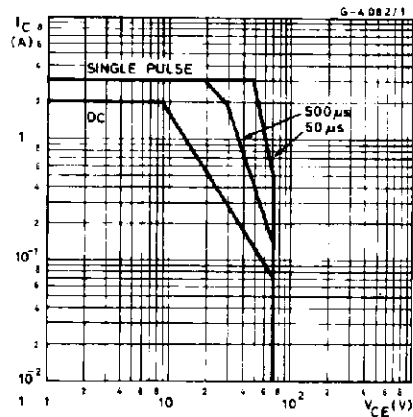
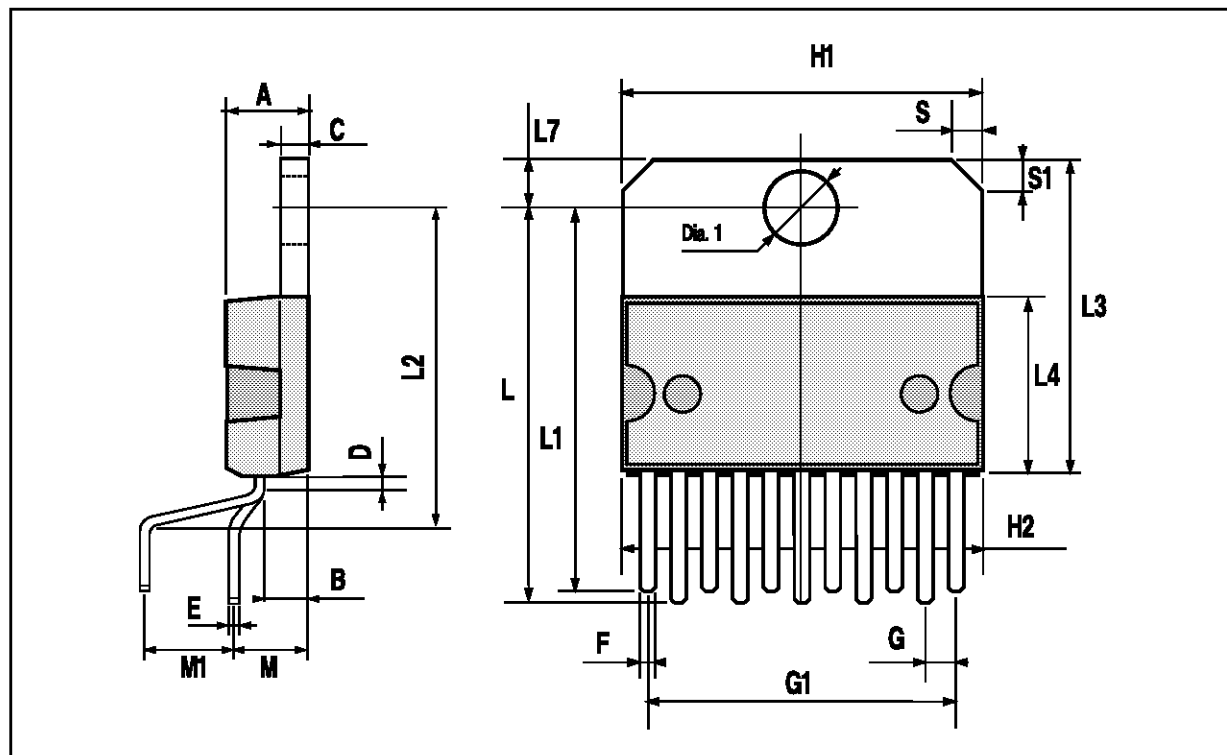


Figure 8. Safe Operating Areas (L702N).



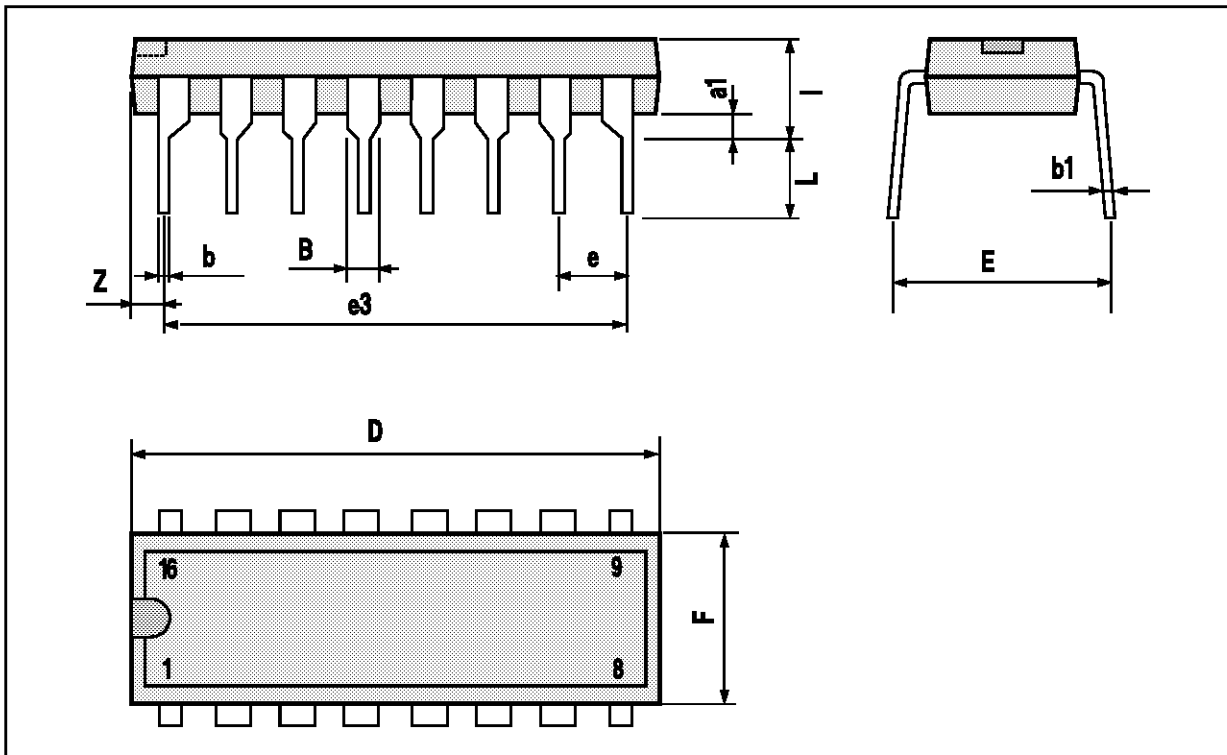
## MULTIWATT11 PACKAGE MECHANICAL DATA

DIM.	mm			inch		
	MIN.	TYP.	MAX.	MIN.	TYP.	MAX.
A			5			0.197
B			2.65			0.104
C			1.6			0.063
D		1			0.039	
E	0.49		0.55	0.019		0.022
F	0.88		0.95	0.035		0.037
G	1.57	1.7	1.83	0.062	0.067	0.072
G1	16.87	17	17.13	0.664	0.669	0.674
H1	19.6			0.772		
H2			20.2			0.795
L	21.5		22.3	0.846		0.878
L1	21.4		22.2	0.843		0.874
L2	17.4		18.1	0.685		0.713
L3	17.25	17.5	17.75	0.679	0.689	0.699
L4	10.3	10.7	10.9	0.406	0.421	0.429
L7	2.65		2.9	0.104		0.114
M	4.1	4.3	4.5	0.161	0.169	0.177
M1	4.88	5.08	5.3	0.192	0.200	0.209
S	1.9		2.6	0.075		0.102
S1	1.9		2.6	0.075		0.102
Dia1	3.65		3.85	0.144		0.152



**POWERDIP PACKAGE MECHANICAL DATA**

DIM.	mm			inch		
	MIN.	TYP.	MAX.	MIN.	TYP.	MAX.
a1	0.51			0.020		
B	0.85		1.40	0.033		0.055
b		0.50			0.020	
b1	0.38		0.50	0.015		0.020
D			20.0			0.787
E		8.80			0.346	
e		2.54			0.100	
e3		17.78			0.700	
F			7.10			0.280
I			5.10			0.201
L		3.30			0.130	
Z			1.27			0.050



Information furnished is believed to be accurate and reliable. However, SGS-THOMSON Microelectronics assumes no responsibility for the consequences of use of such information nor for any infringement of patents or other rights of third parties which may result from its use. No license is granted by implication or otherwise under any patent or patent rights of SGS-THOMSON Microelectronics. Specifications mentioned in this publication are subject to change without notice. This publication supersedes and replaces all information previously supplied. SGS-THOMSON Microelectronics products are not authorized for use as critical components in life support devices or systems without express written approval of SGS-THOMSON Microelectronics.

© 1994 SGS-THOMSON Microelectronics - All Rights Reserved

SGS-THOMSON Microelectronics GROUP OF COMPANIES

Australia - Brazil - France - Germany - Hong Kong - Italy - Japan - Korea - Malaysia - Malta - Morocco - The Netherlands - Singapore - Spain - Sweden - Switzerland - Taiwan - Thailand - United Kingdom - U.S.A.