

HD74LS145 • BCD-to-Decimal Decoders/Drivers (with 15V outputs)

This BCD-to-decimal decoder/driver consists of eight inverters and ten four-input NAND gates. The inverters are connected in pairs to make BCD input data available for decoding by the NAND gates. Full decoding of valid BCD input logic ensures that all outputs remain off for all invalid binary input conditions. This decoder features high-performance, n-p-n output transistors designed for use as indicator/relay drivers or as open-collector logic-circuit drivers.

■ PIN ARRANGEMENT

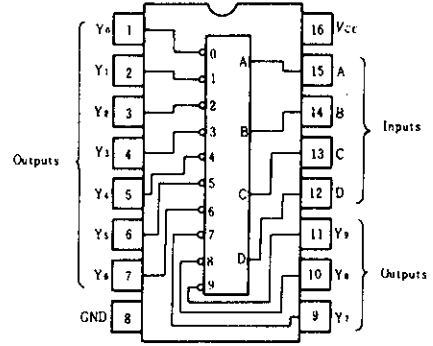

(Top View)

■ BLOCK DIAGRAM

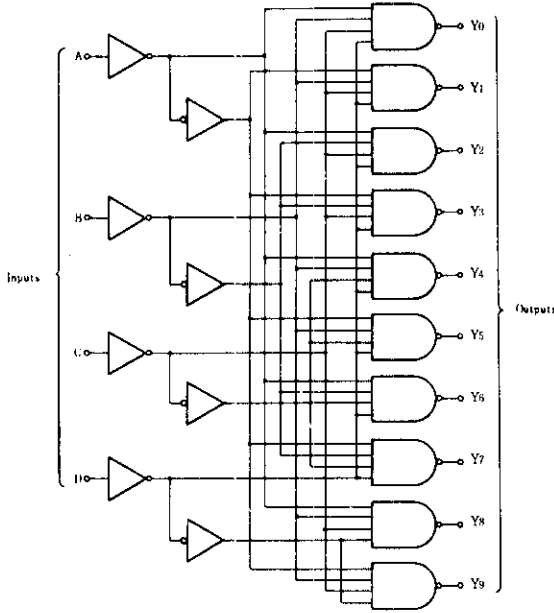

■ FUNCTION TABLE

No.	Inputs				Outputs									
	D	C	B	A	0	1	2	3	4	5	6	7	8	9
0	L	L	L	L	L	H	H	H	H	H	H	H	H	H
1	L	L	L	H	H	L	H	H	H	H	H	H	H	H
2	L	L	H	L	H	H	L	H	H	H	H	H	H	H
3	L	L	H	H	H	H	H	L	H	H	H	H	H	H
4	L	H	L	L	H	H	H	H	L	H	H	H	H	H
5	L	H	L	H	H	H	H	H	H	L	H	H	H	H
6	L	H	H	L	H	H	H	H	H	H	L	H	H	H
7	L	H	H	H	H	H	H	H	H	H	H	L	H	H
8	H	L	L	L	H	H	H	H	H	H	H	H	L	H
9	H	L	L	H	H	H	H	H	H	H	H	H	H	L
INVALID	H	L	H	L	H	H	H	H	H	H	H	H	H	H
	H	L	H	H	H	H	H	H	H	H	H	H	H	H
	H	H	L	L	H	H	H	H	H	H	H	H	H	H
	H	H	L	H	H	H	H	H	H	H	H	H	H	H
	H	H	H	L	H	H	H	H	H	H	H	H	H	H

HD74LS145

RECOMMENDED OPERATING CONDITIONS

Item	Symbol	min	typ	max	Unit
Off-state output voltage	$V_{O(off)}$	—	—	15	V
Low level output current	I_{OL}	—	—	80	mA

ELECTRICAL CHARACTERISTICS ($T_a = -20 \sim +75^\circ\text{C}$)

Item	Symbol	Test Conditions	min	typ*	max	Unit	
Input voltage	V_{IH}		2.0	—	—	V	
	V_{IL}		—	—	0.8	V	
Off-state output current	$I_{O(off)}$	$V_{CC} = 4.75\text{V}$, $V_{IH} = 2\text{V}$, $V_{IL} = 0.8\text{V}$, $V_{O(off)} = 15\text{V}$	—	—	250	μA	
On-state output voltage	$V_{O(on)}$	$V_{CC} = 4.75\text{V}$, $V_{IH} = 2\text{V}$, $V_{IL} = 0.8\text{V}$	$I_{OL} = 12\text{mA}$	—	—	0.4	V
			$I_{OL} = 24\text{mA}$	—	—	0.5	
			$I_{OL} = 80\text{mA}$	—	—	3.0	
Input current	I_{IH}	$V_{CC} = 5.25\text{V}$, $V_I = 2.7\text{V}$	—	—	20	μA	
	I_{IL}	$V_{CC} = 5.25\text{V}$, $V_I = 0.4\text{V}$	—	—	-0.4	mA	
	I_I	$V_{CC} = 5.25\text{V}$, $V_I = 7\text{V}$	—	—	0.1	mA	
Supply current **	I_{CC}	$V_{CC} = 5.25\text{V}$	—	7	13	mA	
Input clamp voltage	V_{IK}	$V_{CC} = 4.75\text{V}$, $I_{IK} = -18\text{mA}$	—	—	-1.5	V	

* $V_{CC} = 5\text{V}$, $T_a = 25^\circ\text{C}$

** I_{CC} is measured with all outputs open and all inputs grounded.

SWITCHING CHARACTERISTICS ($V_{CC} = 5\text{V}$, $T_a = 25^\circ\text{C}$)

Item	Symbol	Test Conditions	min	typ	max	Unit
Propagation delay time	t_{PLH}	$C_L = 45\text{pF}$, $R_L = 665\Omega$	—	—	50	ns
	t_{PHL}		—	—	50	

TESTING METHOD

1) Test Circuit

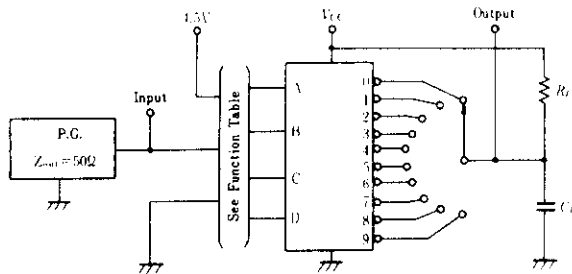

Waveform

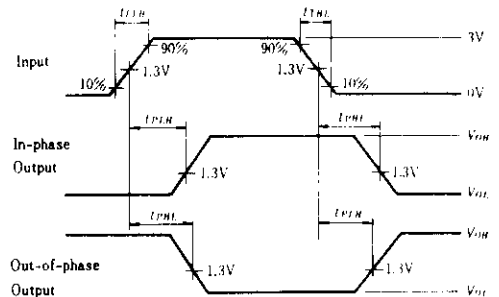

Notes) 1. Input pulse; $t_{TLH} \leq 15\text{ns}$, $t_{THL} \leq 6\text{ns}$, $PRR = 1\text{MHz}$,
duty cycle = 50%

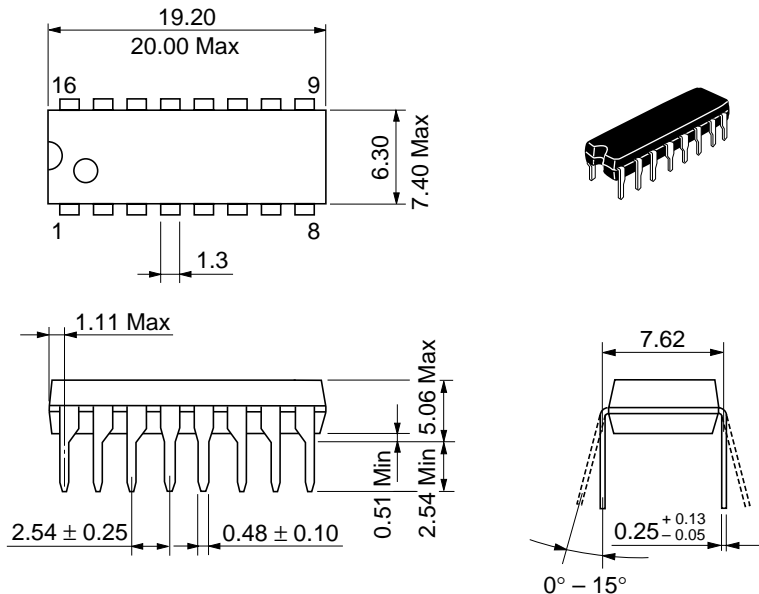

Hitachi Code	DP-16
JEDEC	Conforms
EIAJ	Conforms
Weight (reference value)	1.07 g

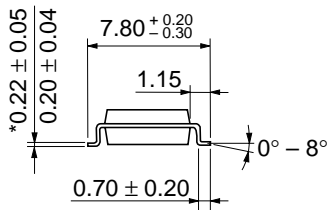
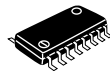
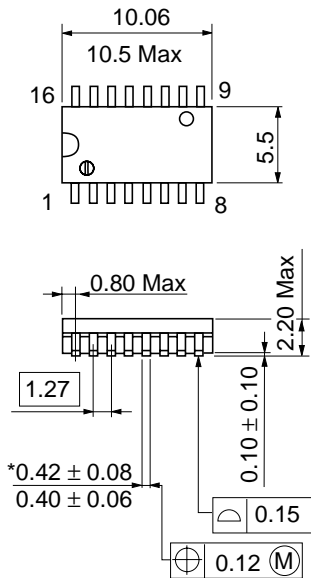

*Dimension including the plating thickness
Base material dimension

Hitachi Code	FP-16DA
JEDEC	—
EIAJ	Conforms
Weight (reference value)	0.24 g

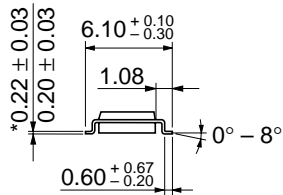
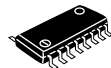
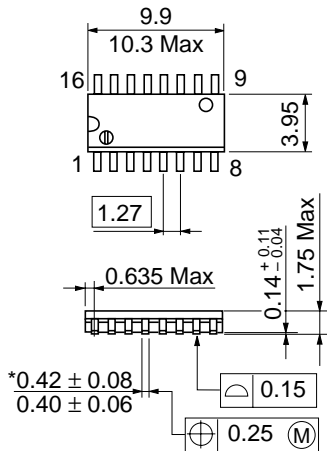

*Dimension including the plating thickness
Base material dimension

Hitachi Code	FP-16DN
JEDEC	Conforms
EIAJ	Conforms
Weight (reference value)	0.15 g

Cautions

1. Hitachi neither warrants nor grants licenses of any rights of Hitachi's or any third party's patent, copyright, trademark, or other intellectual property rights for information contained in this document. Hitachi bears no responsibility for problems that may arise with third party's rights, including intellectual property rights, in connection with use of the information contained in this document.
2. Products and product specifications may be subject to change without notice. Confirm that you have received the latest product standards or specifications before final design, purchase or use.
3. Hitachi makes every attempt to ensure that its products are of high quality and reliability. However, contact Hitachi's sales office before using the product in an application that demands especially high quality and reliability or where its failure or malfunction may directly threaten human life or cause risk of bodily injury, such as aerospace, aeronautics, nuclear power, combustion control, transportation, traffic, safety equipment or medical equipment for life support.
4. Design your application so that the product is used within the ranges guaranteed by Hitachi particularly for maximum rating, operating supply voltage range, heat radiation characteristics, installation conditions and other characteristics. Hitachi bears no responsibility for failure or damage when used beyond the guaranteed ranges. Even within the guaranteed ranges, consider normally foreseeable failure rates or failure modes in semiconductor devices and employ systemic measures such as fail-safes, so that the equipment incorporating Hitachi product does not cause bodily injury, fire or other consequential damage due to operation of the Hitachi product.
5. This product is not designed to be radiation resistant.
6. No one is permitted to reproduce or duplicate, in any form, the whole or part of this document without written approval from Hitachi.
7. Contact Hitachi's sales office for any questions regarding this document or Hitachi semiconductor products.

HITACHI

Hitachi, Ltd.

Semiconductor & Integrated Circuits.
Nippon Bldg., 2-6-2, Ohte-machi, Chiyoda-ku, Tokyo 100-0004, Japan
Tel: Tokyo (03) 3270-2111 Fax: (03) 3270-5109

URL North America : <http://semiconductor.hitachi.com/>
 Europe : <http://www.hitachi-eu.com/hel/ecg>
 Asia (Singapore) : <http://www.has.hitachi.com.sg/grp3/sicd/index.htm>
 Asia (Taiwan) : http://www.hitachi.com.tw/E/Product/SICD_Frame.htm
 Asia (HongKong) : <http://www.hitachi.com.hk/eng/bo/grp3/index.htm>
 Japan : <http://www.hitachi.co.jp/Sicd/indx.htm>

For further information write to:

Hitachi Semiconductor
(America) Inc.
179 East Tasman Drive,
San Jose, CA 95134
Tel: <1> (408) 433-1990
Fax: <1>(408) 433-0223

Hitachi Europe GmbH
Electronic components Group
Dornacher Straße 3
D-85622 Feldkirchen, Munich
Germany
Tel: <49> (89) 9 9180-0
Fax: <49> (89) 9 29 30 00

Hitachi Europe Ltd.
Electronic Components Group.
Whitebrook Park
Lower Cookham Road
Maidenhead
Berkshire SL6 8YA, United Kingdom
Tel: <44> (1628) 585000
Fax: <44> (1628) 778322

Hitachi Asia Pte. Ltd.
16 Collyer Quay #20-00
Hitachi Tower
Singapore 049318
Tel: 535-2100
Fax: 535-1533

Hitachi Asia Ltd.
Taipei Branch Office
3F, Hung Kuo Building, No.167,
Tun-Hwa North Road, Taipei (105)
Tel: <886> (2) 2718-3666
Fax: <886> (2) 2718-8180

Hitachi Asia (Hong Kong) Ltd.
Group III (Electronic Components)
7/F., North Tower, World Finance Centre,
Harbour City, Canton Road, Tsim Sha Tsui,
Kowloon, Hong Kong
Tel: <852> (2) 735 9218
Fax: <852> (2) 730 0281
Telex: 40815 HITEC HX

Copyright ' Hitachi, Ltd., 1999. All rights reserved. Printed in Japan.

HITACHI

This datasheet has been downloaded from:

www.DatasheetCatalog.com

Datasheets for electronic components.



LittleDiode supplies new, hard to find or obsolete electronic components and semiconductors all over the world.

With over two million different components listed you are sure to find the part you need.

Feel free to visit us today at our online store:

LittleDiode.com

Looking forward to providing you with the best possible service.