

LOW-NOISE VERTICAL DEFLECTION SYSTEM

- COMPLETE VERTICAL DEFLECTION SYSTEM
- LOW NOISE
- SUITABLE FOR HIGH DEFINITION MONITORS
- ESD PROTECTED

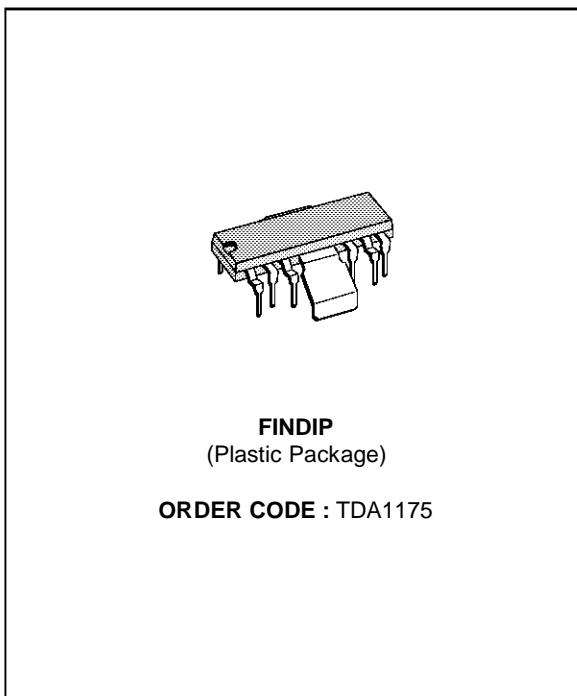

DESCRIPTION

The TDA1175 is a monolithic integrated circuit in FINDIP plastic package. It is intended for use in black and white and colour TV receivers. Low-noise makes this device particularly suitable for use in monitors. The functions incorporated are : synchronization circuit, oscillator and ramp generator, high power gain amplifier, flyback generator, voltage regulator.

PIN CONNECTIONS

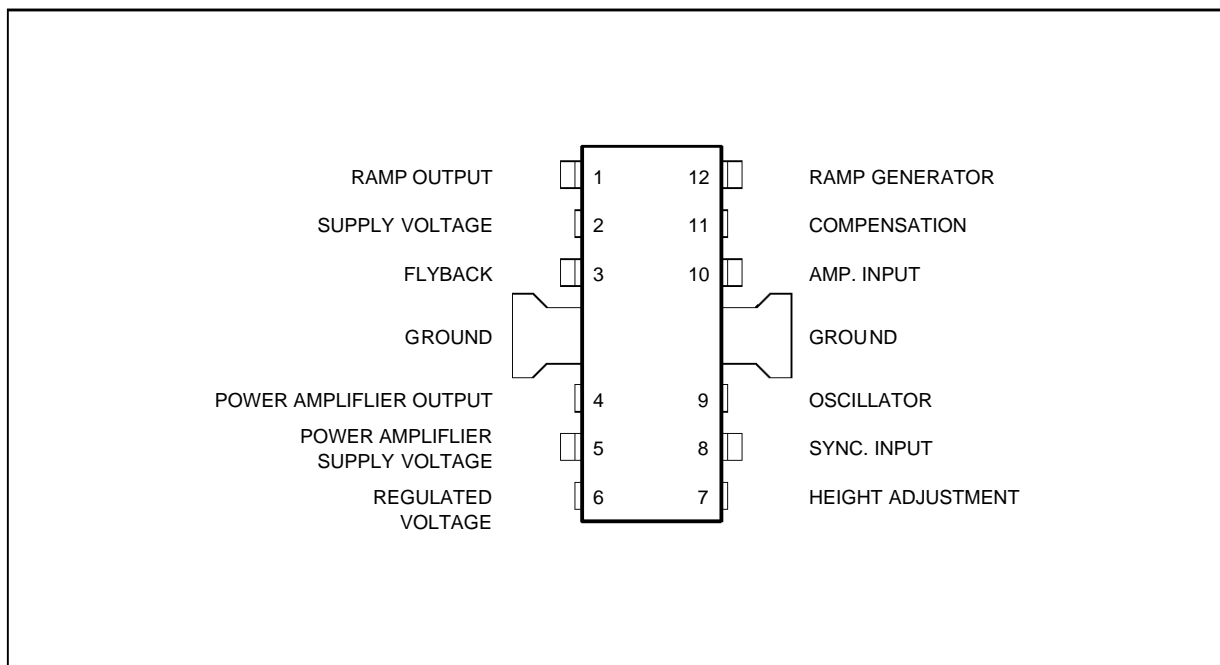

1175-01.EPS

BLOCK DIAGRAM

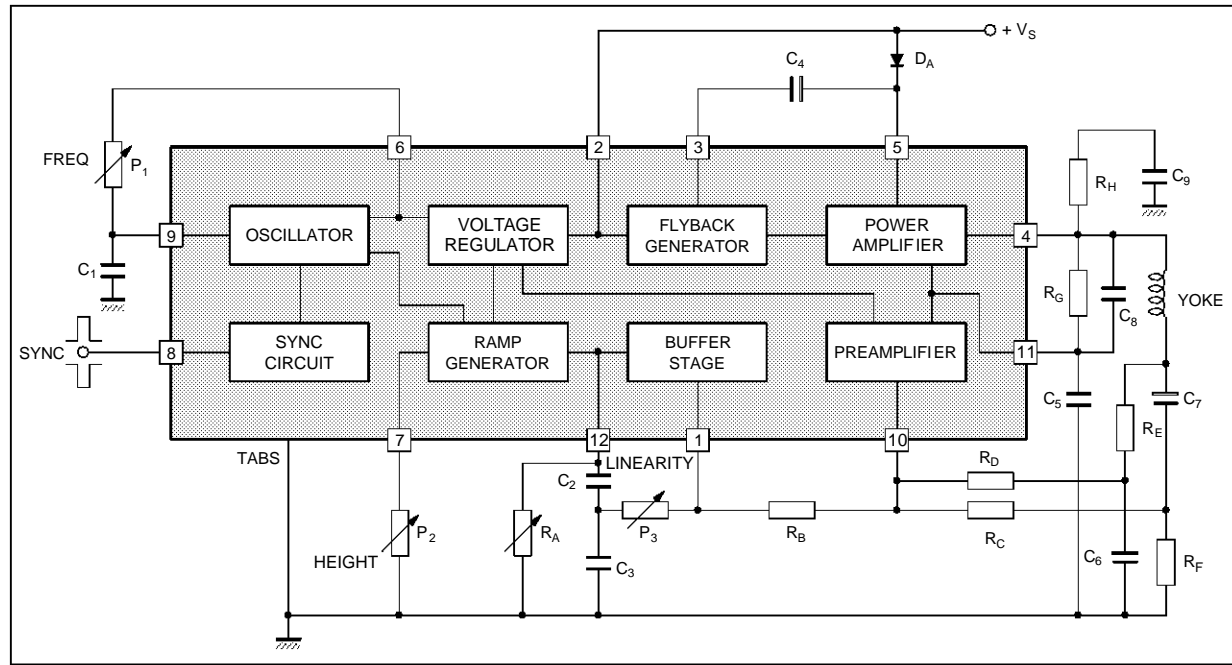

ABSOLUTE MAXIMUM RATINGS

Symbol	Parameter	Value	Unit
V_s	Supply Voltage at Pin 2	35	V
V_4, V_5	Flyback Peak Voltage	60	V
V_{10}	Power Amplifier Input Voltage	+ 10 - 0.5	V
I_o	Output Peak Current (non repetitive) at $t = 2ms$	2	A
I_o	Output Peak Current at $f = 50Hz, t \leq 10\mu s$	2.5	A
I_o	Output Peak Current at $f = 50Hz, t > 10\mu s$	1.5	A
I_3	Pin 3 DC Current at $V_4 < V_2$	100	mA
I_3	Pin 3 Peak to Peak Flyback Current for $f = 50Hz, t_{fly} \leq 1.5ms$	1.8	A
I_8	Pin 8 Current	± 20	mA
P_{tot}	Power Dissipation : at $T_{tab} = 90^\circ C$ at $T_{amb} = 80^\circ C$ (free air)	5 1	W
T_{stg}, T_j	Storage and Junction Temperature	- 40, + 150	$^\circ C$

THERMAL DATA

Symbol	Parameter	Value	Unit
$R_{th(j-tab)}$	Thermal Resistance Junction-tab	Max. 12	$^\circ C/W$
$R_{th(j-amb)}$	Thermal Resistance Junction-ambient	Max. 70	$^\circ C/W(1)$

(1) Obtained with tabs soldered to printed circuit with minimized copper area.

ELECTRICAL CHARACTERISTICS ($T_{amb} = 25\text{ }^{\circ}\text{C}$, unless otherwise specified)

Symbol	Parameter	Test Conditions	Min.	Typ.	Max.	Unit	Fig.
DC CHARACTERISTICS (Refer to the test circuits, $V_S = 35\text{V}$)							
I_2	Pin 2 Quiescent Current	$I_3 = 0$		7	14	mA	1b
I_5	Pin 5 Quiescent Current	$I_4 = 0$		8	17	mA	1b
$-I_9$	Oscillator Bias Current	$V_9 = 1\text{V}$		0.1	1	μA	1a
$-I_{10}$	Amplifier Input Bias Current	$V_{10} = 1\text{V}$		1	10	μA	1b
$-I_{12}$	Ramp Generator Bias Current	$V_{12} = 0$		0.02	0.3	μA	1a
$-I_{12}$	Ramp Generator Current	$I_7 = 20\mu\text{A}$, $V_{12} = 0$	18.5	20	21.5	μA	1b
$\frac{\Delta I_{12}}{I_{12}}$	Ramp Generator Non-linearity	$\Delta V_{12} = 0$ to 12V , $I_7 = 20\mu\text{A}$		0.2	1	%	1b
V_S	Supply Voltage Range		10		35	V	
V_1	Pin 1 Saturation Voltage to Ground	$I_1 = 1\text{mA}$		1	1.4	V	
V_3	Pin 3 Saturation Voltage to Ground	$I_3 = 10\text{mA}$		1.5	2.5	V	1a
V_4	Quiescent output Voltage	$V_S = 10\text{V}$, $R_1 = 1\text{k}\Omega$, $R_2 = 1\text{k}\Omega$ $V_S = 35\text{V}$, $R_1 = 3\text{k}\Omega$, $R_2 = 1\text{k}\Omega$	4.1 8.2	4.4 8.8	4.7 9.4	V V	1a 1a
V_{4L}	Output Saturation Voltage to Ground	$-I_4 = 0.1\text{A}$ $-I_4 = 0.8\text{A}$		0.9 1.8	1.2 2.2	V v	1c 1c
V_{4H}	Output Saturation Voltage to Supply	$I_4 = 0.1\text{A}$ $I_4 = 0.8\text{A}$		1.4 2.8	2.1 3.1	V V	1d 1d
V_6	Regulated Voltage at Pin 6		6.5	6.7	6.9	V	1b
V_7	Regulated Voltage at Pin 7	$I_7 = 20\mu\text{A}$	6.6	6.8	7	V	1b
$\frac{ \Delta V_6 }{\Delta V_S}$, $\frac{ \Delta V_7 }{\Delta V_S}$	Regulated Voltage Drift with Supply Voltage	$\Delta V_S = 10$ to 35V		1	2	mV/V	1b
V_{10}	Amplifier Input Reference Voltage	$V_8 \leq 0.4\text{V}$	2.20	2.27	2.35	V	

AC CHARACTERISTICS (Refer to the AC test circuit, $V_S = 22\text{V}$, $f = 50\text{Hz}$)

I_S	Supply Current	$I_y = 1\text{A}_{PP}$		140		mA	2
I_8	Sync. Input Current (positive or negative)		0.5		2	mA	2
V_4	Flyback Voltage	$I_y = 1\text{A}_{PP}$		45		V	2
t_{fly}	Flyback Time	$I_y = 1\text{A}_{PP}$		0.7		ms	2
V_{ON}	Peak to Peak Output Noise	Pin 9 Connected to GND		18	30	mVpp	2
f_o	Free Running Frequency	$(P_1 + R_1) = 300\text{k}\Omega$ $C_9 = 0.1\mu\text{F}$	36	43.5		Hz	2
f_{OPER}	Operating Frequency Range		10		120	Hz	2
Δf	Synchronization Range	$I_8 = 0.5\text{mA}$, $C_9 = 0.1\mu\text{F}$ $(P_1 + R_1) = 300\text{k}\Omega$	14			Hz	2
$\frac{\Delta f}{\Delta V_S}$	Frequency Drift with Supply Voltage	$V_S = 10$ to 35V		0.005		Hz/V	2
$\frac{ \Delta f }{\Delta T_{ab}}$	Frequency Drift with tab Temperature	$T_{tab} = 40$ to 120°C		0.01		Hz/ $^{\circ}\text{C}$	2

1175-03.TEL

TDA1175

Figure 1 : DC Test Circuits

Figure 1a

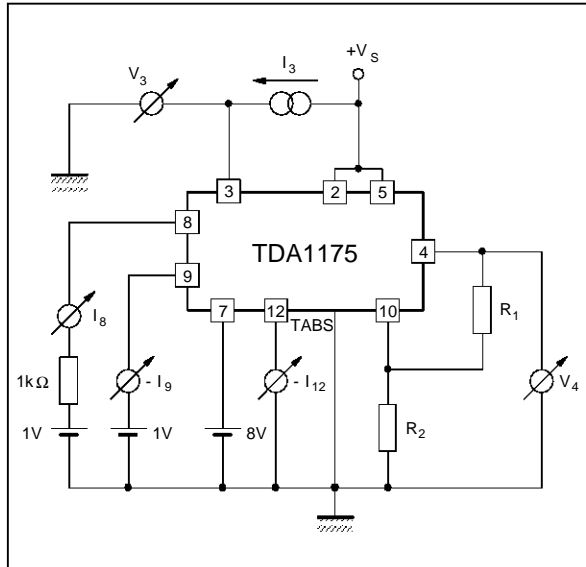

Figure 1b

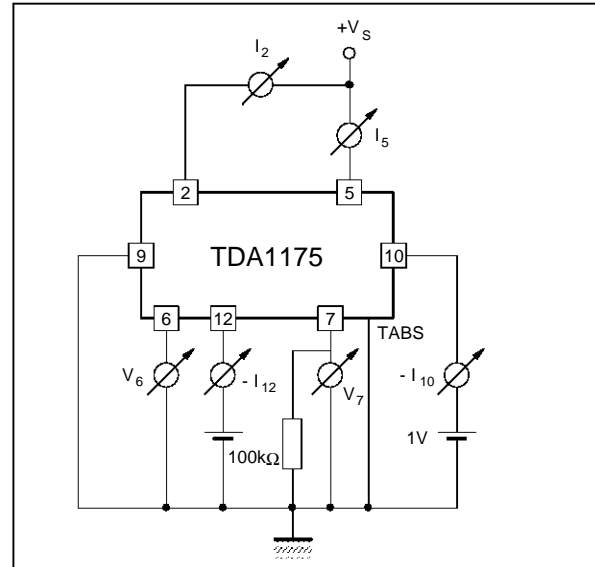

Figure 1c

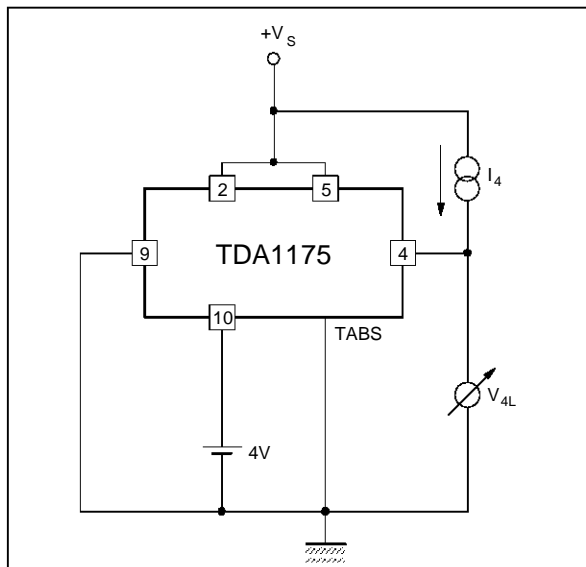

Figure 1d

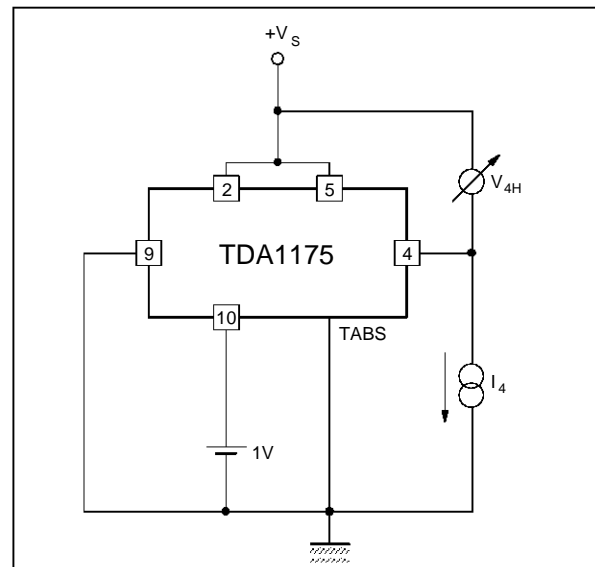
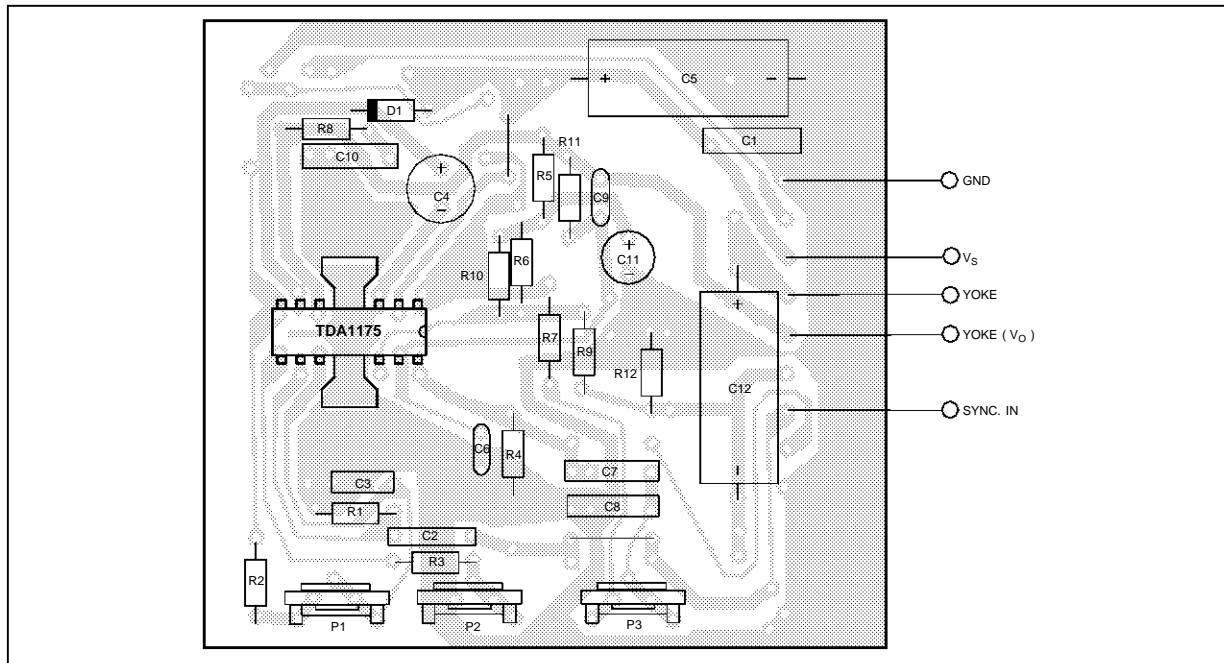

Figure 4 : P.C. Board and Components Layout of the Circuit of Figure 3 (1:1 scale)



1175-09.EPS

MOUNTING INSTRUCTION

During soldering the tab temperature must not exceed 260°C and the soldering time must not be longer than 12 seconds.

The external heatsink or printed circuit copper area must be connected to electrical ground.

The junction to ambient thermal resistance can be

reduced by soldering the tabs to a suitable copper area of the printed circuit board (Figure 5) or to an external heatsink (Figure 6).

The diagram of Figure 7 shows the maximum dissipable power P_{tot} and the $R_{th j-amb}$ as a function of the side "e" of two equal square copper areas having a thickness of 35 μ (1.4 mil).

Figure 5 : Example of P.C. Board Copper Area Used as Heatsink

Figure 6 : Example of External Heatsink

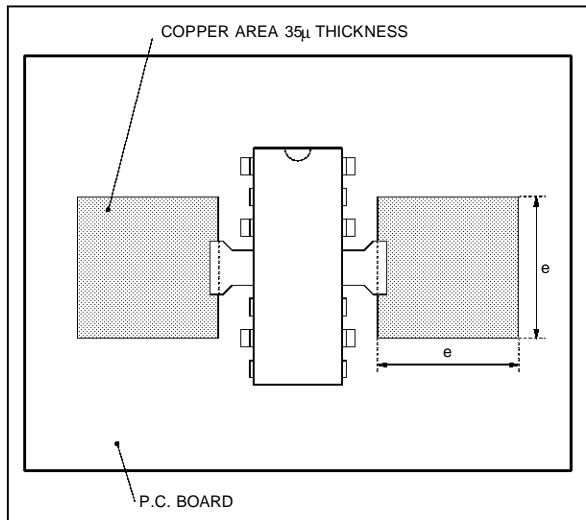

1175-10.EPS

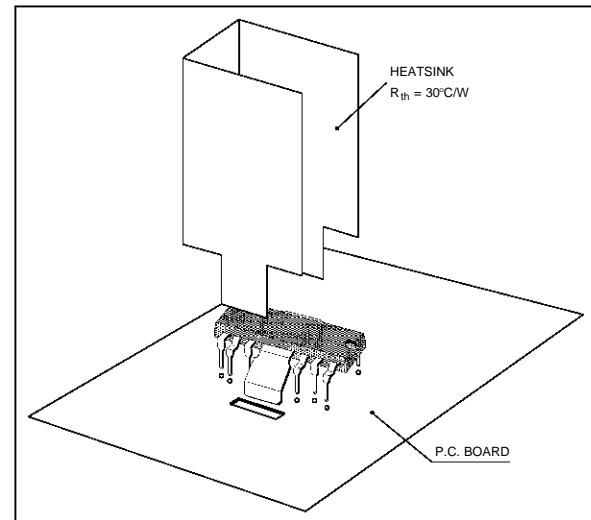

1175-11.EPS

Figure 7 : Maximum Power Dissipation and Junction-ambient Thermal Resistance versus "e"

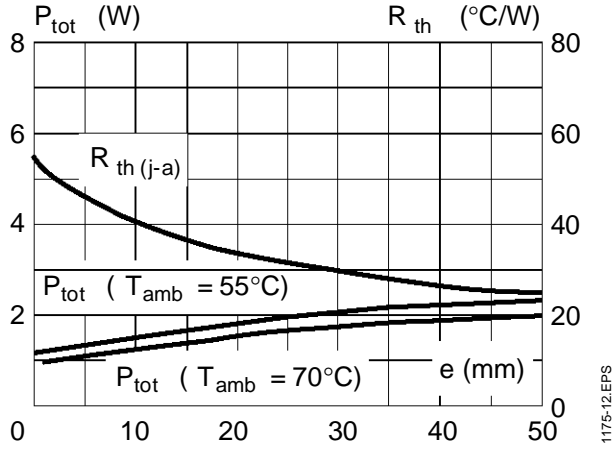
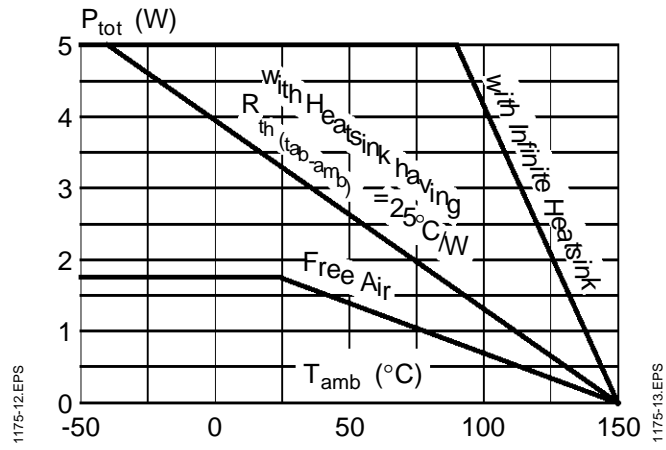
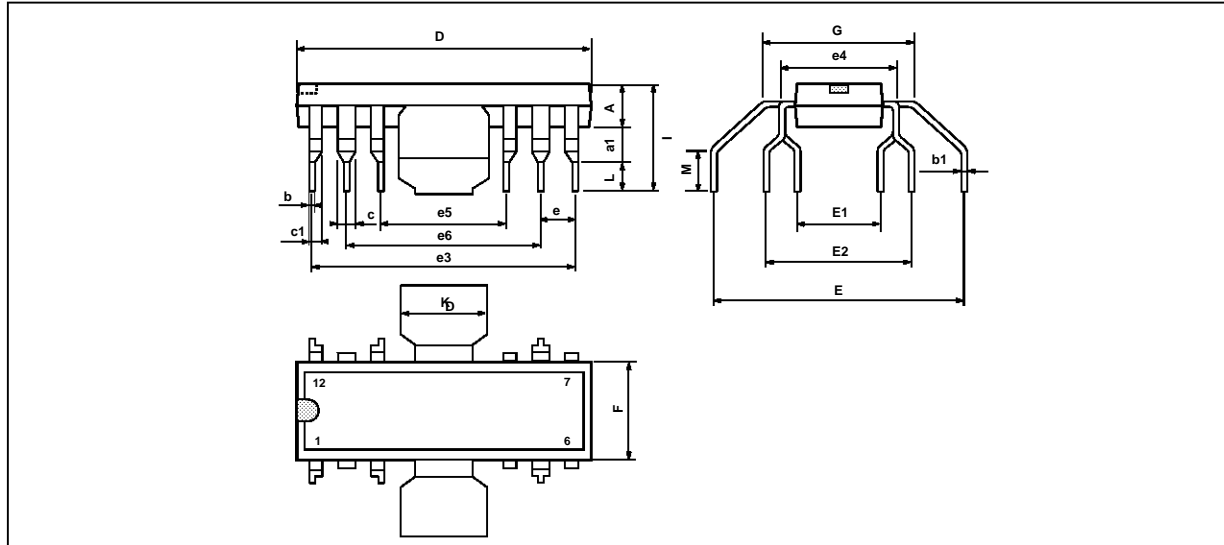

Figure 8 : Maximum Allowable Power Dissipation versus Ambient Temperature



PACKAGE MECHANICAL DATA : 12 PINS - PLASTIC FINDIP



PIM-FDIP.EPS

Dimensions	Millimeters			Inches		
	Min.	Typ.	Max.	Min.	Typ.	Max.
A	3.8		4.05	0.150		0.159
a1	1.5		1.75	0.059		0.069
b	0.55		0.6	0.022		0.024
b1	0.3		0.35	0.012		0.014
c		1.32			0.052	
c1		0.94			0.037	
D	19.2		19.9	0.756		0.783
E	16.8	17.2	17.6	0.661	0.677	0.693
E1	4.86		5.56	0.191		0.219
E2	10.11		10.81	0.398		0.426
e	2.29	2.54	2.79	0.090	0.100	0.110
e3	17.43	17.78	18.13	0.686	0.700	0.714
e4		7.62			0.300	
e5	7.27	7.62	7.97	0.286	0.300	0.314
e6	12.35	12.7	13.05	0.486	0.500	0.514
F	6.3		7.1	0.248		0.280
G		9.8			0.386	
I	7.8		8.6	0.307		0.339
K	6.1		6.5	0.240		0.256
L	2.5		2.9	0.098		0.114
M	2.5		3.1	0.098		

FINDIP.TBL

Information furnished is believed to be accurate and reliable. However, SGS-THOMSON Microelectronics assumes no responsibility for the consequences of use of such information nor for any infringement of patents or other rights of third parties which may result from its use. No licence is granted by implication or otherwise under any patent or patent rights of SGS-THOMSON Microelectronics. Specifications mentioned in this publication are subject to change without notice. This publication supersedes and replaces all information previously supplied. SGS-THOMSON Microelectronics products are not authorized for use as critical components in life support devices or systems without express written approval of SGS-THOMSON Microelectronics.

© 1994 SGS-THOMSON Microelectronics - All Rights Reserved

Purchase of I²C Components of SGS-THOMSON Microelectronics, conveys a license under the Philips I²C Patent. Rights to use these components in a I²C system, is granted provided that the system conforms to the I²C Standard Specifications as defined by Philips.

SGS-THOMSON Microelectronics GROUP OF COMPANIES

Australia - Brazil - China - France - Germany - Hong Kong - Italy - Japan - Korea - Malaysia - Malta - Morocco
The Netherlands - Singapore - Spain - Sweden - Switzerland - Taiwan - Thailand - United Kingdom - U.S.A.