

# Agilent HDMP-0480 Octal Cell Port Bypass Circuit without Clock and Data Recovery Data Sheet

## Description

The HDMP-0480 is an Octal Cell Port Bypass Circuit (PBC). This device minimizes part count, cost and jitter accumulation. Port Bypass Circuits are used in hard disk arrays constructed in Fibre Channel Arbitrated Loop (FC-AL) configurations. By using Port Bypass Circuits, hard disks may be pulled out or swapped while other disks in the array are available to the system.

A Port Bypass Circuit (PBC) consists of multiple 2:1 multiplexers daisy chained along with a CDR. Each port has two modes of operation: “disk in loop” and “disk by-passed”. When the “disk in loop” mode is selected, the loop goes into and out of the disk drive at that port. For example, data goes from the HDMP-0480’s TO\_NODE[n]± differential output pins to the Disk Drive Transceiver IC’s (e.g. an HDMP-1636A) Rx± differential input pins. Data from the Disk Drive Transceiver IC’s

Tx± differential outputs goes to the HDMP- 0480’s FM\_NODE[n]± differential input pins. When the “disk bypassed” mode is selected, the disk drive is either absent or non-functional and the loop bypasses the hard disk.

The “disk bypassed” mode is enabled by pulling the BYPASS[n]- pin low. Leave BYPASS[n]- floating to enable the “disk in loop” mode. HDMP-0480’s may be cascaded with other members of the HDMP-04XX/HDMP-05XX family through the FM\_NODE and TO\_NODE pins to accommodate any number of hard disks. The unused cells in this PBC may be bypassed by using pulldown resistors on the BYPASS[n]- pins for these cells.

An HDMP-0480 may also be used as eight 1:1 buffers. In addition, an HDMP-0480 may be configured as four 2:1 multiplexers or as four 1:2 buffers.

## Features

- Supports 1.0625 Gb/s fibre channel operation
- Supports 1.25 Gb/s gigabit Ethernet (GE) operation
- Octal cell PBC in one package
- Valid amplitude detection on FM\_NODE[7] input
- Equalizers on all inputs
- High speed LVPECL I/O
- Buffered Line Logic (BLL) outputs (no external bias resistors required)
- 0.76 W typical power at Vcc = 3.3V
- 64 Pin, 10 mm, low cost plastic QFP package

## Applications

- RAID, JBOD, BTS cabinets
- Four 2:1 muxes
- Four 1:2 buffers
- 1 = > N gigabit serial buffer
- N = > 1 gigabit serial mux

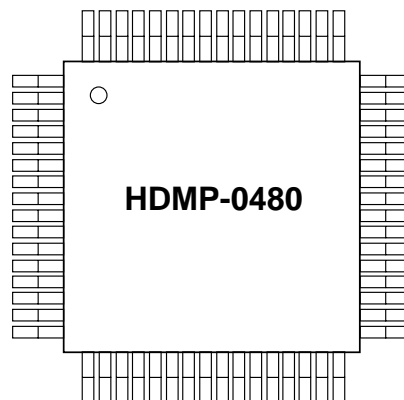

*CAUTION: As with all semiconductor ICs, it is advised that normal static precautions be taken in the handling and assembly of this component to prevent damage and/or degradation which may be induced by electrostatic discharge (ESD).*



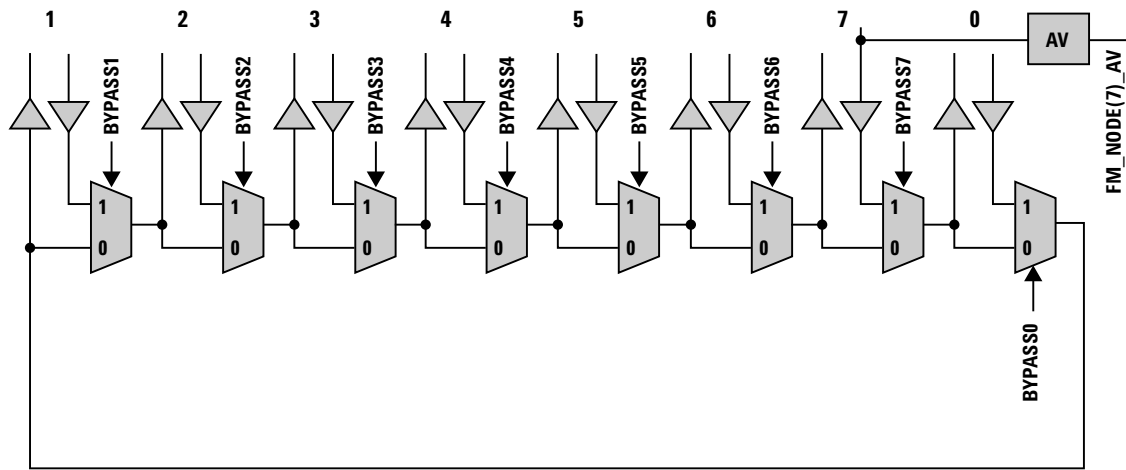

Figure 1. Block Diagram of HDMP-0480.

### HDMP-0480 Block Diagram

#### AV Output

The Amplitude Valid (AV) block detects if the incoming data on  $FM\_NODE[7]_{\pm}$  is valid by examining the differential amplitude of that input. The incoming data is considered valid, and  $FM\_NODE[7]_{AV}$  is driven high, as long as the amplitude is greater than 400 mV (differential peak-to-peak).  $FM\_NODE[7]_{AV}$  is driven low as long as the amplitude of the input signal is less than 100 mV (differential peak-to-peak). When the amplitude of the input signal is between 100-400 mV (differential peak-to-peak),  $FM\_NODE[7]_{AV}$  is unpredictable.

#### BLL Output

All  $TO\_NODE[n]_{\pm}$  high-speed differential outputs are driven by a Buffered Line Logic (BLL) circuit that has on-chip source termination, so no external bias resistors are required. The BLL Outputs on the HDMP-0480 are of equal strength and can drive in excess of 120 inches of FR-4 PCB trace. Unused outputs should not be left unconnected. Ideally, unused outputs should have their differential pins shorted together with a short PCB trace. If transmission lines are connected to the output pins, the lines should be differentially terminated with an appropriate resistor. The value of the termination resistor should match the PCB trace differential impedance.

#### EQU Input

All  $FM\_NODE[n]_{\pm}$  high-speed differential inputs have an Equalization (EQU) buffer to offset the effects of skin loss and dispersion on PCBs. An external termination resistor is required across all high-speed inputs.

#### BYPASS[N]- Input

The active low  $BYPASS[n]_{-}$  inputs control the data flow through the HDMP-0480. All  $BYPASS$  pins are LVTTTL and contain internal pull-up circuitry. To bypass a port, the appropriate  $BYPASS[n]_{-}$  pin should be connected to GND through a  $1k\Omega$  resistor. Otherwise, the  $BYPASS[n]_{-}$  inputs should be left to float. In this case, the internal pull-up circuitry will force them high.

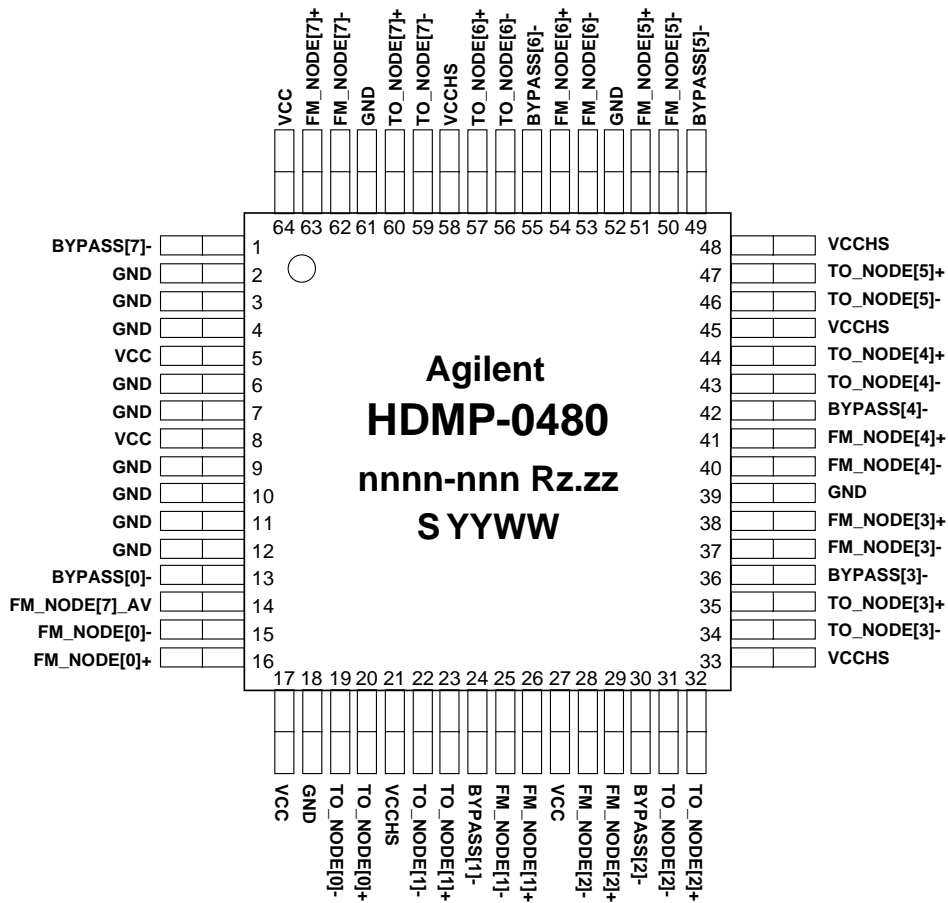

**Figure 2. HDMP-0480 Package Layout and Marking, Top View.**

nnnn-nnn = wafer lot - build number; Rz.zz = Die Revision; S = Supplier Code; YYWW = Date Code (YY = year, WW = work week); COUNTRY = country of manufacture (on back side).

### I/O Type Definitions

I/O Type	Definition
I-LVTTL	LVTTL Input
O-LVTTL	LVTTL Output
HS_OUT	High Speed Output, LVPECL Compatible
HS_IN	High Speed Input
C	External circuit node
S	Power supply or ground

**Table 1. Pin Definitions for HDMP-0480.**

Pin Name	Pin	Pin Type	Pin Description
TO_NODE[0]+	20	HS_OUT	<b>Serial Data Outputs:</b> High-speed outputs to a hard disk drive or to a cable input.
TO_NODE[0]-	19		
TO_NODE[1]+	23		
TO_NODE[1]-	22		
TO_NODE[2]+	32		
TO_NODE[2]-	31		
TO_NODE[3]+	35		
TO_NODE[3]-	34		
TO_NODE[4]+	44		
TO_NODE[4]-	43		
TO_NODE[5]+	47		
TO_NODE[5]-	46		
TO_NODE[6]+	57		
TO_NODE[6]-	56		
TO_NODE[7]+	60	HS_IN	<b>Serial Data Inputs:</b> High-speed inputs from a hard disk drive or from a cable output.
TO_NODE[7]-	59		
FM_NODE[0]+	16		
FM_NODE[0]-	15		
FM_NODE[1]+	26		
FM_NODE[1]-	25		
FM_NODE[2]+	29		
FM_NODE[2]-	28		
FM_NODE[3]+	38		
FM_NODE[3]-	37		
FM_NODE[4]+	41		
FM_NODE[4]-	40		
FM_NODE[5]+	51		
FM_NODE[5]-	50		
FM_NODE[6]+	54		
FM_NODE[6]-	53		
FM_NODE[7]+	63	I-LVTTL	<b>Bypass Inputs:</b> For “disk bypassed” mode, connect BYPASS[n]- to GND through a 1k resistor. For “disk in loop” mode, float HIGH.
FM_NODE[7]-	62		
BYPASS[0]-	13		
BYPASS[1]-	24		
BYPASS[2]-	30		
BYPASS[3]-	36		
BYPASS[4]-	42		
BYPASS[5]-	49		
BYPASS[6]-	55	O-LVTTL	<b>Amplitude Valid:</b> Indicates acceptable signal amplitude on the FM_NODE[7] $\pm$ inputs. If (FM_NODE[7] <sub>+</sub> - FM_NODE[7] <sub>-</sub> ) >= 400 mV peak-to-peak, FM_NODE[7] <sub>AV</sub> = 1 If 400 mV > (FM_NODE[7] <sub>+</sub> - FM_NODE[7] <sub>-</sub> ) > 100 mV, FM_NODE[7] <sub>AV</sub> = unpredictable If 100 mV >= (FM_NODE[7] <sub>+</sub> - FM_NODE[7] <sub>-</sub> ), FM_NODE[7] <sub>AV</sub> = 0
BYPASS[7]-	1		
FM_NODE[7] <sub>AV</sub>	14		

Table 1 is continued on next page.

**Table 1. Pin Definitions for HDMP-0480, continued**

Pin Name	Pin	Pin Type	Pin Description
GND	2	S	<b>Ground:</b> Normally 0 volts. See Figure 7 for Recommended Power Supply Filtering.
	3		
	4		
	6		
	7		
	9		
	10		
	11		
	12		
	18		
	39		
	52		
	61		
	VCCHS[0,1]		
VCCHS[2,3]	33		
VCCHS[4]	45		
VCCHS[5]	48		
VCCHS[6,7]	58		
VCC	5	S	<b>Logic Power Supply:</b> Normally 3.3 volts. Used for internal logic. See Figure 7 for Recommended Power Supply Filtering.
	8		
	17		
	27		
	64		

**HDMP-0480 Absolute Maximum Ratings**

$T_a = 25^\circ\text{C}$ , except as specified. Operation in excess of any of these conditions may result in permanent damage to this device.  $T_a$  refers to the ambient temperature for the board upon which the parametric measurements were taken.

Symbol	Parameters	Units	Min.	Max.
$V_{CC}$	Supply Voltage	V	-0.7	4.0
$V_{IN, LVTTTL}$	LVTTTL Input Voltage	V	-0.7	4.0
$V_{IN, HS\_IN}$	HS_IN Input Voltage	V	1.3	$V_{CC}$
$I_{O, LVTTTL}$	LVTTTL Output Voltage	mA		$\pm 13$
$T_{stg}$	Storage Temperature	$^\circ\text{C}$	-65	+150
$T_j$	Junction Temperature	$^\circ\text{C}$	0	+125

**HDMP-0480 Guaranteed Operating Rates,  $T_a = 0^\circ\text{C}$  to  $+70^\circ\text{C}$ ,  $V_{CC} = 3.15\text{V}$  to  $3.45\text{V}$**

Serial Clock Rate FC (MBd)		Serial Clock Rate GE (MBd)	
Min.	Max.	Min.	Max.
1,040	1,080	1,240	1,260

**HDMP-0480 DC Electrical Specifications,  $T_a = 0^\circ\text{C}$  to  $+70^\circ\text{C}$ ,  $V_{CC} = 3.15\text{V}$  to  $3.45\text{V}$** 

Symbol	Parameters	Min.	Typ.	Max.	Units
$V_{IH,LVTTL}$	LVTTL Input High Voltage Range	2.0		4.0	V
$V_{IL,LVTTL}$	LVTTL Input Low Voltage Range	0		0.8	V
$V_{OH,LVTTL}$	LVTTL Output High Voltage Range, $I_{OH} = -400\ \mu\text{A}$	2.2		3.45	V
$V_{OL,LVTTL}$	LVTTL Output Low Voltage Level, $I_{OL} = 1\ \text{mA}$	0		0.6	V
$I_{IH,LVTTL}$	Input High Current (Magnitude), $V_{IN} = 2.4\text{V}$ , $V_{CC} = 3.45\text{V}$		.003	40	$\mu\text{A}$
$I_{IL,LVTTL}$	Input Low Current (Magnitude), $V_{IN} = 0.4\text{V}$ , $V_{CC} = 3.45\text{V}$		300	600	$\mu\text{A}$
$I_{CC}$	Total Supply Current, $T_a = 25^\circ\text{C}$		230	280	mA

**HDMP-0480 AC Electrical Specifications,  $T_a = 0^\circ\text{C}$  to  $+70^\circ\text{C}$ ,  $V_{CC} = 3.15\text{V}$  to  $3.45\text{V}$** 

Symbol	Parameters	Min.	Typ.	Max.	Units
$t_{loop}$	Total Loop Latency from FM_NODE[0] to TO_NODE[0]		0.9	2.0	ns
$t_{cell}$	Per Cell Latency from FM_NODE[7] to TO_NODE[0]		0.5	0.8	ns
$t_{r,LVTTLin}$	Input LVTTL Rise Time Requirement, 0.8V to 2.0V		2		ns
$t_{f,LVTTLin}$	Input LVTTL Fall Time Requirement, 2.0V to 0.8V		2		ns
$t_{rs,HS\_OUT}$	HS_OUT Single-Ended Rise Time, 20%-80%		200	350	ps
$t_{fs,HS\_OUT}$	HS_OUT Single-Ended Rise Time, 20%-80%		200	350	ps
$t_{rd,HS\_OUT}$	HS_OUT Differential Rise Time, 20%-80%		200	350	ps
$t_{fd,HS\_OUT}$	HS_OUT Differential Rise Time, 20%-80%		200	350	ps
$V_{IP,HS\_IN}$	HS_IN Input Peak to Peak Required Differential Voltage Range	200	1200	2000	mV
$V_{OP,HS\_OUT}$	HS_OUT Output Pk-Pk Diff. Voltage Range ( $Z_0 = 75\Omega$ , Fig. 5)	1100	1400	2000	mV

**HDMP-0480 Power Dissipation,  $T_a = 0^\circ\text{C}$  to  $+70^\circ\text{C}$ ,  $V_{CC} = 3.15\text{V}$  to  $3.45\text{V}$** 

Symbol	Parameters	Unit	Typ.	Max.
$P_D$	Power Dissipation	mW	760	970

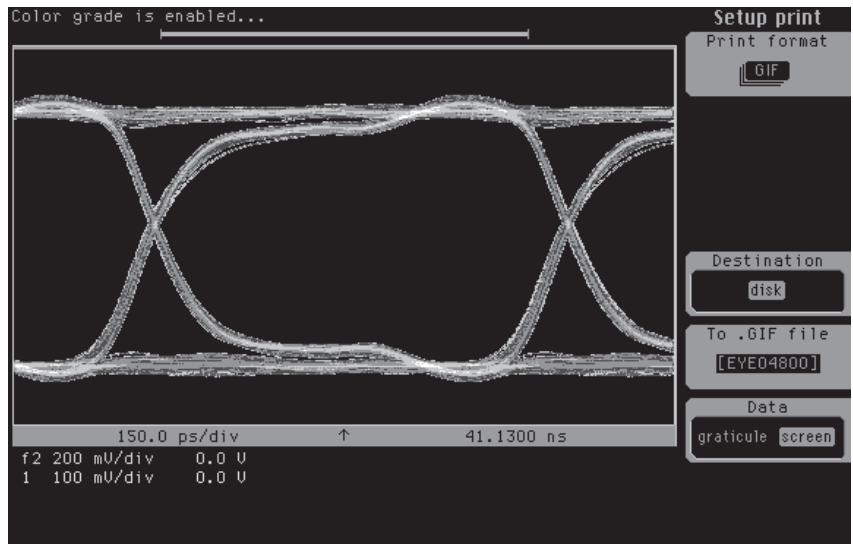

**Figure 3. Eye Diagram of TO\_NODE[1]± High Speed Differential Output.**

Note: Measurement taken with a  $2^7-1$  PRBS input to FM\_NODE[0]±.

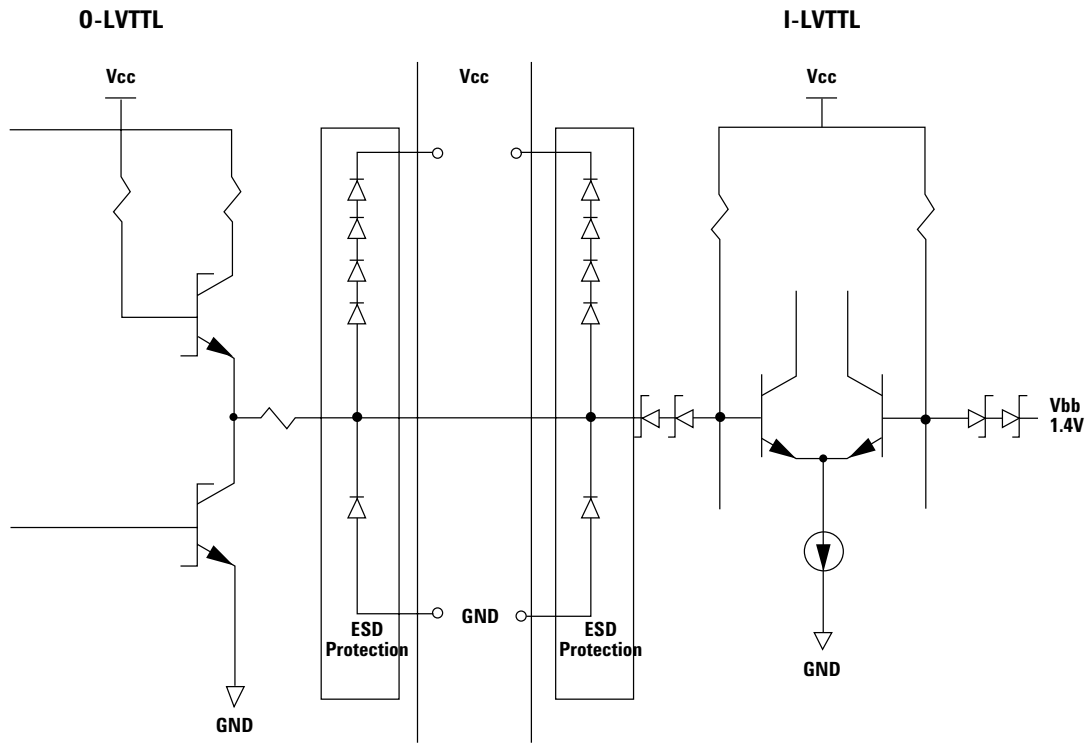

Figure 4. O-LVTTL and I-LVTTL Simplified Circuit Schematic.

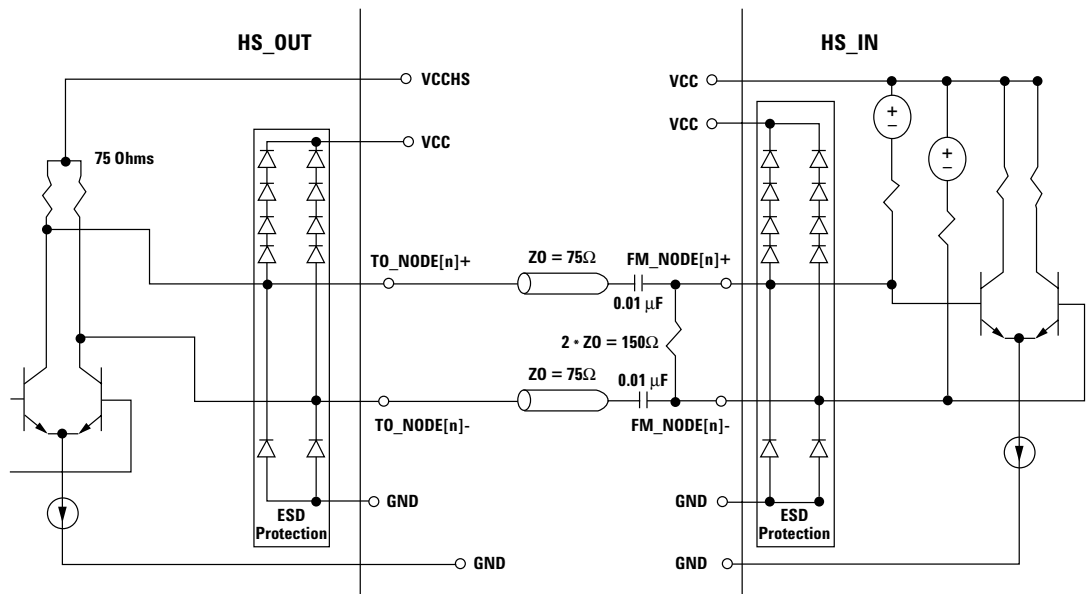

Figure 5. HS\_OUT and HS\_IN Simplified Circuit Schematic.

Note: FM\_NODE[n] inputs should never be connected to ground as permanent damage to the device may result.



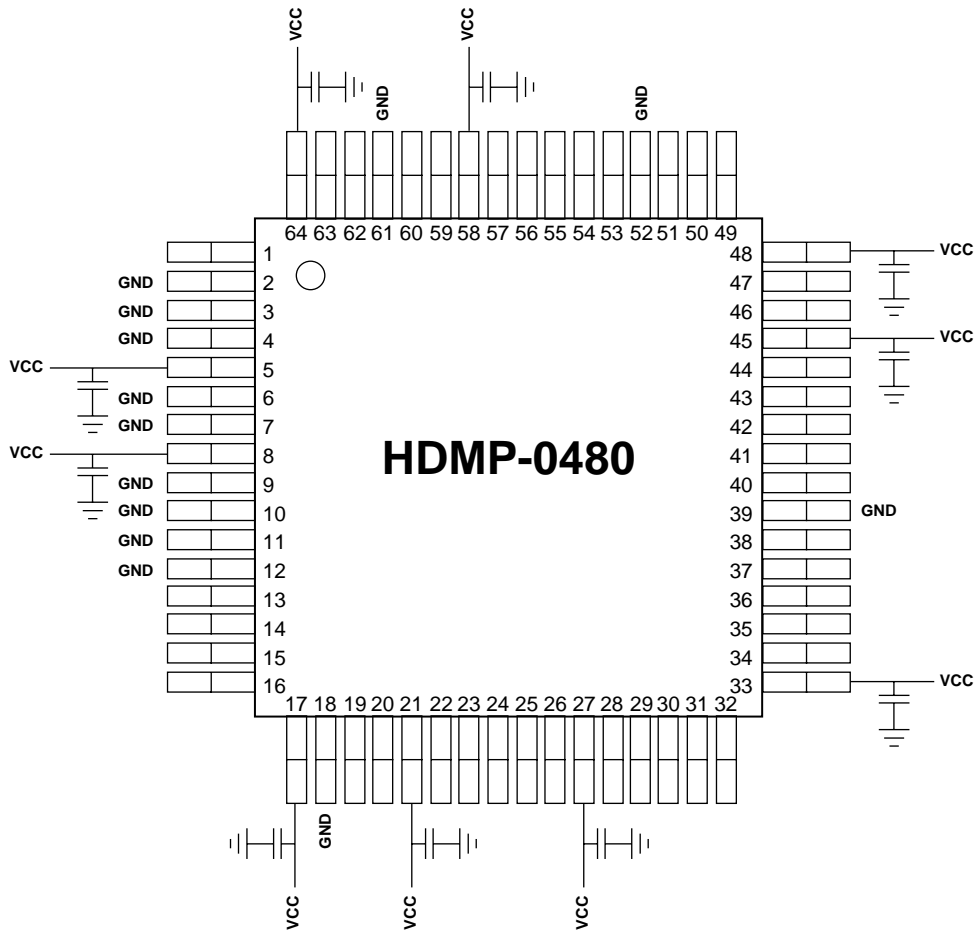

Figure 7. Recommended Power Supply Filtering. Capacitors = 0.1  $\mu$ F.

*www.semiconductor.agilent.com*

Data subject to change.

Copyright © 2001 Agilent Technologies, Inc.

October 24, 2001

5988-4186EN



**Agilent Technologies**



LittleDiode supplies new, hard to find or obsolete electronic components and semiconductors all over the world.

With over two million different components listed you are sure to find the part you need.

Feel free to visit us today at our online store:

[LittleDiode.com](http://LittleDiode.com)

Looking forward to providing you with the best possible service.