

Gigabit Ethernet Transceiver Chip with Dual Serial I/O and Differential PECL Clock Inputs

Technical Data

Features

- **IEEE 802.3z Gigabit Ethernet compatible, Supports 1250 MBd Gigabit Ethernet**
- **Based on X3T11 “10-Bit Specification”**
- **Low Power Consumption**
- **Transmitter and Receiver Functions Incorporated Onto a Single IC**
- **10 mm, 64-Pin Plastic Package**
- **5 Volt Tolerant I/Os**
- **10-Bit Wide Parallel TTL Compatible I/Os**
- **Single +3.3 V Power Supply**
- **Differential PECL Clock Inputs**
- **Dual Serial I/O With Receive Select**
- **2kV ESD Protection on All Pins**

Applications

- **1250 MBd Gigabit Ethernet Interface**
- **High Speed Proprietary Interface**
- **Backplane Serialization/Bus Extender**

Description

The HDMP-1638 transceiver is a single silicon bipolar integrated circuit packaged in a plastic QFP package. It provides a low-cost, low-power physical layer solution for 1250 MBd Gigabit Ethernet or proprietary link interfaces. It provides complete Serialize/Deserialize (“SerDes”) for copper transmission, incorporating both the Gigabit Ethernet transmit and receive functions into a single device.

This chip is used to build a high speed interface (as shown in Figure 1) while minimizing board space, power and cost. It is compatible with the IEEE 802.3z specification.

The transmitter section accepts 10-bit wide parallel TTL data and serializes this data into two high speed serial data streams. The parallel data is expected to be “8B/10B” encoded data, or equivalent. This parallel data is latched into the input register of the transmitter section on the rising edge of the 125 MHz reference clock (used as the transmit byte clock).

The transmitter section’s PLL locks to this user supplied 125 MHz byte clock. This clock is then

HDMP-1638 Transceiver



multiplied by 10, to generate the 1250 MHz serial signal clock used to generate the high speed outputs. The high speed outputs are capable of interfacing directly to copper cables for electrical transmission or to a separate fiber optic module for optical transmission.

The receiver section allows for the selection of one of two serial electrical data streams at 1250 MBd and recovers the original 10-bit wide parallel data. The receiver PLL locks onto the incoming serial signal and recovers the high speed serial clock and data. The serial data is converted back into 10-bit parallel data, recognizing the 8B/10B comma character to establish byte alignment.

CAUTION: As with all semiconductor IC’s, it is advised that normal static precautions be taken in handling and assembly of this component to prevent damage and/or degradation which may be induced by electrostatic discharge (ESD).

The recovered parallel data is presented to the user at TTL compatible outputs. The receiver section also recovers two 62.5 MHz receiver byte clocks which are 180 degrees out of phase with each other. The parallel data is properly aligned with the rising edge of alternating clocks.

For test purposes, the transceiver provides for on-chip local loop-back functionality controlled through an external input pin. Additionally, the byte synchronization feature may be disabled. This may be useful in proprietary applications which use alternative methods to align the parallel data.

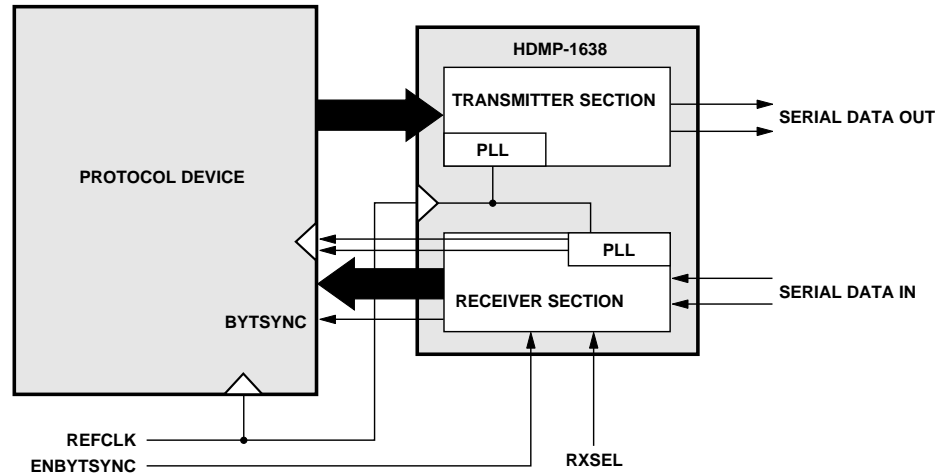

Figure 1. Typical Application Using the HDMP-1638.

HDMP-1638 Block Diagram

The HDMP-1638 was designed to transmit and receive 10-bit wide parallel data over high-speed serial lines. The parallel data applied to the transmitter is expected to be encoded per the Gigabit Ethernet specification, which uses an 8B/10B encoding scheme with special reserve characters for link management purposes. In order to accomplish this task, the HDMP-1638 incorporates the following:

- TTL Parallel I/O's
- High Speed Phase Locked Loops
- Parallel to Serial Converter
- Serial Clock and Data Recovery
- Comma Character Recognition
- Byte Alignment Circuitry
- Serial to Parallel Converter

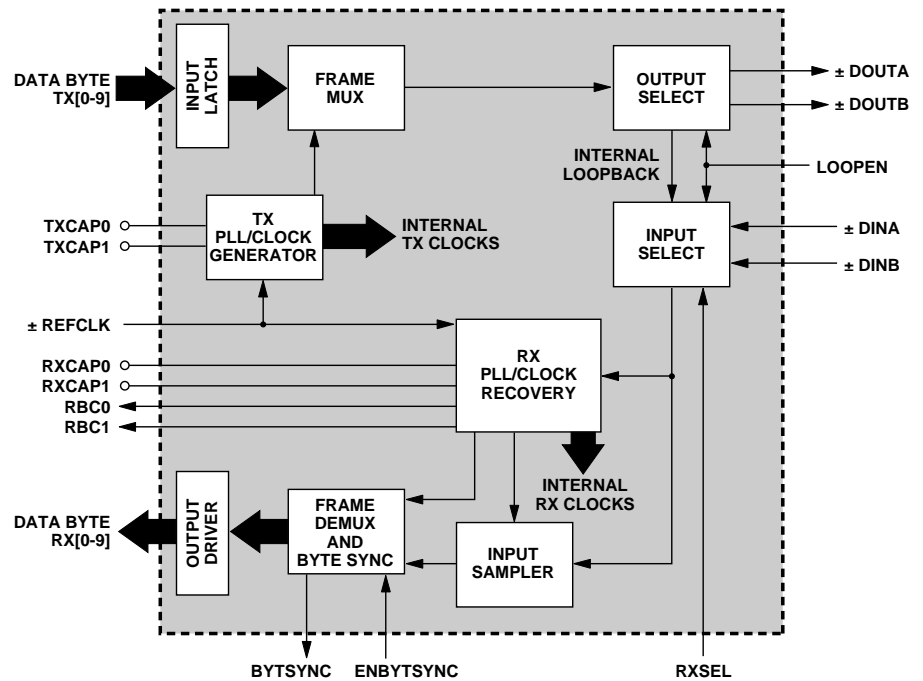

Figure 2. HDMP-1638 Transceiver Block Diagram.

Input Latch

The transmitter accepts 10-bit wide TTL parallel data at inputs TX[0..9]. REFCLK (from this point forward, REFCLK is defined as the difference between the user-provided PECL reference clocks, \pm REFCLK) is used as the transmit byte clock. The TX[0..9] and REFCLK signals must be properly aligned, as shown in Figure 3.

TX PLL/Clock Generator

The transmitter Phase Locked Loop and Clock Generator (TX PLL/CLOCK GENERATOR) block is responsible for generating all internal clocks needed by the transmitter section to perform its functions. These clocks are based on the supplied reference byte clock. REFCLK is used as both the frequency reference clock for the PLL and the transmit byte clock for the incoming data latches. It is expected to be 125 MHz and properly aligned to the incoming parallel data (see Figure 3). This clock is then multiplied by 10 to generate the 1250 MHz clock necessary for the high speed serial outputs.

Frame MUX

The FRAME MUX accepts the 10-bit wide parallel data from the INPUT LATCH. Using internally generated high speed clocks, this parallel data is multiplexed into the 1250 MBd serial data stream. The data bits are transmitted sequentially, from the least significant bit (TX[0]) to the most significant bit (TX[9]).

Output Select

The OUTPUT SELECT block provides for an optional internal loopback of the high speed serial signal for testing purposes.

In normal operation, LOOPEN is set low and the serial data stream is placed at both \pm DOUTA and B. When wrap-mode is activated by setting LOOPEN high, the \pm DOUTA, B pins are held static at logic 1 and the serial output signal is internally wrapped to the INPUT SELECT box of the receiver section.

Input Select

The INPUT SELECT block determines whether one of two pairs of signals \pm DINA, B or the internal loop-back serial signal is used. In normal operation, LOOPEN is set low and the serial data is accepted at \pm DINA or B. RXSEL selects if serial data at \pm DINA or B will be parallelized. If RXSEL is low then \pm DINA will be selected. If RXSEL is high then \pm DINB will be selected. When LOOPEN is set high, the high speed serial signal is internally looped-back from the transmitter section to the receiver section. This feature allows for loop back testing exclusive of the transmission medium.

RX PLL/Clock Recovery

The RX PLL/CLOCK RECOVERY block is responsible for frequency and phase locking onto the incoming serial data stream and recovering the bit and byte

clocks. An automatic locking feature allows the Rx PLL to lock onto the input data stream without external PLL training controls. It does this by continually frequency locking onto the 125 MHz reference clock, and then phase locking onto the input data stream. An internal signal detection circuit monitors the presence of the input, and invokes the phase detection as the data stream appears. Once bit locked, the receiver generates the high speed sampling clock at 1250 MHz for the input sampler, and recovers the two 62.5 MHz receiver byte clocks (RBC1/RBC0). These clocks are 180 degrees out of phase with each other, and are alternately used to clock the 10-bit parallel output data.

Input Sampler

The INPUT SAMPLER is responsible for converting the serial input signal into a retimed serial bit stream. In order to accomplish this, it uses the high speed serial clock recovered from the RX PLL/CLOCK RECOVERY block. This serial bit stream is sent to the FRAME DEMUX and BYTE SYNC block.

Frame Demux and Byte Sync

The FRAME DEMUX AND BYTE SYNC block is responsible for restoring the 10-bit parallel data from the high speed serial bit stream. This block is also responsible for recognizing the comma character (or a K28.5 character) of positive disparity (0011111xxx). When recognized, the FRAME DEMUX AND BYTE SYNC block works with the RX PLL/CLOCK RECOVERY block to properly align the receive byte clocks to the parallel data. When a comma character is detected and realignment of the receiver byte clocks (RBC1/RBC0) is necessary, these clocks are stretched, not slivered, to the next possible correct alignment position. These clocks will be fully aligned by the start of the second 2-byte ordered set. The second comma character received shall be aligned with the rising edge of RBC1. As per the 8B/10B encoding

scheme, comma characters must not be transmitted in consecutive bytes to allow the receiver byte clocks to maintain their proper recovered frequencies.

Output Drivers

The OUTPUT DRIVERS present the 10-bit parallel recovered data byte properly aligned to the receive byte clocks (RBC1/RBC0), as shown in Figure 5. These output data buffers provide TTL compatible signals.

Signal Detect

The SIGNAL DETECT block examines the differential amplitude of the inputs \pm DINB. When this input signal is too small, it outputs a logic 0 at SIG_DET (refer to SIG_DET pin definition for detection thresholds). When the signal at \pm DINB is of a valid amplitude, SIG_DET is set to logic 1.

HDMP-1638 (Transmitter Section)

Timing Characteristics

$T_A = 0\text{ }^\circ\text{C}$ to $+70\text{ }^\circ\text{C}$, $V_{CC} = 3.15\text{ V}$ to 3.45 V

Symbol	Parameter	Units	Min.	Typ.	Max.
t_{setup}	Setup Time	nsec	1.5		
t_{hold}	Hold Time	nsec	1.0		
$t_{\text{txlat}}^{[1]}$	Transmitter Latency	nsec		3.5	
		bits		4.4	

Note:

1. The transmitter latency, as shown in Figure 4, is defined as the time between the latching in of the parallel data word (as triggered by the rising edge of the transmit byte clock, REFCLK) and the transmission of the first serial bit of that parallel word at either output pair (defined by the rising edge of the first bit transmitted).

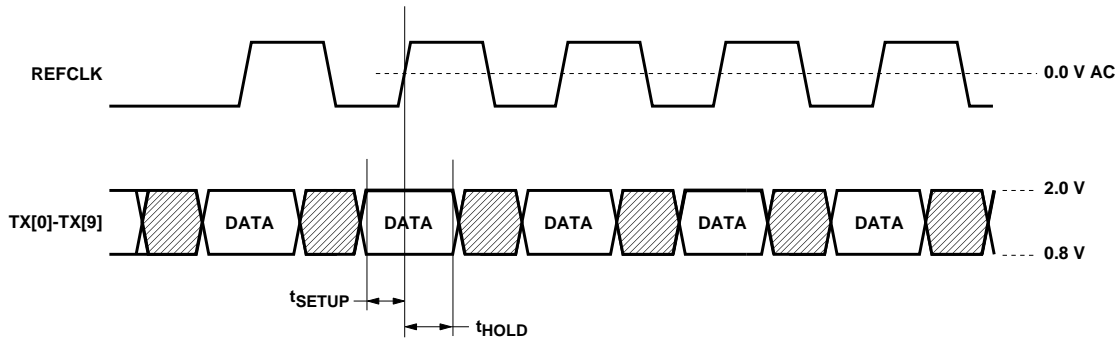

Figure 3: Transmitter Section Timing.

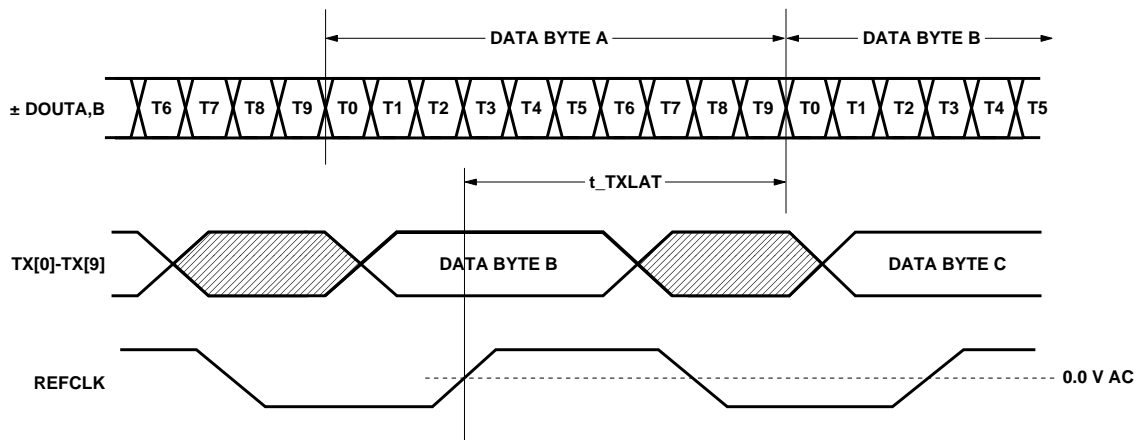

Figure 4: Transmitter Latency.

HDMP-1638 (Receiver Section) Timing Characteristics

$T_A = 0\text{ }^\circ\text{C}$ to $+70\text{ }^\circ\text{C}$, $V_{CC} = 3.15\text{ V}$ to 3.45 V

Symbol	Parameter	Units	Min.	Typ.	Max.
f_lock	Frequency Lock at Powerup	μs			500
b_sync ^[1,2]	Bit Sync Time	bits			2500
t_valid_before	Time Data Valid Before Rising Edge of RBC	nsec	2.5		
t_valid_after	Time Data Valid After Rising Edge of RBC	nsec	1.5		
t_duty	RBC Duty Cycle	%	40		60
t _{A-B} ^[4]	Rising Edge Time Difference Between RBC0 and RBC1	nsec	7.5		8.5
t _{rxlat} ^[3]	Receiver Latency	nsec		22.4	
		bits		28.0	

Notes:

1. This is the recovery time for input phase jumps, per the Fibre Channel Specification X3.230-1994 FC-PH Standard, Sec 5.3.
2. Tested using $C_{PLL}=0.1\text{ }\mu\text{F}$.
3. The receiver latency, as shown in Figure 6, is defined as the time between receiving the first serial bit of a parallel data word (defined as the first edge of the first serial bit) and the clocking out of that parallel word (defined by the rising edge of the receive byte clock, either RBC1 or RBC0).
4. Guaranteed at room temperature.

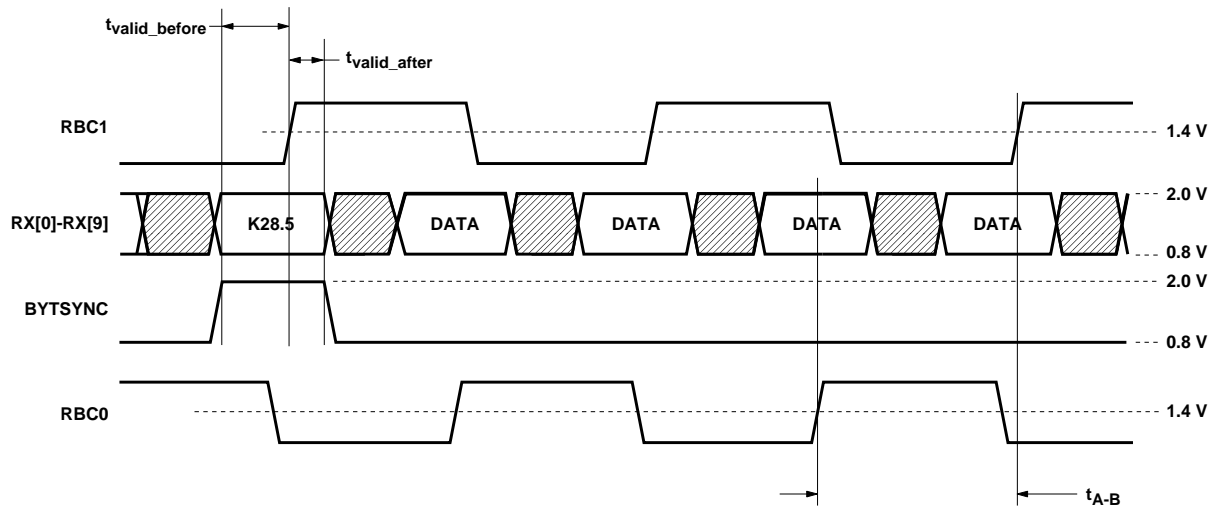

Figure 5: Receiver Section Timing

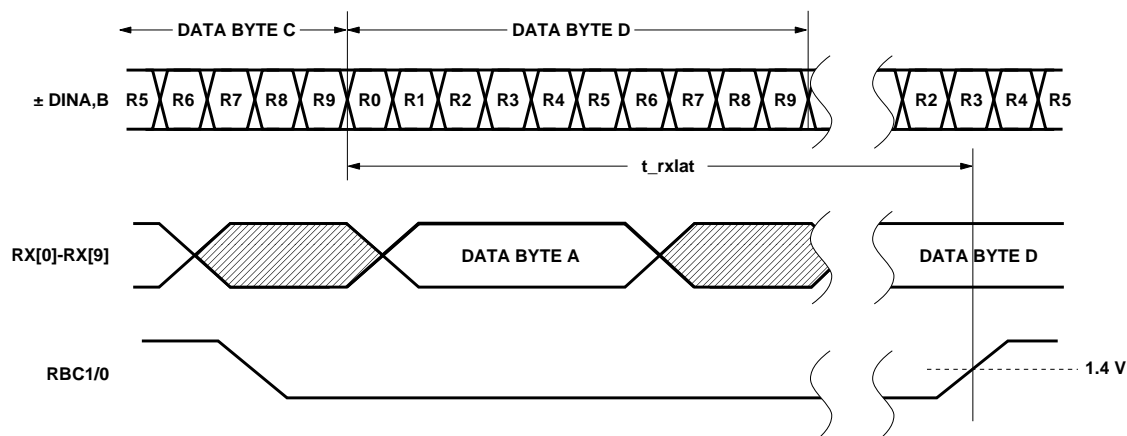

Figure 6: Receiver Latency

HDMP-1638 (TRx)**Absolute Maximum Ratings**

$T_A = 25\text{ }^\circ\text{C}$, except as specified. Operation in excess of any one of these conditions may result in permanent damage to this device.

Symbol	Parameter	Units	Min.	Max.
V_{CC}	Supply Voltage	V	-0.5	5.0
$V_{IN,TTL}$	TTL Input Voltage	V	-0.7	$V_{CC}+2.8$
V_{IN,HS_IN}	HS_IN Input Voltage	V	2.0	V_{CC}
$I_{O,TTL}$	TTL Output Source Current	mA		13
T_{stg}	Storage Temperature	$^\circ\text{C}$	-65	+150
T_j	Junction Temperature	$^\circ\text{C}$	0	+150

HDMP-1638 (TRx)**Guaranteed Operating Rates**

$T_A = 0\text{ }^\circ\text{C}$ to $+70\text{ }^\circ\text{C}$, $V_{CC} = 3.15\text{ V}$ to 3.45 V

Parallel Clock Rate (MHz)		Serial Baud Rate (MBaud)	
Min.	Max.	Min.	Max.
124.0	126.0	1240	1260

HDMP-1638 (TRx)**Transceiver Reference Clock Requirements**

$T_A = 0\text{ }^\circ\text{C}$ to $+70\text{ }^\circ\text{C}$, $V_{CC} = 3.15\text{ V}$ to 3.45 V

Symbol	Parameter	Units	Min.	Typ.	Max.
f	Nominal Frequency (for Gigabit Ethernet Compliance)	MHz		125	
F_{tol}	Frequency Tolerance	ppm	-100		+100
Symm	Symmetry (Duty Cycle)	%	40		60

HDMP-1638 (TRx)**DC Electrical Specifications**

$T_A = 0\text{ }^\circ\text{C}$ to $+70\text{ }^\circ\text{C}$, $V_{CC} = 3.15\text{ V}$ to 3.45 V

Symbol	Parameter	Units	Min.	Typ.	Max.
$V_{IH,TTL}$	TTL Input High Voltage Level, Guaranteed High Signal For All Inputs	V	2		5.5
$V_{IL,TTL}$	TTL Input Low Voltage Level, Guaranteed Low Signal For All Inputs	V	0		0.8
$V_{OH,TTL}$	TTL Output High Voltage Level, $I_{OH} = -400\text{ }\mu\text{A}$	V	2.2		V_{CC}
$V_{OL,TTL}$	TTL Output Low Voltage Level, $I_{OL} = 1\text{ mA}$	V	0		0.6
$I_{IH,TTL}$	Input High Current (Magnitude), $V_{IN} = 2.4\text{ V}$, $V_{CC} = 3.45\text{ V}$	μA			40
$I_{IL,TTL}$	Input Low Current (Magnitude), $V_{IN} = 0.4\text{ V}$, $V_{CC} = 3.45\text{ V}$	μA			-600
$I_{CC,TRx}^{[1,2]}$	Transceiver V_{CC} Supply Current, $T_A = 25\text{ }^\circ\text{C}$	ma		270	

Notes:

1. Measurement Conditions: Tested sending 1250 MBd PRBS 2⁷-1 sequence from a serial BERT with both DOUT outputs biased with 150 Ω resistors.
2. Typical specified with $V_{CC} = 3.3$ volts, maximum specified with $V_{CC} = 3.45$ volts.

HDMP-1638 (TRx)**PECL DC Electrical Specifications**

$T_A = 0\text{ }^\circ\text{C}$ to $+70\text{ }^\circ\text{C}$, $V_{CC} = 3.15\text{ V}$ to 3.45 V

Symbol	Parameter	Units	Min.	Typ.	Max.
$V_{IH,PECL}$	PECL Input High Voltage Level	V	2.14		2.42
$V_{IL,PECL}$	PECL Input Low Voltage Level	V	1.49		1.82

HDMP-1638 (TRx)**AC Electrical Specifications**
 $T_A = 0\text{ }^{\circ}\text{C to }+70\text{ }^{\circ}\text{C}, V_{CC} = 3.15\text{ V to }3.45\text{ V}$

Symbol	Parameter	Units	Min.	Typ.	Max.
$t_{r,TTLin}$	Input TTL Rise Time, 0.8 to 2.0 Volts	nsec		2	
$t_{f,TTLin}$	Input TTL Fall Time, 2.0 to 0.8 Volts	nsec		2	
$t_{r,TTLout}$	Output TTL Rise Time, 0.8 to 2.0 Volts, 10 pF Load	nsec		1.5	2.4
$t_{f,TTLout}$	Output TTL Fall Time, 2.0 to 0.8 Volts, 10 pF Load	nsec		1.1	2.4
t_{rs,HS_OUT}	HS_OUT Single-Ended (+DOUT) Rise Time	psec	85	225	327
t_{fs,HS_OUT}	HS_OUT Single-Ended (+DOUT) Fall Time	psec	85	200	327
t_{rd,HS_OUT}	HS_OUT Differential Rise Time	psec	85		327
t_{fd,HS_OUT}	HS_OUT Differential Fall Time	psec	85		327
V_{IP,HS_IN}	HS_IN Input Peak-To-Peak Differential Voltage	mV	200	1200	2000
$V_{OP,HS_OUT}^{[1]}$	HS_OUT Output Pk-Pk Diff. Voltage ($Z_0=50\ \Omega$, Fig. 10)	mV	1200	1600	2200

Note: 1. Output Peak-to-Peak Differential Voltage specified as DOUT+ minus DOUT-.

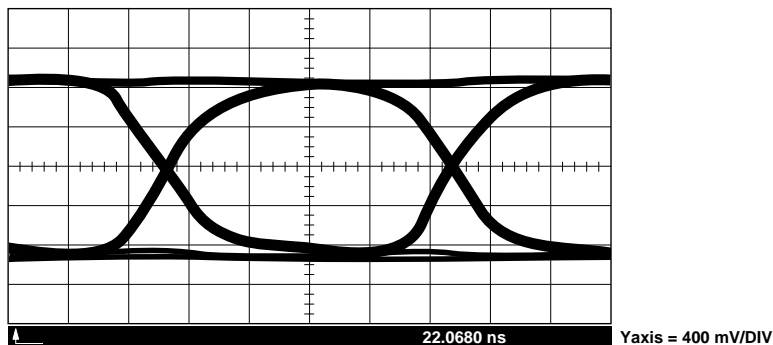

A. DIFFERENTIAL HS_OUT OUTPUT (DOUT+ MINUS DOUT-)

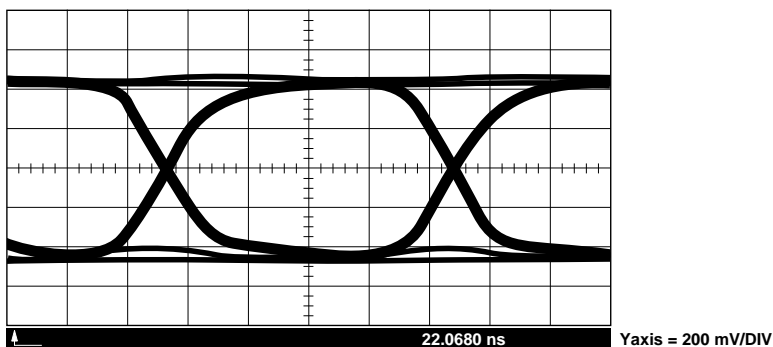

B. SINGLE-ENDED HS_OUT OUTPUT (DOUT+)

Eye Diagrams of the High-Speed Serial Outputs from the HDMP-1638 as Captured on the 83480A Digital Communications Analyzer. Tested with PRBS= 2^7-1 .

Figure 7: Transmitter DOUT Eye Diagrams.

HDMP-1638 (Transmitter Section)

Output Jitter Characteristics

(Measured with equivalent parts which have TTL REFCLK input)

$T_A = 0\text{ }^\circ\text{C}$ to $+70\text{ }^\circ\text{C}$, $V_{CC} = 3.15\text{ V}$ to 3.45 V

Symbol	Parameter	Units	Typ.
RJ ^[1]	Random Jitter at DOUT, the High Speed Electrical Data Port, Specified as 1 Sigma Deviation of the 50% Crossing Point (RMS)	ps	8
DJ ^[1]	Deterministic Jitter at DOUT, the High Speed Electrical Data Port (pk-pk)	ps	TBD

Note:

1. Defined by Fibre Channel Specification X3.230-1994 FC-PH Standard, Annex A, Section A.4 and tested using measurement method shown in Figure 8.

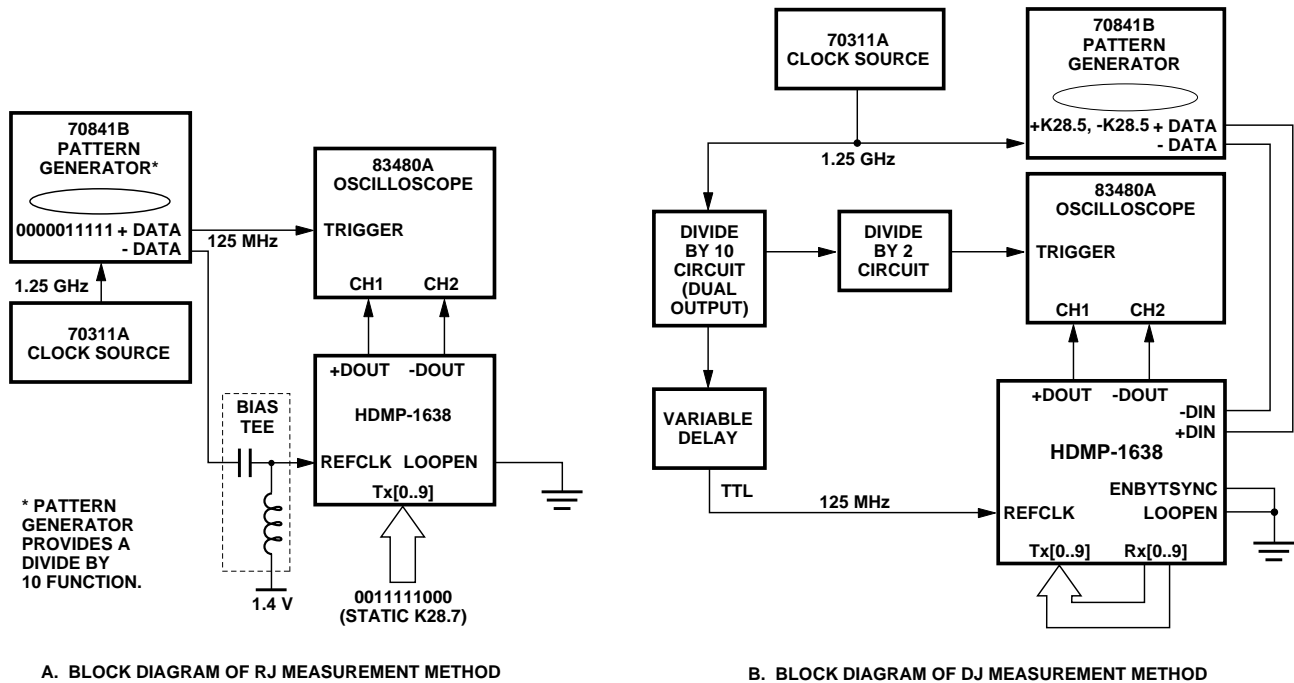

Figure 8: Transmitter Jitter Measurement Method.

HDMP-1638 (TRx)**Thermal and Power Temperature Characteristics**

$T_A = 0\text{ }^{\circ}\text{C}$ to $+70\text{ }^{\circ}\text{C}$, $V_{CC} = 3.15\text{ V}$ to 3.45 V

Symbol	Parameter	Units	Typ.	Max.
$P_{D, TRx}^{[1,2]}$	Transceiver Power Dissipation, one Output Pair Open, Parallel Data Has 5 Ones and 5 Zeroes.	mW	840	TBD
$P_{D, TRx}^{[1,2,3]}$	Transceiver Power Dissipation, Outputs Connected Per Recommended Bias Terminations with Idle Pattern	mW	890	TBD
$\Theta_{jc}^{[4]}$	Thermal Resistance, Junction to Case	$^{\circ}\text{C}/\text{W}$	10	

Notes:

- P_D is obtained by multiplying V_{CC} by I_{CC} and subtracting the power dissipated outside the chip at the high speed bias resistors.
- Typical specified with $V_{CC} = 3.3$ volts, maximum value specified with $V_{CC} = 3.45$ volts.
- Specified with high speed outputs biased with $150\ \Omega$ resistors and receiver TTL outputs driving 10 pF loads.
- Based on independent package testing by Agilent Technologies. Θ_{ja} for these devices is $48\text{ }^{\circ}\text{C}/\text{W}$ for the HDMP-1638. Θ_{ja} is measured on a standard 3×3 " FR4 PCB in a still air environment. To determine the actual junction temperature in a given application, use the following: $T_J = T_C + (\Theta_{jc} \times P_d)$, where T_C is the case temperature measured on the top center of the package and P_D is the power being dissipated.

I/O Type Definitions

I/O Type	Definition
I-TTL	Input TTL, floats high when left open
O-TTL	Output TTL
HS_OUT	High Speed Output, ECL Compatible
HS_IN	High Speed Input
C	External circuit node
S	Power supply or ground
PECL	Positive ECL

HDMP-1638 (TRx) Pin Input Capacitance

Symbol	Parameter	Units	Typ.	Max.
C_{INPUT}	Input Capacitance on TTL Input Pins	pF	1.6	

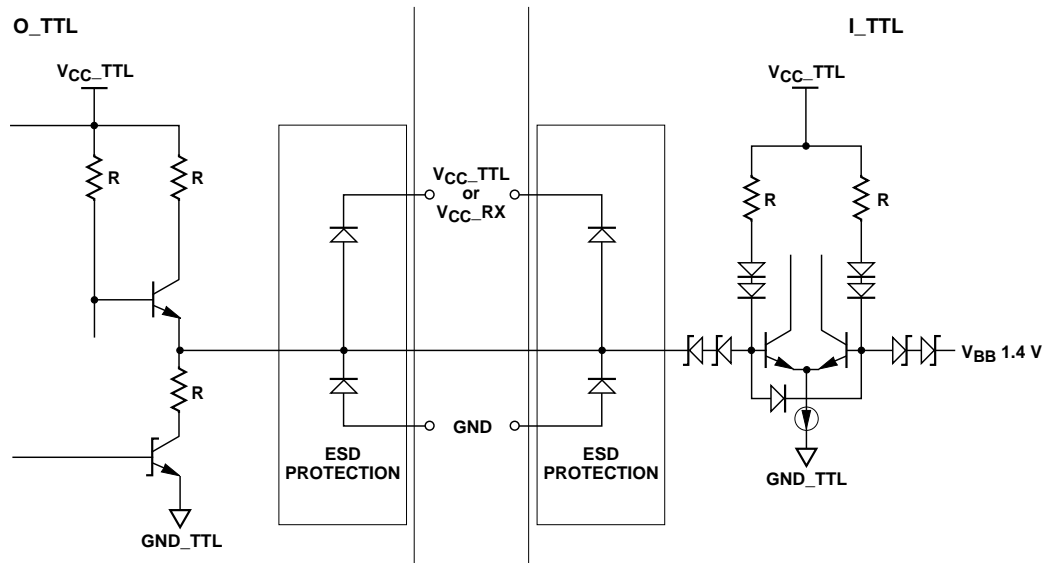
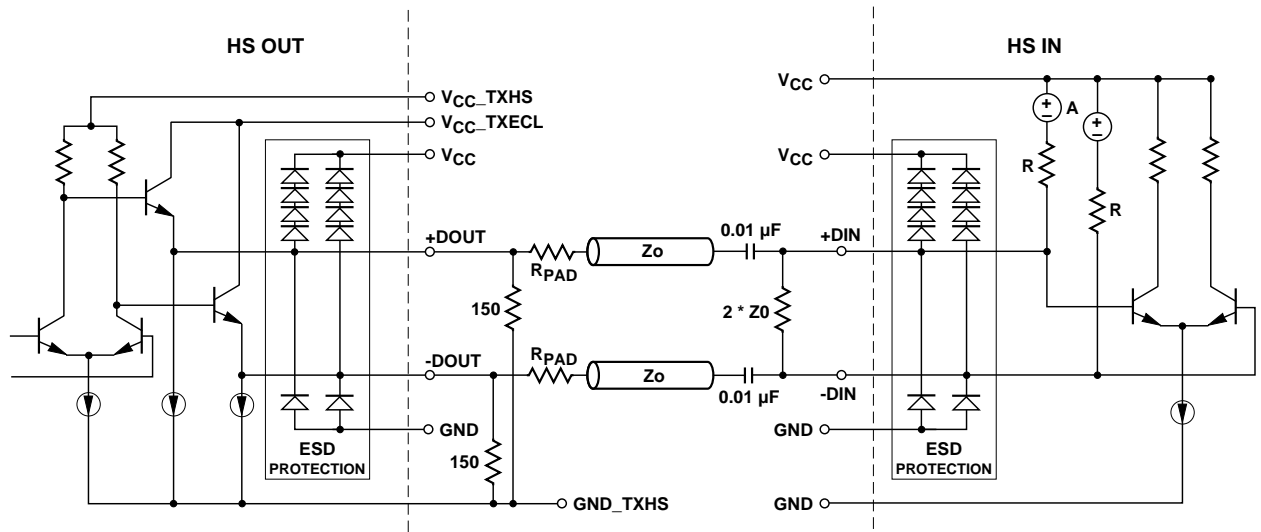

Figure 9: O-TTL and I-TTL Simplified Circuit Schematic.



NOTES:

1. HS_IN INPUTS SHOULD NEVER BE CONNECTED TO GROUND AS PERMANENT DAMAGE TO THE DEVICE MAY RESULT.
2. THE OPTIONAL SERIES PADDING RESISTORS (R_{PAD}) HELP DAMPEN LOAD REFLECTIONS. TYPICAL R_{PAD} VALUES FOR MISMATCHED LOADS RANGE BETWEEN 25- Z_0 Ω .
3. FOR PECL REFCLK INPUT PAIR, THE CONSTANT VOLTAGE SUPPLIES (SHOWN AS A) AND RESISTORS R ARE OMITTED.

Figure 10: HS_OUT and HS_IN Simplified Circuit Schematic.

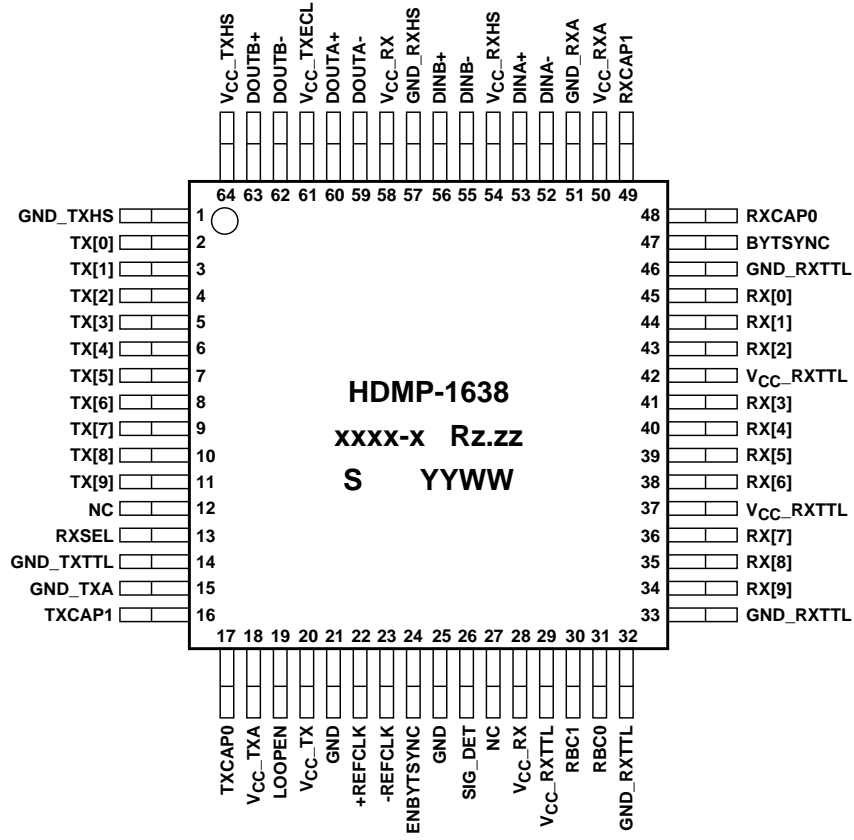

xxxx-x = WAFER LOT NUMBER-BUILD NUMBER
 Rz.zz = DIE REVISION
 S = SUPPLIER CODE
 YYWW = DATE CODE (YY = YEAR, WW = WORK WEEK)
 COUNTRY = COUNTRY OF MANUFACTURE
 (MARKED ON BACK OF DEVICE)

*NOTE: PINS 12 AND 27 ARE DESIGNATED AS "NO CONNECT" PINS AND ARE NORMALLY UNCONNECTED.

HDMP-1638 fig 11

Figure 11: HDMP-1638 (TRx) Package Layout and Marking, Top View.

TRx I/O Definition

NAME	PIN	TYPE	SIGNAL
BYTSYNC	47	O-TTL	Byte Sync Output: An active high output. Used to indicate detection of either a comma character (0011111XXX). It is only active when ENBYTSYNC is enabled.
-DINA +DINA	52 53	HS_IN	Serial Data Inputs: High speed inputs. Serial data is accepted from the \pm DINA inputs when LOOPEN and RXSEL are both low.
-DINB +DINB	55 56	HS_IN	Serial Data Inputs: High speed inputs. Serial data is accepted from the \pm DINB inputs when LOOPEN is low and RXSEL high.
RXSEL	13	I-TTL	Serial Input Select: If this pin is held low then \pm DINA inputs are parallelized. If this pin is held high then \pm DINB inputs are parallelized.
-DOUTA +DOUTA	59 60	HS_OUT	Serial Data Outputs: High speed outputs. These lines are active when LOOPEN is set low. When LOOPEN is set high, these outputs are held static at logic 1. If unused, remove the 150 Ω pulldown resistors to save power.
-DOUTB +DOUTB	62 63	HS_OUT	Serial Data Outputs: High speed outputs. These lines are active when LOOPEN is set low. When LOOPEN is set high, these outputs are held static at logic 1. If unused, remove the 150 Ohm pulldown resistors to save power.
ENBYTSYNC	24	I-TTL	Enable Byte Sync Input: When high, turns on the internal byte sync function to allow clock synchronization to a comma character (0011111XXX). When the line is low, the function is disabled and will not reset registers and clocks, or strobe the BYTSYNC line.
GND	21 25	S	Logic Ground: Normally 0 volts. This ground is used for internal PECL logic. It should be isolated from the noisy TTL ground as well as possible.
GND_RXA	51	S	Analog Ground: Normally 0 volts. Used to provide a clean ground plane for the receiver PLL and high-speed analog cells.
GND_RXHS	57	S	Ground: Normally 0 volts.
GND_RXTTL	32 33 46	S	TTL Receiver Ground: Normally 0 volts. Used for the TTL output cells of the receiver section.
GND_TXA	15	S	Analog Ground: Normally 0 volts. Used to provide a clean ground plane for the PLL and high-speed analog cells.

NAME	PIN	TYPE	SIGNAL
GND_TXHS	1	S	Ground: Normally 0 volts.
GND_TXTTL	14	S	TTL Transmitter Ground: Normally 0 volts. Used for the TTL input cells of the transmitter section.
N/C	27,12		These pins are connected to an isolated pad and have no functionality. They may be left open, however, TTL levels may also be applied to these pins.
LOOPEN	19	I-TTL	Loopback Enable Input: When set high, the high speed serial signal is internally wrapped from the transmitter's serial loopback outputs back to the receiver's loopback inputs. Also when in loopback mode, the \pm DOUT outputs are held static at logic 1. When set low, \pm DOUT outputs and \pm DIN inputs are active.
RBC1 RBC0	30 31	O-TTL	Receiver Byte Clocks: The receiver section recovers two 62.5 MHz receive byte clocks. These two clocks are 180 degrees out of phase. The receiver parallel data outputs are alternately clocked on the rising edge of these clocks. The rising edge of RBC1 aligns with the output of the comma character (for byte alignment) when detected.
+REFCLK -REFCLK	22 23	PECL	Reference Clock and Transmit Byte Clock: A 125 MHz clock supplied by the host system. The transmitter section accepts this signal as the frequency reference clock. It is multiplied by 10 to generate the serial bit clock and other internal clocks. The transmit side also uses this clock as the transmit byte clock for the incoming parallel data TX[0]..TX[9]. It also serves as the reference clock for the receive portion of the transceiver.
RX[0] RX[1] RX[2] RX[3] RX[4] RX[5] RX[6] RX[7] RX[8] RX[9]	45 44 43 41 40 39 38 36 35 34	O-TTL	Data Outputs: One 10 bit data byte. RX[0] is the first bit received. RX[0] is the least significant bit. When there is a loss of input signal at \pm DINB and RXSEL is high, these outputs are held static at logic 1. Refer to SIG_DET (pin 26) pin definition for more details.
RXCAP0 RXCAP1	48 49	C	Loop Filter Capacitor: A loop filter capacitor for the internal PLL must be connected across the RXCAP0 and RXCAP1 pins. (typical value = 0.1 μ F)

NAME	PIN	TYPE	SIGNAL
TX[0] TX[1] TX[2] TX[3] TX[4] TX[5] TX[6] TX[7] TX[8] TX[9]	2 3 4 5 6 7 8 9 10 11	I-TTL	Data Inputs: One 10 bit, 8B/10B encoded data byte. TX[0] is the first bit transmitted. TX[0] is the least significant bit.
TXCAP0 TXCAP1	17 16	C	Loop Filter Capacitor: A loop filter capacitor must be connected across the TXCAP1 and TXCAP0 pins (typical value=0.1 μ F).
SIG_DET	26	O-TTL	Signal Detect: Indicates a loss of signal on the high-speed differential inputs, \pm DINB, as in the case where the transmission cable becomes disconnected. If \pm DIN \geq 200 mV peak-to-peak, SIG_DET=logic 1. If \pm DIN < 200 mV and \pm DIN > 50 mV, SIG_DET=undefined. If \pm DIN \leq 50 mV, SIG_DET=logic 0.
V _{CC_RX}	28 58	S	Logic Power Supply: Normally 3.3 volts. Used for internal receiver PECL logic. It should be isolated from the noisy TTL supply as well as possible.
V _{CC_RXA}	50	S	Analog Power Supply: Normally 3.3 volts. Used to provide a clean supply line for the PLL and high speed analog cells.
V _{CC_RXHS}	54	S	High Speed Supply: Normally 3.3 volts. Used only for the high speed receiver cell (HS_IN). Noise on this line should be minimized for best operation.
V _{CC_RXTTL}	29 37 42	S	TTL Power Supply: Normally 3.3 volts. Used for all TTL receiver output buffer cells.
V _{CC_TX}	20	S	Logic Power Supply: Normally 3.3 volts. Used for internal transmitter PECL logic. Also used for all transmitter TTL input buffer cells.
V _{CC_TXA}	18	S	Analog Power Supply: Normally 3.3 volts. Used to provide a clean supply line for the PLL and high speed analog cells.
V _{CC_TXECL}	61	S	High Speed ECL Supply: Normally 3.3 volts. Used only for the last stage of the high speed transmitter output cell (HS_OUT) as shown in Figure 10. Due to high current transitions, this V _{CC} should be well bypassed to a ground plane.
V _{CC_TXHS}	64	S	High Speed Supply: Normally 3.3 volts. Used by the transmitter side for the high speed circuitry. Noise on this line should be minimized for best operation.

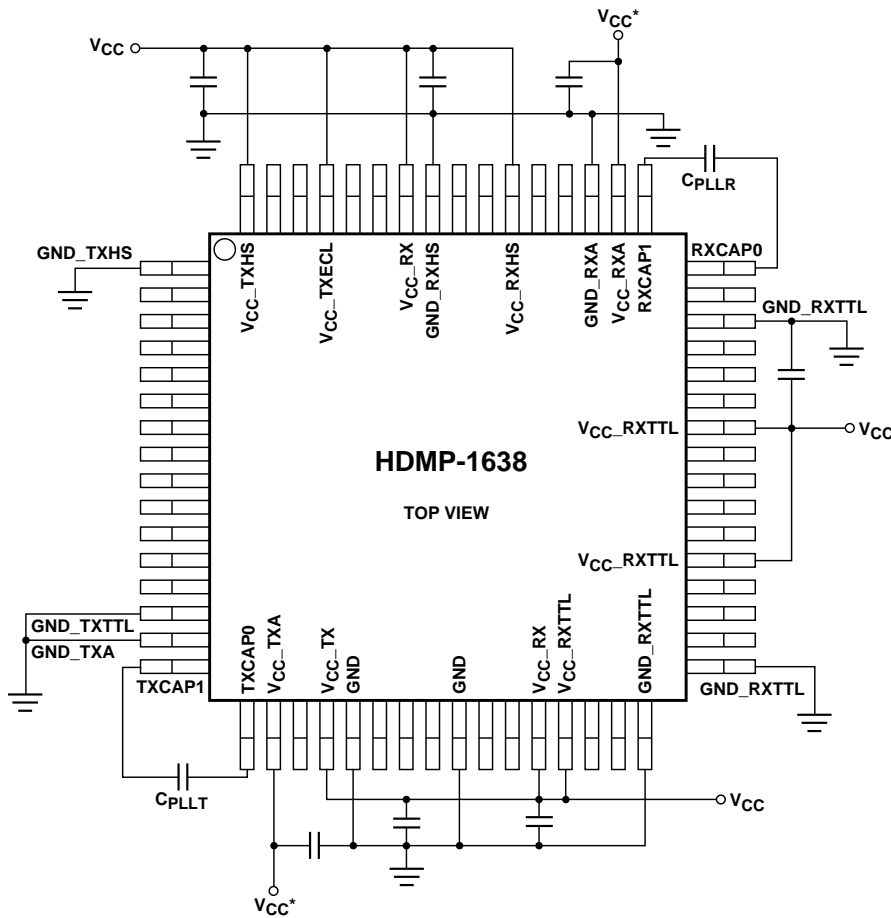

* SUPPLY VOLTAGE INTO V_{CC_RXA} AND V_{CC_TXA} SHOULD BE FROM A LOW NOISE SOURCE. ALL BYPASS CAPACITORS AND PLL FILTER CAPACITORS ARE 0.1 μF .

Figure 12: Power Supply Bypass.

Start Up Procedure:

The transceiver startup procedure(s) and the following conditions:
 $V_{CC} = +3.3 \text{ V} \pm 5 \%$ and $\text{REFCLK} = 125 \text{ MHz} \pm 100 \text{ ppm}$.

After the above conditions have been met, apply valid data using a balanced code such as 8B/10B. Frequency lock occurs within 500 μs . After frequency lock, phase lock occurs within 2500 bit times.

Transceiver Power Supply Bypass and Loop Filter Capacitors

If desired, bypass capacitors may be used on the power supply pins of the HDMP-1638. All bypass chip capacitors are 0.1 μF . The V_{CC_RXA} and V_{CC_TXA} pins are the analog power supply pins for the PLL sections. The supply into these pins should be clean with minimum noise. Use of capacitors as shown in Figure 12 is mandatory for these pins. The PLL loop filter capacitors and their pin locations are also shown on Figure 12. Notice that only two capacitors are required; C_{PLL} for the transmitter and C_{PLL} for the receiver. Nominal capacitance is 0.1 μF . The maximum voltage across the capacitors is on the order of 1 volt, so the capacitor can be a low voltage type and physically small. The PLL capacitors are to be placed physically close to the appropriate pins on the HDMP-1638. Keeping the lines short will prevent them from picking up any stray noise from surrounding lines or components.

Package Information

Item	Details
Package Material	Plastic
Lead Finish Material	85% Tin, 15% Lead
Lead Finish Thickness	300–800 μm
Lead Coplanarity	0.08 mm max

Mechanical Dimensions

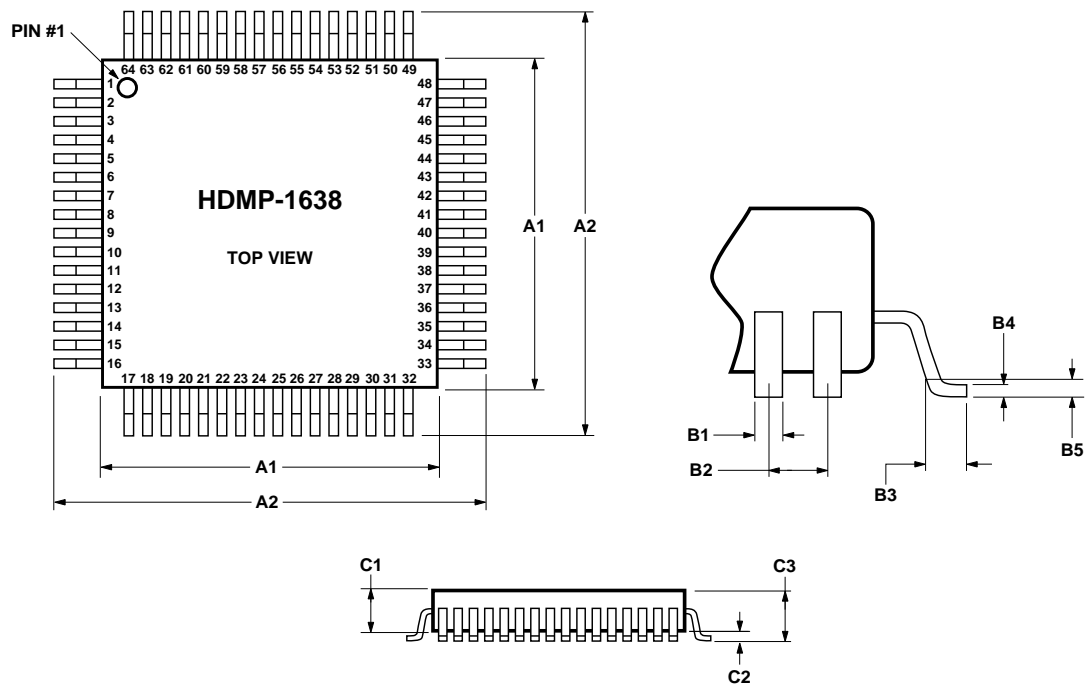

ALL DIMENSIONS ARE IN MILLIMETERS.

PART NUMBER	A1	A2	B1	B2	B3	B4	B5	C1	C2	C3
HDMP-1638	10.00	13.20	0.22	0.50	0.88	0.17	0.25	2.00	0.25 MIN.	2.45
TOLERANCE	± 0.10	± 0.25	± 0.05	BASIC	+ 0.15/ - 0.10	MAX.		+ 0.10/ - 0.05		MAX.

Figure 13: Mechanical Dimensions of HDMP-1638.

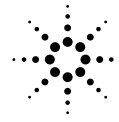

Agilent Technologies
Innovating the HP Way

www.semiconductor.agilent.com

Data subject to change.

Copyright © 1999 Agilent Technologies, Inc.

5968-5120E (11/99)



LittleDiode supplies new, hard to find or obsolete electronic components and semiconductors all over the world.

With over two million different components listed you are sure to find the part you need.

Feel free to visit us today at our online store:

LittleDiode.com

Looking forward to providing you with the best possible service.