

DATA SHEET

For a complete data sheet, please also download:

- The IC04 LOCMOS HE4000B Logic Family Specifications HEF, HEC
- The IC04 LOCMOS HE4000B Logic Package Outlines/Information HEF, HEC

HEF4007UB

gates

Dual complementary pair and inverter

Product specification
File under Integrated Circuits, IC04

January 1995

Dual complementary pair and inverter

HEF4007UB gates

DESCRIPTION

The HEF4007UB is a dual complementary pair and an inverter with access to each device. It has three n-channel and three p-channel enhancement mode MOS transistors.

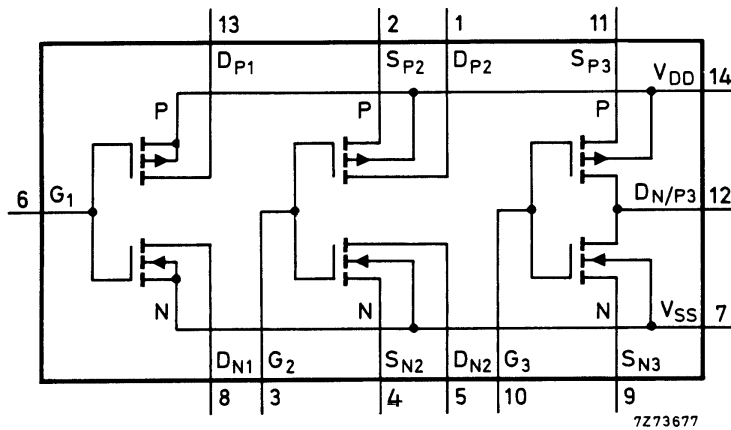

Fig.1 Schematic diagram.

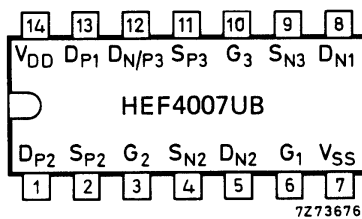

Fig.2 Pinning diagram.

PINNING

- SP₂, SP₃ source connections to 2nd and 3rd p-channel transistors
- DP₁, DP₂ drain connections from the 1st and 2nd p-channel transistors
- DN₁, DN₂ drain connections from the 1st and 2nd n-channel transistors
- SN₂, SN₃ source connections to the 2nd and 3rd n-channel transistors
- DN/P₃ common connection to the 3rd p-channel and n-channel transistor drains
- G₁ to G₃ gate connections to n-channel and p-channel of the three transistor pairs

- HEF4007UBP(N): 14-lead DIL; plastic (SOT27-1)
- HEF4007UBD(F): 14-lead DIL; ceramic (cerdip) (SOT73)
- HEF4007UBT(D): 14-lead SO; plastic (SOT108-1)
- (): Package Designator North America

FAMILY DATA, I_{DD} LIMITS category GATES

See Family Specifications for V_{IH}/V_{IL} unbuffered stages

Dual complementary pair and inverter

HEF4007UB
gates**AC CHARACTERISTICS** $V_{SS} = 0$ V; $T_{amb} = 25$ °C; $C_L = 50$ pF; input transition times ≤ 20 ns

	V_{DD} V	SYMBOL	TYP.	MAX.		TYPICAL EXTRAPOLATION FORMULA
Propagation delays $G_n \rightarrow D_N$; D_P HIGH to LOW	5	t_{PHL}	40	80	ns	$13 \text{ ns} + (0,55 \text{ ns/pF}) C_L$
	10		20	40	ns	$9 \text{ ns} + (0,23 \text{ ns/pF}) C_L$
	15		15	30	ns	$7 \text{ ns} + (0,16 \text{ ns/pF}) C_L$
LOW to HIGH	5	t_{PLH}	40	75	ns	$13 \text{ ns} + (0,55 \text{ ns/pF}) C_L$
	10		20	40	ns	$9 \text{ ns} + (0,23 \text{ ns/pF}) C_L$
	15		15	30	ns	$7 \text{ ns} + (0,16 \text{ ns/pF}) C_L$
Output transition times HIGH to LOW	5	t_{THL}	60	120	ns	$10 \text{ ns} + (1,0 \text{ ns/pF}) C_L$
	10		30	60	ns	$9 \text{ ns} + (0,42 \text{ ns/pF}) C_L$
	15		20	40	ns	$6 \text{ ns} + (0,28 \text{ ns/pF}) C_L$
LOW to HIGH	5	t_{TLH}	60	120	ns	$10 \text{ ns} + (1,0 \text{ ns/pF}) C_L$
	10		30	60	ns	$9 \text{ ns} + (0,42 \text{ ns/pF}) C_L$
	15		20	40	ns	$6 \text{ ns} + (0,28 \text{ ns/pF}) C_L$

	V_{DD} V	TYPICAL FORMULA FOR P (μ W)	
Dynamic power dissipation per package (P)	5	$4500 f_i + \sum (f_o C_L) \times V_{DD}^2$	where f_i = input freq. (MHz) f_o = output freq. (MHz) C_L = load capacitance (pF) $\sum(f_o C_L)$ = sum of outputs V_{DD} = supply voltage (V)
	10	$20\,000 f_i + \sum (f_o C_L) \times V_{DD}^2$	
	15	$50\,000 f_i + \sum (f_o C_L) \times V_{DD}^2$	

Dual complementary pair and inverter

HEF4007UB
gates

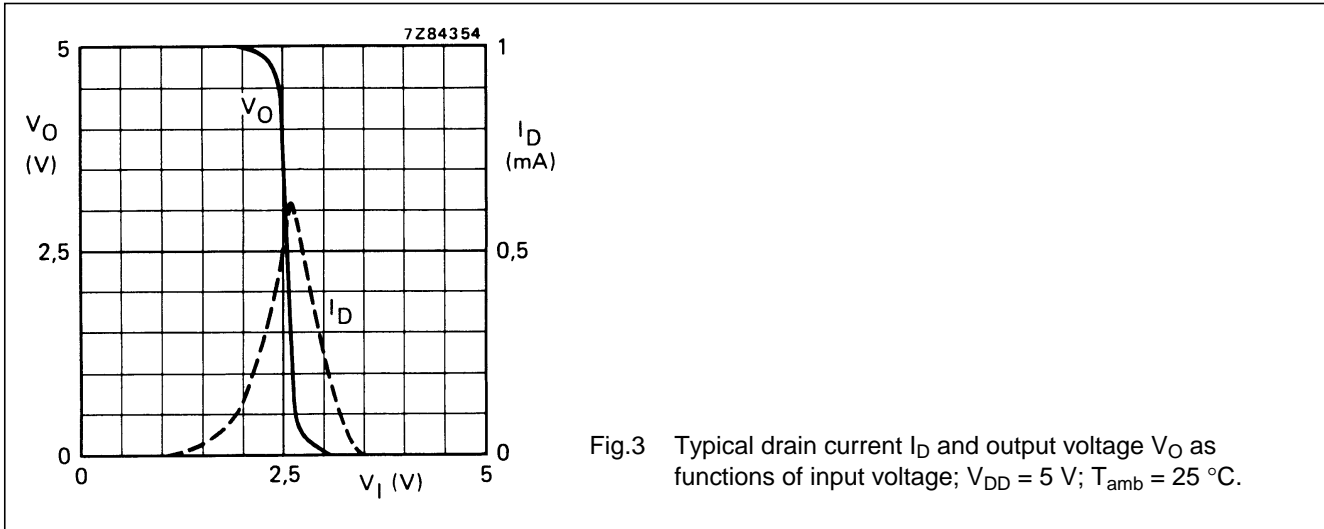

Fig.3 Typical drain current I_D and output voltage V_O as functions of input voltage; $V_{DD} = 5$ V; $T_{amb} = 25$ °C.

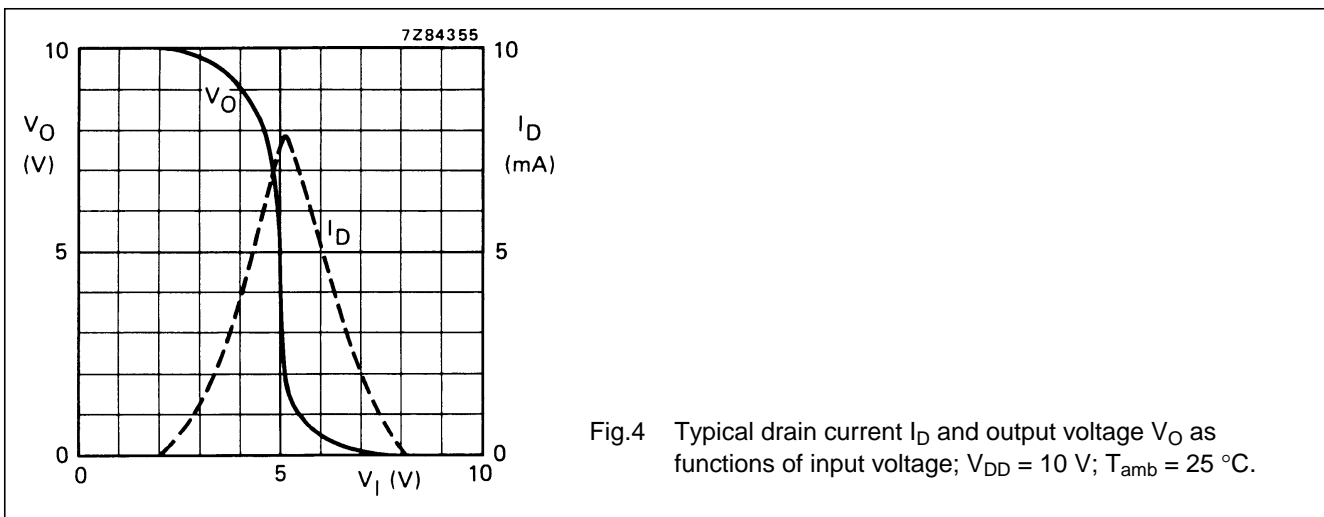

Fig.4 Typical drain current I_D and output voltage V_O as functions of input voltage; $V_{DD} = 10$ V; $T_{amb} = 25$ °C.

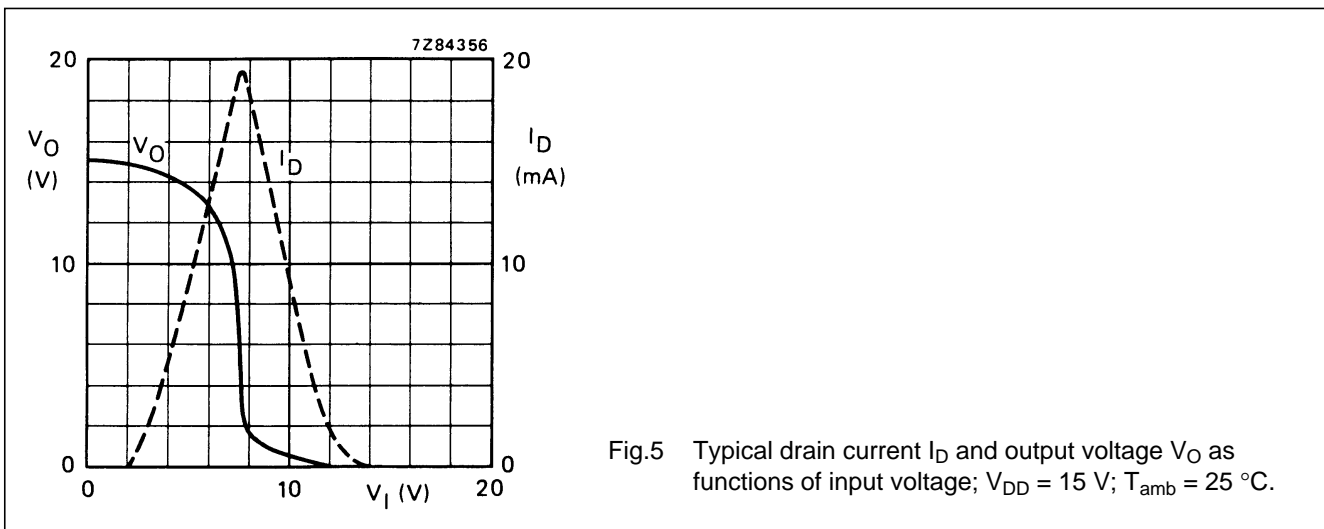

Fig.5 Typical drain current I_D and output voltage V_O as functions of input voltage; $V_{DD} = 15$ V; $T_{amb} = 25$ °C.

Dual complementary pair and inverter

HEF4007UB
gates

APPLICATION INFORMATION

Some examples of applications for the HEF4007UB are:

- High input impedance amplifiers
- Linear amplifiers
- (Crystal) oscillators
- High-current sink and source drivers
- High impedance buffers.

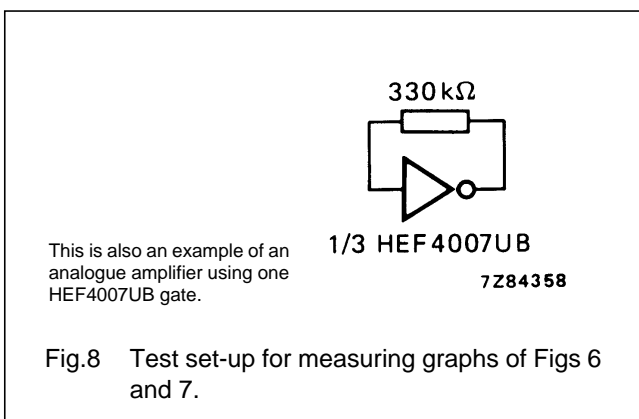
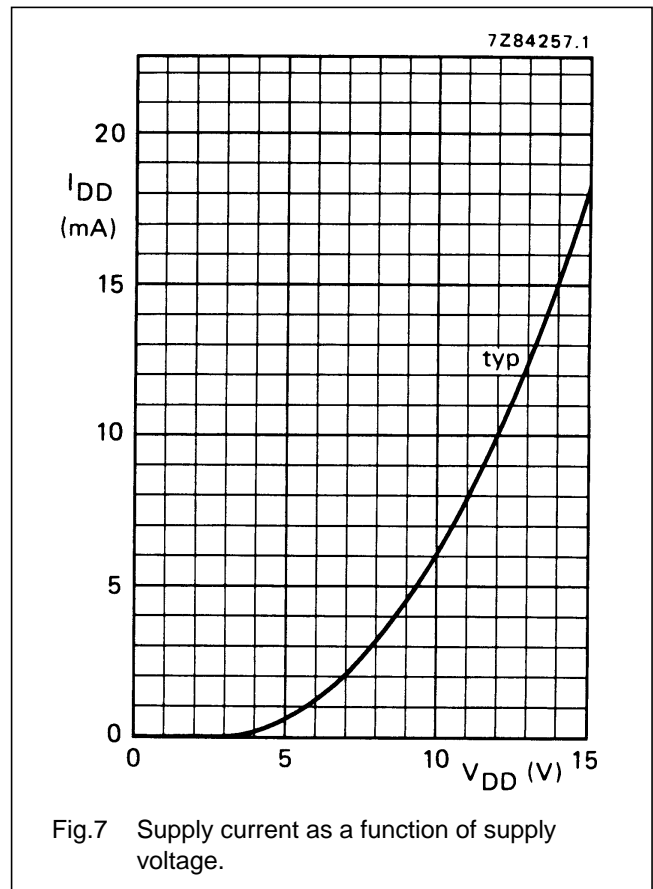
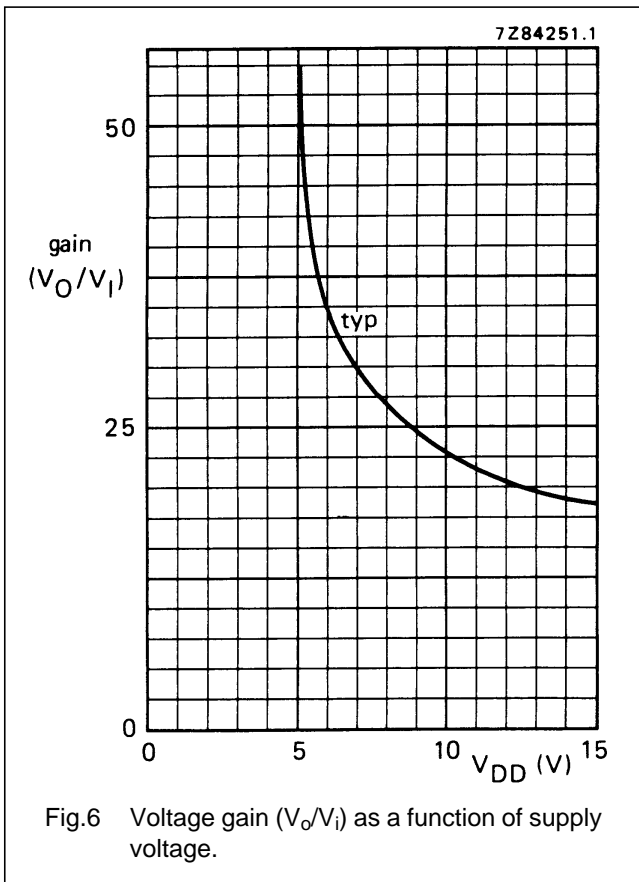

Dual complementary pair and inverter

HEF4007UB
gates

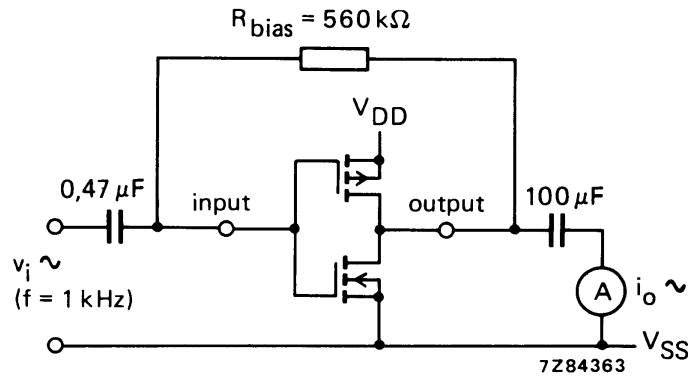
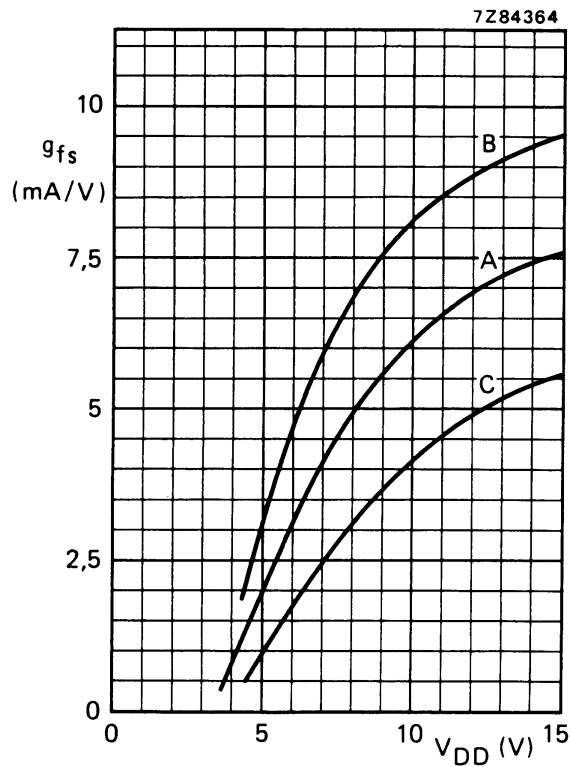

Fig.9 Test set-up for measuring forward transconductance $g_{fs} = di_o/dv_i$ at v_o is constant (see also graph Fig.10).



A: average,
 B: average + 2 s,
 C: average - 2 s, in where 's' is the observed standard deviation.

Fig.10 Typical forward transconductance g_{fs} as a function of the supply voltage at $T_{amb} = 25\text{ }^\circ\text{C}$.

Dual complementary pair and inverter

HEF4007UB
gates

Figures 11 to 14 show some applications in which the HEF4007UB is used.

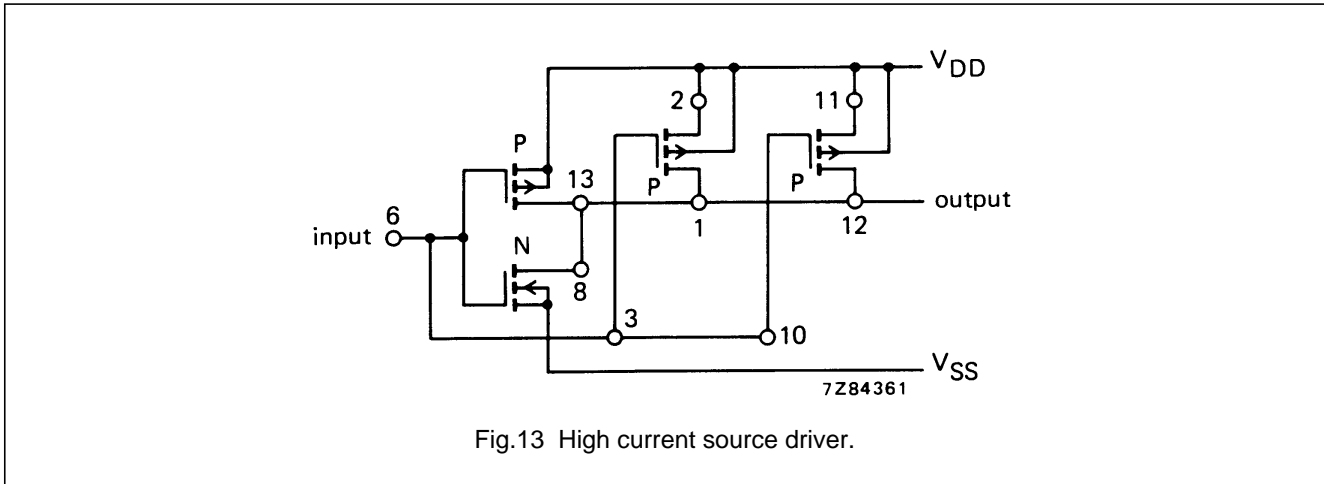
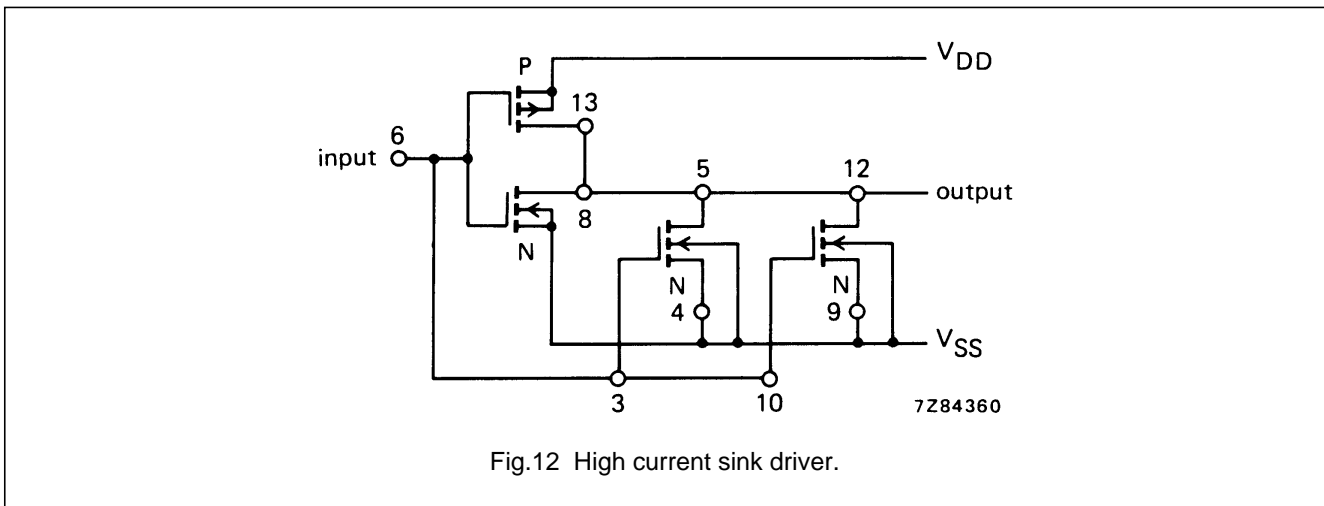
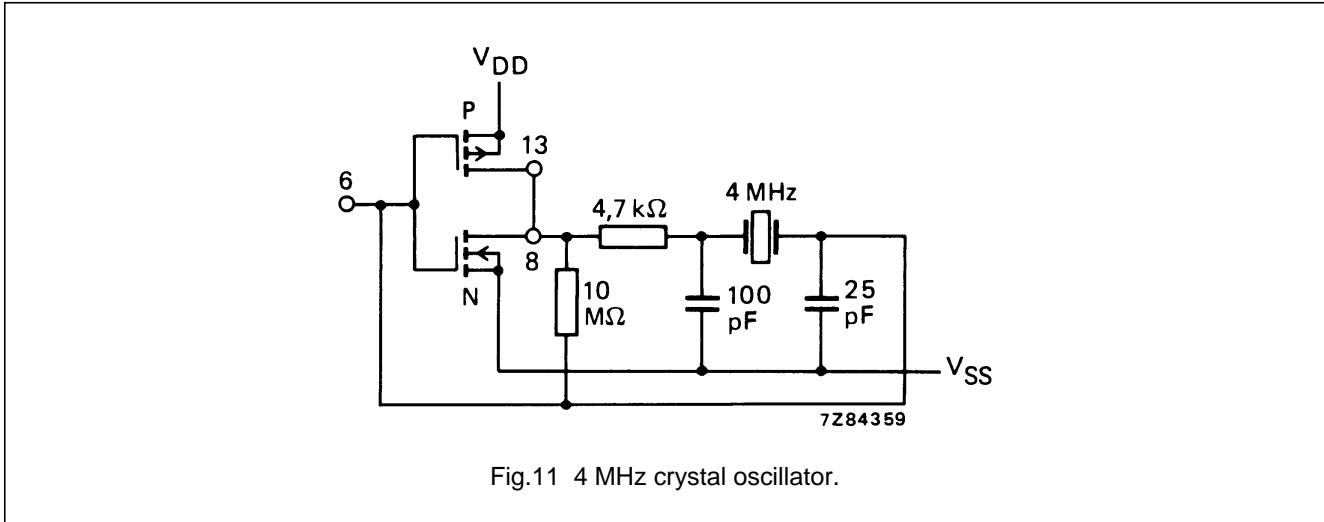

Dual complementary pair and inverter

HEF4007UB
gates

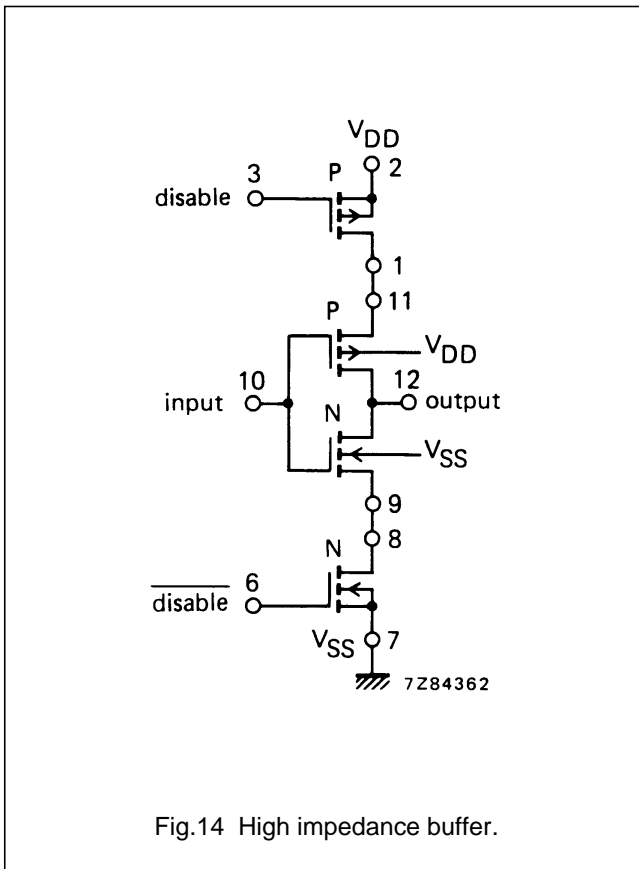

FUNCTION TABLE for Fig.14.

INPUT	DISABLE	OUTPUT
H	L	L
L	L	H
X	H	open

Notes

- H = HIGH state (the more positive voltage)
L = LOW state (the less positive voltage)
X = state is immaterial

NOTE

Rules for maintaining electrical isolation between transistors and monolithic substrate:

- Pin number 14 must be maintained at the most positive (or equally positive) potential with respect to any other pin of the HEF4007UB.
- Pin number 7 must be maintained at the most negative (or equally negative) potential with respect to any other pin of the HEF4007UB.

Violation of these rules will result in improper transistor operation and/or possible permanent damage to the HEF4007UB.



LittleDiode supplies new, hard to find or obsolete electronic components and semiconductors all over the world.

With over two million different components listed you are sure to find the part you need.

Feel free to visit us today at our online store:

LittleDiode.com

Looking forward to providing you with the best possible service.