

DATA SHEET

For a complete data sheet, please also download:

- The IC04 LOCMOS HE4000B Logic Family Specifications HEF, HEC
- The IC04 LOCMOS HE4000B Logic Package Outlines/Information HEF, HEC

HEF4534B

LSI

Real time 5-decade counter

Product specification
File under Integrated Circuits, IC04

January 1995

Real time 5-decade counter

HEF4534B
LSI

DESCRIPTION

The HEF4534B is a 5-decade ripple counter. The binary outputs of the decade counters are time-multiplexed by an internal scanner on four BCD outputs (O_0 to O_3). The selected decade is indicated by a logic HIGH on the appropriate digit select output (OS_0 : units, 1; OS_1 : tens, 10; OS_2 : hundreds, 10^2 ; OS_3 : thousands, 10^3 ; OS_4 : ten thousands, 10^4).

The binary outputs (O_0 to O_3) and the select outputs (OS_0 to OS_4) are 3-state controlled via enable inputs \overline{EO} and \overline{EOS} respectively, allowing interface with other bus orientated devices. Cascading may be accomplished by using the carry out (TC). The counter is triggered by a LOW to HIGH transition on the decade clock (CPA) and is reset by a HIGH level on the master reset (MR). The

scanner is triggered by a LOW to HIGH transition on the scanner clock (CPS) and is reset (select ten thousand counter) by a HIGH level on the scanner reset (MR_{sc}).

The counter can operate in four modes depending on the state of the mode select inputs (S_A , S_B). The error detector will detect an error when a positive edge on CPA is not accompanied by a negative edge on the error detector clock \overline{CPE} or vice versa, within time limits adjusted by external capacitors connected to C_{ext1} and C_{ext2} . Three or more detected errors result in a HIGH level on the error output (OER). The error detector is reset by a HIGH level on MR.

Schmitt-trigger action in the clock inputs makes the circuit highly tolerant to slower clock rise and fall times.

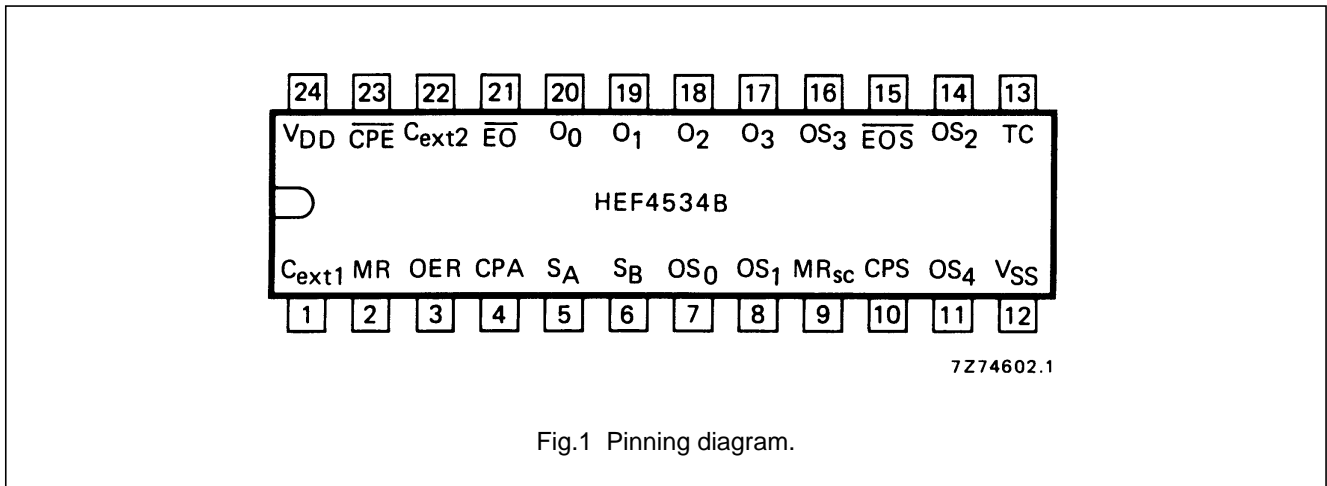

Fig.1 Pinning diagram.

- HEF4534BP(N): 24-lead DIL; plastic (SOT101-1)
- HEF4534BD(F): 24-lead DIL; ceramic (cerdip) (SOT94)
- HEF4534BT(D): 24-lead SO; plastic (SOT137-1)
- (): Package Designator North America

PINNING

O_1 to O_3	BCD outputs
OS_0 to OS_3	digit select outputs
OER	error output
CPA	decade clock input
CPS	scanner clock input
\overline{CPE}	error detector clock input
S_A , S_B	mode select inputs
MR	master reset input
MR_{sc}	scanner reset input
TC	carry out

FAMILY DATA, I_{DD} LIMITS category LSI

See Family Specifications

Real time 5-decade counter

HEF4534B
LSI

MODE CONTROL FUNCTION TABLE

SELECT INPUTS		1ST DECADE OUTPUT	CARRY TO 2ND STAGE	CARRY TO 4TH STAGE	MODE
S _A	S _B				
L	L	normal count and display	at 9 to 0 transition of the 1st decade	at 9 to 0 transition of the 3rd decade	5-decade counter
L	H	inhibited	input clock	input clock	test purposes: clock directly into stages 1, 2 and 4
H	H	inhibited	at 4 to 5 transition of the 1st decade	at 9 to 0 transition of the 3rd decade	4-decade counter with ÷ 10 and round-off at front end
H	L	display counts: 3, 4, 5, 6, 7 = 5 8, 9, 0, 1, 2 = 0	at 7 to 8 transition of the 1st decade	at 9 to 0 transition of the 3rd decade	4-decade counter; 1/2-pence capability

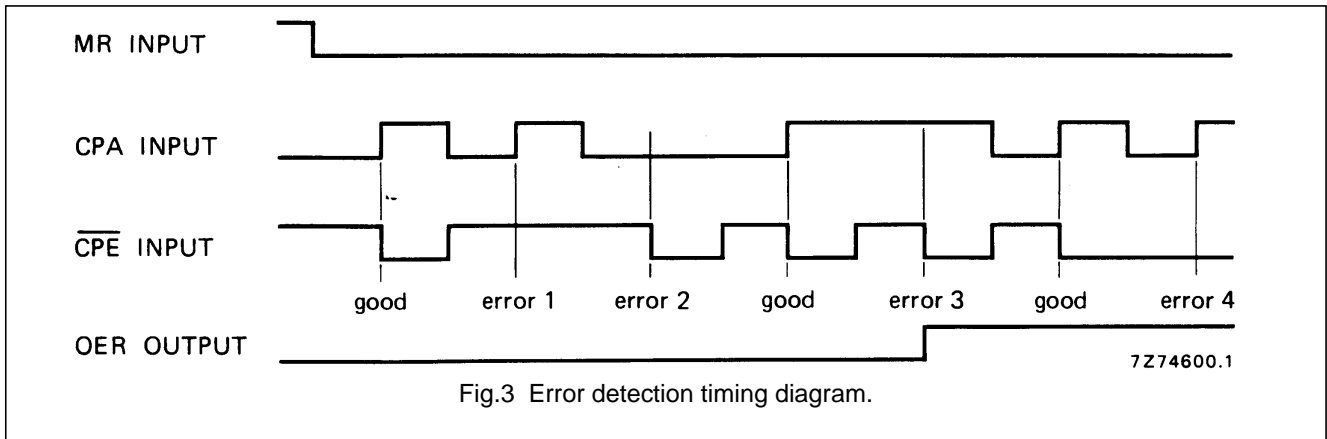

The skew time is the time difference between the LOW to HIGH transition of CPA and the HIGH to LOW transition of CPE or vice versa (see Fig.4). The skew time is typically proportional to the external capacitor (C_{ext}) connected from C_{ext1} and C_{ext2} (pins 1 and 22) to V_{SS}. The error detector will count an error when a positive edge on the counter clock CPA is not succeeded by a negative edge on

the error detector clock CPE within a skew time t_{SK1} (adjustable by C_{ext1} at pin 1). The same holds for a negative edge at CPE succeeded by a positive on CPA within a skew time t_{SK2} (adjustable by C_{ext2} at pin 22). If error detection is not needed, CPE must be either HIGH or LOW and no C_{ext} is applied. For further information see Fig.5.

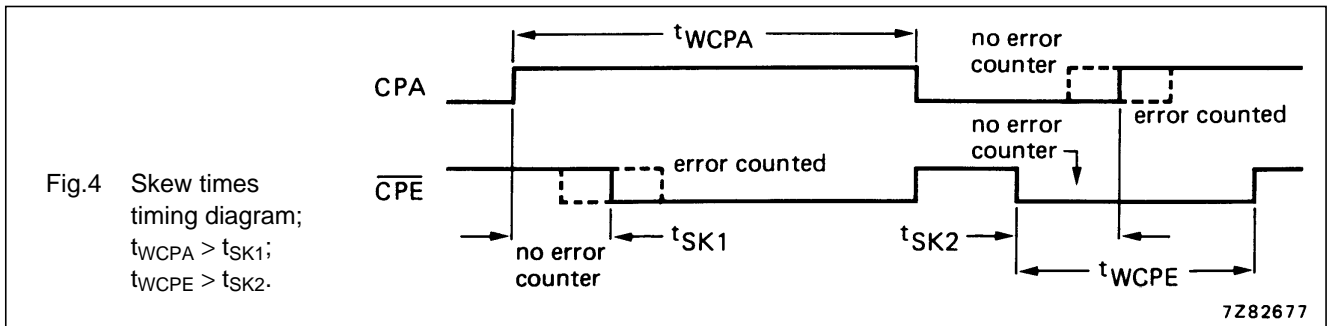

Real time 5-decade counter

HEF4534B
LSI

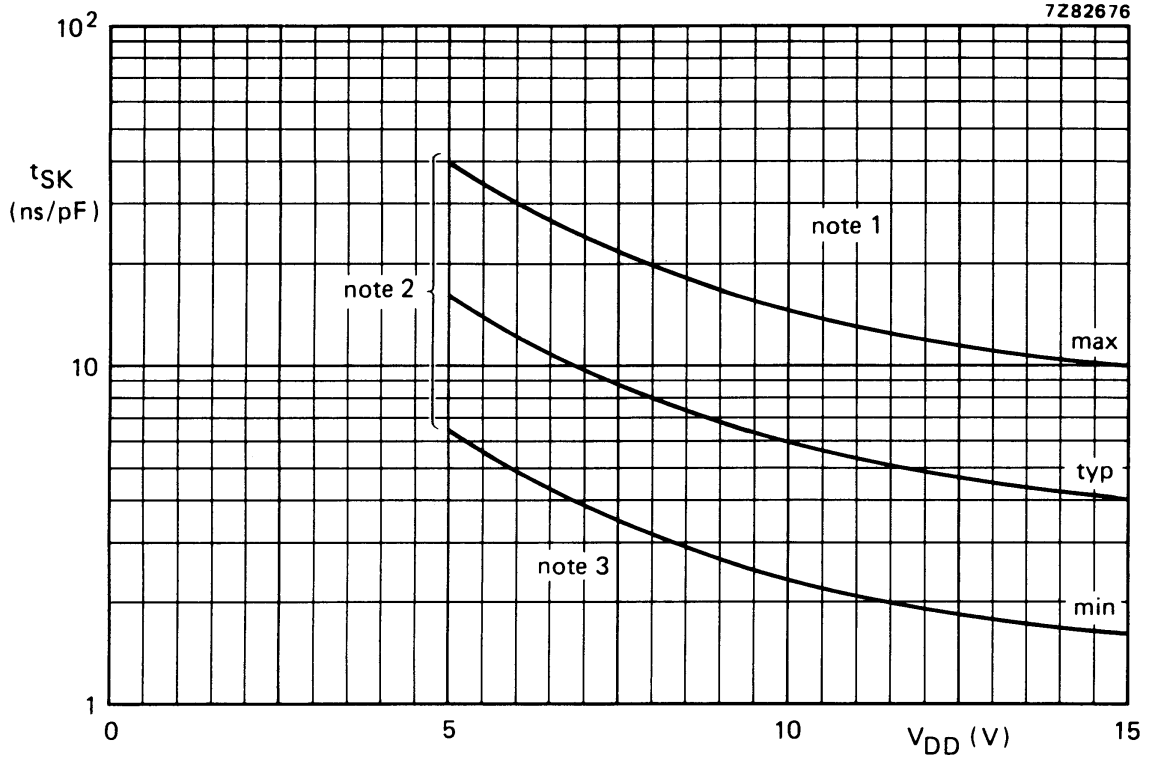

Note 1: Skew in this area results in counted error.

Note 2: Skew in the area between max. and min. curves may or may not result in counted error.

Note 3: Skew in this area results in no error counted.

Fig.5 Typical clock skew as a function of the supply voltage. This graph is accurate for $C_{ext} \geq 100$ pF and $T_{amb} = 25$ °C.

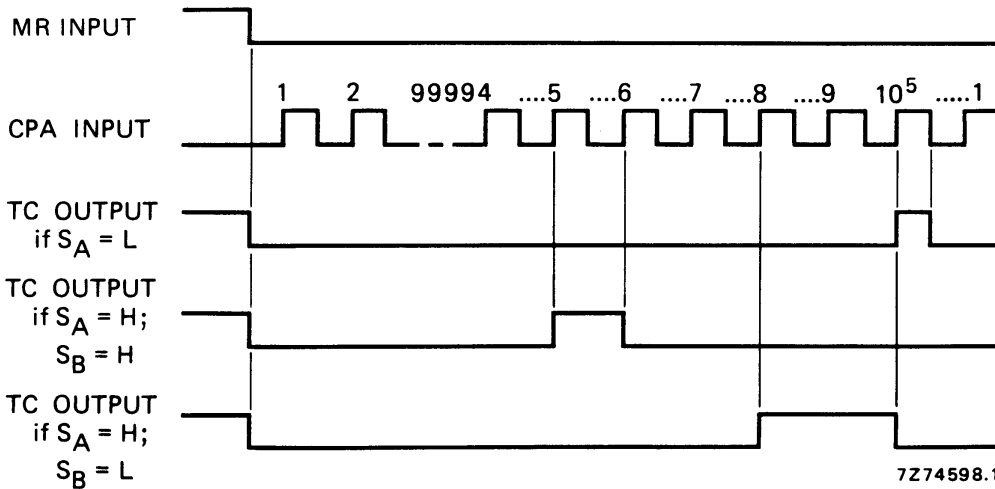
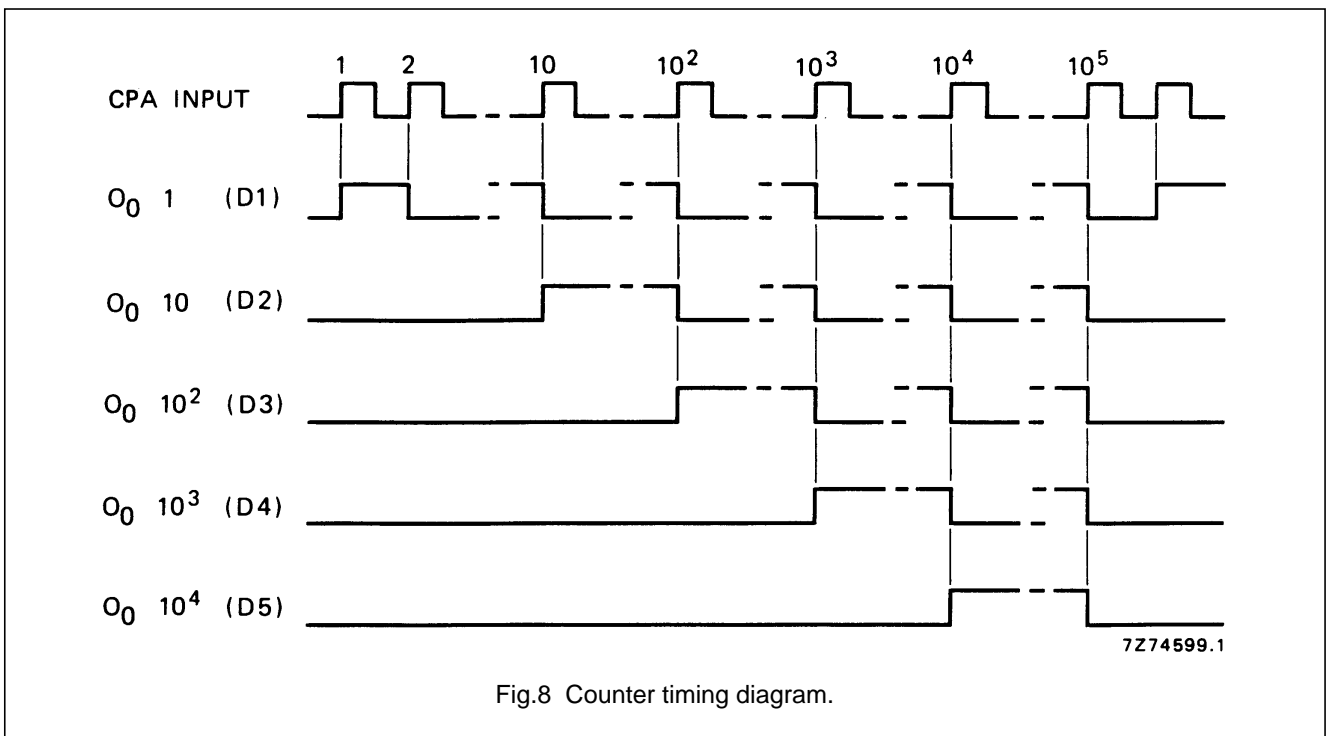
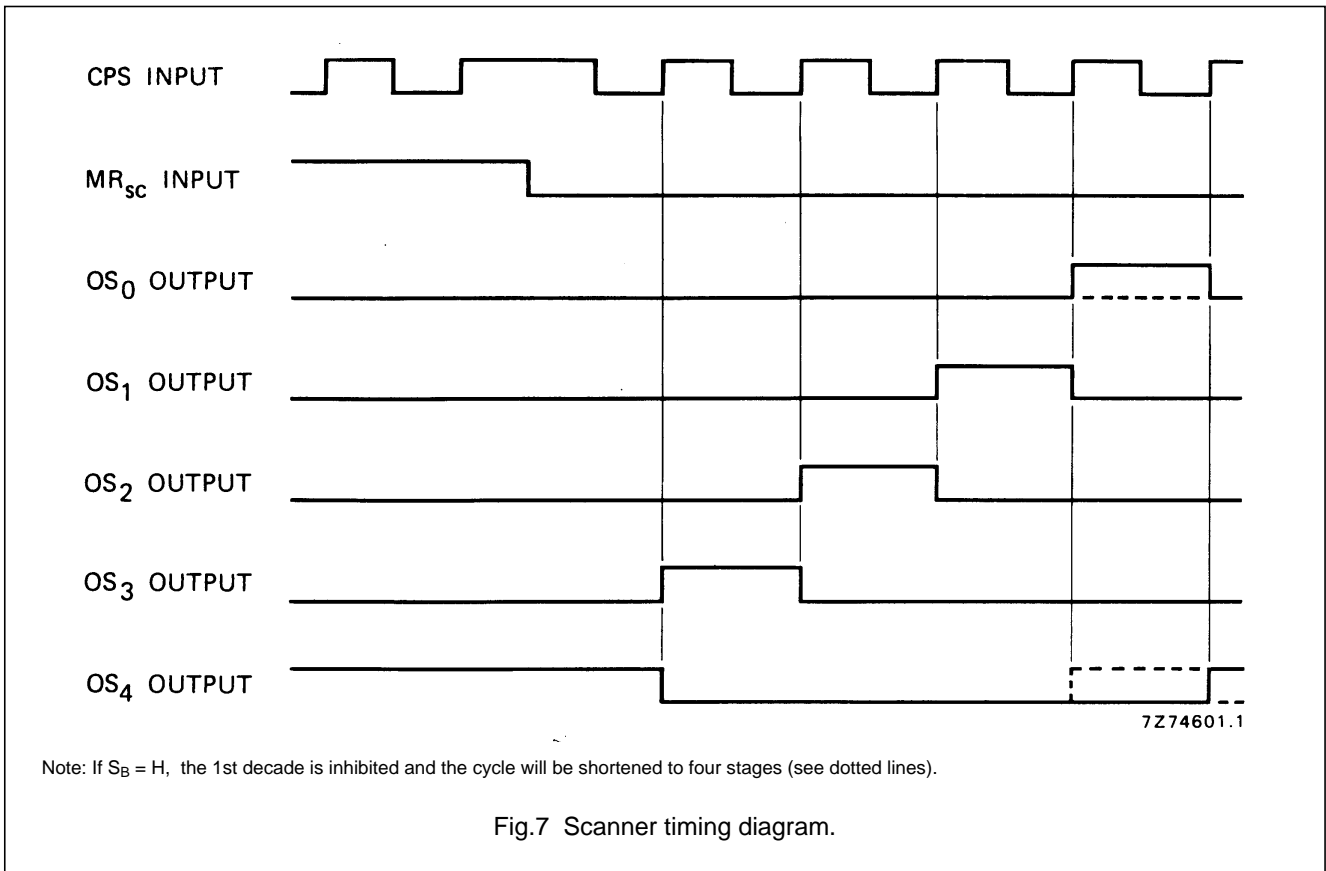

Fig.6 Carry timing diagram.

Real time 5-decade counter

HEF4534B
LSI



Real time 5-decade counter

HEF4534B
LSI

AC CHARACTERISTICS

 $V_{SS} = 0\text{ V}$; $T_{amb} = 25\text{ }^{\circ}\text{C}$; $C_L = 50\text{ pF}$; input transition times $\leq 20\text{ ns}$

	V_{DD} V	SYMBOL	MIN.	TYP.	MAX.	TYPICAL EXTRAPOLATION FORMULA	
Propagation delays							
CPA \rightarrow O_n	5			300	600	ns	283 ns + (0,55 ns/pF) C_L
D1 selected	10	t_{PHL}		130	260	ns	119 ns + (0,23 ns/pF) C_L
HIGH to LOW	15			95	190	ns	87 ns + (0,16 ns/pF) C_L
LOW to HIGH	5			240	480	ns	213 ns + (0,55 ns/pF) C_L
	10	t_{PLH}		100	200	ns	89 ns + (0,23 ns/pF) C_L
	15			75	150	ns	67 ns + (0,16 ns/pF) C_L
CPA \rightarrow O_n	5			550	1100	ns	523 ns + (0,55 ns/pF) C_L
D5 selected	10	t_{PHL}		230	460	ns	219 ns + (0,23 ns/pF) C_L
HIGH to LOW	15			170	340	ns	162 ns + (0,16 ns/pF) C_L
LOW to HIGH	5			550	1100	ns	523 ns + (0,55 ns/pF) C_L
	10	t_{PLH}		230	460	ns	219 ns + (0,23 ns/pF) C_L
	15			170	340	ns	162 ns + (0,16 ns/pF) C_L
CPA \rightarrow TC	5			420	840	ns	393 ns + (0,55 ns/pF) C_L
LOW to HIGH	10	t_{PLH}		190	380	ns	179 ns + (0,23 ns/pF) C_L
	15			140	280	ns	132 ns + (0,16 ns/pF) C_L
MR \rightarrow O_n	5			200	400	ns	173 ns + (0,55 ns/pF) C_L
HIGH to LOW	10	t_{PHL}		85	170	ns	74 ns + (0,23 ns/pF) C_L
	15			60	120	ns	52 ns + (0,16 ns/pF) C_L
MR \rightarrow OER	5			140	280	ns	113 ns + (0,55 ns/pF) C_L
HIGH to LOW	10	t_{PHL}		65	130	ns	54 ns + (0,23 ns/pF) C_L
	15			50	100	ns	42 ns + (0,16 ns/pF) C_L
CPS \rightarrow O_n	5			225	450	ns	198 ns + (0,55 ns/pF) C_L
HIGH to LOW	10	t_{PHL}		95	190	ns	84 ns + (0,23 ns/pF) C_L
	15			70	140	ns	62 ns + (0,16 ns/pF) C_L
LOW to HIGH	5			225	450	ns	198 ns + (0,55 ns/pF) C_L
	10	t_{PLH}		95	190	ns	84 ns + (0,23 ns/pF) C_L
	15			70	140	ns	62 ns + (0,16 ns/pF) C_L
CPS \rightarrow OS_n	5			170	340	ns	143 ns + (0,55 ns/pF) C_L
HIGH to LOW	10	t_{PHL}		70	140	ns	59 ns + (0,23 ns/pF) C_L
	15			50	100	ns	42 ns + (0,16 ns/pF) C_L
CPS \rightarrow OS_n	5			170	340	ns	143 ns + (0,55 ns/pF) C_L
LOW to HIGH	10	t_{PLH}		70	140	ns	59 ns + (0,23 ns/pF) C_L
	15			50	100	ns	42 ns + (0,16 ns/pF) C_L

Real time 5-decade counter

HEF4534B
LSI

	V _{DD} V	SYMBOL	MIN.	TYP.	MAX.	TYPICAL EXTRAPOLATION FORMULA	
Output transition times HIGH to LOW	5	t _{THL}		60	120	ns	10 ns + (1,0 ns/pF) C _L
	10			30	60	ns	9 ns + (0,42 ns/pF) C _L
	15			20	40	ns	6 ns + (0,28 ns/pF) C _L
LOW to HIGH	5	t _{TLH}		60	120	ns	10 ns + (1,0 ns/pF) C _L
	10			30	60	ns	9 ns + (0,42 ns/pF) C _L
	15			20	40	ns	6 ns + (0,28 ns/pF) C _L

AC CHARACTERISTICS

V_{SS} = 0 V; T_{amb} = 25 °C; C_L = 50 pF; input transition times ≤ 20 ns

	V _{DD} V	SYMBOL	MIN.	TYP.	MAX.	
3-state propagation delays						
Output disable times						
$\overline{EO} \rightarrow O_n$;	5	t _{PHZ}		30	60	ns
$\overline{EOS} \rightarrow OS_n$	10			25	50	ns
HIGH	15			20	40	ns
LOW	5	t _{PLZ}		40	80	ns
	10			25	50	ns
	15			20	40	ns
Output enable times						
$\overline{EO} \rightarrow O_n$;	5	t _{PZH}		35	70	ns
$\overline{EOS} \rightarrow OS_n$	10			20	40	ns
HIGH	15			15	30	ns
LOW	5	t _{PZL}		50	100	ns
	10			25	50	ns
	15			15	30	ns
Minimum clock pulse width; CPA, CPS	5	t _{WCPH}	70	35		ns
	10			40	20	ns
HIGH	15			30	15	ns
Minimum reset pulse width; MR, MR _{sc}	5	t _{WMRH}	90	45		ns
	10			60	30	ns
HIGH	15			40	20	ns
Recovery time for MR	5	t _{RMR}	120	60		ns
	10			60	30	ns
	15			50	25	ns
Recovery time for MR _{sc}	5	t _{RMR}	60	30		ns
	10			40	20	ns
	15			30	15	ns

Real time 5-decade counter

HEF4534B
LSI

	V _{DD} V	SYMBOL	MIN.	TYP.	MAX.	
Maximum clock pulse frequency	5	f _{max}	2,5	5		MHz
CPA and CPS	10		6	12		MHz
	15		8	16		MHz

	V _{DD} V	TYPICAL FORMULA FOR P (μW)	
Dynamic power dissipation per package (P) ⁽¹⁾	5	$1\ 100 f_i + \sum (f_o C_L) \times V_{DD}^2$	where f _i = input freq. (MHz) f _o = output freq. (MHz) C _L = load cap. (pF) ∑ (f _o C _L) = sum of outputs V _{DD} = supply voltage (V)
	10	$4\ 800 f_i + \sum (f_o C_L) \times V_{DD}^2$	
	15	$12\ 000 f_i + \sum (f_o C_L) \times V_{DD}^2$	

Note

1. C_{ext} = 0.

Real time 5-decade counter

HEF4534B
LSI

APPLICATION INFORMATION

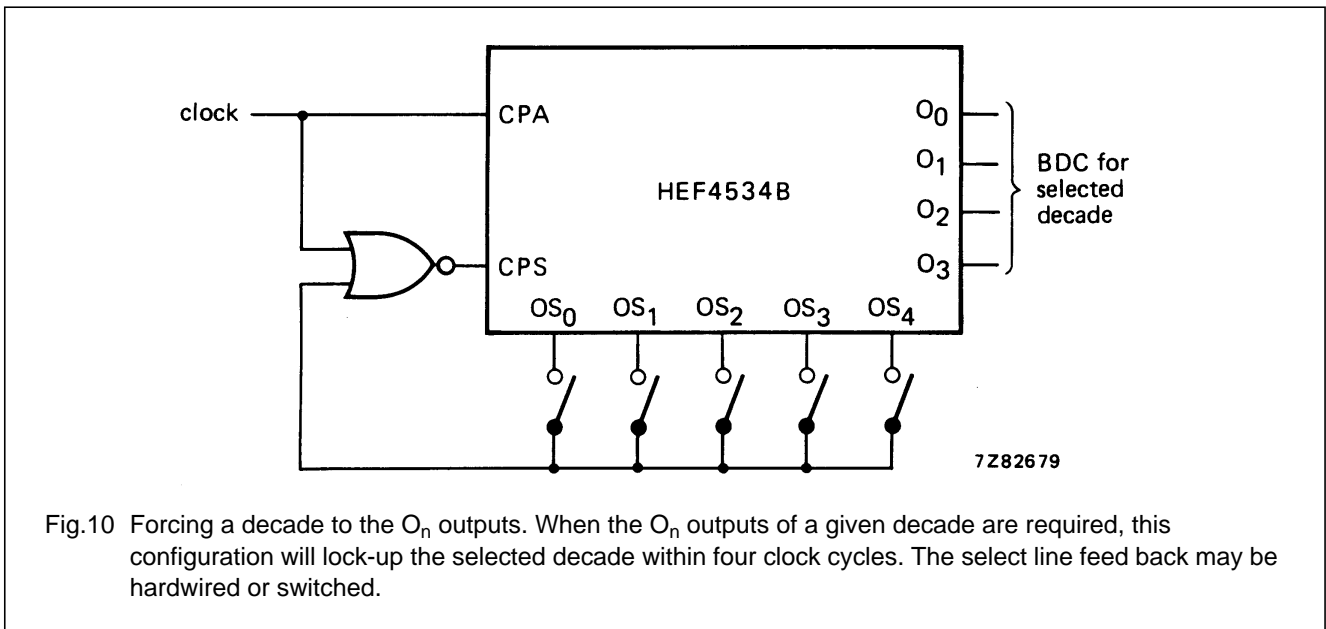
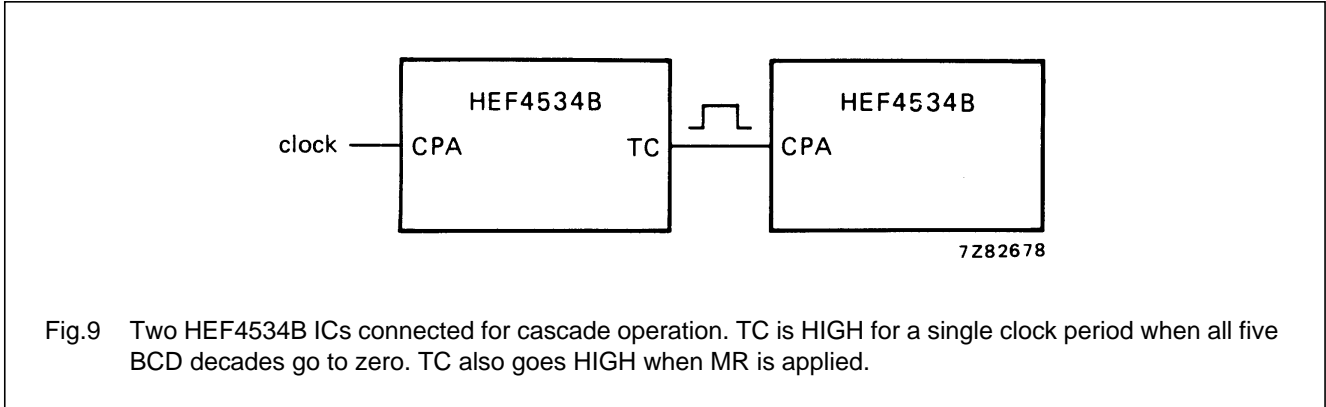



LittleDiode supplies new, hard to find or obsolete electronic components and semiconductors all over the world.

With over two million different components listed you are sure to find the part you need.

Feel free to visit us today at our online store:

LittleDiode.com

Looking forward to providing you with the best possible service.