

GENERAL DESCRIPTION

The HI-8281 device from Holt Integrated Circuits is a silicon gate CMOS device for interfacing a 16-bit parallel data bus directly to the ARINC 429 serial bus. The device provides two receivers, an independent transmitter and line driver capability in a single package. The receiver input circuitry and logic are designed to meet the ARINC 429 specifications for loading, level detection, timing, and protocol. The transmitter section provides the ARINC 429 communication protocol and the line driver circuits provide the ARINC 429 output levels.

The 16-bit parallel data bus exchanges the 32-bit ARINC data word in two steps when either loading the transmitter or interrogating the receivers. The data bus interfaces with CMOS and TTL.

Timing of all the circuitry begins with the master clock input, CLK. For ARINC 429 applications, the master clock frequency is 1 MHz.

Each independent receiver monitors the data stream with a sampling rate 10 times the data rate. The sampling rate is software selectable at either 1MHz or 125KHz. The results of a parity check are available as the 32nd ARINC bit. The HI-8281 examines the null and data timings and will reject erroneous patterns. For example, with a 125 KHz clock selection, the data frequency must be between 10.4 KHz and 15.6 KHz.

The transmitter has a First In, First Out (FIFO) memory to store 8 ARINC words for transmission. The data rate of the transmitter is software selectable by dividing the master clock, CLK, by either 10 or 80. The master clock is used to set the timing of the ARINC transmission within the required resolution.

APPLICATIONS

- Avionics data communication
- Serial to parallel conversion
- Parallel to serial conversion

FEATURES

- ARINC specification 429 compatible
- Direct receiver and transmitter interface to ARINC bus in a single device.
- 16-Bit parallel data bus.
- Timing control 10 times the data rate
- Selectable data clocks
- Receiver error rejection per ARINC specification 429
- Automatic transmitter data timing
- Self test mode
- Parity functions
- Low power
- Industrial & full military temperature ranges

PIN CONFIGURATION (Top View)

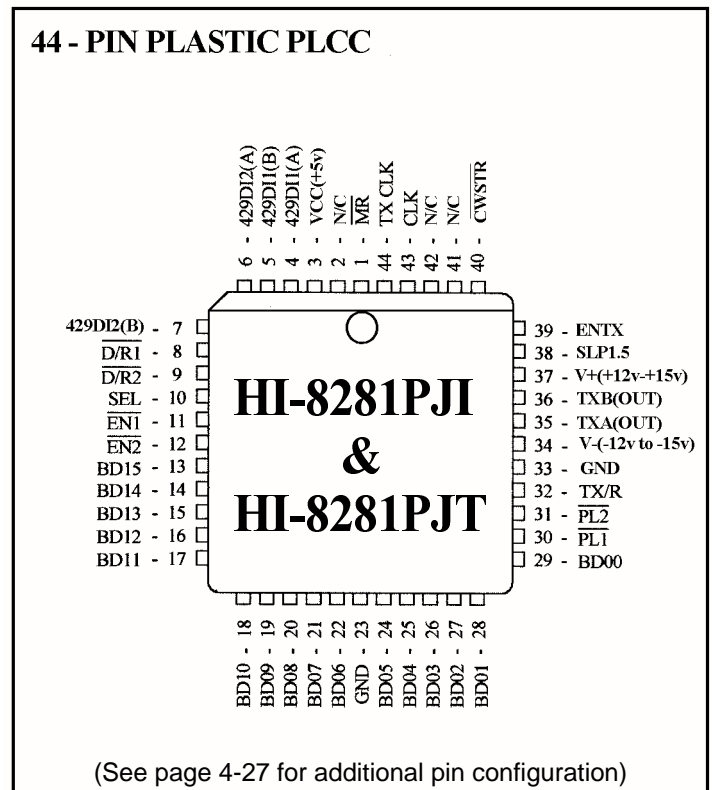

PIN DESCRIPTION

| SIGNAL | FUNCTION | DESCRIPTION |
|--------------------|----------|---|
| VCC | POWER | +5V \pm 5% |
| V+ | POWER | +12V \pm 5% or +15V \pm 10% |
| V- | POWER | -12V \pm 5% or -15V \pm 10% |
| 429DI1 (A) | INPUT | ARINC receiver 1 positive input |
| 429DI1 (B) | INPUT | ARINC receiver 1 negative input |
| 429DI2 (A) | INPUT | ARINC receiver 2 positive input |
| 429DI2 (B) | INPUT | ARINC receiver 2 negative input |
| $\overline{D/R1}$ | OUTPUT | Receiver 1 data ready flag |
| $\overline{D/R2}$ | OUTPUT | Receiver 2 data ready flag |
| SEL | INPUT | Receiver data byte selection (0 = BYTE 1) (1 = BYTE 2) |
| $\overline{EN1}$ | INPUT | Data Bus control, enables receiver 1 data to outputs |
| $\overline{EN2}$ | INPUT | Data Bus control, enables receiver 2 data to outputs if $\overline{EN1}$ is high |
| BD15 | I/O | Data Bus |
| BD14 | I/O | Data Bus |
| BD13 | I/O | Data Bus |
| BD12 | I/O | Data Bus |
| BD11 | I/O | Data Bus |
| BD10 | I/O | Data Bus |
| BD09 | I/O | Data Bus |
| BD08 | I/O | Data Bus |
| BD07 | I/O | Data Bus |
| BD06 | I/O | Data Bus |
| GND | POWER | 0 V - both pins must be connected |
| BD05 | I/O | Data Bus |
| BD04 | I/O | Data Bus |
| BD03 | I/O | Data Bus |
| BD02 | I/O | Data Bus |
| BD01 | I/O | Data Bus |
| BD00 | I/O | Data Bus |
| TX/R | OUTPUT | Transmitter ready flag. Goes low when ARINC word loaded into FIFO. Goes high After transmission and FIFO empty. |
| $\overline{PL1}$ | INPUT | Latch enable for byte 1 entered from data bus to transmitter FIFO. |
| $\overline{PL2}$ | INPUT | Latch enable for byte 2 entered from data bus to transmitter FIFO. Must follow $\overline{PL1}$. |
| TXA(OUT) | OUTPUT | Line driver output - A side |
| TXB(OUT) | OUTPUT | Line driver output - B side |
| ENTX | INPUT | Enable Transmission |
| \overline{CWSTR} | INPUT | Clock for control word register |
| CLK | INPUT | Master Clock input |
| TX CLK | OUTPUT | Transmitter Clock equal to Master Clock (CLK), divided by either 10 or 80. |
| \overline{MR} | INPUT | Master Reset, active low |
| SLP1.5 | INPUT | Logic input to control the slope of the differential output signal. HIGH = 1.5 μ s |

FUNCTIONAL DESCRIPTION

CONTROL WORD REGISTER

The HI-8282 contains 10 data flip flops whose D inputs are connected to the data bus and clocks connected to CWSTR. Each flip flop provides options to the user as follows:

| DATA BUS PIN | FUNCTION | CONTROL | DESCRIPTION |
|--------------|----------------------|--------------------|--|
| BDO5 | SELF TEST | 0 = ENABLE | If enabled, an internal connection is made passing 429DO and 429DO to the receiver logic inputs |
| BDO6 | RECEIVER 1 DECODER | 1 = ENABLE | If enabled, ARINC bits 9 and 10 must match the next two control word bits |
| BDO7 | - | - | If Receiver 1 Decoder is enabled, the ARINC bit 9 must match this bit |
| BDO8 | - | - | If Receiver 1 Decoder is enabled, the ARINC bit 10 must match this bit |
| BDO9 | RECEIVER 2 DECODER | 1 = ENABLE | If enabled, ARINC bits 9 and 10 must match the next two control word bits |
| BD10 | - | - | If Receiver 2 Decoder is enabled, then ARINC bit 9 must match this bit |
| BD11 | - | - | If Receiver 2 Decoder is enabled, then ARINC bit 10 must match this bit |
| BD12 | INVERT XMTR PARITY | 1 = ENABLE | Logic 0 enables normal odd parity and Logic 1 enables even parity output in transmitter 32nd bit |
| BD13 | XMTR DATA CLK SELECT | 0 = ÷10 1 = ÷80 | CLK is divided either by 10 or 80 to obtain XMTR data clock |
| BD14 | RCVR DTA CLK SELECT | 0 = ÷10 1 = ÷80 | CLK is divided either by 10 or 80 to obtain RCVR data clock |

ARINC 429 DATA FORMAT

The following table shows the bit positions in exchanging data with the receiver or the transmitter. ARINC bit 1 is the first bit transmitted or received.

| BYTE 1 | | | | | | | | | | | | | | | | |
|-----------|-------|-------|-------|-------|-------|-------|-------|-------|-------|-------|-------|-------|-------|-------|-------|-------|
| DATA BUS | BD 15 | BD 14 | BD 13 | BD 12 | BD 11 | BD 10 | BD 09 | BD 08 | BD 07 | BD 06 | BD 05 | BD 04 | BD 03 | BD 02 | BD 01 | BD 00 |
| ARINC BIT | 13 | 12 | 11 | 10 | 9 | 31 | 30 | 32 | 1 | 2 | 3 | 4 | 5 | 6 | 7 | 8 |

| BYTE 2 | | | | | | | | | | | | | | | | |
|-----------|-------|-------|-------|-------|-------|-------|-------|-------|-------|-------|-------|-------|-------|-------|-------|-------|
| DATA BUS | BD 15 | BD 14 | BD 13 | BD 12 | BD 11 | BD 10 | BD 09 | BD 08 | BD 07 | BD 06 | BD 05 | BD 04 | BD 03 | BD 02 | BD 01 | BD 00 |
| ARINC BIT | 29 | 28 | 27 | 26 | 25 | 24 | 23 | 22 | 21 | 20 | 19 | 18 | 17 | 16 | 15 | 14 |

THE RECEIVERS

ARINC BUS INTERFACE

Figure 1 shows the input circuit for each receiver. The ARINC 429 specification requires the following detection levels:

| STATE | DIFFERENTIAL VOLTAGE |
|-------|--------------------------|
| ONE | +6.5 Volts to +13 Volts |
| NULL | +2.5 Volts to -2.5 Volts |
| ZERO | -6.5 Volts to -13 Volts |

The HI-8282 guarantees recognition of these levels with a common mode Voltage with respect to GND less than ±4V for the worst case condition (4.75V supply and 13V signal level).

The tolerances in the design guarantee detection of the above levels, so the actual acceptance ranges are slightly larger. If the ARINC signal is out of the actual acceptance ranges, including the nulls, the chip rejects the data.

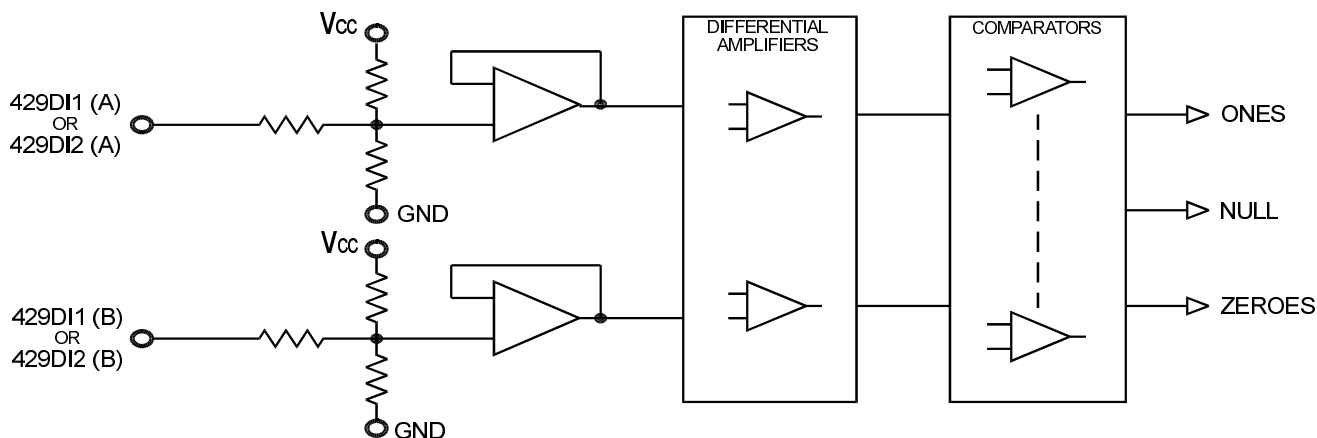

FIGURE 1. ARINC RECEIVER INPUT

FUNCTIONAL DESCRIPTION (con't)

RECEIVER LOGIC OPERATION

Figure 2 shows a block diagram of the logic section of each receiver.

BIT TIMING

The ARINC 429 specification contains the following timing specification for the received data:

| | <u>HIGH SPEED</u> | <u>LOW SPEED</u> |
|------------------------|-------------------|-------------------|
| BIT RATE | 100K BPS ± 1% | 12K - 14.5K BPS |
| PULSE RISE TIME | 1.5 ± 0.5 μsec | 10 ± 5 μsec |
| PULSE FALL TIME | 1.5 ± 0.5 μsec | 10 ± 5 μsec |
| PULSEWIDTH | 5 μsec ± 5% | 34.5 to 41.7 μsec |

Again the HI-8282 accepts signals that meet these specifications and rejects outside the tolerances. The way the logic operation achieves this is described below:

1. Key to the performance of the timing checking logic is an accurate 1MHz clock source. Less than 0.1% error is recommended.
2. The sampling shift registers are 10 bits long and must show three consecutive Ones, Zeros or Nulls to be considered valid data. Additionally, for data bits, the One or Zero in the upper bits of the sampling shift registers must be followed by a Null in the lower bits within the data bit time. For a Null in the word gap, three consecutive Nulls must be found in both the upper and lower bits of the sampling shift register. In this manner the minimum pulse width is guaranteed.

3. Each data bit must follow its predecessor by not less than 8 samples and no more than 12 samples. In this manner the bit rate is checked. With exactly 1MHz input clock frequency, the acceptable data bit rates are as follows:

| | <u>HIGH SPEED</u> | <u>LOW SPEED</u> |
|--------------------------|-------------------|------------------|
| DATA BIT RATE MIN | 83K BPS | 10.4K BPS |
| DATA BIT RATE MAX | 125K BPS | 15.6K BPS |

4. The WordGap timer samples the Null shift register every 10 input clocks (80 for low speed) after the last data bit of a Valid reception. If the Null is present, the WordGap counter is incremented. A count of 3 will enable the next reception.

RECEIVER PARITY

The receiver parity circuit counts Ones received, including the parity bit, ARINC bit 32. If the result is odd, then "0" will appear in the 32nd bit.

RETRIEVING DATA

Once 32 valid bits are recognized, the receiver logic generates an End of Sequence (EOS). If the receiver decoder is enabled and the 9th and 10th ARINC bits match the control word program bits or if the receiver decoder is disabled, then EOS clocks the data ready flag flip flop to a "1", D/R1 or D/R2 (or both) will go low. The data flag for a receiver will remain low until after both ARINC bytes from that receiver are retrieved. This is accomplished by activating EN with SEL, the byte selector, low to retrieve the first byte and activating EN with SEL high to retrieve the second byte. EN1 retrieves data from receiver 1 and EN2 retrieves data from receiver 2.

If another ARINC word is received, and a new EOS occurs before the two bytes are retrieved, the data is overwritten by the new word.

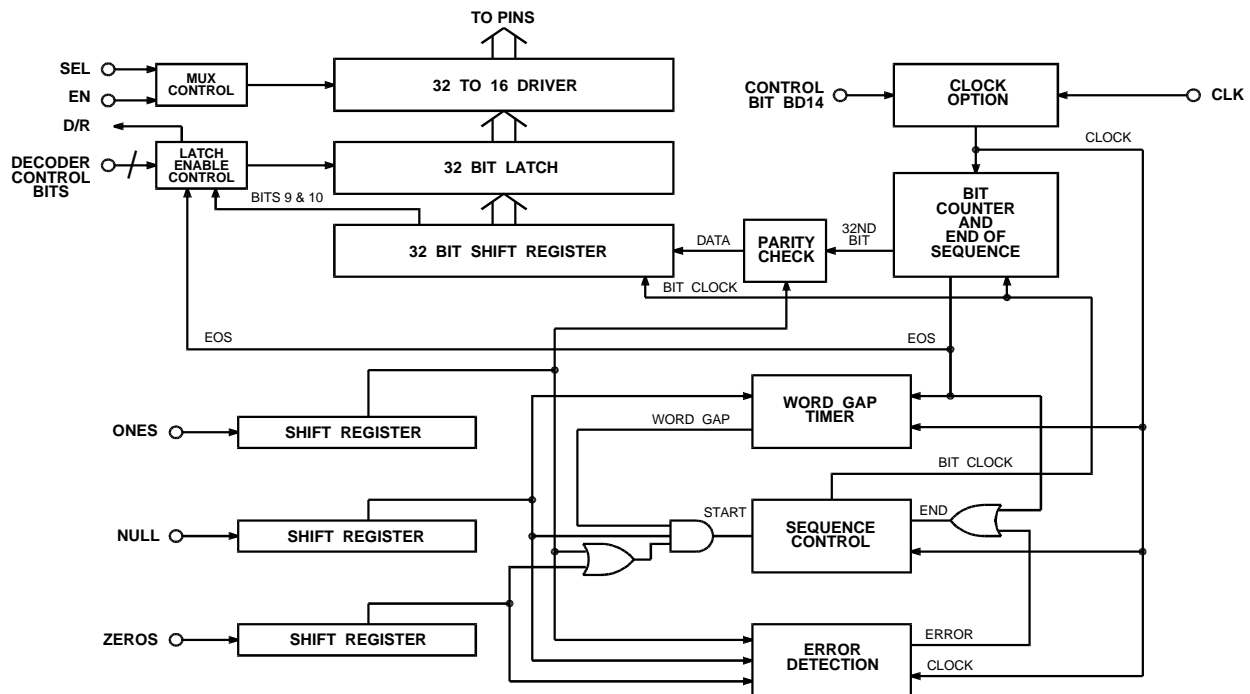

FIGURE 2. RECEIVER BLOCK DIAGRAM

FUNCTIONAL DESCRIPTION (con't)

TRANSMITTER

A block diagram of the transmitter section is shown in Figure 3.

FIFO OPERATION

The FIFO is loaded sequentially by first pulsing PL1 to load byte 1 and then PL2 to load byte 2. The control logic automatically loads the 31 bit word in the next available position of the FIFO. If TX/R, the transmitter ready flag is high (FIFO empty), then 8 words, each 31 bits long, may be loaded. If TX/R is low, then only the available positions may be loaded. If all 8 positions are full, the FIFO ignores further attempts to load data.

DATA TRANSMISSION

When ENTX goes high, enabling transmission, the FIFO positions are incremented with the top register loading into the data transmission shift register. Within 2.5 data clocks the first data bit appears at either 429DO or 429DO. The 31 bits in the data transmission shift register are presented sequentially to the outputs in the ARINC 429 format with the following timing:

| | <u>HIGH SPEED</u> | <u>LOW SPEED</u> |
|---------------------|-------------------|------------------|
| ARINC DATA BIT TIME | 10 Clocks | 80 Clocks |
| DATA BIT TIME | 5 Clocks | 40 Clocks |
| NULL BIT TIME | 5 Clocks | 40 Clocks |
| WORD GAP TIME | 40 Clocks | 320 Clocks |

The word counter detects when all loaded positions are transmitted and sets the transmitter ready flag, TX/R, high.

TRANSMITTER PARITY

The parity generator counts the ONES in the 31-bit word. If the BD12 control word bit is set low, the 32nd bit transmitted will make parity odd. If the control bit is high the parity is even.

SELF TEST

If the BD05 control word bit is set low, 429DO or 429DO become inputs to the receiver bypassing the interface circuitry.

SYSTEM OPERATION

The two receivers are independent of the transmitter. Therefore, control of data exchanges are strictly at the option of the user. The only restrictions are:

1. The received data may be overwritten if not retrieved within one ARINC word cycle.
2. The FIFO can store 8 words maximum and ignores attempts to load addition data if full.
3. Byte 1 of the transmitter data must be loaded first.
4. Either byte of the received data may be retrieved first. Both bytes must be retrieved to clear the data ready flag.
5. After ENTX, transmission enable ,goes high it cannot go low until TX/R, transmitter readyflag, goes high. Otherwise, one ARINC word is lost during transmission.

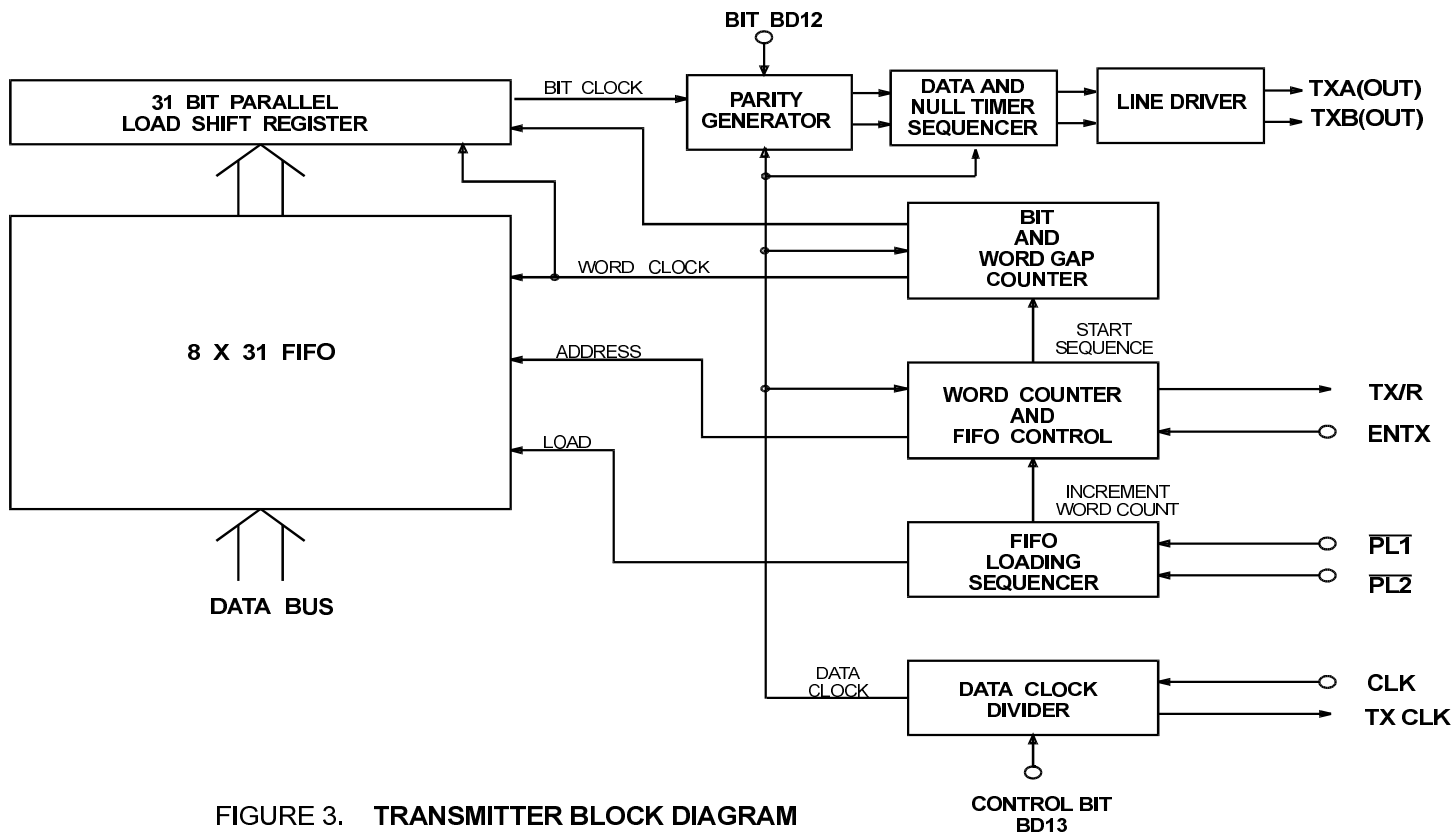

FIGURE 3. TRANSMITTER BLOCK DIAGRAM

FUNCTIONAL DESCRIPTION (con't)

LINE DRIVER OPERATION

The line driver in the HI-8281 is designed to directly drive the ARINC 429 bus. The two ARINC outputs (TXA(OUT) and TXB(OUT)) provide a differential voltage to produce a +10 volt One, a -10 volt Zero, and a 0 volt Null. The device incorporates on board zeners to translate internal CMOS levels to ARINC specified amplitudes. A logic input (SLP1.5) is provided to control the slope of the differential output signal. No additional hardware is required to control the slope. A HIGH on SLP1.5 causes a slope of 1.5 μ s on the ARINC outputs; a LOW on SLP1.5 causes a slope of 10 μ s. Timing is set by on-chip resistor and capacitor and tested to be within ARINC requirements. The HI-8281 has 37.5 ohms in series with each line driver output.

REPEATER OPERATION

Repeater mode of operation allows a data word that has been received by the HI-8281 to be placed directly into its FIFO for transmission. Repeater operation is similar to normal receiver operation. In normal operation, either byte of a received data word may be read from the receiver latches first by use of SEL input. During repeater operation however, the lower byte of the data word must be read first. This is necessary because, as the data is being read, it is also being loaded into the FIFO and the transmitter FIFO is always loaded with the lower byte of the data word first. Signal flow for repeater operation is shown in the Timing Diagrams section.

TIMING DIAGRAMS

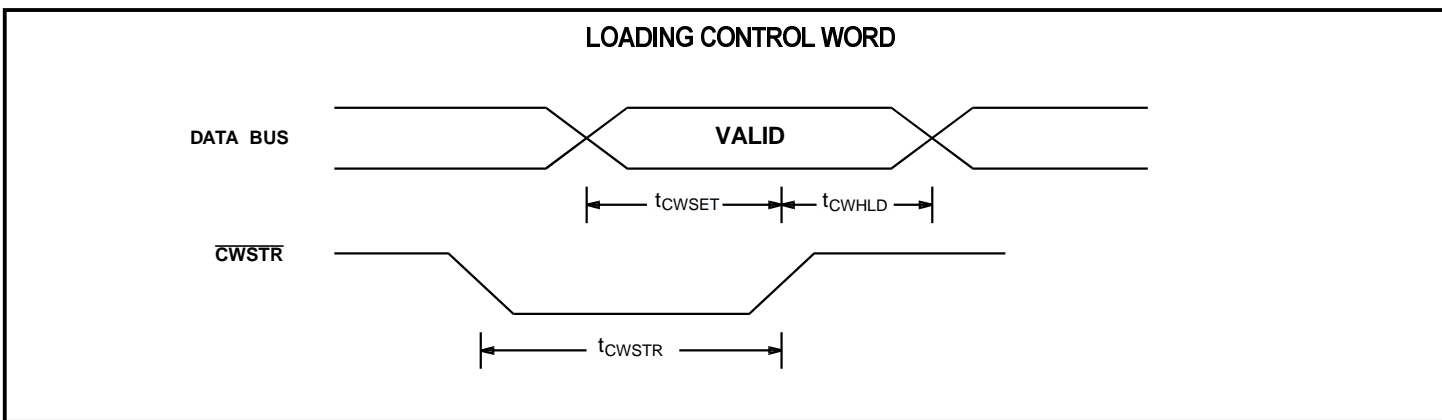
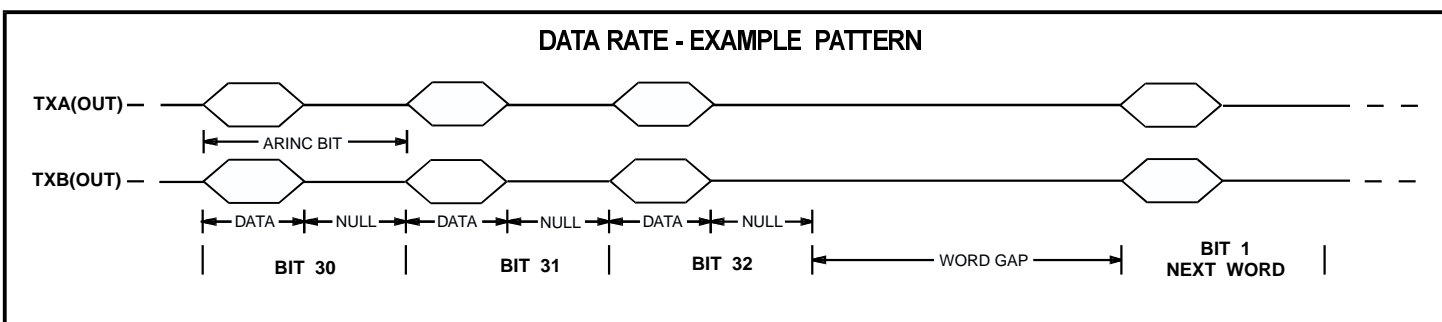

TIMING DIAGRAMS (con't)

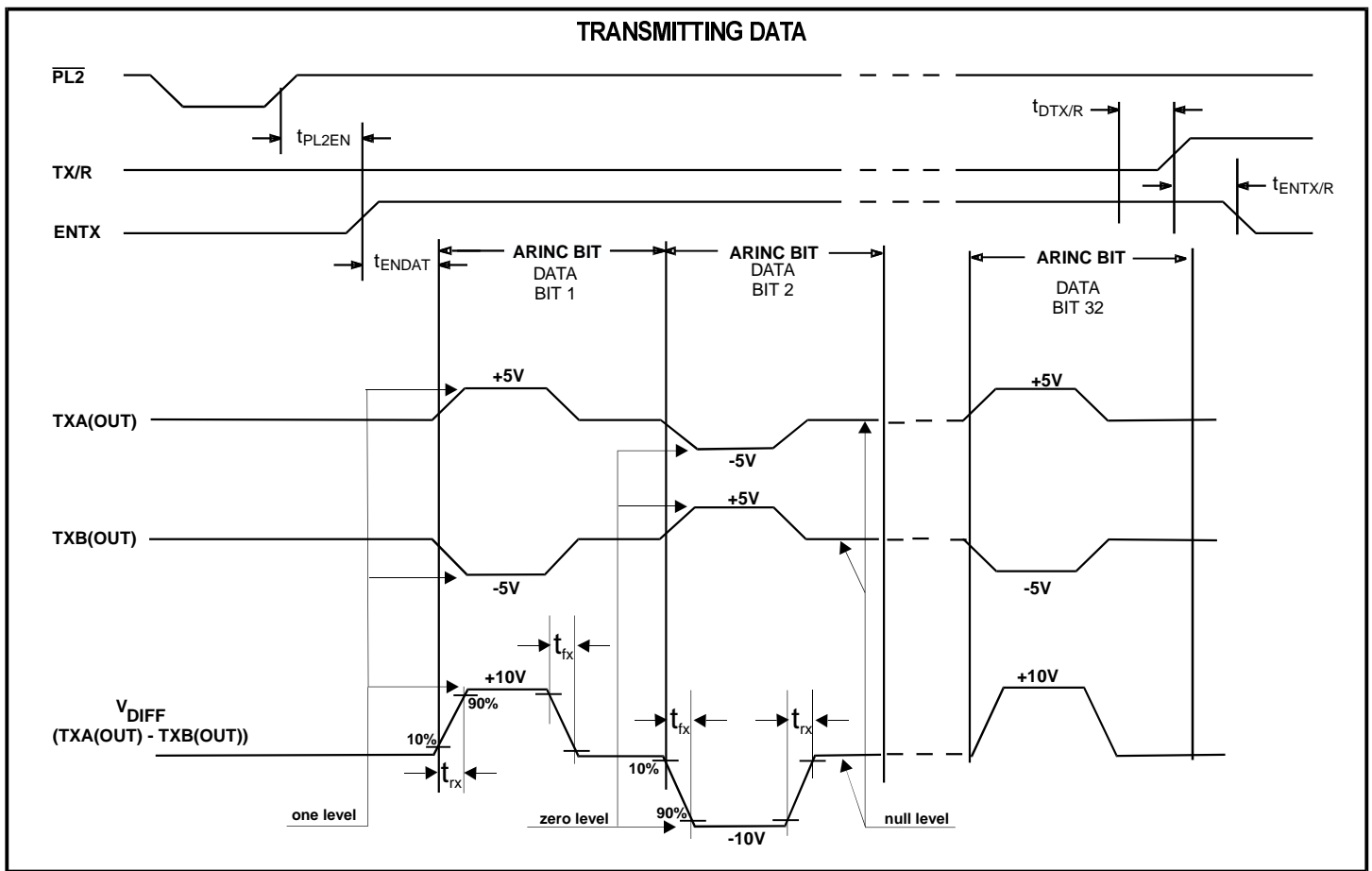
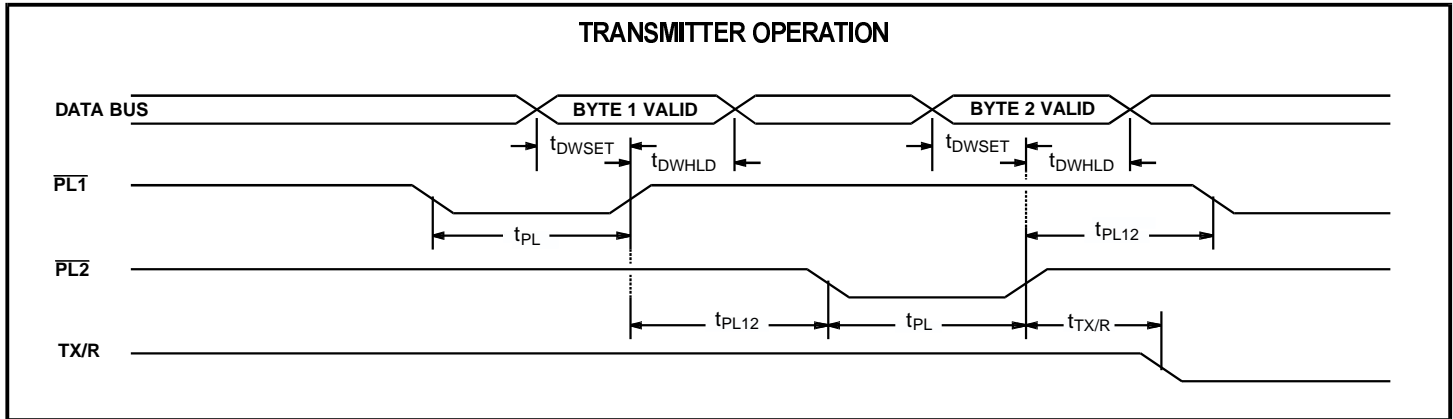

TIMING DIAGRAMS (con't)

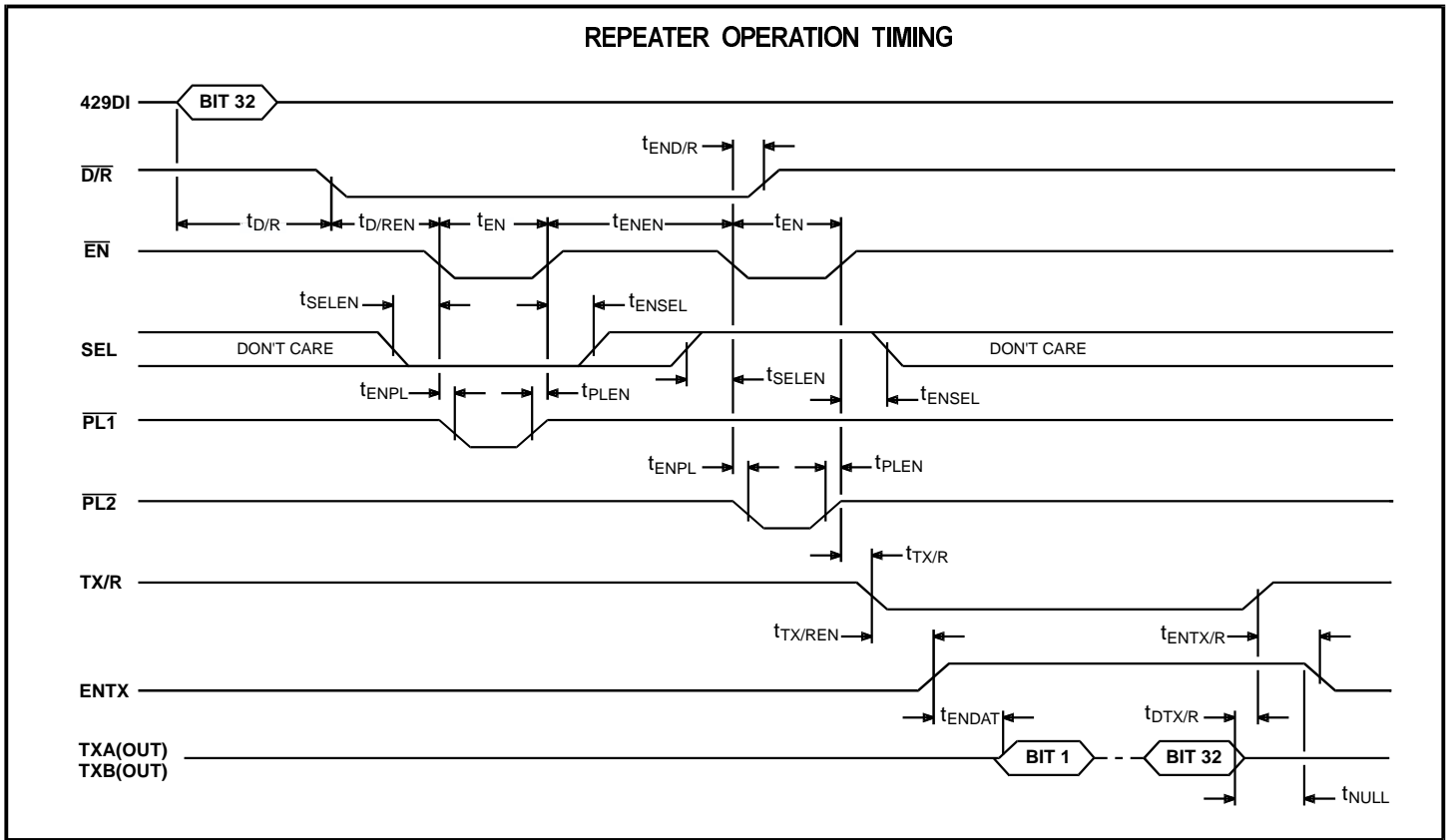

ABSOLUTE MAXIMUM RATINGS

| | |
|--|--|
| Supply Voltages V _{CC} -0.3V to +7V V ₊ 20V V ₋ -20V | Power Dissipation at 25C Plastic PLCC 1.5 W, derate 10mW/°C Ceramic J-LEAD CERQUAD..... 1.0 W, derate 7mW/°C |
| Voltage at pins 4, 5, 6 and 7 -29V to +29V | DC Current Drain per pin ±10mA |
| Voltage at pin 38 -0.3 to V ₊ +0.3V | Storage Temperature Range: -65°C to +150°C |
| Voltage at any other pin -0.3V to V _{CC} +0.3V | Operating Temperature Range: (Industrial) -40°C to +85°C (Military) -55°C to +125°C |

NOTE: Stresses above those listed under "Absolute Maximum Ratings" may cause permanent damage to the device. These are stress ratings only. Functional operation of the device at these or any other conditions above those indicated in the operational sections of the specifications is not implied. Exposure to absolute maximum rating conditions for extended periods may affect device reliability.

DC ELECTRICAL CHARACTERISTICS

V_{CC} = 5V ±5%, V₊ = 12V to 15V, V₋ = -12V to -15V, GND = 0V, T_A = Operating Temperature Range (unless otherwise specified).

| PARAMETER | SYMBOL | CONDITIONS | LIMITS | | | UNIT | |
|---|--|------------------|--|-------|-------|----------------|----------------------|
| | | | MIN | TYP | MAX | | |
| ARINC INPUTS - Pins 4, 5, 6 & 7 | | | | | | | |
| Differential Input Voltage: | ONE | V _{IH} | Pins 4 to 5, 6 to 7: Common mode voltage less than ±4V with respect to GND | 6.5 | 10.0 | 13.0 | V |
| | ZERO | V _{IL} | | -13.0 | -10.0 | -6.5 | V |
| | NULL | V _{NUL} | | -2.5 | 0 | 2.5 | V |
| Input Resistance: | Differential To GND To V _{CC} | R _I | | 12 | 27 | | KΩ |
| | | R _G | | 12 | | | KΩ |
| | | R _H | | 12 | | | KΩ |
| Input Current: | Input Sink Input Source | I _{IH} | | -450 | | 200 | μA |
| | | I _{IL} | | | | | μA |
| Input Capacitance: (Guaranteed but not tested) | Differential To GND To V _{CC} | C _I | Pins 4 to 5, 6 to 7 | | | 20 | pF |
| | | C _G | | | | 20 | pF |
| | | C _H | | | | 20 | pF |
| BI-DIRECTIONAL INPUTS - Pins 13 - 22, 24 - 29 | | | | | | | |
| Input Voltage: | Input Voltage HI | V _{IH} | | 2.1 | | 0.7 | V |
| | Input Voltage LO | V _{IL} | | | | | V |
| Input Current: | Input Sink Input Source | I _{IH} | | -1.5 | | 1.5 | μA |
| | | I _{IL} | | | | | μA |
| OTHER INPUTS - Pins 1, 8 - 12, 30, 31, 39, 40 & 43 | | | | | | | |
| Input Voltage: | Input Voltage HI | V _{IH} | | 3.5 | | 0.7 | V |
| | Input Voltage LO | V _{IL} | | | | | V |
| Input Current: | Input Sink Input Source | I _{IH} | | -20 | | 10 | μA |
| | | I _{IL} | | | | | μA |
| INPUT - SLP1.5, PIN 38 | | | | | | | |
| Input Voltage | Input Voltage HI | V _{IH} | | 2.1 | - | V ₊ | V |
| | Input Voltage LO | V _{IL} | | | | | - |
| Input Current | Input Sink Input Source | I _{IH} | V _{IN} = 0V | | | 0.1 | μA |
| | | I _{IL} | | | | | V _{IN} = 5V |

DC ELECTRICAL CHARACTERISTICS (con't)

V_{CC} = 5V ±5%, V₊ = 12V to 15V, V₋ = -12V to -15V, GND = 0V, T_A = Operating Temperature Range (unless otherwise specified).

| PARAMETER | SYMBOL | CONDITIONS | LIMITS | | | UNIT |
|---|--|---|--|------------|--------------|----------|
| | | | MIN | TYP | MAX | |
| ARINC OUTPUTS - Pins 35 & 36 | | | | | | |
| ARINC output voltage One or zero Null | V _{DOUT} V _{NOUT} | no load and magnitude at pin " " " " " " | 4.50 -0.25 | 5.00 | 5.50 0.25 | V V |
| ARINC output current | I _{OUT} | | 80 | | | mA |
| OTHER OUTPUTS - Pins 13-22, 24-29, 32 & 34 | | | | | | |
| Output Voltage: Logic "1" Output Voltage Logic "0" Output Voltage | V _{OH} V _{OL} | I _{OH} = -1.5mA I _{OL} = 1.8mA | 2.7 | | 0.4 | V V |
| Output Current: (Bi-directional Pins) | Output Sink Output Source | I _{OL} I _{OH} | V _{OUT} = 0.4V V _{OUT} = V _{CC} - 0.4V | 3.0 1.5 | | mA mA |
| Output Current: (All Other Outputs) | Output Sink Output Source | I _{OL} I _{OH} | V _{OUT} = 0.4V V _{OUT} = V _{CC} - 0.4V | 3.6 1.5 | | mA mA |
| Output Capacitance: | C _O | | | 15 | | pF |
| Operating Supply Current | | | | | | |
| V _{CC} , Pin 3: | I _{CC1} | | | | 20 | mA |
| V ₊ , Pin 37: | I _{DD1} | | | | 16 | mA |
| V ₋ , Pin 34: | I _{EE1} | | | | 16 | mA |

AC ELECTRICAL CHARACTERISTICS

V_{cc} = 5V, V₊ = 12V to 15V, V₋ = -12V to -15V, GND = 0V, TA = Oper. Temp. Range and f_{clk} = 1MHz ±0.1% with 60/40 duty cycle

| PARAMETER | SYMBOL | LIMITS | | | UNITS | |
|--|---------------------|-----------------|-----|-----|-------|----|
| | | MIN | TYP | MAX | | |
| CONTROL WORD TIMING | | | | | | |
| Pulse Width - \overline{CWSTR} | t _{CWSTR} | 130 | | | ns | |
| Setup - DATA BUS Valid to \overline{CWSTR} HIGH | t _{CWSET} | 140 | | | ns | |
| Hold - \overline{CWSTR} HIGH to DATA BUS Hi-Z | t _{CWHLd} | 0 | | | ns | |
| RECEIVER TIMING | | | | | | |
| Delay - Start ARINC 32nd Bit to $\overline{D/R}$ LOW: High Speed Low Speed | t _{D/R} | | | 16 | μs | |
| | t _{D/R} | | | 128 | μs | |
| Delay - $\overline{D/R}$ LOW to \overline{EN} LOW Delay - \overline{EN} LOW to $\overline{D/R}$ HIGH | t _{D/REN} | 0 | | | ns | |
| | t _{END/R} | | | 200 | ns | |
| Setup - SEL to \overline{EN} LOW Hold - SEL to \overline{EN} HIGH | t _{SELEN} | 20 | | | ns | |
| | t _{ENSEL} | 50 | | | ns | |
| Delay - \overline{EN} LOW to DATA BUS Valid Delay - \overline{EN} HIGH to DATA BUS Hi-Z | t _{ENDATA} | | | 200 | ns | |
| | t _{DATAEN} | | | 30 | ns | |
| Pulse Width - $\overline{EN1}$ or $\overline{EN2}$ Spacing - \overline{EN} HIGH to next \overline{EN} LOW | t _{EN} | 240 | | | ns | |
| | t _{ENEN} | 50 | | | ns | |
| FIFO TIMING | | | | | | |
| Pulse Width - $\overline{PL1}$ or $\overline{PL2}$ | t _{PL} | 200 | | | ns | |
| Setup - DATA BUS Valid to \overline{PL} HIGH Hold - \overline{PL} HIGH to DATA BUS Hi-Z | t _{DWSET} | 110 | | | ns | |
| | t _{DWHLd} | 20 | | | ns | |
| Spacing - $\overline{PL1}$ or $\overline{PL2}$ | t _{PL12} | 0 | | | ns | |
| Delay - $\overline{PL2}$ HIGH to TX/R LOW | t _{TX/R} | | | 840 | ns | |
| TRANSMISSION TIMING | | | | | | |
| Spacing - $\overline{PL2}$ HIGH to ENTX HIGH | t _{PL2EN} | 0 | | | μs | |
| Delay - 32nd ARINC Bit to TX/R HIGH | t _{DTX/R} | | | 400 | ns | |
| Spacing - TX/R HIGH to ENTX LOW | t _{ENTX/R} | 0 | | | ns | |
| LINE DRIVER OUTPUT TIMING | | | | | | |
| Delay - ENTX HIGH to TXA(OUT) or TXB(OUT): High Speed Delay - ENTX HIGH to TXA(OUT) or TXB(OUT): Low Speed | t _{ENDAT} | | | 27 | μs | |
| | t _{ENDAT} | | | 216 | μs | |
| Line driver transition differential times: (High Speed, Pin 38 - Logic 1) | high to low | t _{fx} | 1.0 | 1.5 | 2.0 | μs |
| | low to high | t _{rx} | 1.0 | 1.5 | 2.0 | μs |
| (Low Speed, Pin 38 = Logic 0) | high to low | t _{fx} | 5.0 | 10 | 15 | μs |
| | low to high | t _{rx} | 5.0 | 10 | 15 | μs |

AC ELECTRICAL CHARACTERISTICS (con't)

V_{cc} = 5V, V₊ = 12V to 15V, V₋ = -12V to -15V, GND = 0V, TA= Oper. Temp. Range and f_{clk} = 1MHz ±0.1% with 60/40 duty cycle

| PARAMETER | SYMBOL | LIMITS | | | UNITS |
|---|---------------------|--------|-----|------|-------|
| | | MIN | TYP | MAX | |
| REPEATER OPERATION TIMING | | | | | |
| Delay - \overline{EN} LOW to \overline{PL} LOW | t _{ENPL} | 0 | | | ns |
| Hold - \overline{PL} HIGH to \overline{EN} HIGH | t _{PLEN} | 0 | | | ns |
| Delay - TX/R LOW to ENTX HIGH | t _{TX/REN} | 0 | | | ns |
| Master Reset Pulse Width | t _{MR} | 400 | | | ns |
| ARINC Data Rate and Bit Timing | | | | ± 1% | |

ADDITIONAL HI-8281 PIN CONFIGURATION

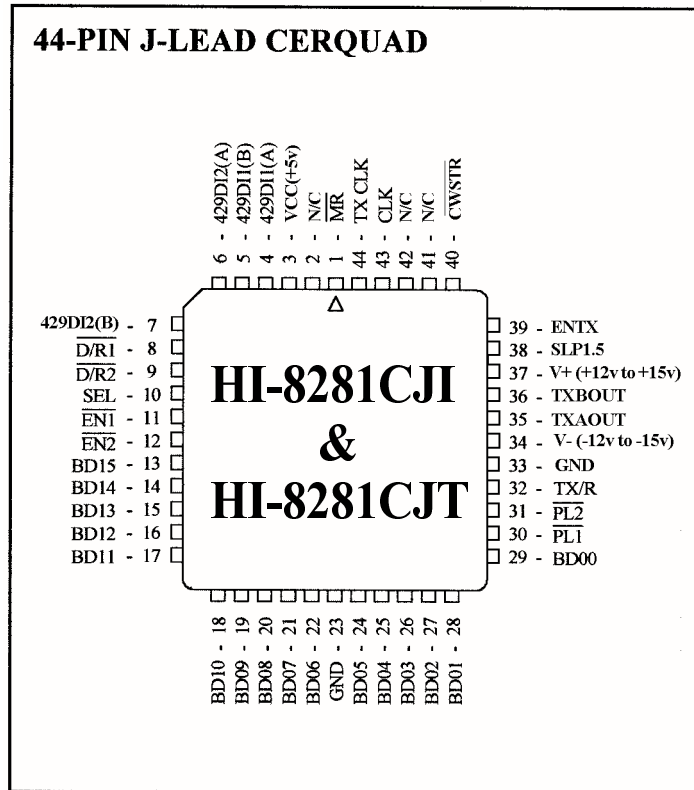

(See page 4-23 for additional pin configuration)

ORDERING INFORMATION

| PART NUMBER | PACKAGE DESCRIPTION | TEMPERATURE RANGE | FLOW | BURN IN | LEAD FINISH |
|-------------|-----------------------|-------------------|------|---------|-------------|
| HI-8281PJI | 44 PIN PLASTIC J LEAD | -40°C TO +85°C | I | NO | SOLDER |
| HI-8281PJT | 44 PIN PLASTIC J LEAD | -55°C TO +125°C | T | NO | SOLDER |
| HI-8281CJI | 44 PIN CERQUAD J LEAD | -40°C TO +85°C | I | NO | SOLDER |
| HI-8281CJT | 44 PIN CERQUAD J LEAD | -55°C TO +125°C | T | NO | SOLDER |

44-PIN PLASTIC J-LEAD PLCC

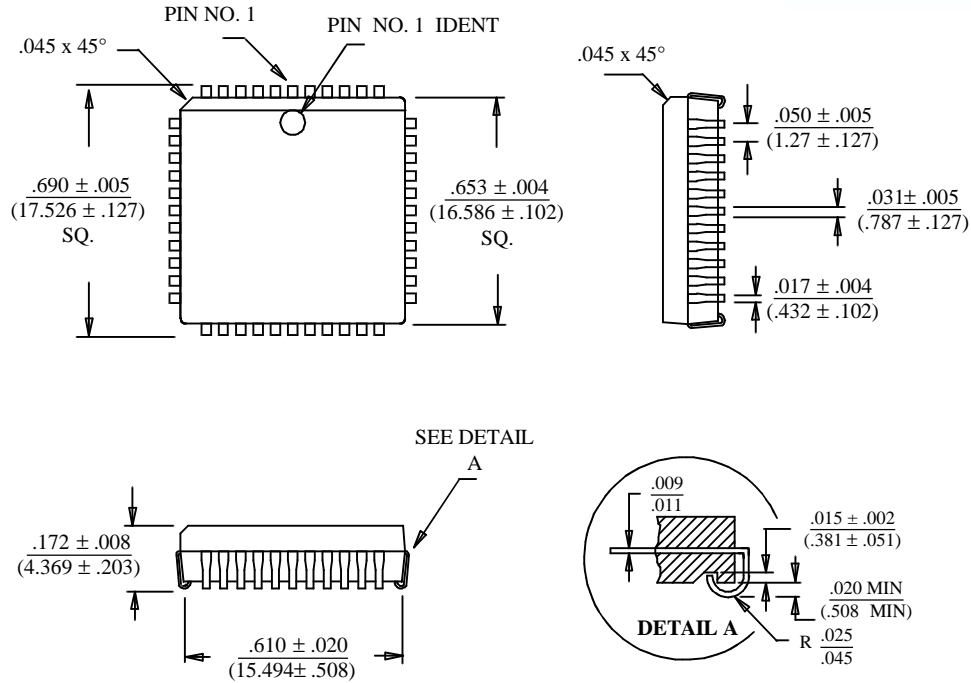

44-PIN CERQUAD J-LEAD

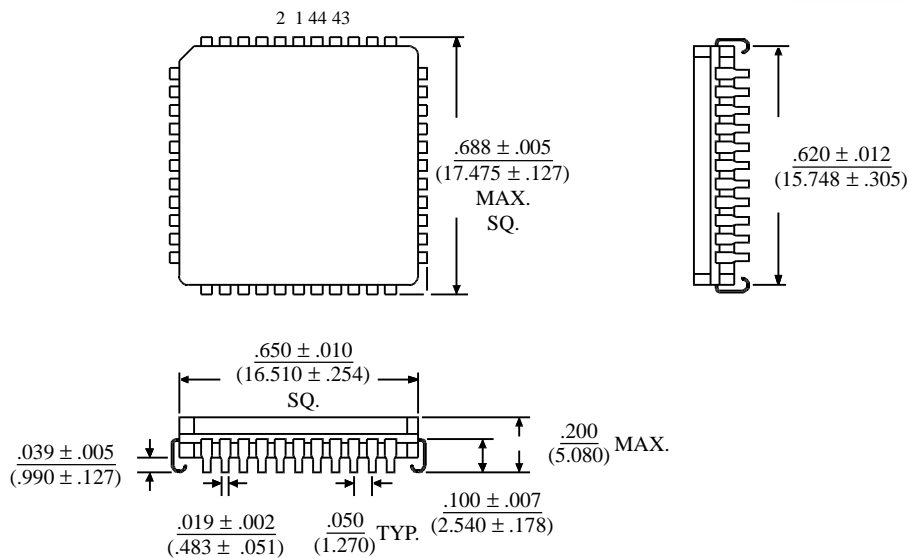

This datasheet has been downloaded from:

www.DatasheetCatalog.com

Datasheets for electronic components.



LittleDiode supplies new, hard to find or obsolete electronic components and semiconductors all over the world.

With over two million different components listed you are sure to find the part you need.

Feel free to visit us today at our online store:

LittleDiode.com

Looking forward to providing you with the best possible service.