

GENERAL DESCRIPTION

The HI-8282A is a silicon gate CMOS device for interfacing the ARINC 429 serial data bus to a 16-bit parallel data bus. Two receivers and an independent transmitter are provided. The receiver input circuitry and logic are designed to meet the ARINC 429 specifications for loading, level detection, timing, and protocol. The transmitter section provides the ARINC 429 communication protocol. Additional interface circuitry such as the Holt HI-8585, HI-8586 or HI-3182 is required to translate the 5 volt logic outputs to ARINC 429 drive levels.

The 16-bit parallel data bus exchanges the 32-bit ARINC data word in two steps when either loading the transmitter or interrogating the receivers. The data bus interfaces with CMOS and TTL.

Timing of all the circuitry begins with the master clock input, CLK. For ARINC 429 applications, the master clock frequency is 1 MHz.

Each independent receiver monitors the data stream with a sampling rate 10 times the data rate. The sampling rate is software selectable at either 1MHz or 125KHz. The results of a parity check are available as the 32nd ARINC bit. The HI-8282A examines the null and data timings and will reject erroneous patterns. For example, with a 125 KHz clock selection, the data frequency must be between 10.4 KHz and 15.6 KHz.

The transmitter has a First In, First Out (FIFO) memory to store 8 ARINC words for transmission. The data rate of the transmitter is software selectable by dividing the master clock, CLK, by either 10 or 80. The master clock is used to set the timing of the ARINC transmission within the required resolution.

APPLICATIONS

- Avionics data communication
- Serial to parallel conversion
- Parallel to serial conversion

FEATURES

- ARINC specification 429 compatible
- 16-Bit parallel data bus
- Direct receiver interface to ARINC bus
- Timing control 10 times the data rate
- Selectable data clocks
- Receiver error rejection per ARINC specification 429
- Automatic transmitter data timing
- Self test mode
- Parity functions
- Low power, single 5 volt supply
- Industrial & full military temperature ranges

PIN CONFIGURATION (Top View)

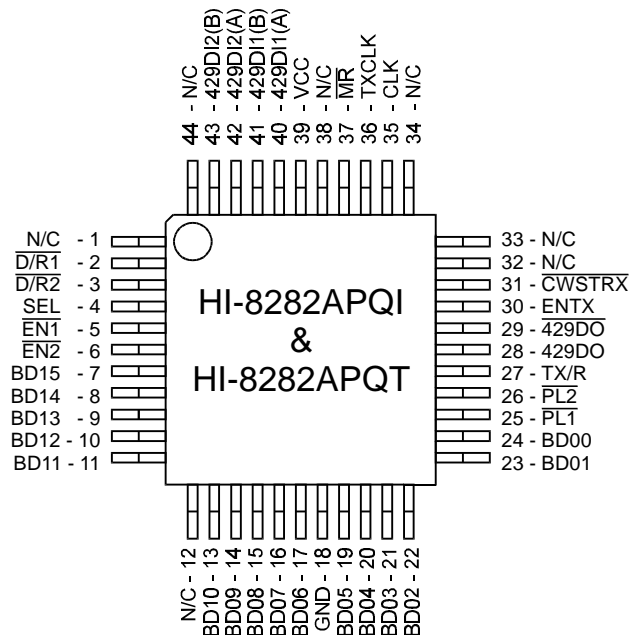

44-Pin Plastic Quad Flat Pack (PQFP)
(See page 10 for additional Package Pin Configurations)

PIN DESCRIPTION

SYMBOL	FUNCTION	DESCRIPTION
VCC	POWER	+5V ±5%
429DI1 (A)	INPUT	ARINC receiver 1 positive input
429DI1 (B)	INPUT	ARINC receiver 1 negative input
429DI2 (A)	INPUT	ARINC receiver 2 positive input
429DI2 (B)	INPUT	ARINC receiver 2 negative input
$\overline{D/R1}$	OUTPUT	Receiver 1 data ready flag
$\overline{D/R2}$	OUTPUT	Receiver 2 data ready flag
SEL	INPUT	Receiver data byte selection (0 = BYTE 1) (1 = BYTE 2)
$\overline{EN1}$	INPUT	Data Bus control, enables receiver 1 data to outputs
$\overline{EN2}$	INPUT	Data Bus control, enables receiver 2 data to outputs if $\overline{EN1}$ is high
BD15	I/O	Data Bus
BD14	I/O	Data Bus
BD13	I/O	Data Bus
BD12	I/O	Data Bus
BD11	I/O	Data Bus
BD10	I/O	Data Bus
BD09	I/O	Data Bus
BD08	I/O	Data Bus
BD07	I/O	Data Bus
BD06	I/O	Data Bus
GND	POWER	0 V
BD05	I/O	Data Bus
BD04	I/O	Data Bus
BD03	I/O	Data Bus
BD02	I/O	Data Bus
BD01	I/O	Data Bus
BD00	I/O	Data Bus
$\overline{PL1}$	INPUT	Latch enable for byte 1 entered from data bus to transmitter FIFO.
$\overline{PL2}$	INPUT	Latch enable for byte 2 entered from data bus to transmitter FIFO. Must follow $\overline{PL1}$.
TX/R	OUTPUT	Transmitter ready flag. Goes low when ARINC word loaded into FIFO. Goes high after transmission and FIFO empty.
429DO	OUTPUT	"ONES" data output from transmitter.
$\overline{429DO}$	OUTPUT	"ZEROES" data output from transmitter.
ENTX	INPUT	Enable Transmission
\overline{CWSTR}	INPUT	Clock for control word register
CLK	INPUT	Master Clock input
TX CLK	OUTPUT	Transmitter Clock equal to Master Clock (CLK), divided by either 10 or 80.
\overline{MR}	INPUT	Master Reset, active low

FUNCTIONAL DESCRIPTION

CONTROL WORD REGISTER

The HI-8282A contains 10 data flip flops whose D inputs are connected to the data bus and clocks connected to CWSTR. Each flip flop provides options to the user as follows:

DATA BUS PIN	FUNCTION	CONTROL	DESCRIPTION
BDO5	SELF TEST	0 = ENABLE	If enabled, an internal connection is made passing 429DO and 429DO to the receiver logic inputs
BDO6	RECEIVER 1 DECODER	1 = ENABLE	If enabled, ARINC bits 9 and 10 must match the next two control word bits
BDO7	-	-	If Receiver 1 Decoder is enabled, the ARINC bit 9 must match this bit
BDO8	-	-	If Receiver 1 Decoder is enabled, the ARINC bit 10 must match this bit
BDO9	RECEIVER 2 DECODER	1 = ENABLE	If enabled, ARINC bits 9 and 10 must match the next two control word bits
BD10	-	-	If Receiver 2 Decoder is enabled, then ARINC bit 9 must match this bit
BD11	-	-	If Receiver 2 Decoder is enabled, then ARINC bit 10 must match this bit
BD12	INVERT XMTR PARITY	1 = ENABLE	Logic 0 enables normal odd parity and Logic 1 enables even parity output in transmitter 32nd bit
BD13	XMTR DATA CLK SELECT	0 = ÷10 1 = ÷80	CLK is divided either by 10 or 80 to obtain XMTR data clock
BD14	RCVR DTA CLK SELECT	0 = ÷10 1 = ÷80	CLK is divided either by 10 or 80 to obtain RCVR data clock

ARINC 429 DATA FORMAT

The following table shows the bit positions in exchanging data with the receiver or the transmitter. ARINC bit 1 is the first bit transmitted or received.

BYTE 1																
DATA BUS	BD 15	BD 14	BD 13	BD 12	BD 11	BD 10	BD 09	BD 08	BD 07	BD 06	BD 05	BD 04	BD 03	BD 02	BD 01	BD 00
ARINC BIT	13	12	11	10	9	31	30	32	1	2	3	4	5	6	7	8

BYTE 2																
DATA BUS	BD 15	BD 14	BD 13	BD 12	BD 11	BD 10	BD 09	BD 08	BD 07	BD 06	BD 05	BD 04	BD 03	BD 02	BD 01	BD 00
ARINC BIT	29	28	27	26	25	24	23	22	21	20	19	18	17	16	15	14

THE RECEIVERS

ARINC BUS INTERFACE

Figure 1 shows the input circuit for each receiver. The ARINC 429 specification requires the following detection levels:

STATE	DIFFERENTIAL VOLTAGE
ONE	+6.5 Volts to +13 Volts
NULL	+2.5 Volts to -2.5 Volts
ZERO	-6.5 Volts to -13 Volts

The HI-8282A guarantees recognition of these levels with a common mode Voltage with respect to GND less than ±5V for the worst case condition (4.75V supply and 13v signal level).

The tolerances in the design guarantee detection of the above levels, so the actual acceptance ranges are slightly larger. If the ARINC signal is out of the actual acceptance ranges, including the nulls, the chip rejects the data.

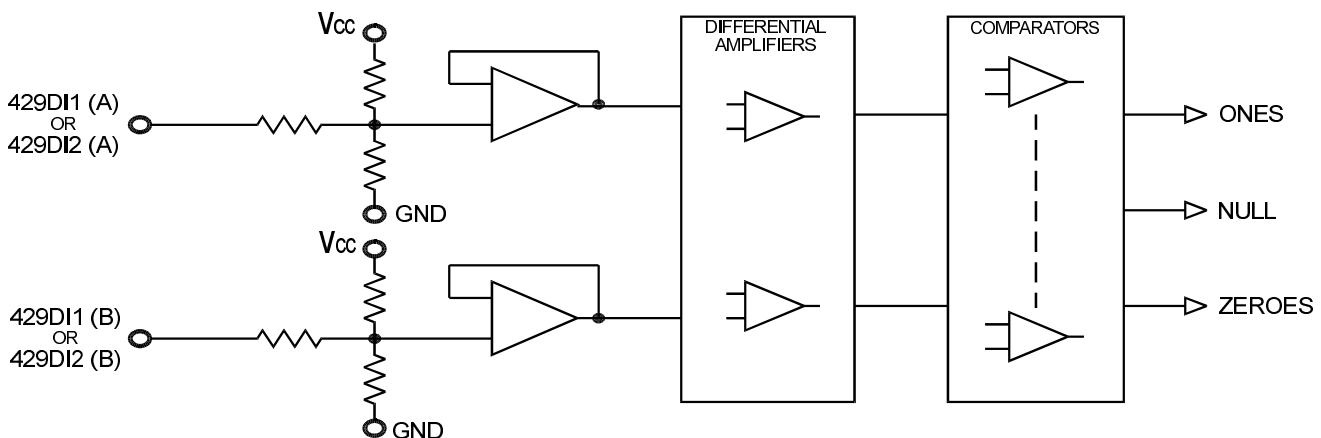

FIGURE 1. ARINC RECEIVER INPUT

FUNCTIONAL DESCRIPTION (con't)

RECEIVER LOGIC OPERATION

Figure 2 shows a block diagram of the logic section of each receiver.

BIT TIMING

The ARINC 429 specification contains the following timing specification for the received data:

	<u>HIGH SPEED</u>	<u>LOW SPEED</u>
BIT RATE	100K BPS \pm 1%	12K -14.5K BPS
PULSE RISE TIME	1.5 \pm 0.5 μ sec	10 \pm 5 μ sec
PULSE FALL TIME	1.5 \pm 0.5 μ sec	10 \pm 5 μ sec
PULSEWIDTH	5 μ sec \pm 5%	34.5 to 41.7 μ sec

Again the HI-8282A accepts signals that meet these specifications and rejects outside the tolerances. The way the logic operation achieves this is described below:

1. Key to the performance of the timing checking logic is an accurate 1MHz clock source. Less than 0.1% error is recommended.
2. The sampling shift registers are 10 bits long and must show three consecutive Ones, Zeros or Nulls to be considered valid data. Additionally, for data bits, the One or Zero in the upper bits of the sampling shift registers must be followed by a Null in the lower bits within the data bit time. For a Null in the word gap, three consecutive Nulls must be found in both the upper and lower bits of the sampling shift register. In this manner the minimum pulse width is guaranteed.

3. Each data bit must follow its predecessor by not less than 8 samples and no more than 12 samples. In this manner the bit rate is checked. With exactly 1MHz input clock frequency, the acceptable data bit rates are as follows:

	<u>HIGH SPEED</u>	<u>LOW SPEED</u>
DATA BIT RATE MIN	83KBPS	10.4K BPS
DATA BIT RATE MAX	125K BPS	15.6K BPS

4. The Word Gap timer samples the Null shift register every 10 input clocks (80 for low speed) after the last data bit of a valid reception. If the Null is present, the Word Gap counter is incremented. A count of 3 will enable the next reception.

RECEIVER PARITY

The receiver parity circuit counts Ones received, including the parity bit, ARINC bit 32. If the result is odd, then "0" will appear in the 32nd bit.

RETRIEVING DATA

Once 32 valid bits are recognized, the receiver logic generates an End of Sequence (EOS). If the receiver decoder is enabled and the 9th and 10th ARINC bits match the control word program bits or if the receiver decoder is disabled, then EOS clocks the data ready flag flip flop to a "1", D/R1 or D/R2 (or both) will go low. The data flag for a receiver will remain low until after both ARINC bytes from that receiver are retrieved. This is accomplished by activating \overline{EN} with SEL, the byte selector, low to retrieve the first byte and activating \overline{EN} with SEL high to retrieve the second byte. $\overline{EN1}$ retrieves data from receiver 1 and $\overline{EN2}$ retrieves data from receiver 2.

If another ARINC word is received, and a new EOS occurs before the two bytes are retrieved, the data is overwritten by the new word.

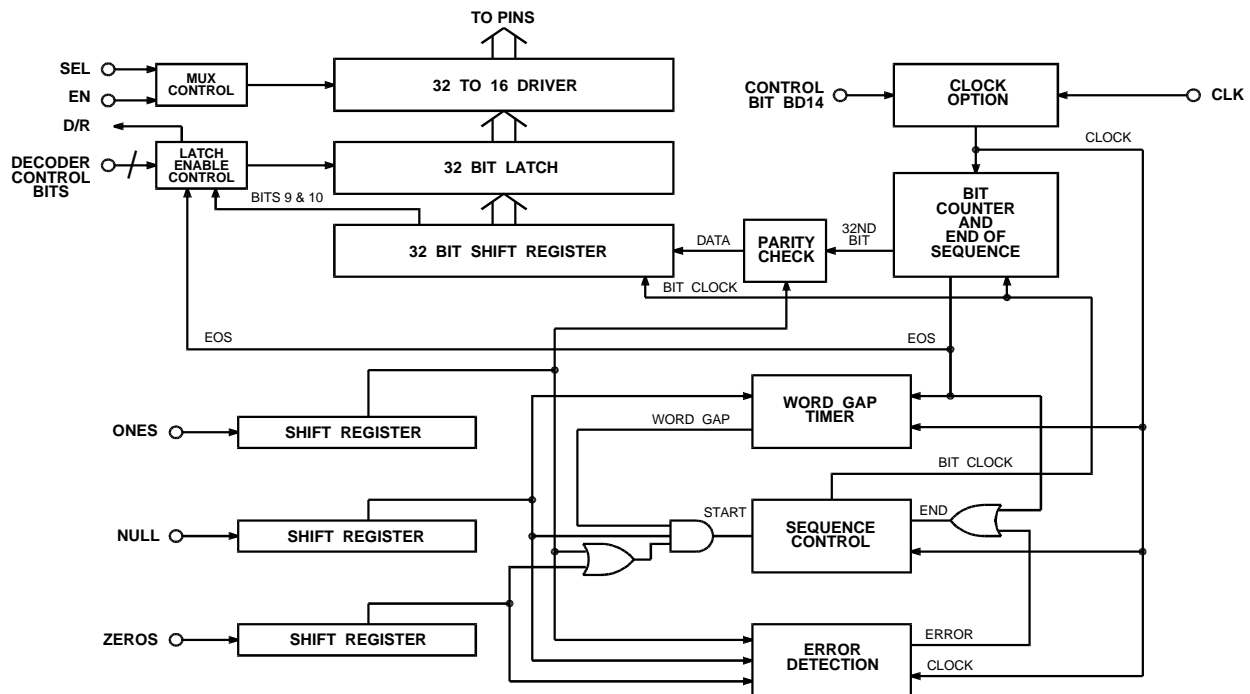

FIGURE 2. RECEIVER BLOCK DIAGRAM

FUNCTIONAL DESCRIPTION (con't)

TRANSMITTER

A block diagram of the transmitter section is shown in Figure 3.

FIFO OPERATION

The FIFO is loaded sequentially by first pulsing $\overline{PL1}$ to load byte 1 and then $\overline{PL2}$ to load byte 2. The control logic automatically loads the 31 bit word in the next available position of the FIFO. If TX/R, the transmitter ready flag is high (FIFO empty), then 8 words, each 31 bits long, may be loaded. If TX/R is low, then only the available positions may be loaded. If all 8 positions are full, the FIFO ignores further attempts to load data.

DATA TRANSMISSION

When ENTX goes high, enabling transmission, the FIFO positions are incremented with the top register loading into the data transmission shift register. Within 2.5 data clocks the first data bit appears at either 429DO or 429DO. The 31 bits in the data transmission shift register are presented sequentially to the outputs in the ARINC 429 format with the following timing:

	<u>HIGH SPEED</u>	<u>LOW SPEED</u>
ARINC DATA BIT TIME	10 Clocks	80 Clocks
DATA BIT TIME	5 Clocks	40 Clocks
NULL BIT TIME	5 Clocks	40 Clocks
WORD GAP TIME	40 Clocks	320 Clocks

The word counter detects when all loaded positions are transmitted and sets the transmitter ready flag, TX/R, high.

TRANSMITTER PARITY

The parity generator counts the ONES in the 31-bit word. If the BD12 control word bit is set low, the 32nd bit transmitted will make parity odd. If the control bit is high the parity is even.

SELF TEST

If the BD05 control word bit is set low, 429DO or $\overline{429DO}$ become inputs to the receiver bypassing the interface circuitry.

SYSTEM OPERATION

The two receivers are independent of the transmitter. Therefore, control of data exchanges are strictly at the option of the user. The only restrictions are:

1. The received data may be overwritten if not retrieved within one ARINC word cycle.
2. The FIFO can store 8 words maximum and ignores attempts to load addition data if full.
3. Byte 1 of the transmitter data must be loaded first.
4. Either byte of the received data may be retrieved first. Both bytes must be retrieved to clear the data ready flag.
5. After ENTX, transmission enable, goes high it cannot go low until TX/R, transmitter readyflag, goes high. Otherwise, one ARINC word is lost during transmission.

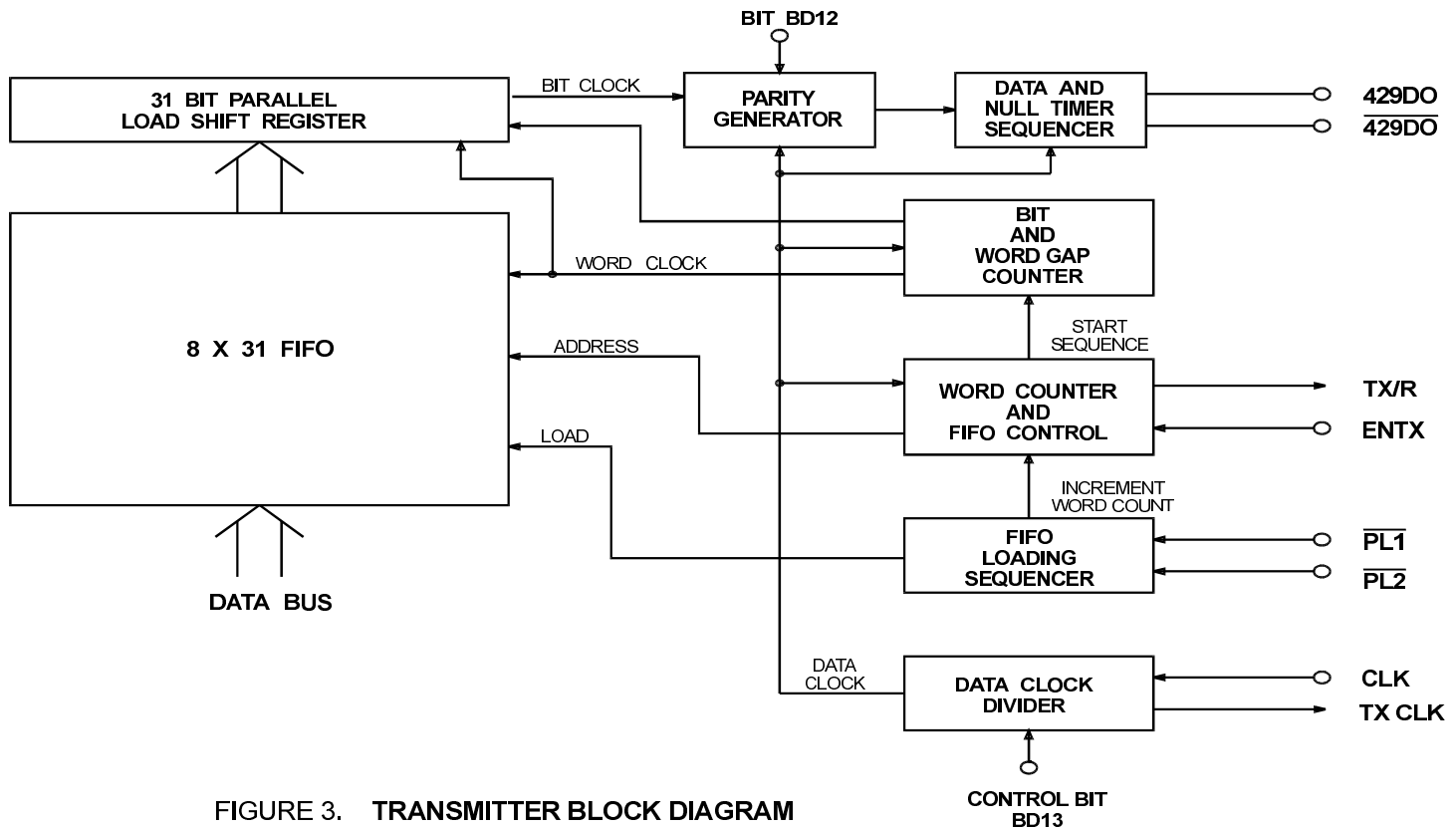

FIGURE 3. TRANSMITTER BLOCK DIAGRAM

FUNCTIONAL DESCRIPTION (con't)

will also be placed into the transmitter FIFO. SEL is then taken high and \overline{EN} is strobed again to place the upper byte of the data word on the data bus. By strobing $\overline{PL2}$ at the same time as \overline{EN} , the second byte will also be placed into the FIFO. The data word is now ready to be transmitted according to the parity programmed into the control word register.

REPEATER OPERATION

The repeater mode of operation allows a data word that has been received by the HI-8282A to be placed directly into its FIFO for transmission. After a 32-bit word has been shifted into the receiver shift register, the $\overline{D/R}$ flag will go low. A logic "0" is placed on the SEL line and \overline{EN} is strobed. This is the same procedure as for normal receiver operation and it places the lower byte (16) of the data word on the data bus. By strobing $\overline{PL1}$ at the same time as \overline{EN} , the byte

In normal operation, either byte of a received data word may be read from the receiver latches first by use of SEL input. During repeater operation however, the lower byte of the data word must be read first. This is necessary because, as the data is being read, it is also being loaded into the FIFO and the transmitter FIFO is always loaded with the lower byte of the data word first.

TIMING DIAGRAMS

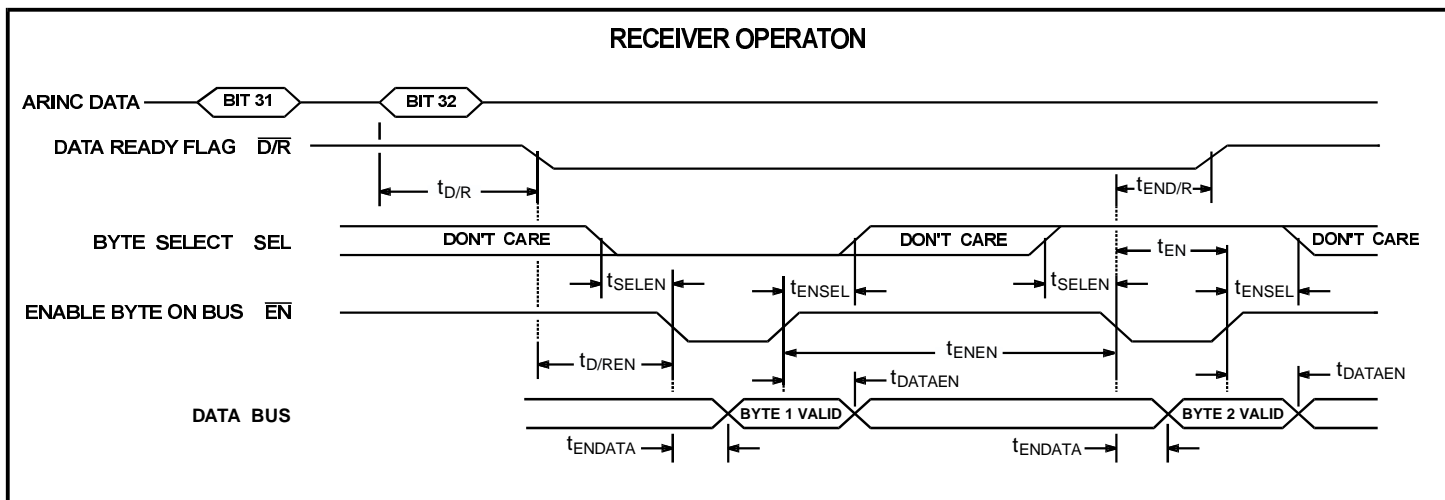
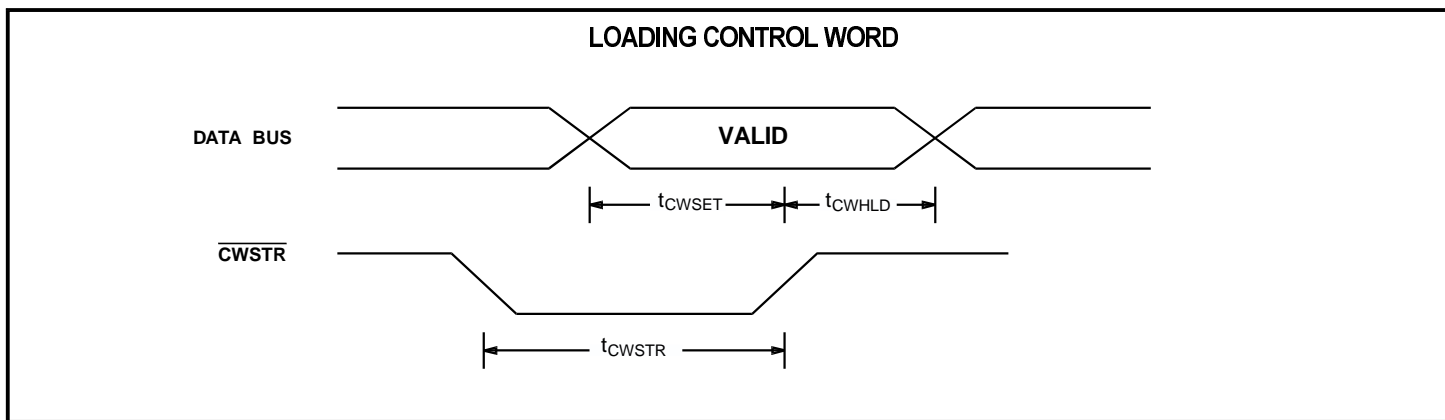
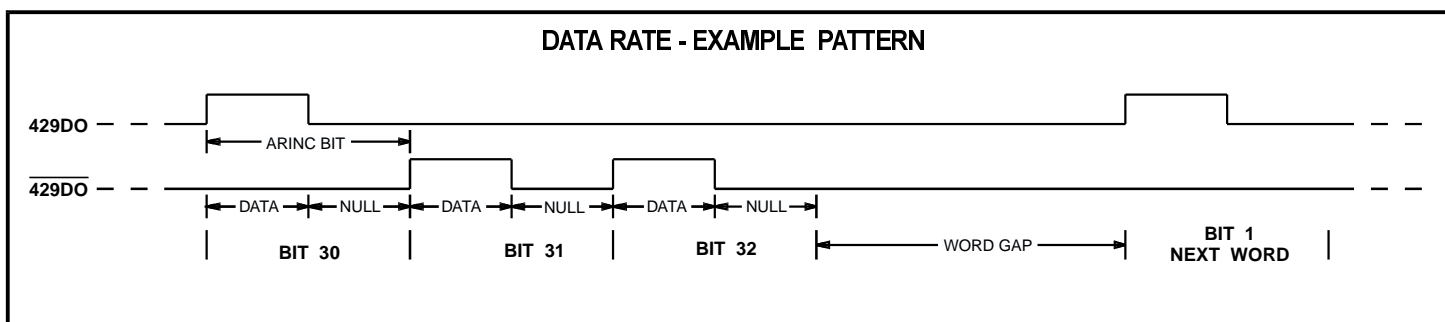

TIMING DIAGRAMS (con't)

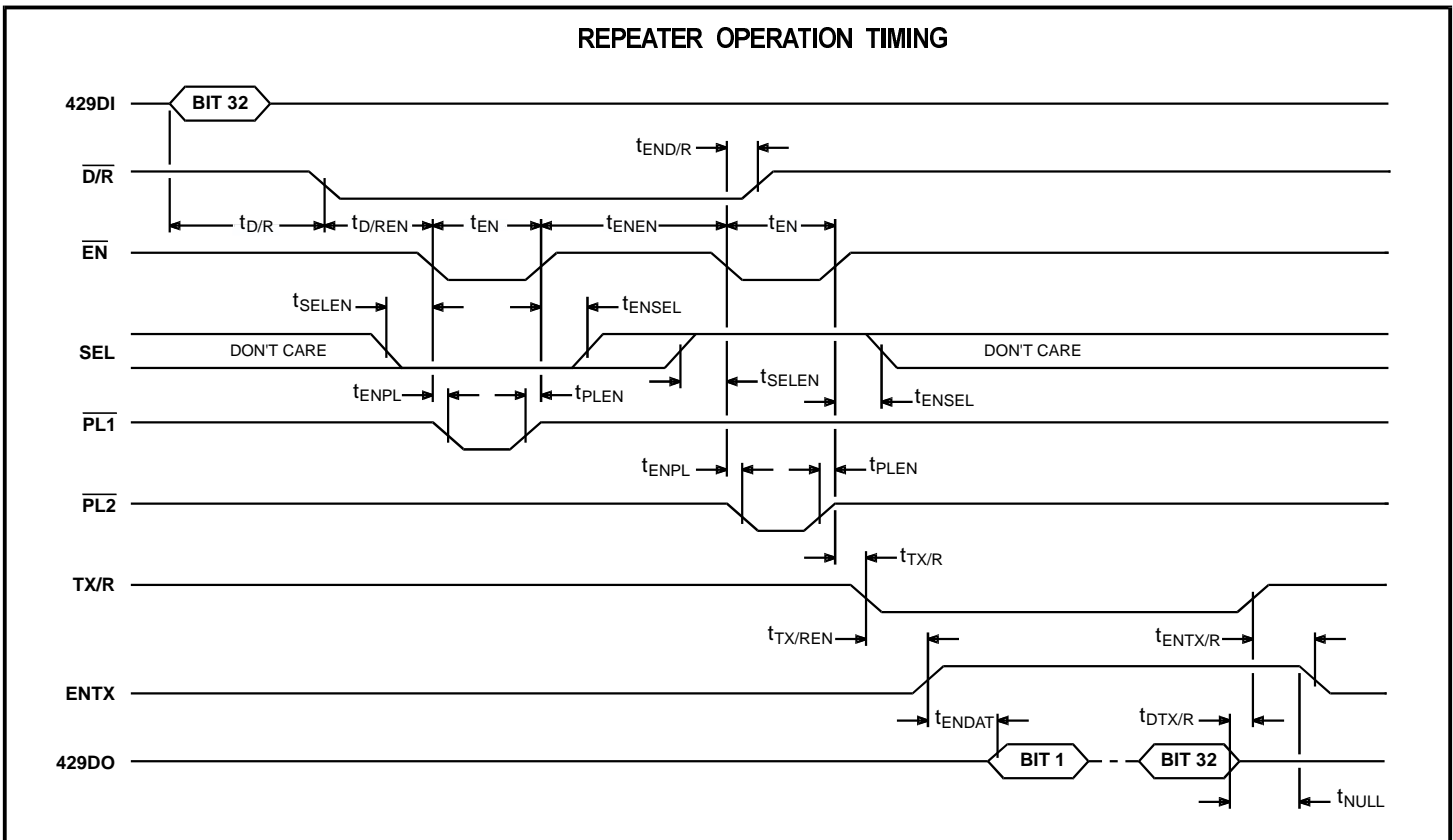
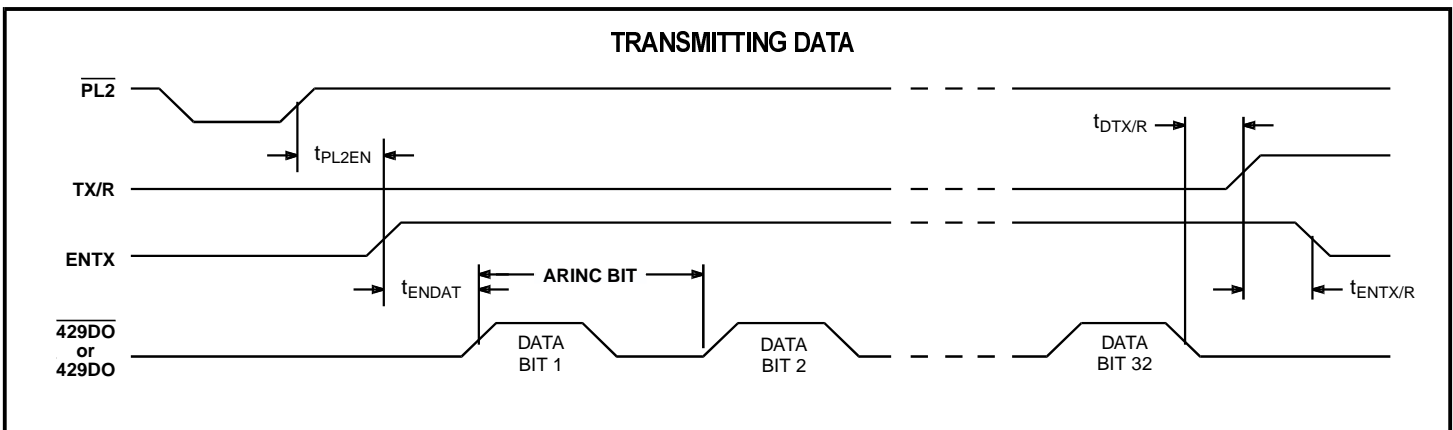
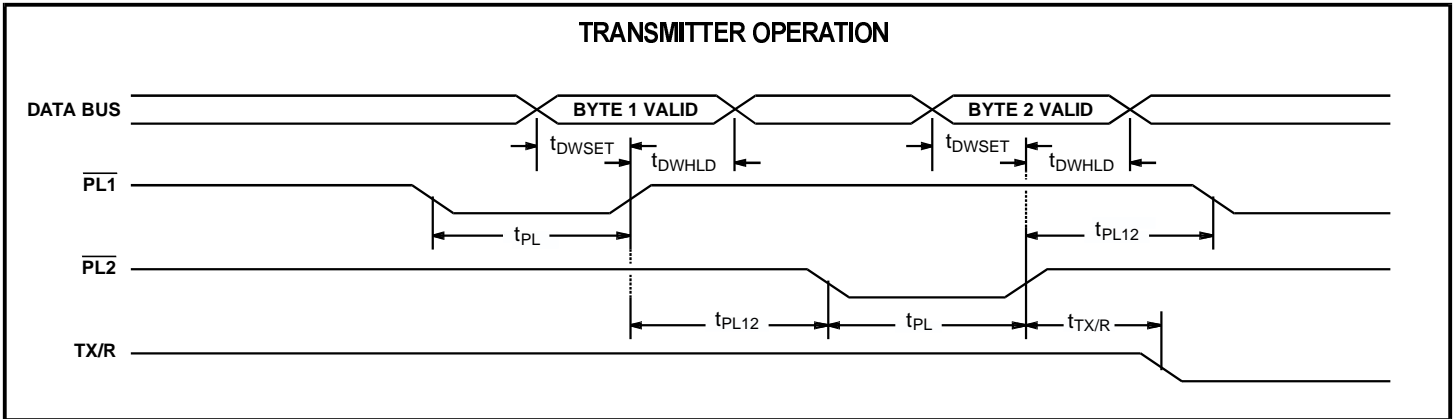

ABSOLUTE MAXIMUM RATINGS

Supply Voltage V_{CC}	-0.3V to +7V	Power Dissipation	500mW
Voltage at ARINC Inputs	-29V to +29V	Operating Temperature Range: (Industrial)	-40°C to +85°C
Voltage at any other pin	-0.3V to $V_{CC} + 0.3V$		(Military)
DC Current Drain per input pin	10mA	Storage Temperature Range:	-65°C to +150°C

NOTE: Stresses above those listed under "Absolute Maximum Ratings" may cause permanent damage to the device. These are stress ratings only. Functional operation of the device at these or any other conditions above those indicated in the operational sections of the specifications is not implied. Exposure to absolute maximum rating conditions for extended periods may affect device reliability.

DC ELECTRICAL CHARACTERISTICS

$V_{CC} = 5V \pm 5\%$, $GND = 0V$, $T_A =$ Operating Temperature Range (unless otherwise specified).

PARAMETER	SYMBOL	CONDITIONS	LIMITS			UNIT
			MIN	TYP	MAX	
ARINC INPUTS - 429DI1 (A), 429DI1 (B), 429DI2 (A) & 429DI2 (B)						
Differential Input Voltage:	ONE	V_{IH}	6.5	10.0	13.0	V
	ZERO	V_{IL}	-13.0	-10.0	-6.5	V
	NULL	V_{NUL}	-2.5	0	2.5	V
Input Resistance:	Differential To GND To V_{CC}	R_I	12			K Ω
		R_G	12	27		K Ω
		R_H	12	27		K Ω
Input Current:	Input Sink Input Source	I_{IH}			200	μA
		I_{IL}	-450			μA
Input Capacitance: (Guaranteed but not tested)	Differential To GND To V_{CC}	C_I			20	pF
		C_G			20	pF
		C_H			20	pF
			Pins 2 to 3, 4 to 5			
BI-DIRECTIONAL INPUTS - BD00 through BD15						
Input Voltage:	Input Voltage HI Input Voltage LO	V_{IH}	2.1			V
		V_{IL}			0.7	V
Input Current:	Input Sink Input Source	I_{IH} I_{IL}	-1.5		1.5	μA μA
ALL OTHER INPUTS - SEL, EN1, EN2, PL1, PL2, ENTX, CWSTR, CLK & MR						
Input Voltage:	Input Voltage HI Input Voltage LO	V_{IH}	3.5			V
		V_{IL}			0.7	V
Input Current:	Input Sink Input Source	I_{IH} I_{IL}	-20		10	μA μA
OUTPUTS - $\overline{D/R1}$, $\overline{D/R2}$, BD00 through BD15, TX/R, 429DO, $\overline{429D0}$ & TX CLK						
Output Voltage:	Logic "1" Output Voltage Logic "0" Output Voltage	V_{OH}	2.7			V
		V_{OL}			0.4	V
Output Current: (Bi-directional Pins)	Output Sink Output Source	I_{OL}	3.0			mA
		I_{OH}	1.1			mA
Output Current: (All Other Outputs)	Output Sink Output Source	I_{OL}	2.6			mA
		I_{OH}	1.1			mA
Output Capacitance:		C_O			15	pF
SUPPLY INPUT - V_{CC}						
Standby Supply Current:		I_{CC1}			20	mA
Operating Supply Current:		I_{CC2}			20	mA

AC ELECTRICAL CHARACTERISTICS

V_{cc} = 5V, GND = 0V, TA = Operating Temperature Range and f_{clk} = 1MHz ±0.1% with 60/40 duty cycle

PARAMETER	SYMBOL	LIMITS			UNITS
		MIN	TYP	MAX	
CONTROL WORD TIMING					
Pulse Width - \overline{CWSTR}	tcwstr	130			ns
Setup - DATA BUS Valid to \overline{CWSTR} HIGH	tcwset	130			ns
Hold - \overline{CWSTR} HIGH to DATA BUS Hi-Z	tcwhld	0			ns
RECEIVER TIMING					
Delay - Start ARINC 32nd Bit to $\overline{D/R}$ LOW: High Speed Low Speed	t _{D/R}			16	μs
	t _{D/R}			128	μs
Delay - $\overline{D/R}$ LOW to \overline{EN} LOW Delay - \overline{EN} LOW to $\overline{D/R}$ HIGH	t _{D/REN} t _{END/R}	0		200	ns ns
Setup - SEL to \overline{EN} LOW Hold - SEL to \overline{EN} HIGH	t _{SELEN} t _{ENSEL}	20 20			ns ns
Delay - \overline{EN} LOW to DATA BUS Valid Delay - \overline{EN} HIGH to DATA BUS Hi-Z	t _{ENDATA} t _{DATAEN}			200 30	ns ns
Pulse Width - $\overline{EN1}$ or $\overline{EN2}$ Spacing - \overline{EN} HIGH to next \overline{EN} LOW	t _{EN} t _{ENEN}	200 50			ns ns
FIFO TIMING					
Pulse Width - $\overline{PL1}$ or $\overline{PL2}$	t _{PL}	200			ns
Setup - DATA BUS Valid to \overline{PL} HIGH Hold - \overline{PL} HIGH to DATA BUS Hi-Z	t _{DWSET} t _{DWHLD}	110 0			ns ns
Spacing - $\overline{PL1}$ or $\overline{PL2}$	t _{PL12}	0			ns
Delay - $\overline{PL2}$ HIGH to TX/R LOW	t _{TX/R}			840	ns
TRANSMISSION TIMING					
Spacing - $\overline{PL2}$ HIGH to ENTX HIGH	t _{PL2EN}	0			μs
Delay - ENTX HIGH to 429D0 or $\overline{429D0}$: High Speed Delay - ENTX HIGH to 429D0 or $\overline{429D0}$: Low Speed	t _{ENDAT} t _{ENDAT}			25 200	μs μs
Delay - 32nd ARINC Bit to TX/R HIGH	t _{DTX/R}			400	ns
Spacing - TX/R HIGH to ENTX LOW	t _{ENTX/R}	0			ns
REPEATER OPERATION TIMING					
Delay - \overline{EN} LOW to \overline{PL} LOW	t _{ENPL}	0			ns
Hold - \overline{PL} HIGH to \overline{EN} HIGH	t _{PLEN}	0			ns
Delay - TX/R LOW to ENTX HIGH	t _{TX/REN}	0			ns
Master Reset Pulse Width	t _{MR}	200			ns
ARINC Data Rate and Bit Timing				± 1%	

ADDITIONAL HI-8282A PIN CONFIGURATIONS

(See page 1 for the 44-pin Plastic Quad Flat Pack)

44-PIN PLASTIC PLCC

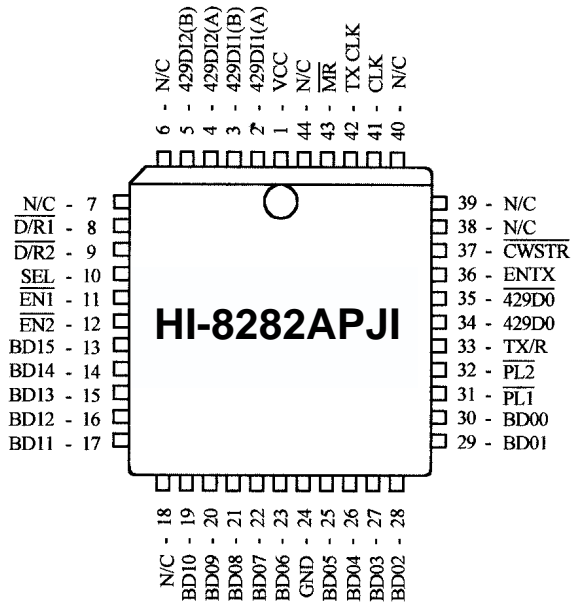

44-PIN J-LEAD CERQUAD

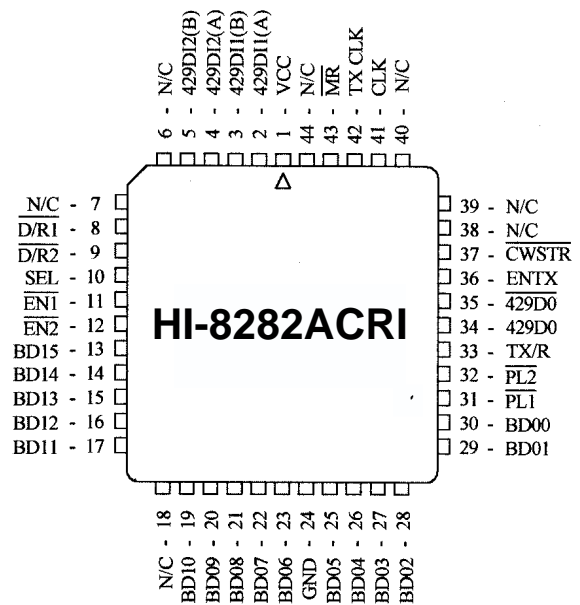

44-PIN CERAMIC LCC

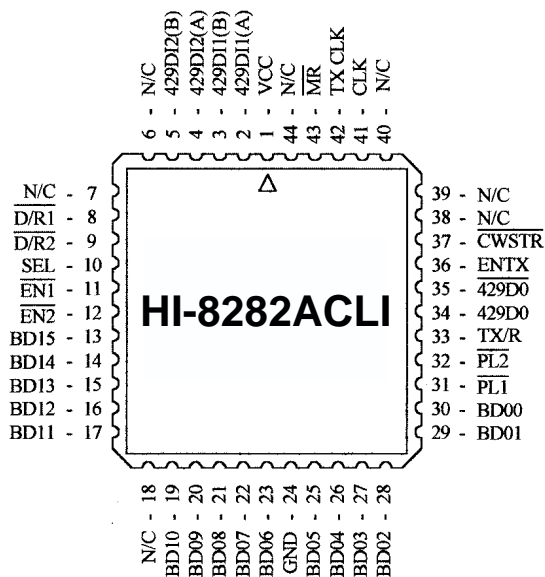

40-PIN CERAMIC SIDE BRAZED DIP

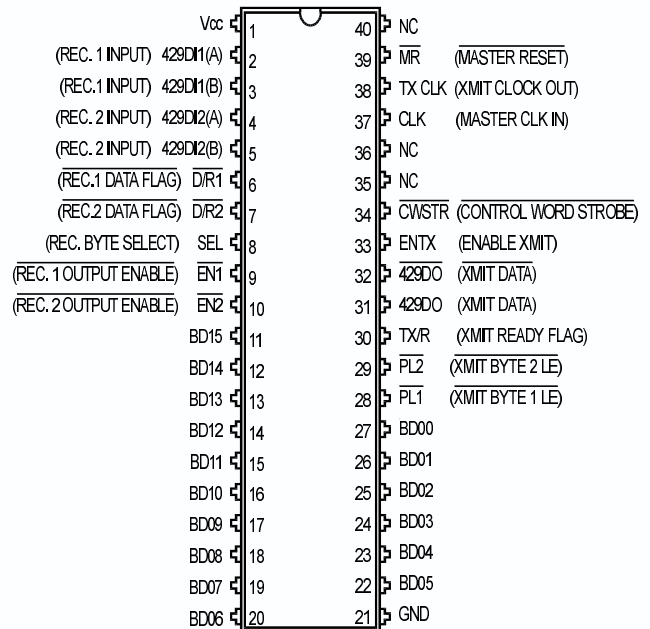

HI-8282ACDI

ORDERING INFORMATION

PART NUMBER	PACKAGE DESCRIPTION	TEMPERATURE RANGE	FLOW	BURN IN	LEAD FINISH
HI-8282ACDI	40 PIN CERAMIC SIDE BRAZED DIP	-40°C TO +85°C	I	NO	GOLD
HI-8282ACDT	40 PIN CERAMIC SIDE BRAZED DIP	-55°C TO +125°C	T	NO	GOLD
HI-8282ACDM	40 PIN CERAMIC SIDE BRAZED DIP	-55°C TO +125°C	M	YES	SOLDER
HI-8282APJI	44 PIN PLASTIC J LEAD	-40°C TO +85°C	I	NO	SOLDER
HI-8282APJT	44 PIN PLASTIC J LEAD	-55°C TO +125°C	T	NO	SOLDER
HI-8282APQI	44 PIN PLASTIC QUAD FLAT PACK	-40°C TO +85°C	I	NO	SOLDER
HI-8282APQT	44 PIN PLASTIC QUAD FLAT PACK	-55°C TO +125°C	T	NO	SOLDER
HI-8282ACLI	44 PIN CERAMIC LEADLESS CHIP CARRIER	-40°C TO +85°C	I	NO	GOLD
HI-8282ACLT	44 PIN CERAMIC LEADLESS CHIP CARRIER	-55°C TO +125°C	T	NO	GOLD
HI-8282ACLM	44 PIN CERAMIC LEADLESS CHIP CARRIER	-55°C TO +125°C	M	YES	SOLDER
HI-8282ACRI	44 PIN CERQUAD	-40°C TO +85°C	I	NO	SOLDER
HI-8282ACRT	44 PIN CERQUAD	-55°C TO +125°C	T	NO	SOLDER

40-PIN CERAMIC SIDE-BRAZED DIP

Package Type: 40C

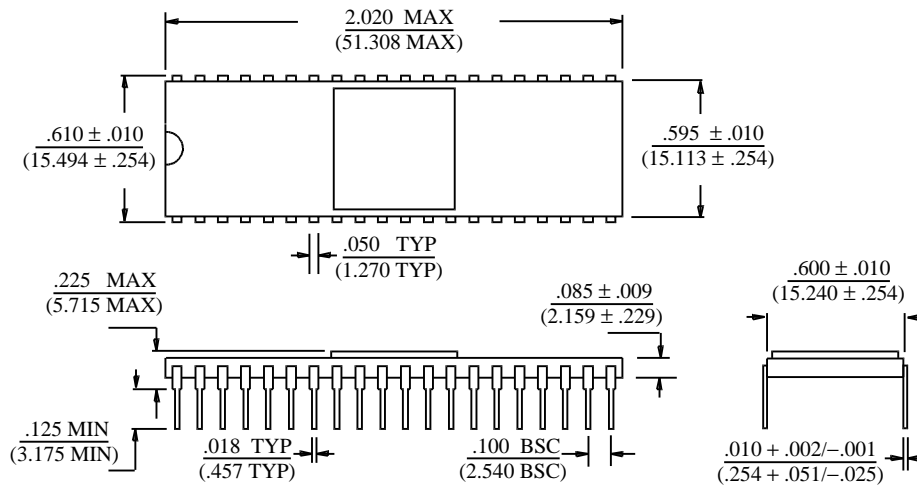

44-PIN J-LEAD CERQUAD

Package Type: 44U

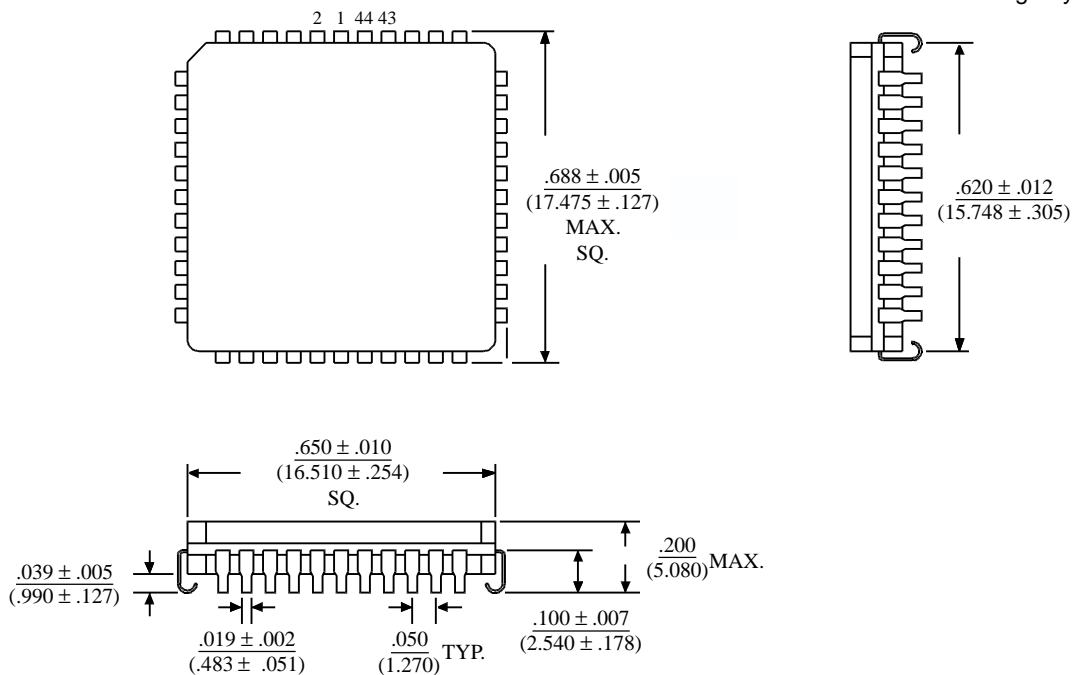

44-PIN PLASTIC PLCC

Package Type: 44J

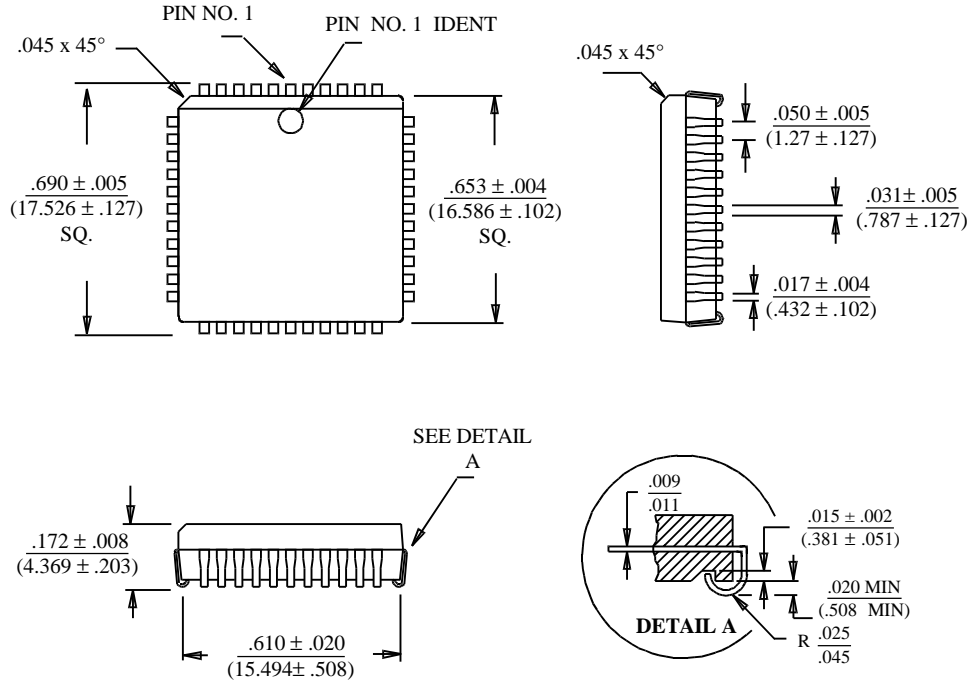

44-PIN PLASTIC QUAD FLAT PACK (PQFP)

Package Type: 44PQS

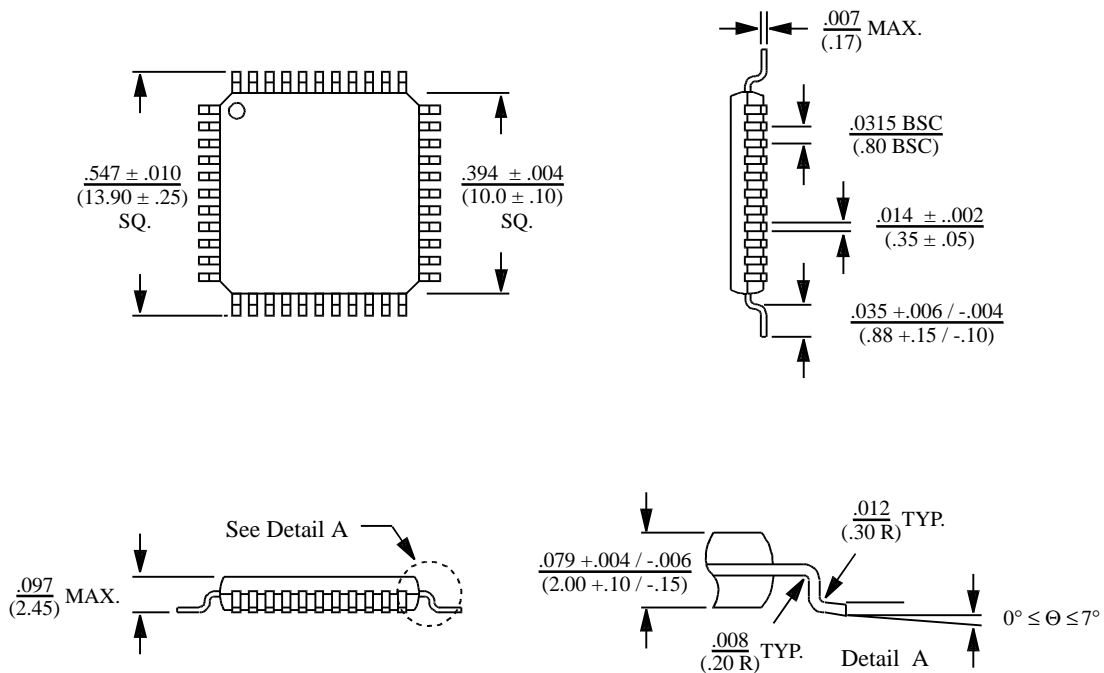

44-PIN CERAMIC LEADLESS CHIP CARRIER

Package Type: 44S

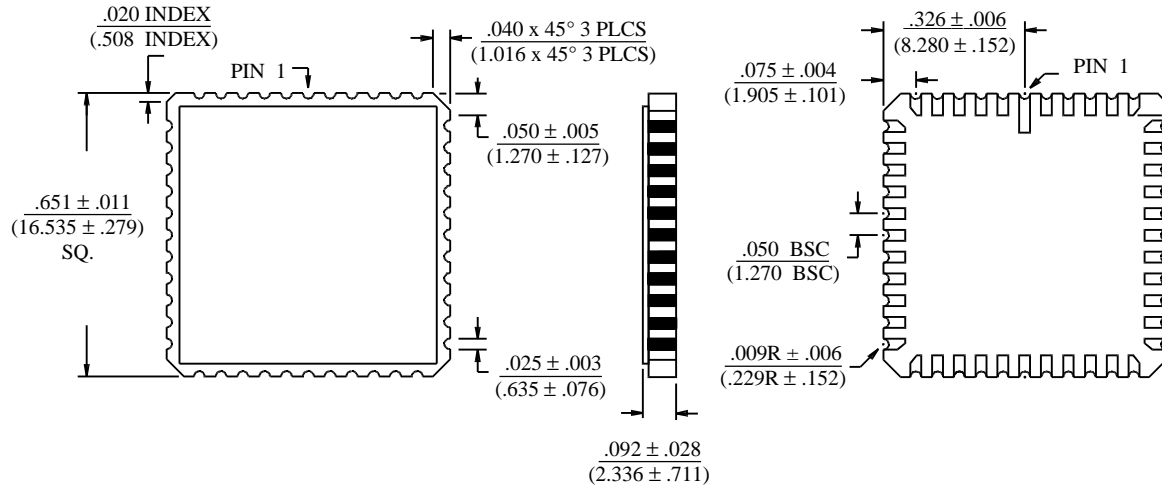

This datasheet has been downloaded from:

www.DatasheetCatalog.com

Datasheets for electronic components.



LittleDiode supplies new, hard to find or obsolete electronic components and semiconductors all over the world.

With over two million different components listed you are sure to find the part you need.

Feel free to visit us today at our online store:

LittleDiode.com

Looking forward to providing you with the best possible service.