

## High Speed +5V Powered RS-232 Transmitters/Receivers

The HIN202A-HIN241A family of high-speed RS-232 transmitters/receivers interface circuits meet all EIA high-speed RS-232E and V.28 specifications, and are particularly suited for those applications where  $\pm 12V$  is not available. They require a single +5V power supply and feature onboard charge pump voltage converters which generate +10V and -10V supplies from the 5V supply. The HIN205A and HIN235A require no external capacitors and are ideally suited for applications where circuit board space is critical. The family of devices offers a wide variety of high-speed RS-232 transmitter/receiver combinations to accommodate various applications (see Selection Table).

The HIN205A, HIN206A, HIN211A, HIN213A, HIN235A, HIN236A, and HIN241A feature a low power shutdown mode to conserve energy in battery powered applications. In addition, the HIN213A provides two active receivers in shutdown mode allowing for easy "wake-up" capability.

The drivers feature true TTL/CMOS input compatibility, slew rate-limited output, and  $300\Omega$  power-off source impedance. The receivers can handle up to  $\pm 30V$  input, and have a  $3k\Omega$  to  $7k\Omega$  input impedance. The receivers also feature hysteresis to greatly improve noise rejection.

## Applications

- Any System Requiring High-Speed RS-232 Communication Ports
  - Computer - Portable, Mainframe, Laptop
  - Peripheral - Printers and Terminals
  - Instrumentation, UPS
  - Modems

## Selection Table

PART NUMBER	POWER SUPPLY VOLTAGE	NUMBER OF RS-232 DRIVERS	NUMBER OF RS-232 RECEIVERS	NUMBER OF 0.1 $\mu$ F EXTERNAL CAPACITORS	LOW POWER SHUTDOWN/TTL THREE-STATE	NUMBER OF RECEIVERS ACTIVE IN SHUTDOWN
HIN202A	+5V	2	2	4 Capacitors	No/No	0
HIN205A	+5V	5	5	None	Yes/Yes	0
HIN206A	+5V	4	3	4 Capacitors	Yes/Yes	0
HIN207A	+5V	5	3	4 Capacitors	No/No	0
HIN208A	+5V	4	4	4 Capacitors	No/N	0
HIN211A	+5V	4	5	4 Capacitors	Yes/Yes	0
HIN213A	+5V	4	5	4 Capacitors	Yes/Yes	2
HIN232A	+5V	2	2	4 Capacitors	No/No	0
HIN235A	+5V	5	5	None	Yes/Yes	0
HIN236A	+5V	4	3	4 Capacitors	Yes/Yes	0
HIN237A	+5V	5	3	4 Capacitors	No/No	0
HIN238A	+5V	4	4	4 Capacitors	No/No	0
HIN241A	+5V	4	5	4 Capacitors	Yes/Yes	0

## Features

- Meets All RS-232E and V.28 Specifications
- Requires Only 0.1 $\mu$ F or Greater External Capacitors (HIN205A, HIN235A and Require No External Capacitors)
- High Data Rate. . . . . 230kbit/s
- Two Receivers Active in Shutdown Mode (HIN213A)
- Requires Only Single +5V Power Supply
- Onboard Voltage Doubler/Inverter
- Low Power Consumption (Typ) . . . . . 5mA
- Low Power Shutdown Function (Typ) . . . . . 1 $\mu$ A
- Three-State TTL/CMOS Receiver Outputs
- Multiple Drivers
  - $\pm 10V$  Output Swing for +5V Input
  - $300\Omega$  Power-Off Source Impedance
  - Output Current Limiting
  - TTL/CMOS Compatible
- Multiple Receivers
  - $\pm 30V$  Input Voltage Range
  - $3k\Omega$  to  $7k\Omega$  Input Impedance
  - 0.5V Hysteresis to Improve Noise Rejection

**Ordering Information**

PART NO.	TEMP. RANGE (°C)	PACKAGE	PKG. NO.
HIN202ACA-T	0 to 70	Tape and Reel	
HIN202ACB	0 to 70	16 Ld SOIC	M16.3
HIN202ACB-T	0 to 70	Tape and Reel	
HIN202ACBN	0 to 70	16 Ld SOIC	M16.15
HIN202ACBN-T	0 to 70	Tape and Reel	
HIN202ACP	0 to 70	16 Ld PDIP	E16.3
HIN205ACP	0 to 70	24 Ld PDIP	E24.6
HIN206ACA	0 to 70	24 Ld SSOP	M24.209
HIN206ACA-T	0 to 70	Tape and Reel	
HIN206ACB	0 to 70	24 Ld SOIC (W)	M24.3
HIN206ACB-T	0 to 70	Tape and Reel	
HIN206ACP	0 to 70	24 Ld PDIP	E24.3
HIN207ACA	0 to 70	24 Ld SSOP	M24.209
HIN207ACA-T	0 to 70	Tape and Reel	
HIN207ACB	0 to 70	24 Ld SOIC	M24.3
HIN207ACB-T	0 to 70	Tape and Reel	
HIN207ACP	0 to 70	24 Ld PDIP	E24.3
HIN208ACA	0 to 70	24 Ld SSOP	M24.209
HIN208ACA-T	0 to 70	Tape and Reel	
HIN208ACB	0 to 70	24 Ld SOIC	M24.3
HIN208ACB-T	0 to 70	Tape and Reel	
HIN208ACP	0 to 70	24 Ld PDIP	E24.3
HIN211ACA	0 to 70	28 Ld SSOP	M28.209
HIN211ACA-T	0 to 70	Tape and Reel	
HIN211ACB	0 to 70	28 Ld SOIC	M28.3

PART NO.	TEMP. RANGE (°C)	PACKAGE	PKG. NO.
HIN211ACB-T	0 to 70	Tape and Reel	
HIN213ACA	0 to 70	24 Ld SSOP	M28.209
HIN213ACA-T	0 to 70	Tape and Reel	
HIN213ACB	0 to 70	28 Ld SOIC	M28.3
HIN213ACB-T	0 to 70	Tape and Reel	
HIN232ACA	0 to 70	16 Ld SSOP	M16.209
HIN232ACA-T	0 to 70	Tape and Reel	
HIN232ACB	0 to 70	16 Ld SOIC	M16.3
HIN232ACB-T	0 to 70	Tape and Reel	
HIN232ACBN	0 to 70	16 Ld SOIC (N)	M16.15
HIN232ACBN-T	0 to 70	Tape and Reel	
HIN232ACP	0 to 70	16 Ld PDIP	E16.3
HIN235ACP	0 to 70	24 Ld PDIP	E24.6
HIN236ACA	0 to 70	24 Ld SSOP	M24.209
HIN236ACB	0 to 70	24 Ld SOIC (W)	M24.3
HIN236ACB-T	0 to 70	Tape and Reel	
HIN236ACP	0 to 70	24 Ld PDIP	E24.3
HIN237ACA	0 to 70	24 Ld SSOP	M24.209
HIN237ACB	0 to 70	24 Ld SOIC	M24.3
HIN237ACP	0 to 70	24 Ld PDIP	E24.3
HIN238ACA	0 to 70	24 Ld SSOP	M24.209
HIN238ACB	0 to 70	24 Ld SOIC	M24.3
HIN238ACP	0 to 70	24 Ld PDIP	E24.3
HIN241ACA	0 to 70	28 Ld SSOP	M28.209
HIN241ACB	0 to 70	28 Ld SOIC	M28.3

Pinouts

HIN202A (PDIP, SOIC)  
TOP VIEW

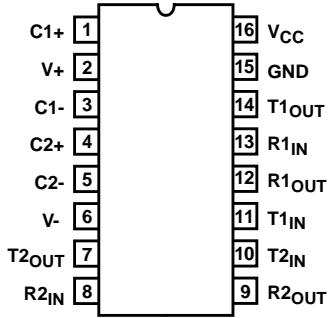

HIN205A (PDIP)  
TOP VIEW

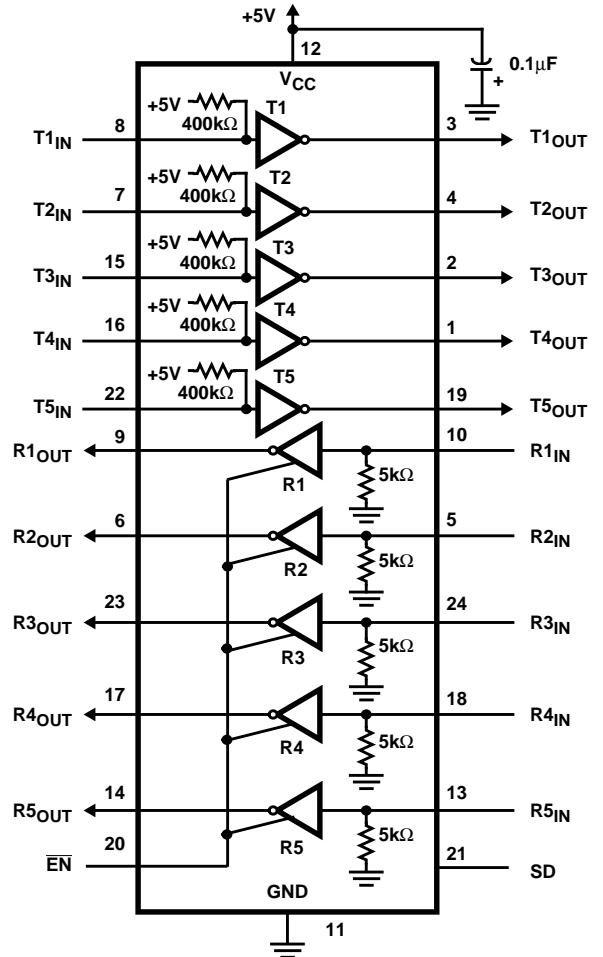
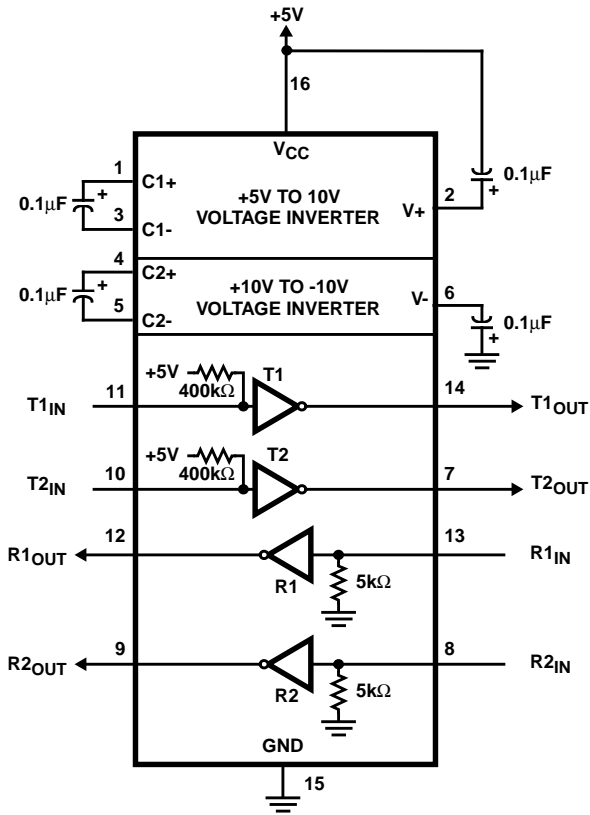
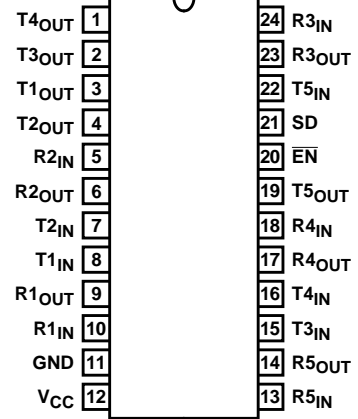

# HIN202A thru HIN241A

## Pinouts (Continued)

HIN206A (PDIP, SOIC, SSOP)  
TOP VIEW

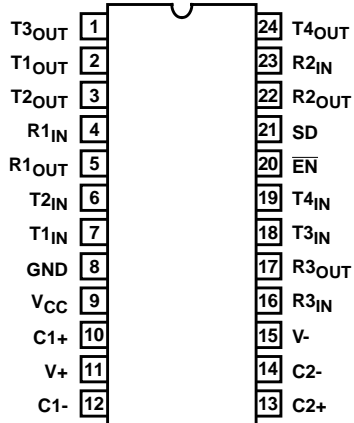

HIN207A (PDIP, SOIC, SSOP)  
TOP VIEW

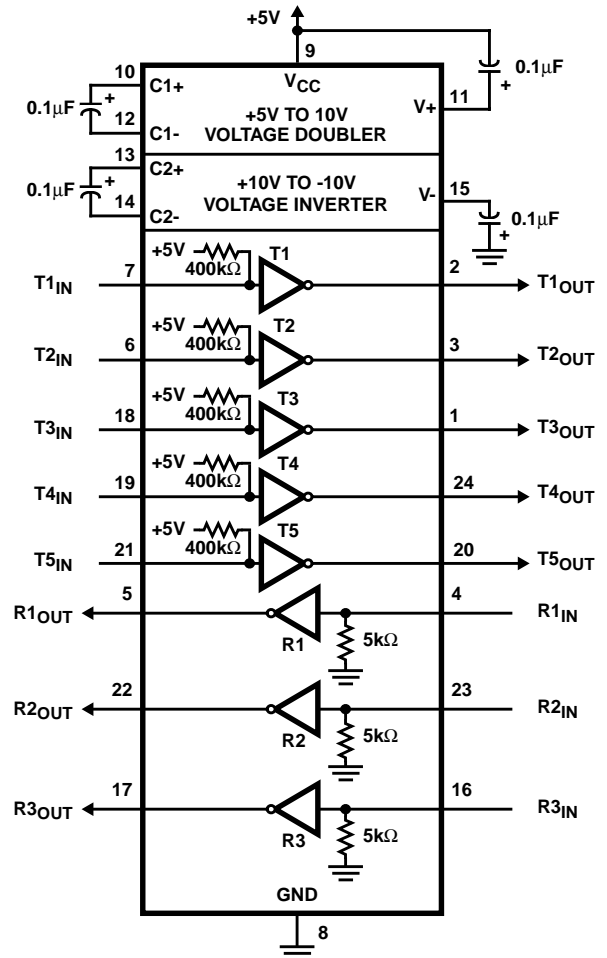
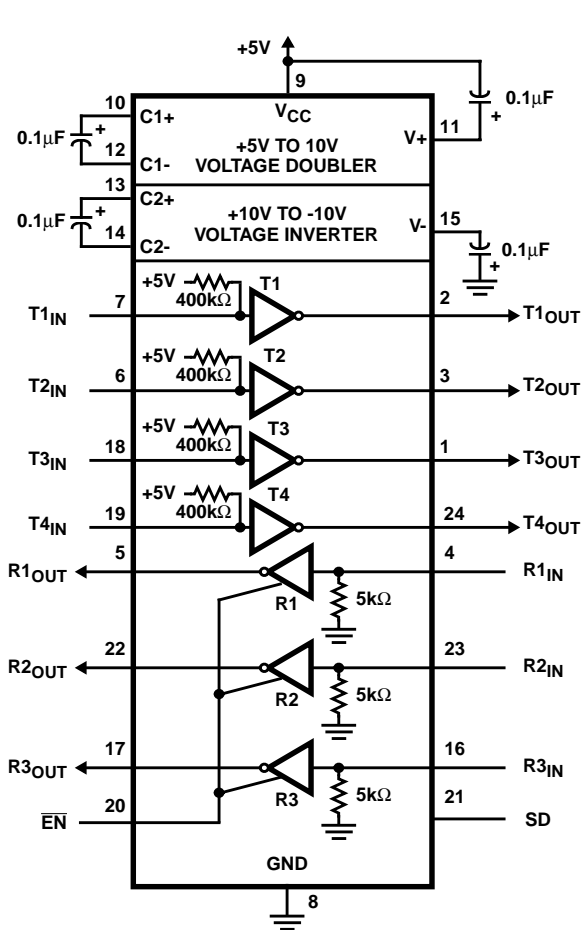
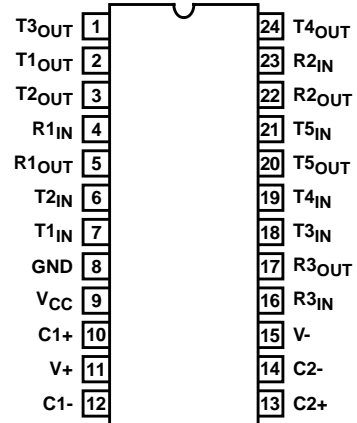

Pinouts (Continued)

HIN208A (PDIP, SOIC, SSOP)  
TOP VIEW

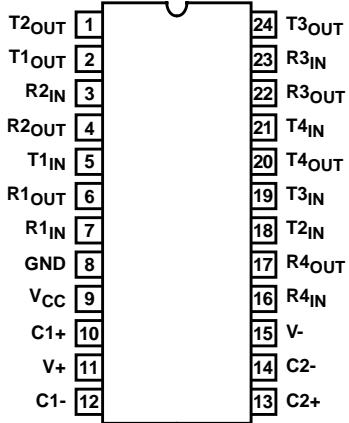

HIN211A (SOIC, SSOP)  
TOP VIEW

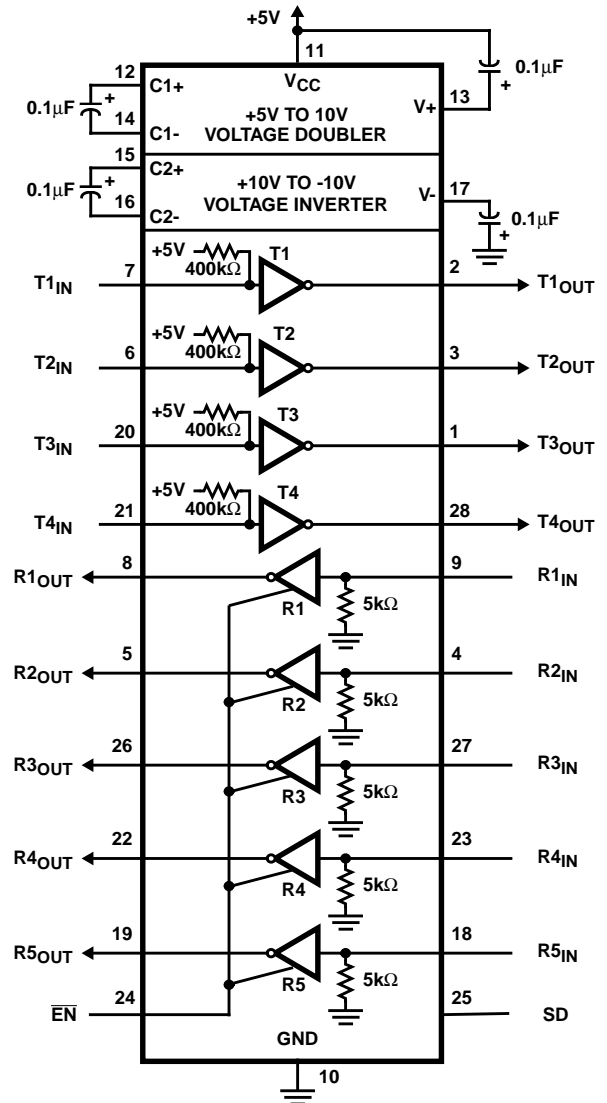
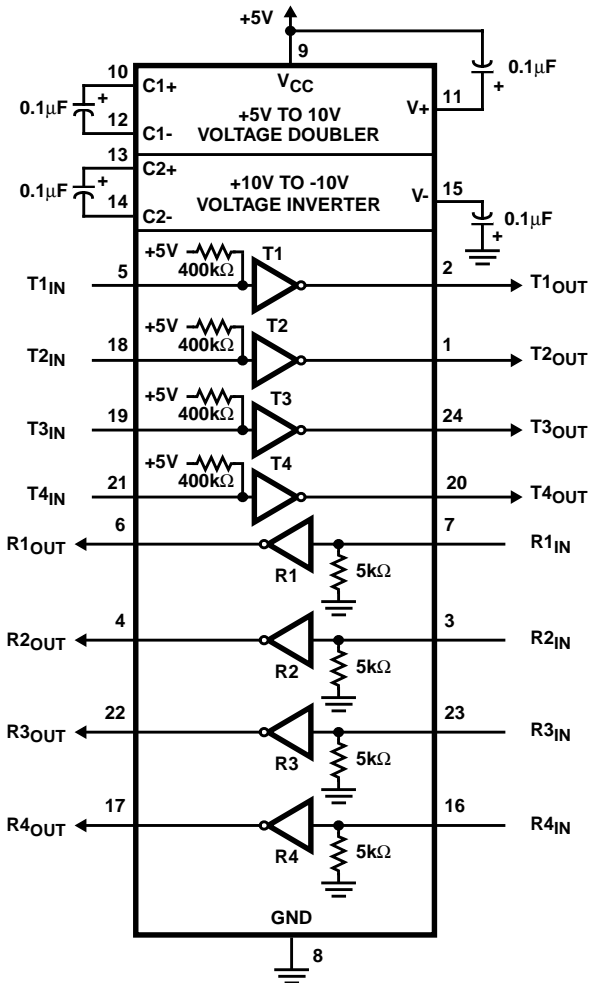
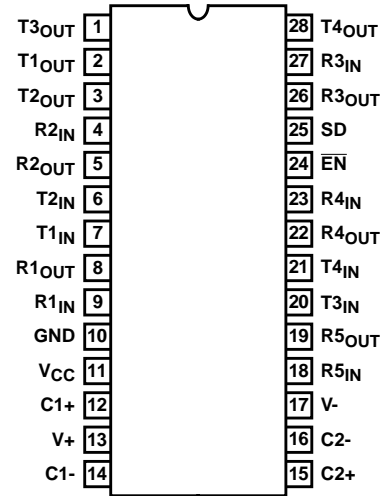

# HIN202A thru HIN241A

## Pinouts (Continued)

HIN213A (SOIC, SSOP)  
TOP VIEW

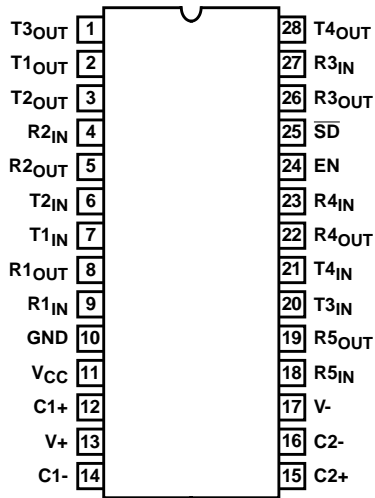

HIN232A (PDIP, SOIC)  
TOP VIEW

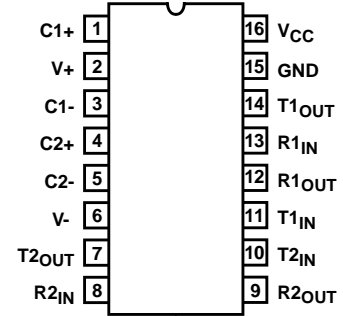

NOTE: R4 and R5 active in shutdown.

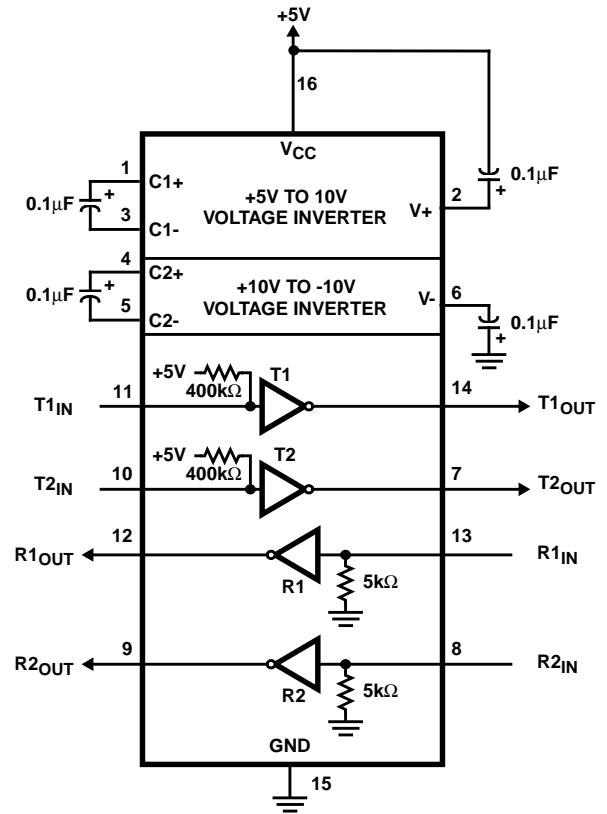
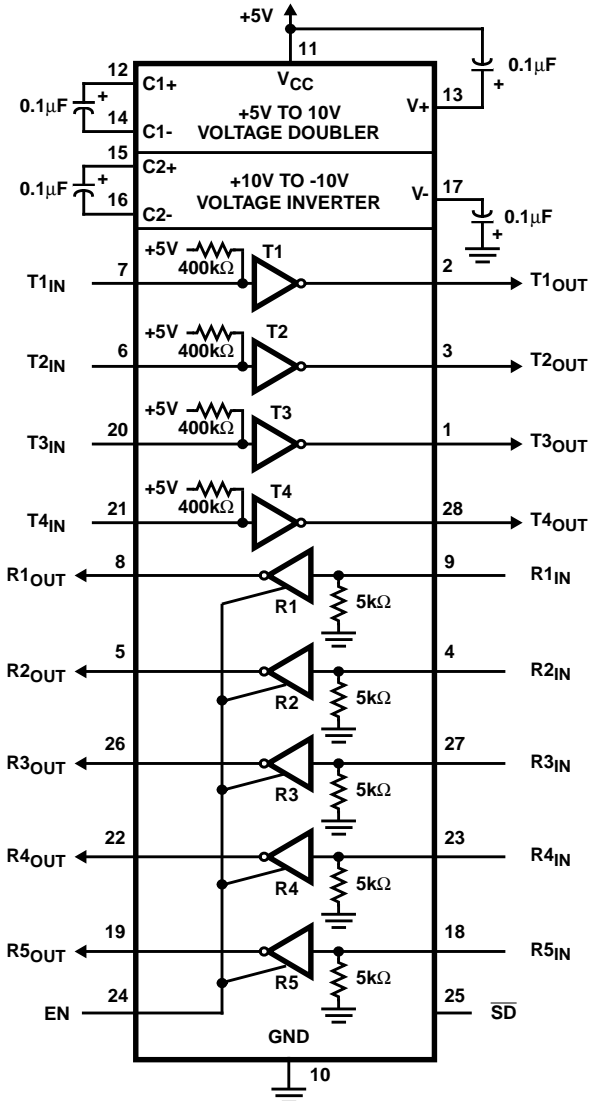

# HIN202A thru HIN241A

## Pinouts (Continued)

HIN235A (PDIP)  
TOP VIEW

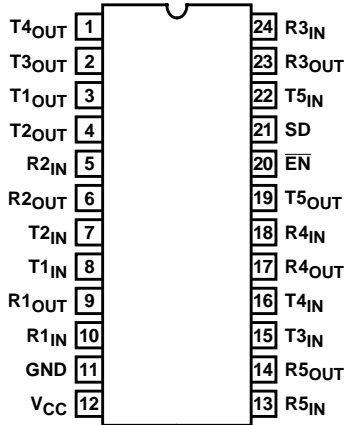

HIN236A (PDIP, SOIC, SSOP)  
TOP VIEW

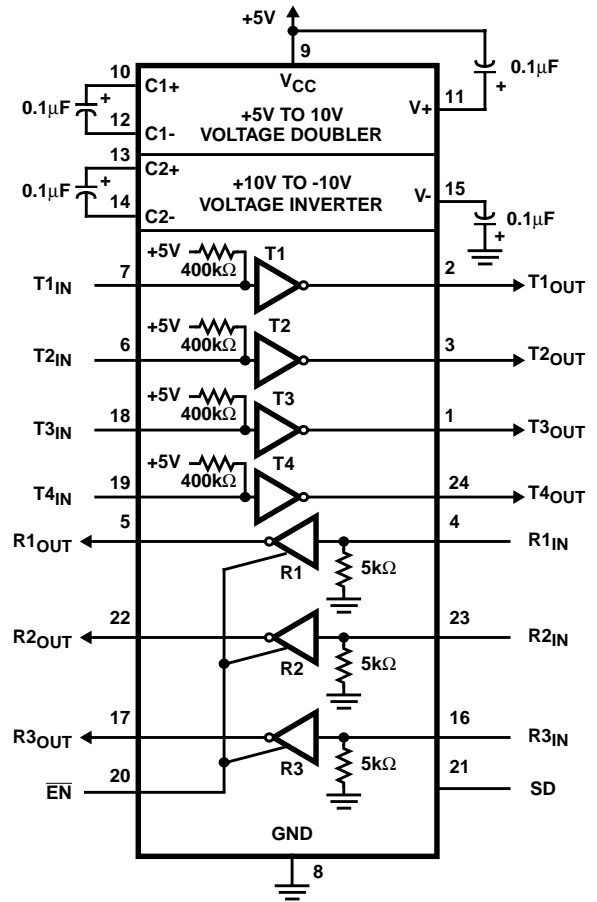
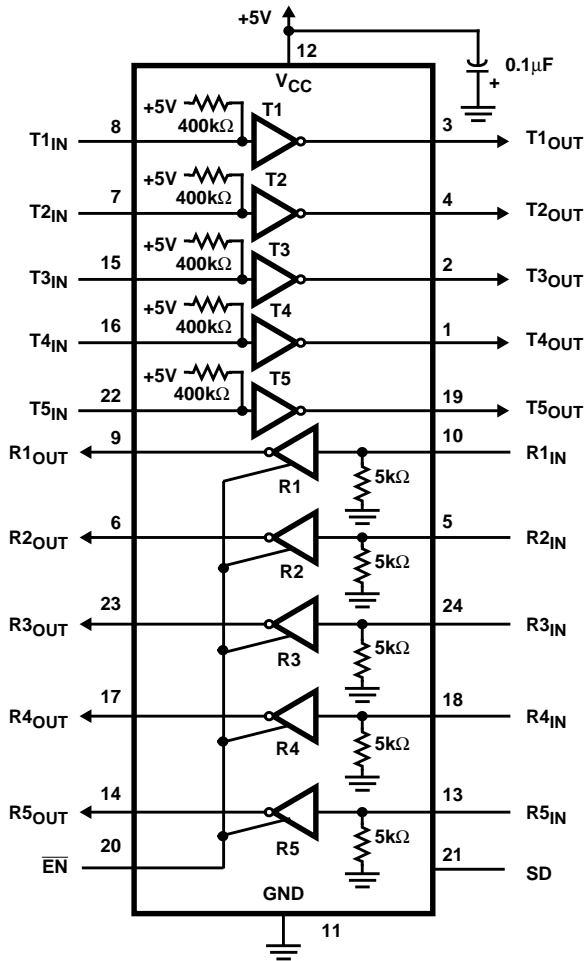
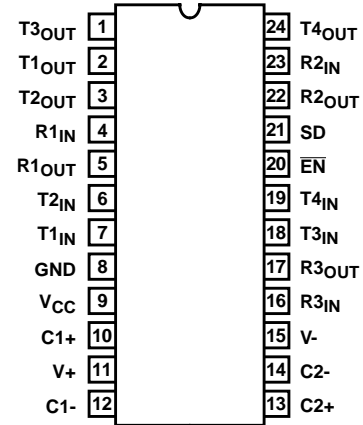

# HIN202A thru HIN241A

## Pinouts (Continued)

HIN237A (PDIP, SOIC, SSOP)  
TOP VIEW

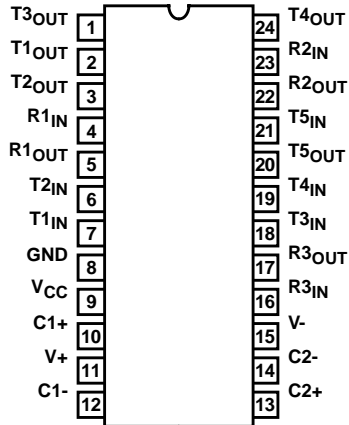

HIN238A (PDIP, SOIC, SSOP)  
TOP VIEW

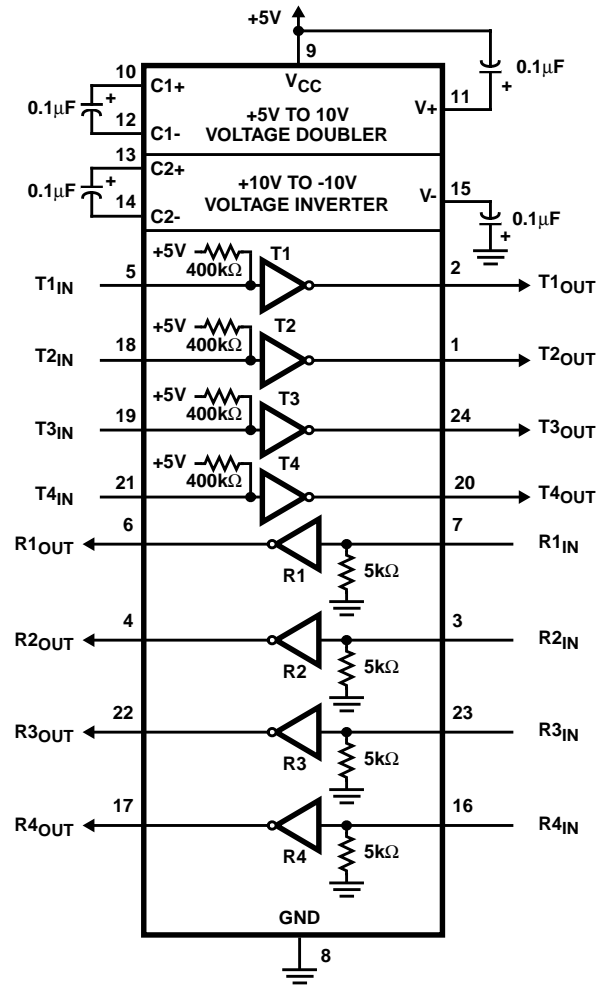
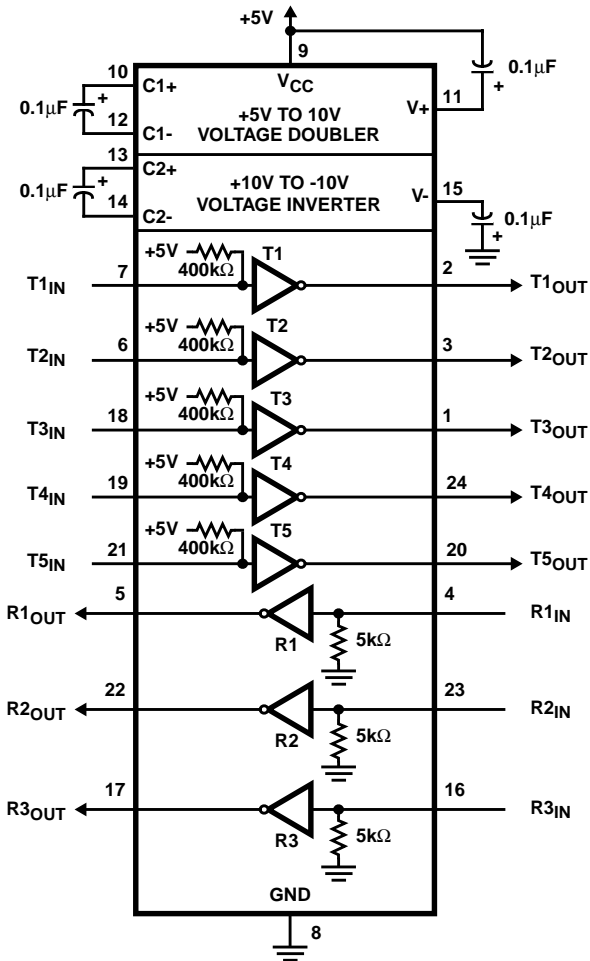
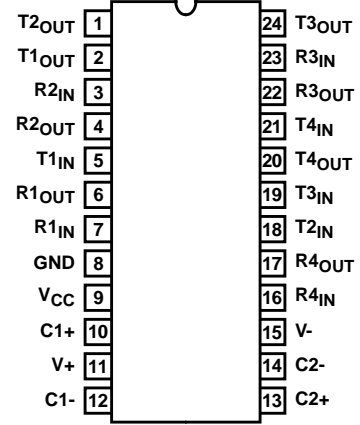

# HIN202A thru HIN241A

## Pinouts (Continued)

HIN241A (SOIC, SSOP)  
TOP VIEW

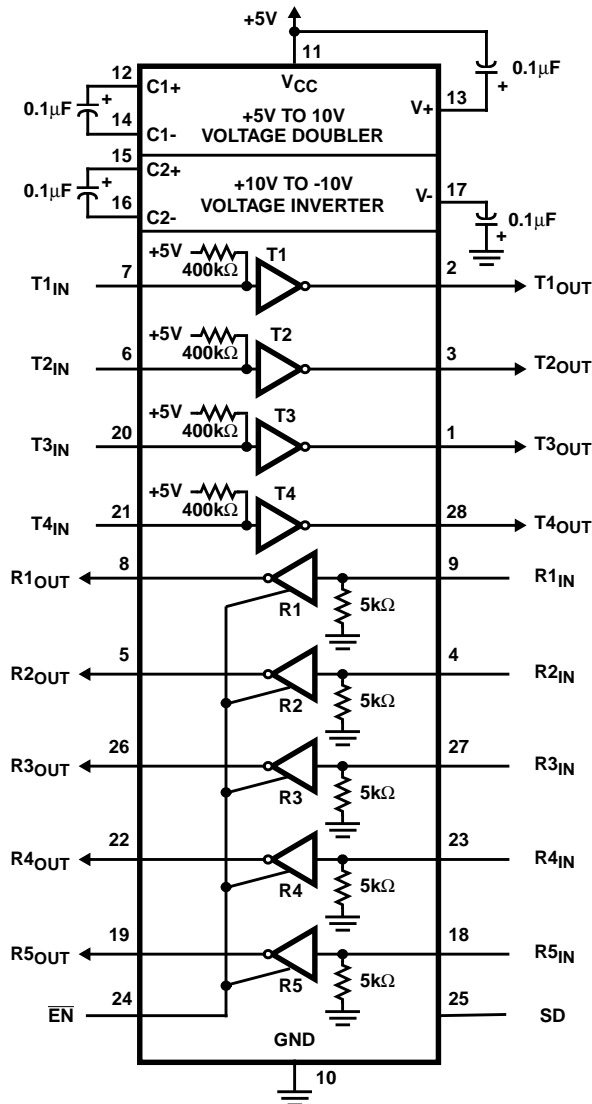
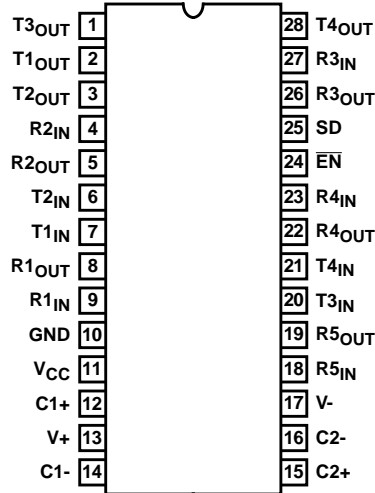

**Pin Descriptions**

PIN	FUNCTION
V <sub>CC</sub>	Power Supply Input 5V ±10%, (5V ±5% HIN207A).
V+	Internally generated positive supply (+10V nominal).
V-	Internally generated negative supply (-10V nominal).
GND	Ground Lead. Connect to 0V.
C1+	External capacitor (+ terminal) is connected to this lead.
C1-	External capacitor (- terminal) is connected to this lead.
C2+	External capacitor (+ terminal) is connected to this lead.
C2-	External capacitor (- terminal) is connected to this lead.
T <sub>IN</sub>	Transmitter Inputs. These leads accept TTL/CMOS levels. An internal 400kΩ pull-up resistor to V <sub>CC</sub> is connected to each lead.
T <sub>OUT</sub>	Transmitter Outputs. These are RS-232 levels (nominally ±10V).
R <sub>IN</sub>	Receiver Inputs. These inputs accept RS-232 input levels. An internal 5kΩ pull-down resistor to GND is connected to each input.
R <sub>OUT</sub>	Receiver Outputs. These are TTL/CMOS levels.
$\overline{EN}$	Enable Input. This is an active low input which enables the receiver outputs. With $\overline{EN} = 5V$ , the outputs are placed in a high impedance state.
SD, $\overline{SD}$	Shutdown Input. With SD = 5V (HIN213A $\overline{SD} = 0V$ ), the charge pump is disabled, the receiver outputs are in a high impedance state (except R4 and R5 of HIN241A) and the transmitters are shut off.
NC	No Connect. No connections are made to these leads.

# HIN202A thru HIN241A

## Absolute Maximum Ratings

$V_{CC}$ to Ground	(GND -0.3V) < $V_{CC}$ < 6V
V+ to Ground	( $V_{CC}$ -0.3V) < V+ < 12V
V- to Ground	-12V < V- < (GND +0.3V)
Input Voltages	
$T_{IN}$	(V- -0.3V) < $V_{IN}$ < (V+ +0.3V)
$R_{IN}$	$\pm 30V$
Output Voltages	
$T_{OUT}$	(V- -0.3V) < $V_{TXOUT}$ < (V+ +0.3V)
$R_{OUT}$	(GND -0.3V) < $V_{RXOUT}$ < (V+ +0.3V)
Short Circuit Duration	
$T_{OUT}$	Continuous
$R_{OUT}$	Continuous
ESD Classification	See Specification Table

## Operating Conditions

Temperature Range	
HIN2XXCX	0°C to 70°C

**CAUTION:** Stresses above those listed in "Absolute Maximum Ratings" may cause permanent damage to the device. This is a stress only rating and operation of the device at these or any other conditions above those indicated in the operational sections of this specification is not implied.

### NOTE:

- $\theta_{JA}$  is measured with the component mounted on an evaluation PC board in free air.

## Thermal Information

Thermal Resistance (Typical, Note 1)	$\theta_{JA}$ (°C/W)
16 Ld SOIC (N) Package	110
16 Ld SOIC (W) Package	100
16 Ld SSOP Package	155
16 Ld PDIP Package	90
24 Ld SOIC Package	75
24 Ld SSOP Package	135
24 Ld PDIP (N) Package	70
24 Ld PDIP (W) Package	55
28 Ld SOIC Package	70
28 Ld SSOP Package	100
Maximum Junction Temperature (Plastic Package)	150°C
Maximum Storage Temperature	-65°C to 150°C
Maximum Lead Temperature (Soldering 10s)	300°C
(SOIC and SSOP - Lead Tips Only)	

**Electrical Specifications** Test Conditions:  $V_{CC} = +5V \pm 10\%$ , ( $V_{CC} = +5V \pm 5\%$  HIN207A); C1-C4 = 0.1 $\mu$ F;  $T_A$  = Operating Temperature Range

PARAMETER	TEST CONDITIONS	MIN	TYP	MAX	UNITS	
<b>SUPPLY CURRENTS</b>						
Power Supply Current, $I_{CC}$	No Load, $T_A = 25^\circ C$	HIN202A	-	8	15	mA
		HIN205A-HIN208A, HIN211A, HIN213A, HIN234A-HIN238A, HIN241A	-	11	20	mA
		HIN232A	-	5	10	mA
Shutdown Supply Current, $I_{CC}(SD)$	$T_A = 25^\circ C$	HIN205A, HIN206A, HIN211A, HIN235A, HIN236A, HIN241A	-	1	10	$\mu$ A
		HIN213A	-	15	50	$\mu$ A
<b>LOGIC AND TRANSMITTER INPUTS, RECEIVER OUTPUTS</b>						
Input Logic Low, $V_{IL}$	$T_{IN}, \overline{EN}, SD, EN, \overline{SD}$	-	-	0.8	V	
Input Logic High, $V_{IH}$	$T_{IN}$	2.0	-	-	V	
	$\overline{EN}, SD, EN, \overline{SD}$	2.4	-	-	V	
Transmitter Input Pullup Current, $I_p$	$T_{IN} = 0V$	-	15	200	$\mu$ A	
TTL/CMOS Receiver Output Voltage Low, $V_{OL}$	$I_{OUT} = 1.6mA$ (HIN202A, HIN232A, $I_{OUT} = 3.2mA$ )	-	0.1	0.4	V	
TTL/CMOS Receiver Output Voltage High, $V_{OH}$	$I_{OUT} = -1mA$	3.5	4.6	-	V	
TTL/CMOS Receiver Output Leakage	$\overline{EN} = V_{CC}, EN = 0, 0V < R_{OUT} < V_{CC}$	-	0.5	$\pm 10$	$\mu$ A	
<b>RECEIVER INPUTS</b>						
RS-232 Input Voltage Range, $V_{IN}$		-30	-	+30	V	
Receiver Input Impedance, $R_{IN}$	$T_A = 25^\circ C, V_{IN} = \pm 3V$	3.0	5.0	7.0	k $\Omega$	

## HIN202A thru HIN241A

**Electrical Specifications** Test Conditions:  $V_{CC} = +5V \pm 10\%$ , ( $V_{CC} = +5V \pm 5\%$  HIN207A);  $C1-C4 = 0.1\mu F$ ;  $T_A =$  Operating Temperature Range **(Continued)**

PARAMETER	TEST CONDITIONS	MIN	TYP	MAX	UNITS	
Receiver Input Low Threshold, $V_{IN}$ (H-L)	$V_{CC} = 5V$ , $T_A = 25^\circ C$	Active Mode	-	1.2	-	V
		Shutdown Mode HIN213A R4 and R5	-	1.5	-	V
Receiver Input High Threshold, $V_{IN}$ (L-H)	$V_{CC} = 5V$ , $T_A = 25^\circ C$	Active Mode	-	1.7	2.4	V
		Shutdown Mode HIN213A R4 and R5	-	1.5	2.4	V
Receiver Input Hysteresis, $V_{HYST}$	$V_{CC} = 5V$ No Hysteresis in Shutdown Mode	0.2	0.5	1.0	V	
<b>TIMING CHARACTERISTICS</b>						
Output Enable Time, $t_{EN}$	HIN205A, HIN206A, HIN211A, HIN213A, HIN235A, HIN236A, HIN241A	-	600	-	ns	
Output Disable Time, $t_{DIS}$	HIN205A, HIN206A, HIN211A, HIN213A, HIN235A, HIN236A, HIN241A	-	200	-	ns	
Transmitter, Receiver Propagation Delay, $t_{PD}$	HIN213A $\overline{SD} = 0V$ , R4, R5	-	4.0	40	$\mu s$	
	HIN213A $\overline{SD} = V_{CC}$ , R1 - R5	-	0.5	10	$\mu s$	
	All except HIN213A	-	0.5	10	$\mu s$	
Transition Region Slew Rate, $SR_T$	$R_L = 3k\Omega$ , $C_L = 1000pF$ Measured from +3V to -3V or -3V to +3V (Note 2) 1 Transmitter Switching	3	20	45	V/ $\mu s$	
<b>TRANSMITTER OUTPUTS</b>						
Output Voltage Swing, $T_{OUT}$	Transmitter Outputs, $3k\Omega$ to Ground	$\pm 5$	$\pm 9$	$\pm 10$	V	
Output Resistance, $R_{OUT}$	$V_{CC} = V+ = V- = 0V$ , $V_{OUT} = \pm 2V$	300	-	-	$\Omega$	
RS-232 Output Short Circuit Current, $I_{SC}$	$T_{OUT}$ Shorted to GND	-	$\pm 10$	-	mA	
<b>ESD PERFORMANCE</b>						
RS-232 Pins ( $T_{OUT}$ , $R_{IN}$ )	Human Body Model	-	$\pm 15$	-	kV	
	IEC1000-4-2 Contact Discharge	-	$\pm 8$	-	kV	
	IEC1000-4-2 Air Gap (Note 3)	-	$\pm 15$	-	kV	
All Other Pins	Human Body Model	-	$\pm 2$	-	kV	

**NOTES:**

2. Guaranteed by design.
3. Meets level 4 with exception of HIN205A  $T_{5OUT} = \pm 12kV$ .

Test Circuits (HIN232A)

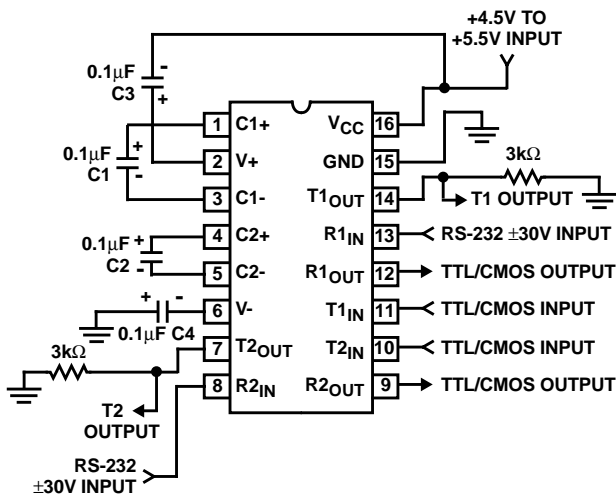

FIGURE 1. GENERAL TEST CIRCUIT

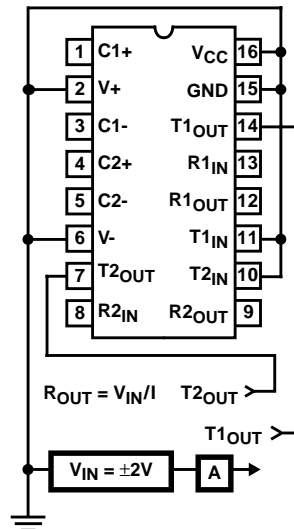

FIGURE 2. POWER-OFF SOURCE RESISTANCE CONFIGURATION

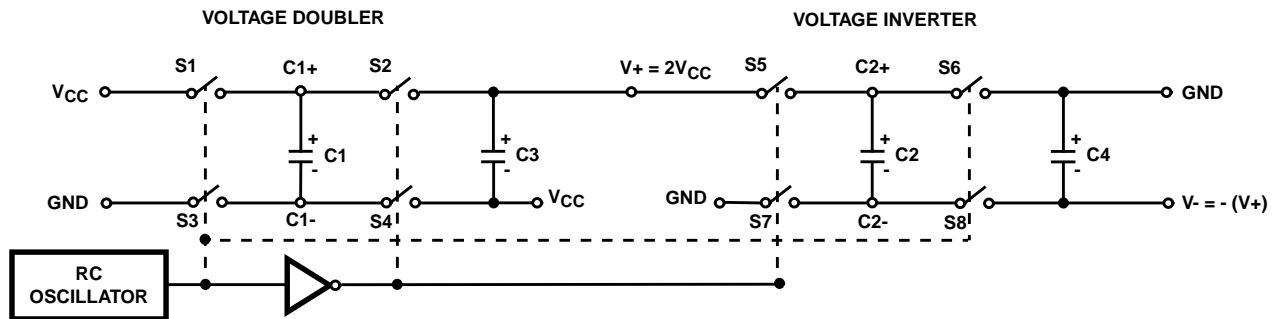

FIGURE 3. CHARGE PUMP

Detailed Description

The HIN2XXA family of high-speed RS-232 transmitters/receivers are powered by a single +5V power supply, feature low power consumption, and meet all EIA RS232C and V.28 specifications. The circuit is divided into three sections: the charge pump, transmitter, and receiver.

Charge Pump

An equivalent circuit of the charge pump is illustrated in Figure 3. The charge pump contains two sections: The voltage doubler and the voltage inverter. Each section is driven by a two phase, internally generated clock to generate +10V and -10V. The nominal clock frequency is 125kHz. During phase one of the clock, capacitor C1 is charged to V<sub>CC</sub>. During phase two, the voltage on C1 is added to V<sub>CC</sub>, producing a signal across C3 equal to twice V<sub>CC</sub>. During phase two, C2 is also charged to 2V<sub>CC</sub>, and then during phase one, it is inverted with respect to ground to produce a signal across C4 equal to -2V<sub>CC</sub>. The charge pump accepts input voltages up to 5.5V. The output impedance of the

voltage doubler section (V<sub>+</sub>) is approximately 200Ω, and the output impedance of the voltage inverter section (V<sub>-</sub>) is approximately 450Ω. A typical application uses 0.1µF capacitors for C1-C4, however, the value is not critical. Increasing the values of C1 and C2 will lower the output impedance of the voltage doubler and inverter, increasing the values of the reservoir capacitors, C3 and C4, lowers the ripple on the V<sub>+</sub> and V<sub>-</sub> supplies.

During shutdown mode (HIN205A, HIN206A, HIN211A, HIN213A, HIN235A, HIN236A and HIN241A, the charge pump is turned off, V<sub>+</sub> is pulled down to V<sub>CC</sub>, V<sub>-</sub> is pulled up to GND, and the supply current is reduced to less than 10µA. The transmitter outputs are disabled and the receiver outputs (except for HIN213A, R4 and R5) are placed in the high impedance state.

**Transmitters**

The transmitters are TTL/CMOS compatible inverters which translate the inputs to RS-232 outputs. The input logic threshold is about 26% of  $V_{CC}$ , or 1.3V for  $V_{CC} = 5V$ . A logic 1 at the input results in a voltage of between -5V and  $V^-$  at the output, and a logic 0 results in a voltage between +5V and  $(V^+ - 0.6V)$ . Each transmitter input has an internal 400k $\Omega$  pullup resistor so any unused input can be left unconnected and its output remains in its low state. The output voltage swing meets the RS-232C specifications of  $\pm 5V$  minimum with the worst case conditions of: all transmitters driving 3k $\Omega$  minimum load impedance,  $V_{CC} = 4.5V$ , and maximum allowable operating temperature. The transmitters have an internally limited output slew rate which is less than 30V/ $\mu s$ . The outputs are short circuit protected and can be shorted to ground indefinitely. The powered down output impedance is a minimum of 300 $\Omega$  with  $\pm 2V$  applied to the outputs and  $V_{CC} = 0V$ .

**Receivers**

The receiver inputs accept up to  $\pm 30V$  while presenting the required 3k $\Omega$  to 7k $\Omega$  input impedance even if the power is off ( $V_{CC} = 0V$ ). The receivers have a typical input threshold of 1.3V which is within the  $\pm 3V$  limits, known as the transition region, of the RS-232 specifications. The receiver output is 0V to  $V_{CC}$ . The output will be low whenever the input is greater than 2.4V and high whenever the input is floating or driven between +0.8V and -30V. The receivers feature 0.5V hysteresis (except during shutdown) to improve noise rejection. The receiver Enable line  $\overline{EN}$ , (EN on HIN213A) when unasserted, disables the receiver outputs, placing them in the high impedance mode. The receiver outputs are also placed in the high impedance state when in shutdown mode (except HIN213A R4 and R5).

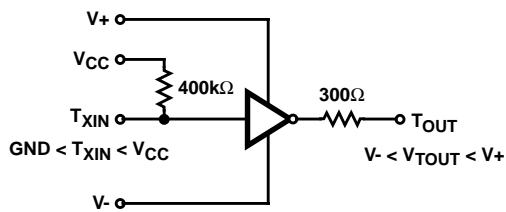

FIGURE 4. TRANSMITTER

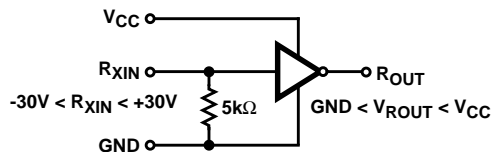
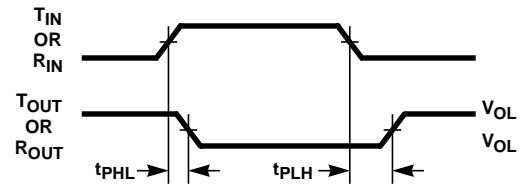

FIGURE 5. RECEIVER



$$\text{AVERAGE PROPAGATION DELAY} = \frac{t_{PHL} + t_{PLH}}{2}$$

FIGURE 6. PROPAGATION DELAY DEFINITION

**HIN241A Operation in Shutdown**

The HIN213A features two receivers, R4 and R5, which remain active in shutdown mode. During normal operation the receivers propagation delay is typically 0.5 $\mu s$ . This propagation delay may increase slightly during shutdown. When entering shut down mode, receivers R4 and R5 are not valid for 80 $\mu s$  after  $\overline{SD} = V_{IL}$ . When exiting shutdown mode, all receiver outputs will be invalid until the charge pump circuitry reaches normal operating voltage. This is typically less than 2ms when using 0.1 $\mu F$  capacitors.

**Application Information**

The HIN2XXA may be used for all RS-232 data terminal and communication links. It is particularly useful in applications where  $\pm 12V$  power supplies are not available for conventional RS-232 interface circuits. The applications presented represent typical interface configurations.

A simple duplex RS-232 port with CTS/RTS handshaking is illustrated in Figure 7. Fixed output signals such as DTR (data terminal ready) and DSRS (data signaling rate select) is generated by driving them through a 5k $\Omega$  resistor connected to  $V^+$ .

In applications requiring four RS-232 inputs and outputs (Figure 8), note that each circuit requires two charge pump capacitors (C1 and C2) but can share common reservoir capacitors (C3 and C4). The benefit of sharing common reservoir capacitors is the elimination of two capacitors and the reduction of the charge pump source impedance which effectively increases the output swing of the transmitters.

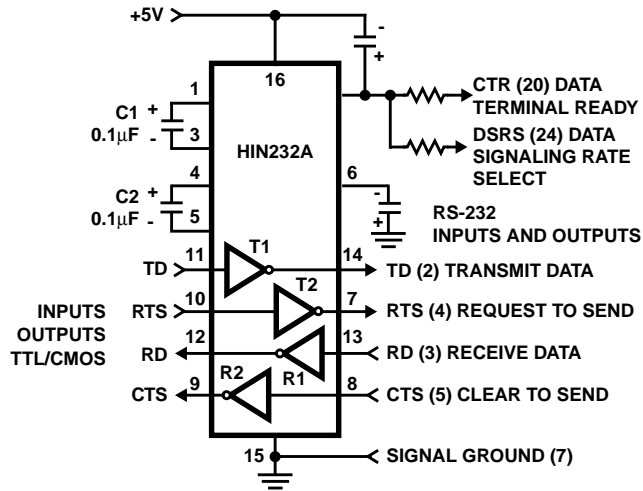

FIGURE 7. SIMPLE DUPLEX RS-232 PORT WITH CTS/RTS HANDSHAKING

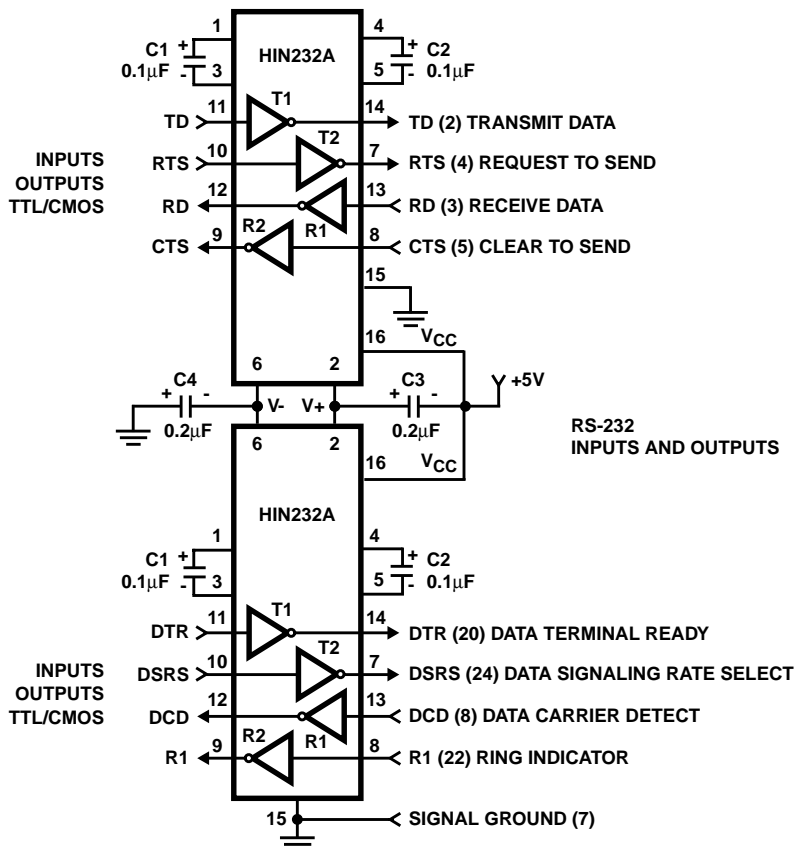

FIGURE 8. COMBINING TWO HIN232As FOR 4 PAIRS OF RS-232 INPUTS AND OUTPUTS

**Typical Performance Curves**

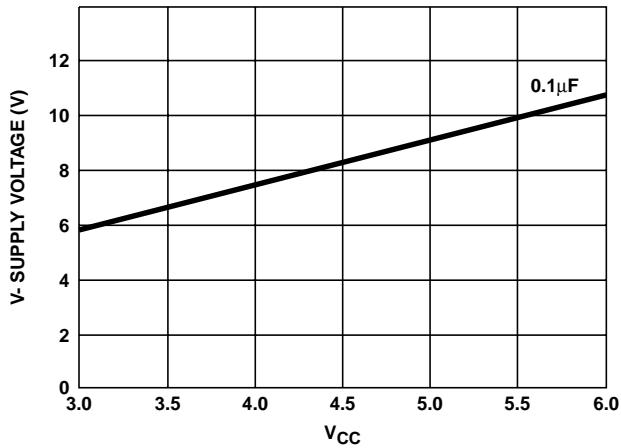

FIGURE 9. V- SUPPLY VOLTAGE vs VCC

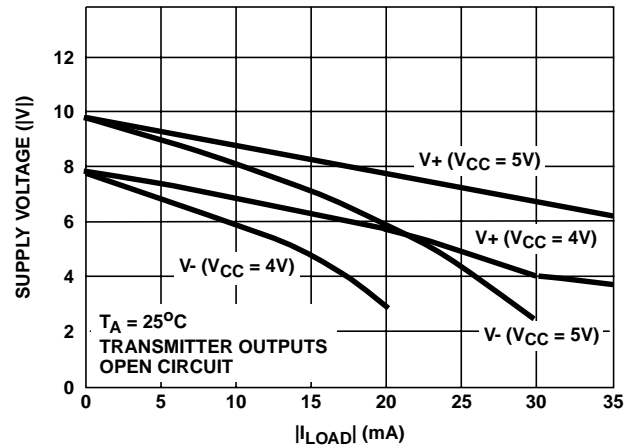

FIGURE 10. V+, V- OUTPUT VOLTAGE vs LOAD

**Die Characteristics**

**DIE DIMENSIONS:**

160 mils x 140 mils

**METALLIZATION:**

Type: Al  
Thickness:  $10\text{k}\text{\AA} \pm 1\text{k}\text{\AA}$

**SUBSTRATE POTENTIAL**

V+

**PASSIVATION:**

Type: Nitride over Silox  
Nitride Thickness:  $8\text{k}\text{\AA}$   
Silox Thickness:  $7\text{k}\text{\AA}$

**TRANSISTOR COUNT:**

238

**PROCESS:**

CMOS Metal Gate

**Metallization Mask Layout**

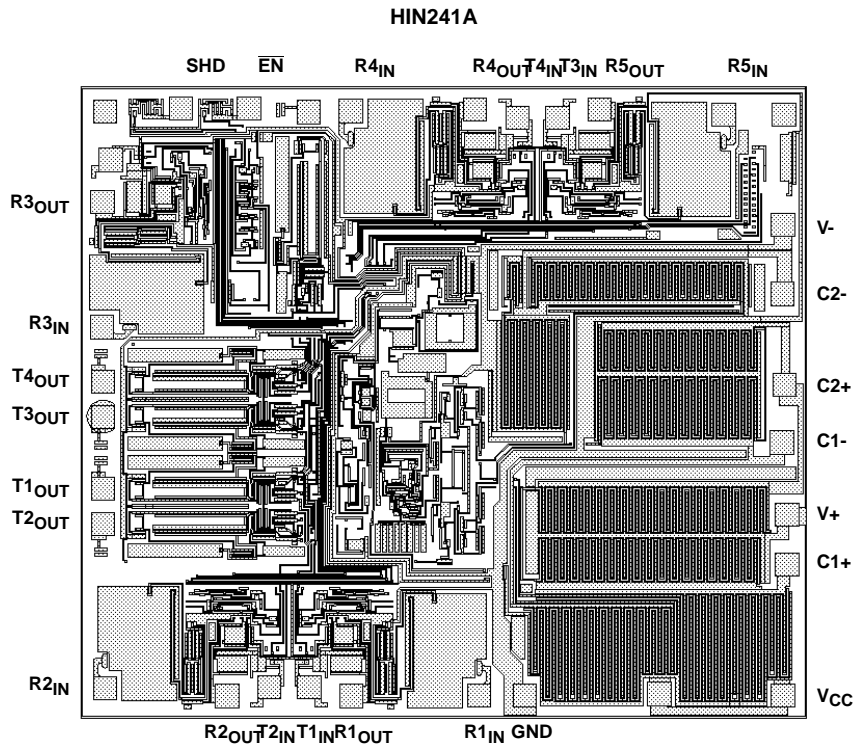

All Intersil semiconductor products are manufactured, assembled and tested under **ISO9000** quality systems certification.

*Intersil semiconductor products are sold by description only. Intersil Corporation reserves the right to make changes in circuit design and/or specifications at any time without notice. Accordingly, the reader is cautioned to verify that data sheets are current before placing orders. Information furnished by Intersil is believed to be accurate and reliable. However, no responsibility is assumed by Intersil or its subsidiaries for its use; nor for any infringements of patents or other rights of third parties which may result from its use. No license is granted by implication or otherwise under any patent or patent rights of Intersil or its subsidiaries.*

For information regarding Intersil Corporation and its products, see web site **www.intersil.com**

### **Sales Office Headquarters**

#### **NORTH AMERICA**

Intersil Corporation  
P. O. Box 883, Mail Stop 53-204  
Melbourne, FL 32902  
TEL: (321) 724-7000  
FAX: (321) 724-7240

#### **EUROPE**

Intersil SA  
Mercure Center  
100, Rue de la Fusee  
1130 Brussels, Belgium  
TEL: (32) 2.724.2111  
FAX: (32) 2.724.22.05

#### **ASIA**

Intersil (Taiwan) Ltd.  
7F-6, No. 101 Fu Hsing North Road  
Taipei, Taiwan  
Republic of China  
TEL: (886) 2 2716 9310  
FAX: (886) 2 2715 3029

This datasheet has been downloaded from:

[www.DatasheetCatalog.com](http://www.DatasheetCatalog.com)

Datasheets for electronic components.



LittleDiode supplies new, hard to find or obsolete electronic components and semiconductors all over the world.

With over two million different components listed you are sure to find the part you need.

Feel free to visit us today at our online store:

[LittleDiode.com](http://LittleDiode.com)

Looking forward to providing you with the best possible service.