

7V, 17A SynchroFET™ Complementary Drive Synchronous Half-Bridge

Designed with the P6 and Pentium® in mind, the Intersil SynchroFET™ family provides a new approach for implementing a synchronous rectified buck switching regulator. The SynchroFET replaces two power DMOSs, a Schottky diode, two gate drivers and synchronous control circuitry. The complementary drive circuit turns the upper FET on and the lower FET off when the input from the PWM is high. When the input from the PWM goes low the upper FET turns off and the lower FET turns on. The HIP5011 has a PWM pin that inverts the relationship from the input to PHASE. This architecture allows the designer to utilize a low cost single-ended PWM controller in either a current or voltage mode configuration. The SynchroFET operates in continuous conduction mode reducing EMI constraints and enabling high bandwidth operation. Several features ensure easy start-up. First, the supply currents stay below specification as the supply voltages ramp up; no unexpected surges occur that might perturb a soft-start or deplete a charge-pump. Second, any power-up sequence of the V_{CC} , V_{IN} , or PWM pins can be used without causing large currents. Third, the chip operates when V_{CC} is greater than 2V so V_{CC} can be created from a charge pump powered from V_{IN} .

Pinouts

HIP5010IS1, HIP5011IS1 (SIP - VERTICAL)
TOP VIEW

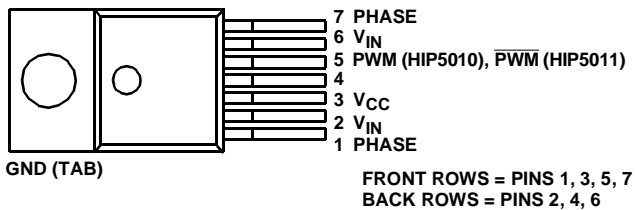

HIP5010IS, HIP5011IS (SIP - GULLWING)
TOP VIEW

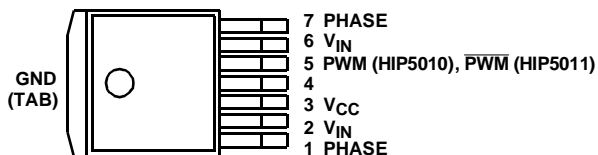

Features

- Complementary Drive, Half-Bridge Power NMOS
- Use With Low-Cost Single-Output PWM Controllers
- Improve Efficiency Over Conventional Buck Converter with Schottky Clamp
- Minimum Deadtime Provided by Adaptive Shoot-Through Protection Eliminates External Schottky
- Grounded Case for Low EMI and Simple Heatsinking
- Low Operating Current
- Frequency Exceeding 1MHz
- Dual Polarity Input Options
- All Pins Surge Protected

Applications

- 5V to $\leq 3.3V$ Synchronous Buck Converters
- Pentium and P6 Power Supplies
- PowerPC™ Power Supplies
- Bus Terminations (BTL and GTL)
- Drive 5V Motors Directly from Microprocessor

Ordering Information

PART NUMBER	TEMP. RANGE (°C)	PACKAGE	PKG. NO.
HIP5010IS	-40 to 85	7 Ld Gullwing SIP	Z7.05B
HIP5010IS1	-40 to 85	7 Ld Staggered Vertical SIP	Z7.05C
HIP5011IS	-40 to 85	7 Ld Gullwing SIP	Z7.05B
HIP5011IS1	-40 to 85	7 Ld Staggered Vertical SIP	Z7.05C

Typical Application Block Diagram

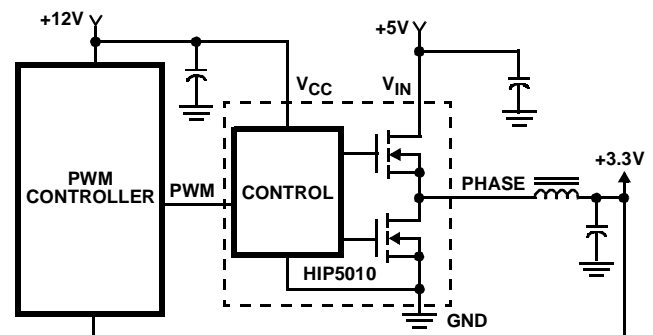

SYNCHRONOUS RECTIFIED BUCK CONVERTER

Pentium® is a registered trademark of Intel Corporation.
PowerPC™ is a trademark of International Business Machines.
SynchroFET™ is a trademark of Intersil Corporation.

Non-Inverting SynchroFET Block Diagram

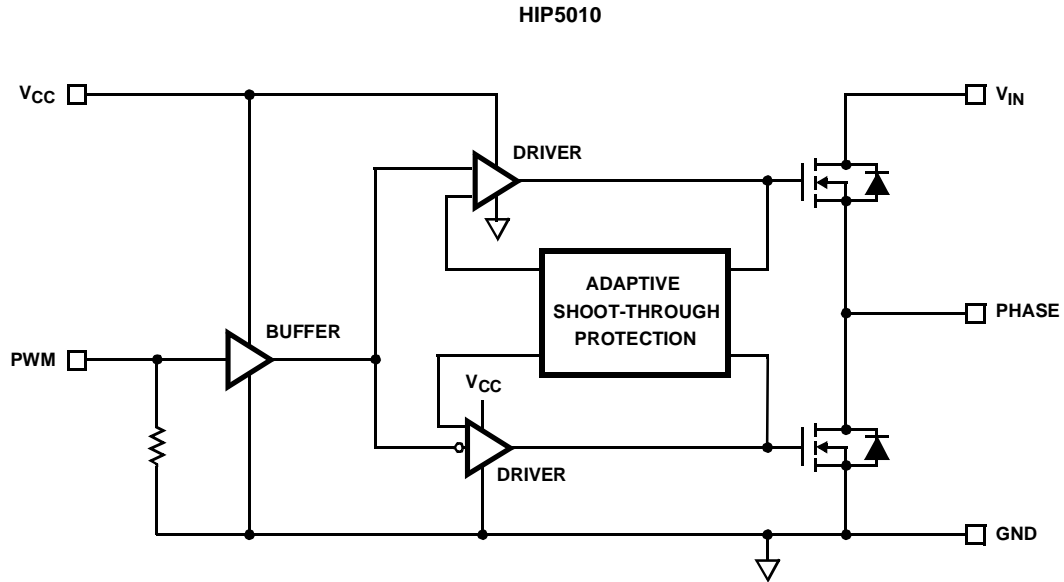

Inverting SynchroFET Block Diagram

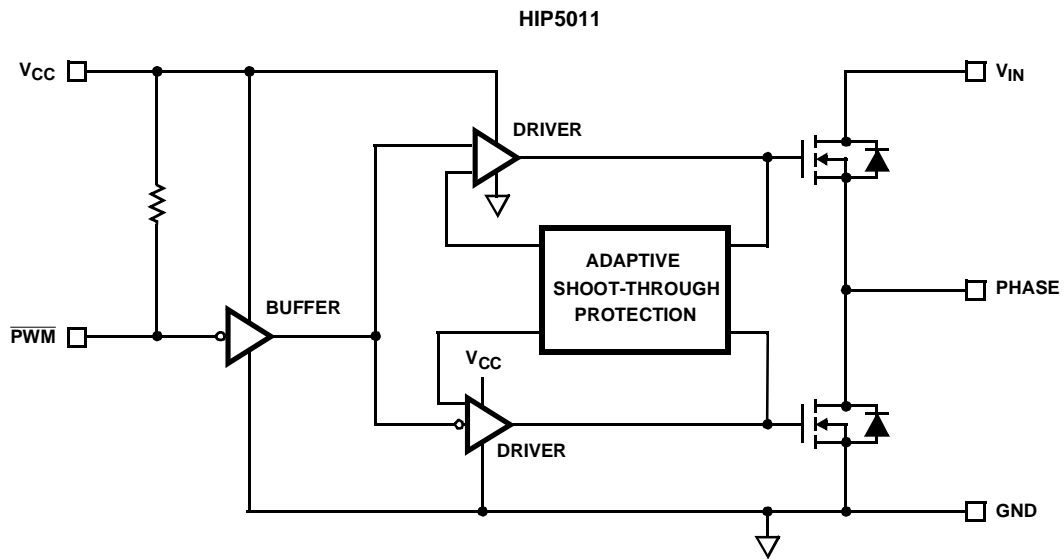

HIP5010, HIP5011

Absolute Maximum Ratings

Supply Voltage, V_{CC}	+16V
Input Voltage V_{IN}	+7V
I_{PHASE} , I_{VIN} , I_{GND} ($T_J = 25^{\circ}C$)	17A (Repetitive Peak)
I_{PHASE} , I_{VIN} , I_{GND} ($T_J = 150^{\circ}C$)	15A (Repetitive Peak)
PWM Input	-4V to +16V
ESD Classification	Class 3 (4kV)
Lead Temperature (Soldering 10s) (Lead Tips Only)	300°C
Storage Temperature Range	-65°C to 150°C
Junction Temperature Range	-40°C to 150°C

Operating Conditions

Supply Voltage, V_{CC}	+12V, $\pm 20\%$
Input Voltage V_{IN}	0V to 5.5V
Supply Voltage, V_{CC} , minimum for charge-pumped start-up	+4.0V

Thermal Information (Typical)

Package	$\theta_{JC}^{\dagger\dagger}$ (°C/W)	θ_{JA} (°C/W) [†]				
		0	1	2	3	3 ^{†††}
SOIC (IB)	26	63	45	42	41	35
SIP (IS)	2	55	30	25	24	18
SIP (IS1)	2	-	-	-	-	-

† Versus additional square inches of 1 ounce copper on the printed circuit board.

†† θ_{JC} is measured to pin 12 for the SOIC. Printed circuit board had 1 square inch of copper. For SIP Packages value shown is typical with an infinite heat sink.

††† 200 linear feet per minute of air flow.

I_{PHASE} SIPs:11.5A(RMS), 11.2A(DC); SOIC:7.4A(RMS), 7.4A(DC)
 I_{VIN} SIPs:10.0A(RMS), 8.5A(DC); SOIC:6.4A(RMS), 6.4A(DC)
 I_{GND} SIPs:8.5A(RMS), 6.0A(DC); SOIC:5.4A(RMS), 5.4A(DC)

CAUTION: Stresses above those listed in "Absolute Maximum Ratings" may cause permanent damage to the device. This is a stress only rating and operation of the device at these or any other conditions above those indicated in the recommended operating conditions of this specification is not implied.

Electrical Specifications

PARAMETERS	SYMBOL	TEST CONDITIONS	$T_J = 25^{\circ}C$			$T_J = -40^{\circ}C$ $T_J = 150^{\circ}C$		UNITS
			MIN	TYP	MAX	MIN	MAX	
$r_{DS(ON)}$ Upper MOSFET	R_{DSU}	$V_{CC} = 12V$, $V_{IN} = 5V$	-	34	39	-	65	mΩ
$r_{DS(ON)}$ Lower MOSFET	R_{DSL}	$V_{CC} = 12V$, $V_{IN} = 5V$	-	36	42	-	68	mΩ
V_{IN} Operating Current	I_{VINO}	$V_{IN} = 5V$, No Load, 500kHz	-	5	8	-	10	mA
V_{IN} Quiescent Current	I_{VIN}	PWM or $\overline{PWM} = V_{CC}$ or GND	-	0.1	10	-	100	μA
V_{CC} Operating Current	I_{CCO}	$V_{CC} = 12V$, 500kHz	-	8	12	-	15	mA
V_{CC} Quiescent Current (HIP5010)	I_{CCIH}	PWM = V_{CC}	-	80	-	-	400	μA
V_{CC} Quiescent Current (HIP5010)	I_{CCIL}	PWM = GND	-	0.1	10	-	100	μA
V_{CC} Quiescent Current (HIP5011)	I_{CCNIH}	$\overline{PWM} = V_{CC}$	-	0.1	10	-	100	μA
V_{CC} Quiescent Current (HIP5011)	I_{CCNIL}	$\overline{PWM} = GND$	-	140	-	-	400	μA
Low Level PWM Input Voltage	V_{IL}		-	1.8	-	1	-	V
High Level PWM Input Voltage	V_{IH}		-	2.1	-	-	3	V
PWM Input Voltage Hysteresis	V_{IHYS}		-	0.3	-	-	-	V
Input Pulldown Resistance (HIP5010)	R_{PWM}		-	220	-	100	400	kΩ
Input Pullup Resistance (HIP5011)	R_{PWM}		-	220	-	100	400	kΩ

Switching Specifications

PARAMETERS	SYMBOL	TEST CONDITIONS	$T_J = 25^{\circ}C$			$T_J = -40^{\circ}C$ $T_J = 150^{\circ}C$		UNITS
			MIN	TYP	MAX	MIN	MAX	
Upper Device Turn-Off Delay	t_{PHL}	$V_{CC} = 12V$, $I_{PHASE} = -1A$	-	30	50	-	80	ns
Lower Device Turn-Off Delay	t_{PLH}	$V_{CC} = 12V$, $I_{PHASE} = +1A$	-	30	50	-	80	ns
Dead Time	t_{DT}	$V_{CC} = +12V$, $I_{PHASE} = -1A$	-	10	-	-	-	ns
Phase Rise-Time	t_r	$V_{CC} = 12V$, $I_{PHASE} = -1A$	-	20	-	-	-	ns
Phase Fall-Time	t_f	$V_{CC} = 12V$, $I_{PHASE} = +1A$	-	20	-	-	-	ns

Pin Descriptions

SYMBOL	DESCRIPTION
V _{CC}	Positive supply to control logic and gate drivers. De-couple this pin to GND.
V _{IN}	FET Switch Input Voltage. De-couple this pin to GND. Tie all V _{IN} terminals together.
PHASE	Output. Tie all phase terminals together.
PWM (HIP5010) PWM (HIP5011)	Single Ended Control Input. This input connects to the PWM controller output.
GND	System Ground.

Timing Diagram

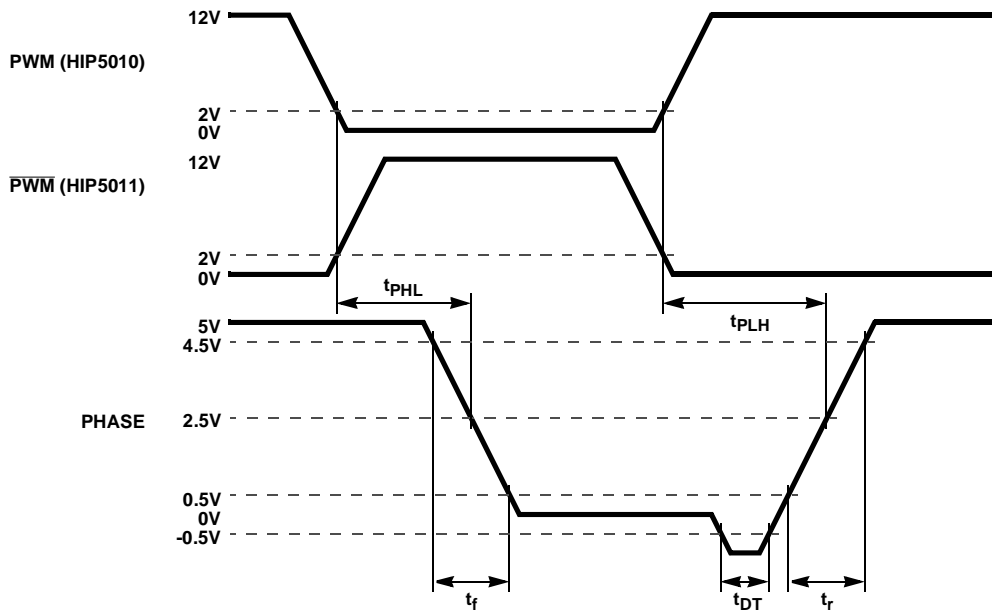

NOTE: I_{PHASE} = +1A for t_{PLH} and t_f, I_{PHASE} = -1A for t_{PHL}, t_{DT}, and t_r.

FIGURE 1.

Typical Performance Curves

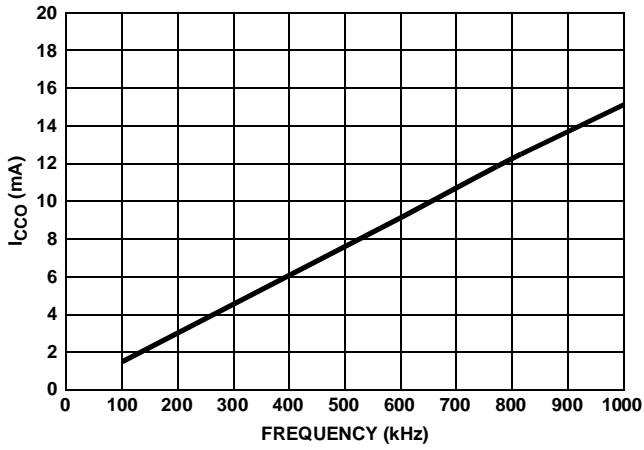

FIGURE 2. I_{CCO} vs FREQUENCY

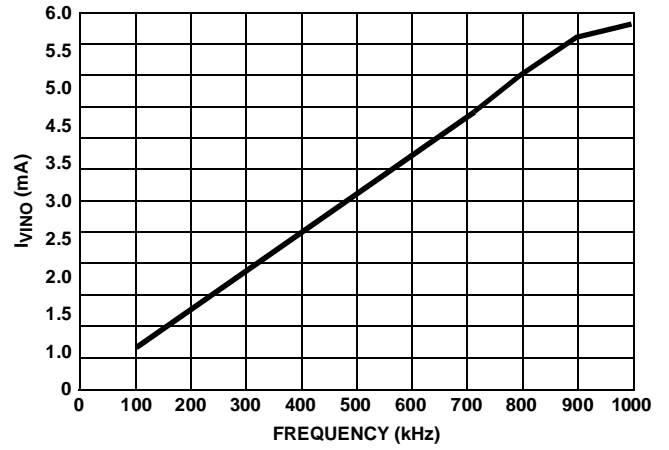

FIGURE 3. I_{VINO} vs FREQUENCY

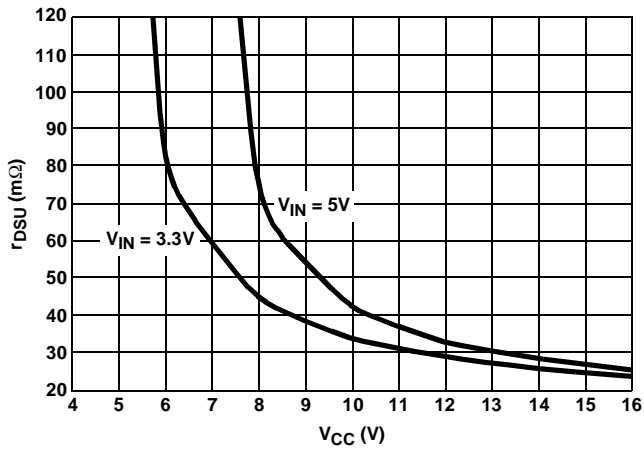

FIGURE 4. R_{DSU} vs V_{Cc}

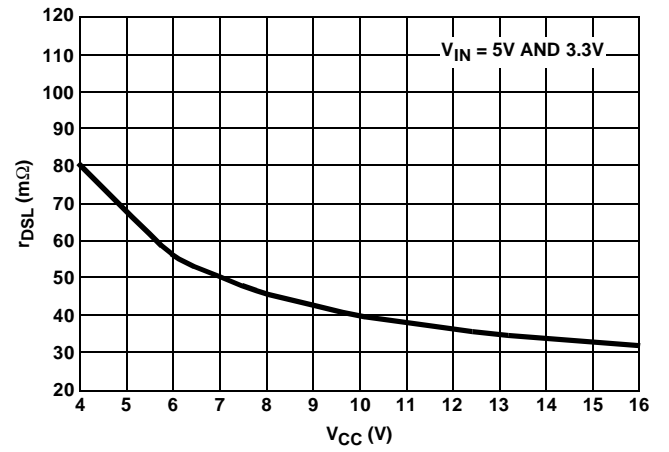

FIGURE 5. R_{DSL} vs V_{Cc}

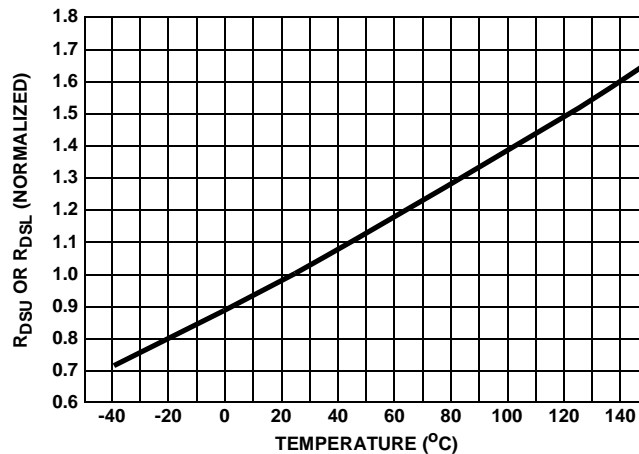
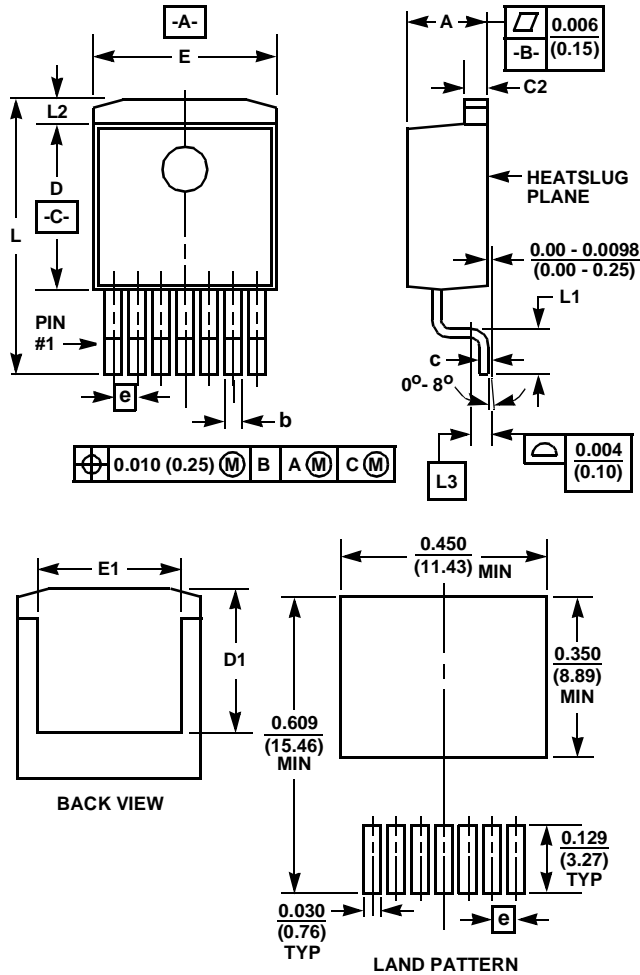

FIGURE 6. R_{DSU} OR R_{DSL} vs TEMPERATURE

Single-In-Line Plastic Packages (SIP)



Z7.05B

7 LEAD PLASTIC SINGLE-IN-LINE PACKAGE SURFACE MOUNT "GULLWING" LEAD FORM

SYMBOL	INCHES		MILLIMETERS		NOTES
	MIN	MAX	MIN	MAX	
A	0.170	0.180	4.32	4.57	-
C2	0.048	0.055	1.22	1.39	5
D	0.350	0.370	8.89	9.39	-
E	0.395	0.405	10.04	10.28	-
D1	0.310	-	7.88	-	-
E1	0.310	-	7.88	-	-
L	0.549	0.569	13.95	14.45	-
L1	0.068	0.088	1.72	2.24	-
L2	0.045	0.055	1.15	1.40	-
L3	0.030 BSC		0.76 BSC		4
b	0.028	0.034	0.71	0.86	5, 6, 7
c	0.018	0.024	0.46	0.60	5
e	0.050 BSC		1.27 BSC		-

Rev. 2 12/95

NOTES:

1. These package dimensions are within allowable dimensions of JEDEC MO-169AC, Issue A.
2. Controlling dimension: Inch.
3. Dimensioning and tolerance per ANSI Y14.5M-1982.
4. Gauge plane L3 is parallel to heatslug plane.
5. Dimensions include lead finish.
6. Leads are not allowed above the datum -B-.
7. Dimension "b" does not include dambar protrusion. Allowable dambar protrusion shall not cause the lead width to exceed the maximum "b" by more than 0.003" (0.08mm).

Single-In-Line Plastic Packages (SIP)

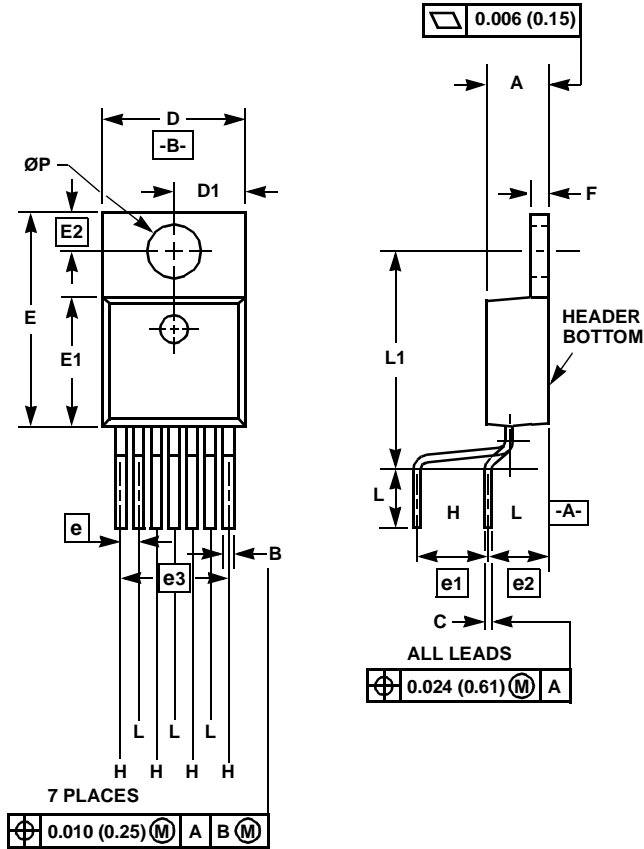

Z7.05C

7 LEAD PLASTIC SINGLE-IN-LINE PACKAGE STAGGERED VERTICAL LEAD FORM

SYMBOL	INCHES		MILLIMETERS		NOTES
	MIN	MAX	MIN	MAX	
A	0.170	0.180	4.32	4.57	-
B	0.028	0.034	0.71	0.86	3, 4
C	0.018	0.024	0.46	0.60	3
D	0.395	0.405	10.04	10.28	-
D1	0.198	0.202	5.03	5.13	-
E	0.595	0.605	15.11	15.37	-
E1	0.350	0.370	8.89	9.39	-
E2	0.110 BSC		2.79 BSC		
e	0.050 BSC		1.27 BSC		-
e1	0.200 BSC		5.08 BSC		-
e2	0.169 BSC		4.29 BSC		-
e3	0.300 BSC		7.62 BSC		-
F	0.048	0.055	1.22	1.39	3
L	0.150	0.176	3.81	4.47	-
L1	0.600	0.620	15.24	15.74	-
ØP	0.147	0.152	3.73	3.86	3

Rev. 1 4/98

NOTES:

1. Controlling dimension: INCH.
2. Dimensioning and tolerancing per ANSI Y14.5M-1982.
3. Dimensions include lead finish.
4. Dimension "B" does not include dambar protrusion. Allowable dambar protrusion shall not cause lead width to exceed maximum "B" by more than 0.003 inches (0.08mm).



LittleDiode supplies new, hard to find or obsolete electronic components and semiconductors all over the world.

With over two million different components listed you are sure to find the part you need.

Feel free to visit us today at our online store:

LittleDiode.com

Looking forward to providing you with the best possible service.