

## ADVANCE INFORMATION

August 1996

## J1850 Byte Level Interface Circuit

### Features

- Fully Supports VPW (Variable Pulse Width) Messaging Practices of SAE J1850 Standard for Class B Data Communications Network Interface
  - 3-Wire, High-Speed, Synchronous, Serial Interface
- Reduces Wiring Overhead
- Directly Interfaces with 68HC05 and 68HC11 Style SPI Ports
- 1MHz, 8-Bit Transfers Between Host and HIP7010 Minimize Host Service Requirements
- Automatically Transmits Properly Framed Messages
- Prepends SOF to First Byte and Appends CRC to Last Byte
- Fail-Safe Design Including, Slow Clock Detection Circuitry, Prevents J1850 Bus Lockup Due to System Errors or Loss of Input Clock
- Automatic Collision Detection
- End of Data (EOD), Break, Idle Bus, and Invalid Symbol (Noise/Illegal Symbols) Detection
- Supports In-Frame Responses with Generation of Normalization Bits (NB) for Type 1, Type 2, and Type 3 Messages
- Wait-For-Idle Mode Reduces Host Overhead During Non-Applicable Messages
- Status Register Flags Provide Information on Current Status of J1850 Bus
- Serial I/O Pins are Active Only During Transfers - Bus Available for Other Devices 95% of the Time
- TEST Pin Provides Built-in-Test Capabilities for In-System Diagnostics and Factory Testing
- High Speed (4X) Receive Mode for Production and Diagnostic Testing/Programming
- Operates with Wide Range of Input Clock Frequencies
- Power-Saving Power-Down Mode
- Full -40°C to +125°C Operating Range
- Single 3.0V to 6.0V Supply

### Description

The Intersil HIP7010, J1850 Byte Level Interface Circuit, is a member of the Intersil family of low-cost multiplexed wiring ICs. The integrated functions of the HIP7010 provide the system designer with components key to building a "Class B" multiplexed communications network interface, which fully conforms to the VPW Multiplexed Wiring protocol specified in the SAE J1850 Standard. The HIP7010 is designed to interface with a wide variety of Host microcontrollers via a standard three wire, high-speed (1MHz), synchronous, serial interface. The HIP7010 automatically produces properly framed VPW messages, **prepending** the Start of Frame (SOF) symbol and calculating and appending the CRC check byte. All circuitry needed to decode incoming messages, to validate CRC bytes, and to detect Breaks, End of Data (EOD), Idle bus, and illegal symbols is included. In-Frame Responses (IFRs) are fully supported for Type 1, Type 2, and Type 3 messages, with the appropriate Normalization Bit automatically generated. The HCMOS design allows proper operation at various input frequencies from 2MHz to 12MHz. Connection to the J1850 Bus is via a Intersil HIP7020.

### Ordering Information

PART NUMBER	TEMP. RANGE (°C)	PACKAGE	PKG. NO.
HIP7010P	-40 +125	14 Lead Plastic DIP	E14.3
HIP7010B	-40 +125	14 Lead Plastic SOIC (N)	M14.15

### Pinout

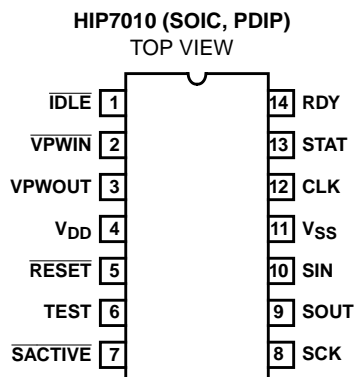

# HIP7010

## Block Diagram

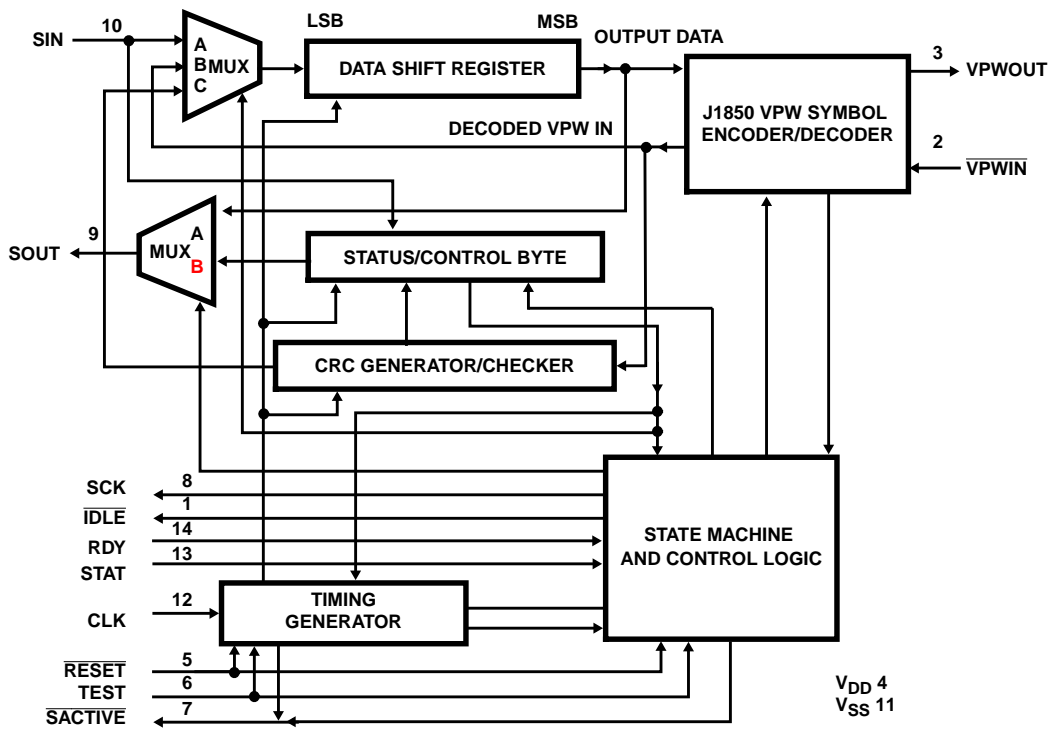

## Pin Description

PIN NUMBER	PIN NAME	IN/OUT	PIN DESCRIPTION
1	IDLE	OUT	CMOS Output
2	VPWIN	IN	CMOS Schmitt (No V <sub>DD</sub> Diode)
3	VPWOUT	OUT	CMOS Output
4	V <sub>DD</sub>	-	Power Supply
5	RESET	IN	CMOS Schmitt (No V <sub>DD</sub> Diode)
6	TEST	IN	CMOS Input with Pull-Down
7	SACTIVE	OUT	CMOS Output
8	SCK	OUT	Three-State with Pull-Down
9	SOUT	OUT	Three-State with Pull-Down
10	SIN	IN	CMOS Input with Pull-Down
11	V <sub>SS</sub>	-	Ground
12	CLK	IN	CMOS Schmitt (No V <sub>DD</sub> Diode)
13	STAT	IN	CMOS Input with Pull-Down
14	RDY	IN	CMOS Input with Pull-Down

# HIP7010

## Absolute Maximum Ratings

Supply Voltage ( $V_{DD}$ )	-0.3V to +7.0V
Input or Output Voltage	
Pins with $V_{DD}$ Diode	-0.3V to $V_{DD} + 0.3V$
Pins without $V_{DD}$ Diode	-0.3V to +10.0V
ESD Classification	Class 2
Gate Count	+2500 Gates

## Thermal Information

Thermal Resistance	$\theta_{JA}$
Plastic DIP Package	+100°C/W
SOIC Package	+120°C/W
Maximum Package Power Dissipation at +125°C	
DIP Package	250mW
SOIC Package	200mW
Operating Temperature Range ( $T_A$ )	-40°C to +125°C
Storage Temperature Range ( $T_{STG}$ )	-65°C to +150°C
Junction Temperature	+150°C
Lead Temperature (Soldering, 10s)	+265°C

CAUTION: Stresses above those listed in "Absolute Maximum Ratings" may cause permanent damage to the device. This is a stress only rating and operation of the device at these or any other conditions above those indicated in the operational sections of this specification is not implied.

## Operating Conditions

Operating Voltage Range	+3.0V to +5.5V	Input High Voltage	(0.8 $V_{DD}$ ) to $V_{DD}$
Operating Temperature Range	-40°C to +125°C	Input Rise and Fall Time	
Input Low Voltage	0V to +0.8V	CMOS Inputs	100ns Max
		CMOS Schmitt Inputs	Unlimited

## Electrical Specifications $T_A = -40^\circ\text{C}$ to $+125^\circ\text{C}$ , $V_{DD} = 5V_{DC} \pm 10\%$ , Unless Otherwise Specified

PARAMETERS	SYMBOL	CONDITIONS	MIN	TYP	MAX	UNITS
Supply Current						
Operating Current	$I_{OP}$	CLK = 2.0 MHz	-	1.0	5.0	mA
Power-Down Mode (Note 1)	$I_{PD}$	PD = 1	-	50	150	$\mu\text{A}$
Clock Stopped (Note 2)	$I_{STOP}$	CLK = $V_{SS}$ or $V_{DD}$	-	5.0	50	$\mu\text{A}$
Input High Voltage						
CMOS Level (SIN, STAT, RDY, TEST)	$V_{IH}$		0.7 $V_{DD}$	-	$V_{DD}$	V
Schmitt Trigger ( $\overline{\text{RESET}}$ , CLK, $\overline{\text{VPWIN}}$ )			0.8 $V_{DD}$	-	$V_{DD}$	V
Input Low Voltage						
CMOS Level (SIN, STAT, RDY, TEST)	$V_{IL}$		$V_{SS}$	-	0.3 $V_{DD}$	V
Schmitt Trigger ( $\overline{\text{RESET}}$ , CLK, $\overline{\text{VPWIN}}$ )			$V_{SS}$	-	0.2 $V_{DD}$	V
High Level Input Current						
(CLK, $\overline{\text{VPWIN}}$ , $\overline{\text{RESET}}$ )	$I_{IH}$	$V_{IN} = V_{DD}$	-1	0.001	1	$\mu\text{A}$
Input Buffer with Pull-Down (SIN, TEST, STAT, RDY)			100	200	500	$\mu\text{A}$
Low Level Input Current						
(CLK, $\overline{\text{VPWIN}}$ , $\overline{\text{RESET}}$ )	$I_{IL}$	$V_{IN} = V_{SS}$	-1	-0.001	1	$\mu\text{A}$
Input Buffer with Pull-Down (SIN, TEST, STAT, RDY)			-10	-0.01	10	$\mu\text{A}$
Output High Voltage						
(SCK, SOUT, $\overline{\text{VPWOUT}}$ , $\overline{\text{IDLE}}$ , $\overline{\text{SACTIVE}}$ )	$V_{OH}$	$I_{LOAD} = 0.8 \text{ mA}$	$V_{DD} - 0.8$	-	-	V
Output Low Voltage						
(SCK, SOUT, $\overline{\text{VPWOUT}}$ , $\overline{\text{IDLE}}$ , $\overline{\text{SACTIVE}}$ )	$V_{OL}$	$I_{LOAD} = -1.6 \text{ mA}$	-	-	0.4	V
High Impedance Leakage Current						
Three-State with Pull-Down (SCK, SOUT)	$I_{OZ}$	$V_{OUT} = V_{DD}$	100	200	500	$\mu\text{A}$
		$V_{OUT} = V_{SS}$	-10		10	$\mu\text{A}$
Schmitt Trigger Hysteresis Voltage ( $\overline{\text{RESET}}$ , CLK, $\overline{\text{VPWIN}}$ )	$V_{HYS}$		0.2	0.5	2.0	V

### NOTES:

- SIN, STAT, RDY, and TEST =  $V_{SS}$ ; **SACTIVE, SCK, and SOUT unconnected**;  $\overline{\text{VPWIN}} = V_{DD}$ ; CLK = 10MHz.
- SIN, STAT, RDY, and TEST =  $V_{SS}$ ; **SACTIVE, SCK, and SOUT unconnected**;  $\overline{\text{VPWIN}} = V_{DD}$ ; PD = 1.

# HIP7010

## Serial Interface Timing (See Figure 1- Figure 7) $T_A = -40^{\circ}\text{C}$ to $+125^{\circ}\text{C}$ , $V_{DD} = 5V_{DC} \pm 10\%$ , Unless Otherwise Specified

NUMBER	SYMBOL	PARAMETERS	MIN	TYP	MAX	UNITS
-	-	Operating Frequency	2	8	12	MHz
-	-	Input CLK Duty Cycle	40	50	60	%
(1)	$t_{CYC}$	SCK Cycle Time	-	1.0	-	MHz
(2)	$t_{LEAD}$	$\overline{\text{SACTIVE}}$ Lead Time Before Status/Control Transfer	450	750	850	ns
		Before Data Transfer	1150	1225	1300	ns
(3)	$t_{LAG}$	$\overline{\text{SACTIVE}}$ Lag Time After Status/Control Transfer	650	750	850	ns
		After Data Transfer	1250	1300	1400	ns
(4)	$t_{SCKH}$	Clock (SCK) HIGH Time	450	500	550	ns
(5)	$t_{SCKL}$	Clock (SCK) LOW Time	450	500	550	ns
(6)	$t_{DV\text{SCK}}$	Required Data In Setup Time (SIN to SCK)	-	10	50	ns
(7)	$t_{SCKDX}$	Required Data In Hold Time (SIN after SCK)	-	-10	40	ns
(8)	$t_{DZDA}$	Data Active from High Impedance Delay ( $\overline{\text{SACTIVE}}$ to SOUT Active)	-10	10	-	ns
(9)	$t_{DADZ}$	Data Active to High Impedance Delay ( $\overline{\text{SACTIVE}}$ to SOUT High Impedance)	-	10	40	ns
(10)	$t_{DV\text{SCK}}$	Data Out Setup Time (SOUT to SCK)	375	475	-	ns
(11)	$t_{DX\text{SCK}}$	Data Out Hold Time (SOUT after SCK)	375	475	-	ns
(12)	$t_{RISE}$	Output Rise Time ( $0.3V_{DD}$ to $0.7V_{DD}$ , $C_L = 100\text{pF}$ )	15	75	150	ns
(13)	$t_{FALL}$	Output Fall Time ( $0.7V_{DD}$ to $0.3V_{DD}$ , $C_L = 100\text{pF}$ )	7	25	75	ns
(14)	$t_{\text{STATH}}$	Required STAT Pulse Width	-	20	75	ns
(15)	$t_{RDYH}$	Required RDY Pulse Width	-	20	75	ns
	$t_{\text{RESETL}}$	Required $\overline{\text{RESET}}$ Pulse Width	-	20	75	ns
(16)	$t_{\text{SACTIVE}}$	$\overline{\text{SACTIVE}}$ Delay from RDY ( $\text{IDLE} = V_{SS}$ )	1150	1750	2450	ns
		$\overline{\text{SACTIVE}}$ Delay from STAT (FTU = 0)	5	285	900	ns
(17)	$t_{RDY\text{SCK}}$	Required RDY Removal Time Prior to Last SCK for Short RDY	-	25	100	ns
(18)	$t_{\text{SCKRDY}}$	Required RDY Hold Time after Last SCK for Long RDY	-	0	100	ns
(19)	$t_{\text{REC}}$	Required SERIAL Recovery Time (Minimum Time after $\overline{\text{SACTIVE}}$ Until Next RDY/STAT)	-	675	750	ns
	$f_{\text{SLOW}}$	Slow clock detect frequency limit	20	80	200	KHz

### NOTE:

1. All parameters are specifications of the HIP7010 component not of a system. Parameters specified as "Required" (i.e.,  $t_{\text{STATH}}$ ) refer to the requirements of the HIP7010. If a "Required" pulse width is specified as 75ns maximum, that implies that 75ns is the maximum width that any HIP7010 device will require. Therefore, a system that provides a **minimum** pulse width of 75ns will satisfy this **maximum** requirement.

# HIP7010

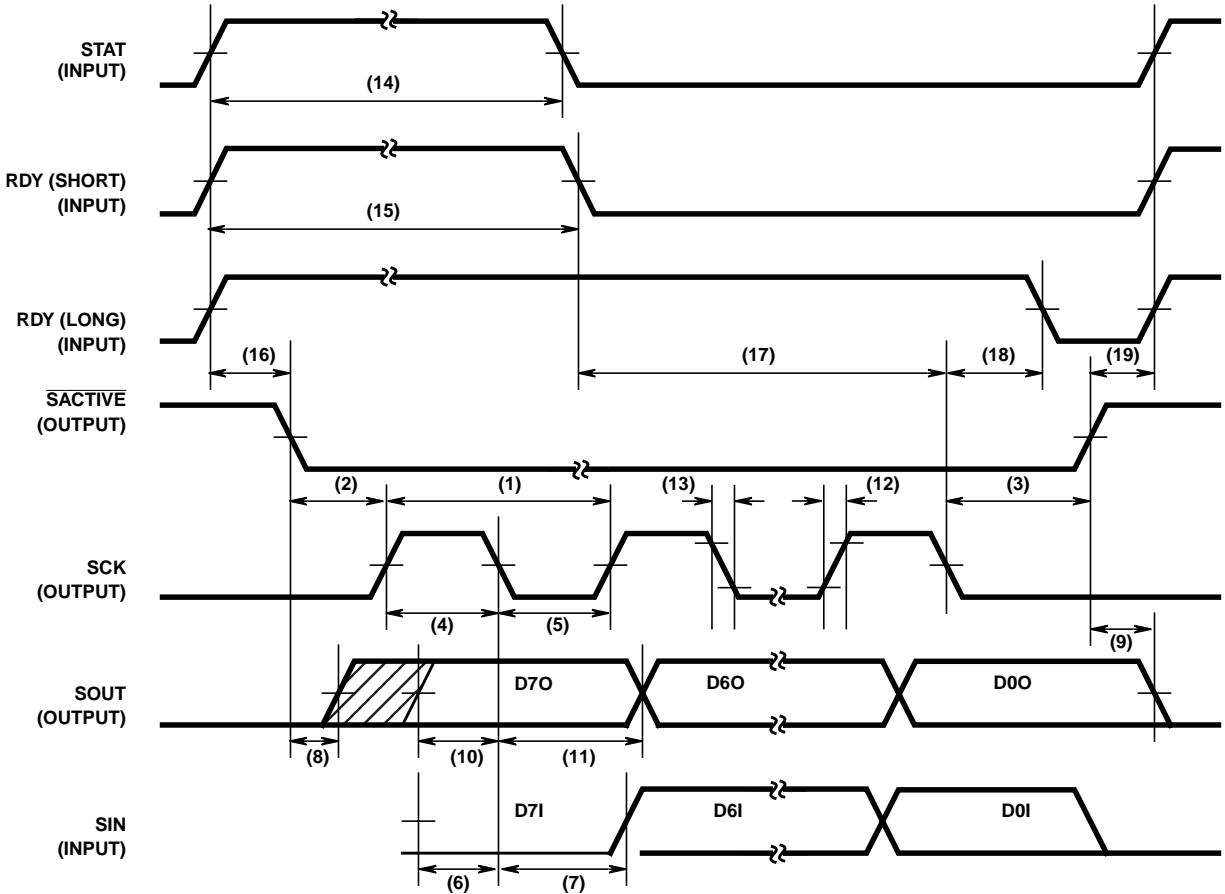

FIGURE 1. SERIAL INTERFACE TIMING DIAGRAM

NOTES:

1. Measurement points are from  $V_{DD}/2$ , except 12 and 13 which are measured between  $V_{IL}$  and  $V_{IH}$ .
2. All timings assume proper CLK frequency and Divide Select values to generate 1MHz SCK.

## Functional Pin Description

This section provides a description of each of the 14 pins of the HIP7010 as shown in Figure 2.

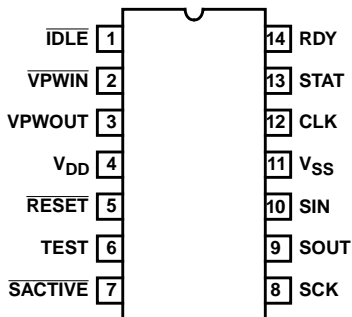

FIGURE 2. 14 PIN DIP AND SO TERMINAL ASSIGNMENTS

### $V_{DD}$ and $V_{SS}$ (Power)

Power is supplied to the HIP7010 using these two pins.  $V_{DD}$  is connected to the positive supply and  $V_{SS}$  is connected to the negative supply.

### CLK (Clock - Input)

The Clock input (CLK) provides the basic time base reference for all J1850 symbol detection and generation. Serial Bus transfers between the HIP7010 and the Host microcontroller are also timed based on the Clock input. Proper VPW symbol detection and generation requires a 2MHz clock which is internally derived from the CLK input. Various CLK input frequencies can be accommodated via the Divide Select bits in the Status/Control Register (see **Status/Control Register** for details).

An internal Slow Clock Detect circuit monitors the CLK input signal and generates a HIP7010 reset if the clock is inactive for more than  $1/f_{SLOW}$ . This is a safety mechanism to prevent blocking the J1850 and Serial busses in the event of a clock failure. The Slow Clock Detect reset can also be intentionally invoked by externally inhibiting CLK input transitions.

Power can be reduced under Host control via the PowerDown bit in the Status/Control Register (see Status/Control Register for details). Setting the Power-Down bit effectively stops internal clocking of the HIP7010.

## HIP7010

For enhanced noise immunity, the CLK input is a CMOS Schmitt trigger input. See **Electrical Specifications** for input levels.

### **VPWOUT (Variable Pulse Width Out - Output), VPWIN (Variable Pulse Width In - Input)**

These two lines are used to interface to a J1850 bus transceiver, such as the Intersil HIP7020. VPWOUT is the variable pulse width modulated output of the HIP7010's symbol encoder circuit.  $\overline{\text{VPWIN}}$  is the inverted input to the symbol decoder of the HIP7010.  $\overline{\text{VPWIN}}$  is a Schmitt input.

### **SIN (Serial In - Input), SOUT (Serial Out - Output), SCK (Serial Clock - Output), SACTIVE (Serial Bus Active - Output)**

These four lines constitute the synchronous Serial Interface (**SERIAL**) interface of the HIP7010. See the **Serial Interface (SERIAL) System** for details. SIN, SOUT, and SCK provide the three principal connections to the Host controller. SIN is a CMOS input. SOUT and SCK are three-state outputs which are only activated during serial transfers. The SIN, SOUT, and SCK pins contain integrated pull-down load devices which provide termination on the bus whenever it is in a high impedance state. The SACTIVE pin is a CMOS output, which pulls low when the HIP7010 is communicating on the serial bus. See **Serial Interface (SERIAL) System** and **Applications Information** for more details.

### **RDY (Byte Ready - Input)**

The Byte Ready (RDY) line is a "handshaking" input from the Host. Each rising edge on the RDY pin signifies that the Host has loaded a byte into its SERIAL transmit register and the HIP7010 can retrieve it (by generating clocks on SCK) when the HIP7010 is ready for the data. See **Serial Interface (SERIAL) System** and **Applications Information** for more details.

The RDY pin contains an integrated pull-down load device which will hold the pin low if it is left unconnected.

### **$\overline{\text{IDLE}}$ (Idle/Service Request - Output)**

The  $\overline{\text{IDLE}}$  output pin indicates that the J1850 Bus has been in a passive state for at least **275 $\mu\text{s}$**  and is now idle. If the bus has been passive for a minimum of 239 $\mu\text{s}$  and another node initiates a new message,  $\overline{\text{IDLE}}$  will pulse low for 1 $\mu\text{s}$ .

In its role as a Service Request pin, a reset forces  $\overline{\text{IDLE}}$  high. Following the reset,  $\overline{\text{IDLE}}$  remains high for 17 CLK cycles and is then driven low.  $\overline{\text{IDLE}}$  will remain low until 40 CLK cycles +1.5 $\mu\text{s}$  after completion of the first Status/Control byte transfer. The  $\overline{\text{IDLE}}$  pin will then resume its normal role, remaining high until a **275 $\mu\text{s}$**  lull (or 239 $\mu\text{s}$  plus a passive to active transition) has been detected on the J1850 bus. This provides a handshake mechanism to ensure the Host will reinitialize the HIP7010 each time the HIP7010 is reset via POR, RESET, or Slow Clock Detect.

If  $\overline{\text{IDLE}}$  is low when an echo failure causes the ERR bit to be set in the Status byte, the  $\overline{\text{IDLE}}$  pin will pulse high for 2 $\mu\text{s}$  and then return low (see Status/Control Register).

If  $\overline{\text{IDLE}}$  is low when the host sets the NXT bit in the control byte, the  $\overline{\text{IDLE}}$  pin will pulse high for 2 $\mu\text{s}$  and then return low (see Status/Control Register).

In general a Status/Control byte transfer should be performed each time IDLE goes low. See **Effects of Resets and Power-Down** and **Applications Information** for more details.

The  $\overline{\text{IDLE}}$  pin is an active low CMOS output. See **Operation of the HIP7010** for more details.

### **STAT (Request Status/Control - Input)**

The Request Status/Control (STAT) input pin is used by the Host microcontroller to initiate an exchange of the Host's control byte and the HIP7010's status byte. A low to high transition on the STAT input signals the HIP7010 that the Host has placed a control word in its SERIAL output register and is ready to exchange it with the HIP7010's status word. The HIP7010 controls the exchange by generating the 8 SCKs required. See **Serial Interface (SERIAL) System** and **Applications Information** for more details.

The STAT pin contains an integrated pull-down load device which will hold the pin low if it is left unconnected.

### **RESET (Reset - Input)**

The  $\overline{\text{RESET}}$  input is a low level active input, which resets the HIP7010. Resetting the HIP7010 forces SACTIVE high, disables the SOUT and SCK pins, forces the VPWOUT output low, drives  $\overline{\text{IDLE}}$  high, and returns the internal state machine to its initial state. Following reset, the HIP7010 is inhibited from transmitting or receiving J1850 messages until a Status/Control Register transfer has been completed (see **Effects Of Resets And Power-Down** for more details).

The HIP7010 is also reset during initial power-on, by an internal power-on-reset (POR) circuit.

Loss of a clock on the CLK input will cause a reset as described previously under **CLK**.

If not used, the  $\overline{\text{RESET}}$  pin should be tied to  $V_{\text{DD}}$ .

For enhanced noise immunity, the **RESET** input is a CMOS Schmitt trigger input. See **Electrical Specifications** for input levels.

### **TEST (Test Mode - Input)**

The TEST input provides a convenient method to test the HIP7010 at the component level. Raising the TEST pin to a high level causes the HIP7010 to enter a special TEST mode. In the TEST mode, a special portion of the state machine is activated which provides access to the Built-in-Test and diagnostic capabilities of the HIP7010 (see **Test Mode** for more details).

The TEST pin contains an integrated pull-down load device which will hold the pin low if it is left unconnected. In many applications the TEST pin will be left unconnected, to allow access via a board level ATE tester.

## J1850 VPW Messaging

This section provides an introduction to J1850 multiplexed communications. It is assumed that the user is or will become familiar with the appropriate documents published by the Society of Automotive Engineering (SAE). The following discussion is not comprehensive.

### Overview

The **SAE J1850 Standard** (Note 1) (J1850) establishes the requirements for communications on a Class B multiplexed wiring network for automotive applications. The J1850 document details the requirements in a three layer description which separately specifies the characteristics of the *physical layer*, the *data link layer*, and the *application layer*. There are several options within each layer which allows vehicle manufacturers to customize the network while still maintaining a level of universality.

#### NOTE:

1. **SAE J1850 Standard, Class B Data Communication Network Interface**, May 1994, Society of Automotive Engineers Inc.

The hardware of the Intersil HIP7010 provides features which facilitate implementation of the 10.4Kbps Variable Pulse Width Modulated (VPW) physical layer option of J1850. In combination with a bus transceiver, such as the Intersil J1850 Bus Transceiver HIP7020, and appropriate software algorithms, the HIP7010 circuitry enables the designer to completely implement a 10.4Kbps VPW Class B Communications Network Interface per J1850. Features of such an implementation include:

- Single Wire 10.4Kbps Communications
- Bit-by-Bit Bus Arbitration
- Industry Standard Protocol
- Message Acknowledgment (“In-Frame Response”) Capabilities
- Exceptionally Tolerant of Clock Skew, System Noise, and Ground Offsets
- Meets CARB and EPA Diagnostic Requirements
- Supports up to 32 Nodes
- Low Error Rates
- Excellent EMC Levels (when interfaced via Intersil J1850 Bus Transceiver HIP7020)

In addition to the standard J1850 features, the HIP7010 hardware provides a high speed mode, (intended for receive only use) which can significantly enhance vehicle maintenance capabilities. The high speed mode provides a 41.6Kbps communications path to any node built with the HIP7010.

### Anatomy of a J1850 VPW Message

All messages in a J1850 VPW system are sent along a single wire, shared bus. At any given moment the bus can be in either of two states: *active* (high) or *passive* (low). Multiple nodes are connected to the bus as a “wired-OR” network in which the bus is high if *any* (or more) node is generating an active output. The bus is only low when *no* nodes are generating active outputs. It follows that, when no communications are taking place the bus will rest in the passive state. A message begins when the bus is first driven to the high state. Each succeeding state transition (i.e., a change from active to passive or passive to active) transfers one bit of information (*symbol*) until the message is complete and the bus once again rests at the passive state. The interpretation of each symbol in the message is dependent on its duration (and state), hence, the descriptor Variable Pulse Width (VPW).

Each message has a beginning and an end, the span of which encompasses the entire *message* or *frame* (refer to Figure 3). A frame consists of an active *start of frame* (SOF) symbol and a passive *end of frame* (EOF) symbol sandwiched around a series of byte sized (8-bit) groups of symbols. The first byte of the frame contents is always a *header* byte, followed by possibly additional header bytes, followed by one or more *data* bytes, followed by an integrity check byte (*CRC* byte), followed by a passive *end of data* (EOD) symbol, followed by possibly one or more *in-frame-response* (IFR) bytes. To keep waiting times low, messages are limited to 12 bytes total (including header, data, check, and IFR bytes). All message bytes are transmitted most significant bit (MSB) first.

### VPW Symbol Definitions

Within the J1850 scheme, symbols are defined in terms of both duration and state (passive or active). The duration is measured as the time between successive transitions. There is one transition per symbol and one symbol per transition. The end of one symbol marks the beginning of the next. Since the bus is passive when a message begins and must return to that same state when the message completes, all frames have an even number of transitions and hence an even number of symbols.

There are unique definitions for data bit symbols (all the symbols which occur within the header, data, and check bytes) and protocol symbols (including SOF, EOD, and EOF). The duration of each symbol is expressed in terms of VPW Timing Pulses (TV values). Table 1 summarizes the TV definitions. Each TV is specified in terms of a *nominal* (or ideal) duration and a *minimum* and *maximum* duration. The span between the minimum and maximum limits accommodates system noise sources such as node to node clock skew, ground offsets, clock jitter, and electromechanical noise. There are no dead zones between the maximum of one TV and the minimum of the next.

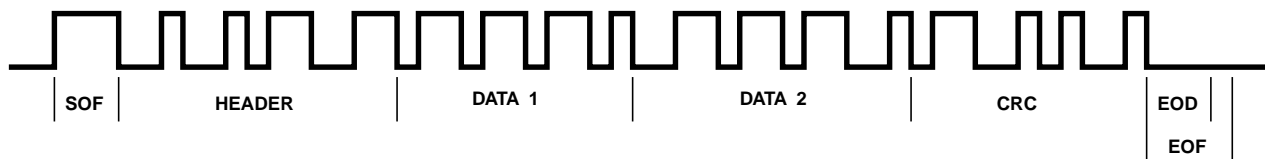

FIGURE 3. TYPICAL J1850 VPW MESSAGE FRAME

The terms *short* and *long* are often used to refer to pulses of duration TV1 and TV2 respectively.

TABLE 1. J1850 TV DEFINITIONS

TV ID	DURATION (ALL TIMES IN $\mu$ s)		
	MINIMUM	NOMINAL	MAXIMUM
Illegal	0	NA	$\leq 34$
TV1	$>34$	64	$\leq 96$
TV2	$>96$	128	$\leq 163$
TV3	$>163$	200	$\leq 239$
TV4	$>239$	280	NA
TV5	$>239$	300	NA
TV6	$>280$	300	NA

VPW is a non-return-to-zero (NRZ) protocol in which each transition represents a complete bit of information. Accordingly, a 0 data bit will sometimes be transmitted as a passive pulse and sometimes as an active pulse. Similarly, a 1 data bit will sometimes be transmitted as a passive pulse and sometimes as an active pulse. In order to accommodate arbitration (see **Bus Arbitration**) a *long active* pulse represents a 0 data bit and a *short active* pulse represents a 1 data bit. Complementing this fact, a *short passive* pulse represents a 0 and a *long passive* pulse represents a 1. Starting from a transition to the active state, a 0 data bit will maintain the active level longer than a 1. Similarly, starting from a transition to the passive state, a 0 data bit will return to the active level quicker than a 1. These facts give rise to the dominance of 0's over 1's on the J1850 bus as depicted in Figure 4. See **Bus Arbitration** for additional details.

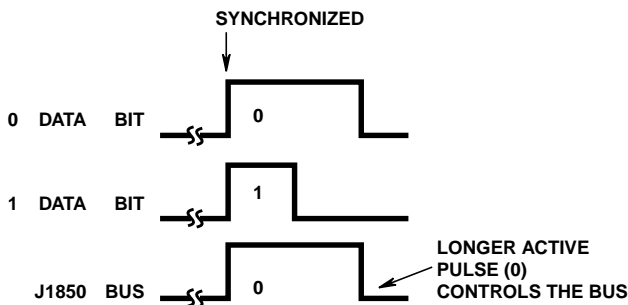

FIGURE 4A. DOMINANCE OF ACTIVE 0 DATA BIT

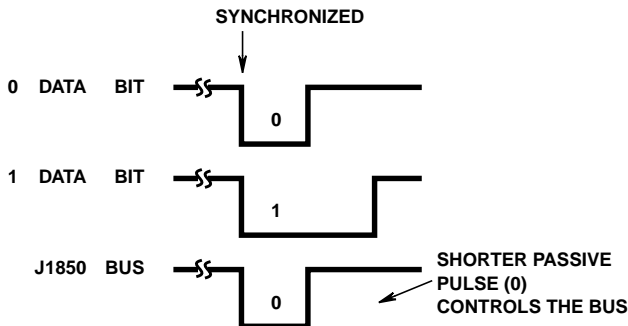

FIGURE 4B. DOMINANCE OF PASSIVE 0 DATA BIT  
FIGURE 4.

Table 2 summarizes the complete set of symbol definitions based on duration and state.

TABLE 2. J1850 SYMBOL DEFINITIONS

SYMBOL	DEFINITION
0 Data	Passive TV1 or Active TV2
1 Data	Active TV1 or Passive TV2
SOF (Start of Frame)	Active TV3
EOD (End of Data)	Passive TV3
EOF (End of Frame)	Passive TV4
IFS (Inter-Frame Separation)	Passive TV6
IDLE (Idle Bus)	Passive $>$ TV6 Nominal
NB (Normalization Bit)	Active TV1 or Active TV2
BRK (Break)	Active TV5

**In Frame Response (IFR)**

The distinction between two of the passive symbols, EOD and EOF, is subtle but important (refer to Figure 5). The EOD (TV3) interval signifies that the originator of the message is done broadcasting and any nodes which have been requested to respond (i.e., to acknowledge receipt of the message) can now do so. The EOD interval begins when the transmitting node has completed sending the eighth bit of the check byte. The transmitter simply releases the bus and allows it to revert to a passive state. In the course of normal messaging, no node can seize the bus until an EOD time has been detected. Once an EOD has elapsed, any nodes which are scheduled to produce an IFR will arbitrate for control of the bus (see **Bus Arbitration**) and respond appropriately. If no responses are forthcoming the bus remains in the passive state until an EOF (TV4) interval has elapsed. After the EOF has been generated, the frame is considered closed and the next communications on the bus will represent a totally new message.

IFRs can consist of multiple bytes from a single respondent, one byte from a single respondent, or one byte from multiple respondents. In all cases the first response byte must be preceded by a *normalization bit (NB)* which serves as a *start of response* symbol and places the bus in an active state so that following the IFR byte(s) the bus will be left in the passive state.

The NB symbol is by definition active, but can be either TV1 or TV2 in duration. The long variety (TV2) signifies the IFR contains a CRC byte. The short variety (TV1) precedes an IFR without CRC.

**Message Types**

Messages are classified into one of four *Types* according to whether the message has an IFR and what kind of IFR it is. The definitions are:

- Type 0 - No IFR
- Type 1 - One byte IFR from a single respondent (no CRC byte)
- Type 2 - One byte IFRs from multiple respondents (no CRC byte)
- Type 3 - Multiple byte IFR from a single respondent (CRC appended)

**Bus Arbitration**

The nature of multiplexed communications leads to contention issues when two or more nodes attempt to transmit on the bus simultaneously. Within J1850 VPW systems, messages are assigned varying levels of priority which allows implementation of an arbitration scheme to resolve potential contentions. The specified arbitration is performed on a symbol by symbol basis throughout the duration of every message.

Arbitration begins with the rising edge of the SOF pulse. No node should attempt to issue an SOF until an Idle bus has been detected (i.e., an *Inter-Frame Separation (IFS)* symbol with a period of TV6 has been received). If multiple nodes are ready to access the bus and are all waiting for an IFS to elapse, invariable skews in timing components will cause one arbitrary node to detect the Idle condition before all others and start transmission first. For this reason, all nodes waiting for an IFS will consider an IFS to have occurred if either:

1. An IFS nominal period has elapsed
- or
2. An EOF minimum period has elapsed *and* a rising edge has been detected

Arbitrating devices will all be synchronized during the SOF. Beginning with the first data bit and continuing to the EOF, every transmitting device is responsible for verifying that the symbol it sent was the symbol which appeared on the bus. Each transition, every transmitting node must decode the symbol, verify the received symbol matches the one sent, and begin timing of the next symbol. Since timing of the next symbol begins with the last transition detected on the bus, all transmitters are re-synchronized each symbol. When the received symbol doesn't match the symbol sent, a conflict (*bit collision*) occurs. Any device detecting a collision will assume it has lost arbitration and immediately relinquish the bus. Typically, after losing arbitration, a device will attempt retransmission of the message when the bus once again becomes idle.

The definition of 1 and 0 data bits (see Table 2 and discussion under **VPW Symbol Definitions**) leads to 0's having priority over 1's in this arbitration scheme. Header bytes are generally assigned such that arbitration is completed before the first data byte is transmitted. Because of the dominance of 0 bits and the MSB first bit order, a header with the hexadecimal value \$00 will have highest priority, then \$01, \$02, \$03, etc. An example of two nodes arbitrating for control of the bus is shown in Figure 6.

Arbitration also takes place during the IFR portion of a message, if more than one node is attempting to generate a response. Arbitration begins with the NB symbol, which follows the EOD and precedes the first IFR byte.

For Type 1 and Type 3 messages only, the respondent which successfully arbitrates for control of the bus produces an IFR. All other respondents abort their IFRs.

For Type 2 messages, all respondents which lose arbitration must re-attempt transmission at the end of each byte. Each node, which successfully responds, eliminates itself from the subsequent arbitration until all nodes have responded. This arbitration scheme limits each respondent to a single byte during a Type 2 IFR.

**Break**

To force a message to be aborted before EOF is reached, a break (BRK) symbol can be transmitted by any node. The BRK symbol is an active pulse of duration TV5. Reception of a break causes all nodes to reset to a *ready-to-receive* state and to re-arbitrate for control following an IFS.

**HIP7010 Architectural Overview**

The HIP7010 consists of three major functional blocks: the Serial Interface System (SERIAL) block; the State Machine (STATE) block; and the Symbol Encoder/Decoder (SENDEC) block. Transfers between the Host and the HIP7010 are controlled by the SERIAL block, while transfers between the J1850 bus and the HIP7010 are handled by the SENDEC

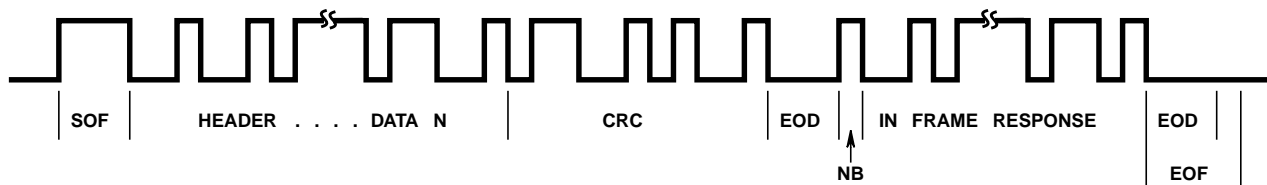

FIGURE 5. J1850 MESSAGE WITH IN-FRAME-RESPONSE

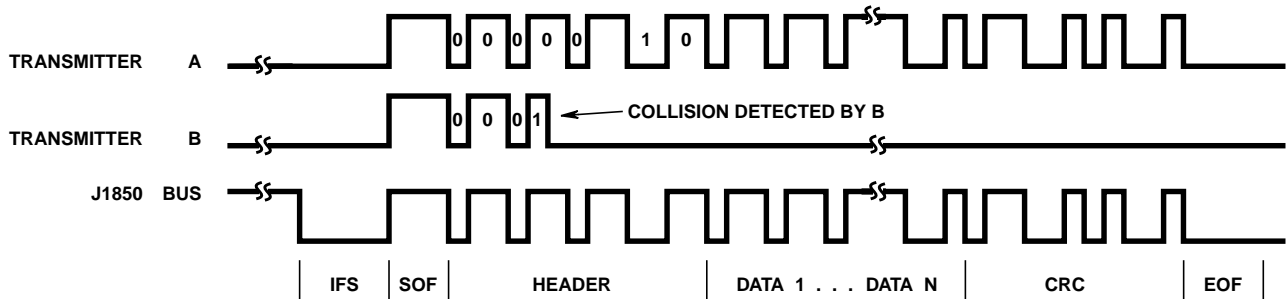

FIGURE 6. TWO NODES ARBITRATING FOR CONTROL OF J1850 BUS

block. The STATE block controls the flow of all data between the SERIAL and SENDEC blocks. The STATE block also controls Host/HIP7010 handshaking, automatic J1850 bus arbitration, break recognition, CRC checking, and many other features. In addition to the three major blocks the HIP7010 includes CRC generator/checker hardware, a Status/Control Register, and a Timing generator.

### Timing Generator

The timing generator, as its name suggests, generates all internal timing pulses required for the SERIAL, SENDEC, STATE, and CRC circuits. The CLK input pin is appropriately divided to produce an internal 2MHz clock which results in a 1MHz SERIAL transfer rate and VPW J1850 symbol timing with 1µs accuracy. The CLK pin of the HIP7010 can be driven with a variety of common microcontroller frequencies. Frequency selection is accomplished via three bits in the Status/Control register. See **Status/Control Register** for more details.

### The Serial Interface (SERIAL) System

#### Overview

The SERIAL system handles all interface between the Host microcontroller and the HIP7010. The SERIAL system is designed to interface directly with the Serial Peripheral Interface (SPI) systems of the Intersil CDP68HC05 family of microcontrollers. Identical interfaces are found on the 68HC11 and HC16 families. Compatible systems are found on most popular microcontrollers.

Serial data words are simultaneously transmitted and received over the SOUT/SIN lines, synchronized to the SCK clock stream. The word size is fixed at 8-bits. A series of eight clocks is required to transfer one word. With the exception of Status/Control Register transfers (described later), all SERIAL transfers use a single eight bit shift register within the HIP7010. The serial bits are "shifted out" on the SOUT pin, most significant bit (MSB) first, from the shift register. As each bit shifts out one end of the shift register, the data on the SIN input pin is, usually, shifted into the other end of the same shift register. After eight clocks, the original contents of the shift register have been entirely transmitted on the SOUT pin and replaced by the byte received on the SIN pin.

Most Host micros which include a synchronous serial interface, operate their interface in a manner compatible with the HIP7010s implementation. The result of each 8-bit SERIAL transfer is that the contents of the HIP7010s shift register and the Host's shift register have effectively been "swapped".

#### SERIAL Bus Timing

The SCK output of the HIP7010 is used to synchronize the movement of data both into and out of the device on its SIN and SOUT lines. As stated above, the Host and the HIP7010 are capable of exchanging a byte of information during a sequence of eight clocks generated on the SCK pin. The relationship between the clock signal on SCK and the data on SIN and SOUT is shown in Figure 7.

At least  $t_{LEAD}$  prior to each series of eight clocks, the SACTIVE output of the HIP7010 is driven low. SACTIVE remains low until a minimum of  $t_{LAG}$  after the last clock transition. When interfacing to a CDP68HC05 SPI compatible Host, the SACTIVE output would normally be connected to the SS input of the Host. The trailing edge of the SACTIVE signal can also be used as a flag to Hosts which don't automatically recognize the transfer of a serial byte.

The quiescent state of SCK is low. Once a transfer is initiated, the rising edge of each SCK pulse places the next bit on the SOUT line and the falling edge is used to latch the bit input on SIN.

The Host must adhere to this same timing, by meeting the input setup time requirements of SIN valid before the trailing edge of SCK (see **Electrical Specification** for details) and latching the SOUT data on the same edge. When interfacing the HIP7010 to a CDP68HC05 SPI compatible Host, the SPI interface should be programmed with CPHA = 1 and CPOL = 0.

At all times, other than during an actual SERIAL transfer between the HIP7010 and its Host, the SCK and SOUT pins are held in a high impedance state. This allows other devices connected to the Host via the SERIAL bus to be accessed when the HIP7010 is not transferring data. Utilization of the SERIAL bus by the HIP7010 is less than 5%, leaving significant bandwidth for other transfers. When held in the high impedance state, a pair of integrated pull-down devices on the SCK and SOUT pull the pins to ground, if they are not driven by another source. See **Applications Information** for a detailed discussion of SERIAL bus utilization.

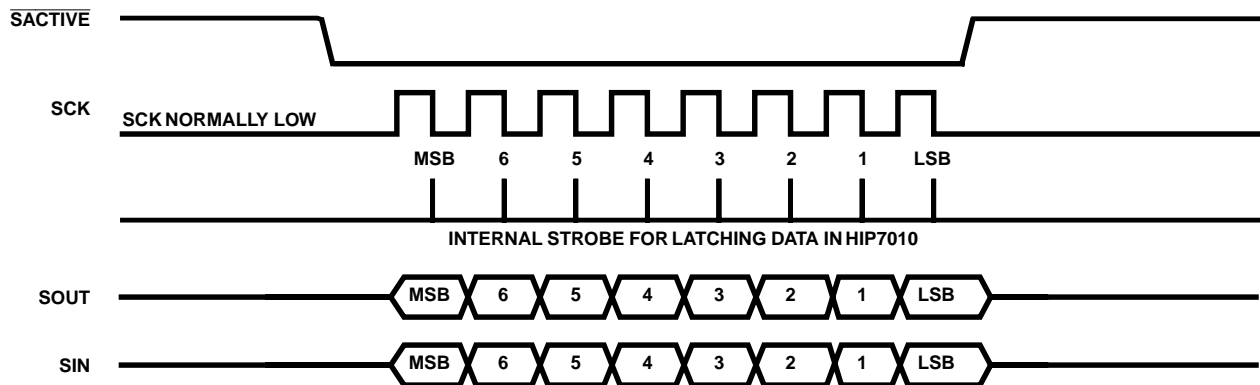

FIGURE 7. SERIAL BUS TIMING

## SERIAL Bus Transfers

The HIP7010 is always configured as a SERIAL “master”. As a master, the HIP7010 generates the transfer-synchronizing clock on the SCK pin, transmits data on the SOUT pin, and receives data on the SIN pin.

Whenever the HIP7010 receives a complete byte from the J1850 bus via the VPWIN line, it automatically initiates an *unsolicited* SERIAL transfer. The unsolicited transfer transmits the received (or reflected) byte to the Host and, if in the midst of transmitting a message, retrieves the next byte from the Host. While these unsolicited transfers are, strictly speaking, asynchronous to the Host’s activities, there are well defined rules which govern the minimum time between unsolicited transfers (i.e., no two unsolicited transfers can occur in less time than it takes to transfer one J1850 byte (8 x 64 = 512µs). See **Applications Information** for more details.

In addition to the unsolicited transfers which are based on receipt of incoming J1850 messages, the Host can initiate certain transfers in a more synchronous fashion. *Handshaking* between the Host and the HIP7010 is provided by the Byte Ready (RDY) and Request Status (STAT) pins. These two pins are driven by the Host and trigger the HIP7010 to initiate one of the two, *solicited* SERIAL transfers.

The Byte Ready (RDY) line is the first of two handshaking inputs from the Host. Each rising edge on the RDY pin signifies that the Host has loaded a byte into its serial transmit register and the HIP7010 can retrieve it. If the J1850 bus is available (i.e., IFS has elapsed) the rising edge of RDY is interpreted as signalling the first byte of a new message. The HIP7010 immediately performs a solicited SERIAL transfer to load the first byte. Prior to performing the transfer, the HIP7010 drives the J1850 bus high to initiate an SOF symbol. The SOF is then followed by the eight symbols which represent the transferred byte. If a J1850 message is already in progress, the rising edge of RDY is interpreted as signalling that the next byte of the message or of an IFR is ready to be transferred from the Host. The HIP7010 will initiate the transfer, as an unsolicited transfer, when conditions on the J1850 bus warrant the transfer (i.e., when the previously retrieved byte has been completely transmitted on the J1850 bus or after EOD for an IFR).

While the rising edge of RDY is used to notify the HIP7010 that the Host is ready to supply the next byte, the level of RDY following the actual serial transfer provides additional information. Figure 1 depicts the use of RDY. By driving the RDY line high and returning it low before the transfer has been completed, the HIP7010 will detect a low. This is referred to as a *short RDY*. If the RDY line is brought high and held high until the transfer is complete, a high level is detected by the HIP7010. This is referred to as a *long RDY*.

A short RDY signals a normal transfer, but a long RDY has special significance. A long RDY indicates that the byte currently sitting within the Host is the last byte of a message or of an IFR. When transmitting the body of a message or a Type 3 IFR the HIP7010 will automatically append the CRC after the byte for which the long RDY was used. When responding with a Type 1 or Type 2 IFR the response is a single byte, and as

such it is always the last byte. For sake of consistency the HIP7010 requires a long RDY for Type 1 and Type 2 IFRs. See **Status/Control Register** and **Application Information** for more details.

The other handshaking input is the Request Status/Control (STAT) input pin. STAT is used by the Host microcontroller to initiate an exchange of the Host’s *control byte* and the HIP7010’s *status byte*. A low to high transition on the STAT input signals the HIP7010 that the Host has placed a control word in it’s serial output register and is ready to exchange it with the HIP7010’s status word. The HIP7010 will generate the eight SCKs for the solicited transfer as soon as feasible. To avoid confusion with the transfer of a received J1850 byte, STAT should generally be pulsed shortly after receiving each data byte from the HIP7010. This technique is safe, because once a J1850 message byte has been received from or sent to the HIP7010, another unsolicited transfer is guaranteed not to happen for at least 500µs. A Control/Status byte transfer should also be performed in response to each high to low transition on the IDLE line. See **Application Information** for more details.

## Status/Control Register

The Status/Control Register is actually a pair of registers: the Status Register and the Control Register. When the Host initiates a Status/Control Register transfer by raising the STAT input, the HIP7010 sends the contents of the Status Register to the Host and simultaneously loads the Control register with the byte received from the Host.

### Status Register

The Status Register contains eight, read-only, status bits.

7	6	5	4	3	2	1	0
EOD	MACK	0	FTU	4X	CRC	ERR	BRK

**B7, EOD** When an EOD symbol has been received on VPWIN and an IFR byte is received from the J1850 bus, the End-of-Data flag (EOD) is set, during the unsolicited transfer of the byte from the HIP7010 to the Host. EOD remains set, until the unsolicited transfer of the first byte of the next frame.

EOD can be used to distinguish the IFR portion of a frame from the message portion.

EOD is cleared by reset.

**B6, MACK** If MACK (Multi-byte ACKnowledge) is high, either the MACK control bit has been set during a previous Status/Control Register transfer or a long normalization bit has been received following an EOD. When both MACK is set and the EOD flag (see B7, EOD) is set, the most recent data byte transferred is part of a Type 3 IFR.

The value of MACK is only relevant if EOD = 1. MACK remains set until the unsolicited transfer of the first byte of the next frame.

MACK is cleared by reset.

## HIP7010

- B5, 0** Bit 5 of the Status byte is not used and will always read as a 0.
- B4, FTU** When First Time Up (FTU) is high, it indicates that a reset has occurred since the last Status/Control Register transfer. FTU is high during the first Status/Control Register transfer after a reset and low thereafter.
- FTU can be used to recognize that a Slow Clock Detect reset has occurred or to ensure that a Status/Control Register transfer has been successfully completed since the last reset.
- B3, 4X** The 4X status flag indicates that the 4X mode bit has been set in the Control Register. This bit reflects the contents of the Control Register not the current mode of the HIP7010's SENDEC. The SENDEC only changes modes synchronously with an edge detected on the  $\overline{VPWIN}$  pin. See description of the 4X control bit for details. 4X is cleared by reset and the trailing edge of a break.
- B2, CRC** The CRC Error flag (CRC) is set when a CRC error has been detected in the current frame.
- CRC is cleared by reset and at the conclusion of the Status/Control Register transfer.
- B1, ERR** The Error flag (ERR) is set when an illegal symbol or other, non-CRC error has been detected on the VPWIN pin. Following are some of the many errors which will cause ERR to be set: 1. An illegal symbol, (i.e., a symbol other than a TV1, TV2, or Break in the middle of a data byte); 2. Receipt of a truncated byte (i.e., less than 8 symbols); 3. The Host attempting to initiate a message more than 96 $\mu$ s after the IDLE line goes high; 4. An improperly framed message (i.e., SOF not equal to TV3, wrong EOD, EOF, or NB widths); 5. Failure by the Host to use the long form of RDY to indicate the last byte of a message; 6. An attempt by the Host to transmit a single byte (Type 1 or Type 2) IFR by setting ACK but without using the long form of RDY for the byte transfer; 7. Setting the Host asserting STAT during a data byte transfer; 8. A transition has occurred on the VPWOUT pin and the reflected transition has not been detected on  $\overline{VPWIN}$  (echo fail).
- ERR is cleared by a reset and at the conclusion of the Status/Control Register transfer.
- B0, BRK** The break flag (BRK) is set on the first rising edge of  $\overline{VPWIN}$  after a BRK symbol has been detected on the J1850 bus. If the Host was transmitting or has a message to transmit, it should re-arbitrate for the bus following an IFS ( $\overline{IDLE}$  goes low).
- BRK automatically clears the 4X mode of the SENDEC and resets the 4X bit in the Status byte.
- BRK is cleared by a reset or at the conclusion of the Status/Control Register transfer.

### Control Register

The Control Register contains eight, write-only, control bits. The PD, NXT, MACK, and ACK bits can only be set high; they are cleared by hardware under specific conditions. The other four bits can be both set and reset by the Host. All bits in the Control Register are cleared by reset.

<b>7</b>	<b>6</b>	<b>5</b>	<b>4</b>	<b>3</b>	<b>2</b>	<b>1</b>	<b>0</b>
ACK	MACK	NXT	PD	4X	DS2	DS1	DS0

**B7, ACK** Setting the Acknowledgment (ACK) bit signals the HIP7010 that, following the EOD, an IFR response is to be sent. Once set, the ACK bit cannot be cleared by the Host. ACK is cleared upon successful transmission of the IFR or at the next Idle.

The ACK bit can be set anytime prior to 135 $\mu$ s after the final byte (the CRC) of a message. The first IFR byte must be loaded into the Host's serial output register, and the RDY line set **after** the HIP7010 transfers the next-to-last byte to the Host, and **before** the HIP7010 transfers the last byte (CRC) of the J1850 message to the Host. When the CRC byte is sent to the Host from the HIP7010, the IFR byte will be simultaneously loaded into the HIP7010.

To send a single byte (Type 1 or Type 2) IFR the Host must leave MACK (B6 of the Control Register) low and use the long RDY line format.

When sending a single byte (Type 1 or Type 2) IFR, the possibility of losing arbitration exists. In the case of a Type 1 IFR no further action should be taken. The standard protocol for handling loss of arbitration during a Type 2 IFR is to re-attempt the transmission until successful. To ensure proper transmission of the IFR the Host must repeatedly load its serial output register with the desired IFR byte, and set RDY (using the short format), until the IFR has been properly received back. There is no danger of inadvertently sending the IFR byte twice. The HIP7010 monitors the arbitration results and will transmit the IFR byte only once. The ACK bit is automatically cleared upon the first successful transmission, thus preventing a second transmission. The Host controls when the ACK bit is set. During normal operation the Host must only set ACK once per IFR.

To send a Type 3 IFR the Host must set MACK high and use the short format of the RDY for all bytes except the last, when the long format is used. A CRC will automatically be appended to the last byte of a Type 3 IFR. A Type 3 IFR, consisting of a single byte plus CRC, can be created by setting MACK high and using the long RDY line format for loading the single data byte.

When sending a Type 3 IFR, the possibility of losing arbitration during the IFR also exists. In the case of Type 3 IFRs, once arbitration has been

lost the Host no longer needs to continue transmitting bytes. As in the case of Type 2 IFRs, the Host cannot know arbitration has been lost until after the next byte to transmit has been loaded. Again, there is no danger of sending extra bytes because the HIP7010 automatically suspends transmissions once arbitration is lost.

**B6, MACK** The Multi-byte Acknowledge (MACK) bit, in conjunction with the ACK bit, signals the HIP7010 that, following the EOD, a Type 3 IFR with CRC response is to be sent. Once set, the MACK bit cannot be cleared by the Host. MACK is cleared upon detection of an Idle following the transmission of the IFR. Setting MACK without also setting ACK will result in no IFR being transmitted.

The MACK bit can be set anytime prior to 135µs after the final byte (the CRC) of a message. The first IFR byte must be loaded into the Host's serial output register, and the RDY line set **after** the HIP7010 transfers the next-to-last byte to the Host, and **before** the HIP7010 transfers the last byte (CRC) of the J1850 message to the Host. When the CRC byte is sent to the Host from the HIP7010, the first IFR byte will be simultaneously loaded into the HIP7010. To send a Type 3 IFR the Host uses the short format of the RDY for all bytes except the last, when the long format is used.

Setting the MACK bit in the Control Register is not immediately reflected in the MACK bit of the Status Register. The status bit is updated following each data transfer.

**B5, NXT** If the Wait for Next Idle (NXT) bit is asserted high during a Status/Control Register transfer, the HIP7010 State Machine is re-initialized to a "wait for Idle" state. The VPWOUT pin is driven low and the IDLE pin is reset high. Activity on the VPWIN pin is ignored until a valid Idle is detected. When NXT is asserted the IDLE pin will go high for a minimum of 6µs. If the bus is Idle at the end of the 6µs period, IDLE will be driven low and the HIP7010 will be ready to transmit or receive a J1850 message. If the bus is not Idle, current activity on the VPWIN pin is ignored until a new Idle is detected.

The NXT bit enables the Host to ignore the balance of the current message. Unsolicited transfers from the HIP7010 are guaranteed not to occur until the next Idle occurs. Transfers resume following the first byte of the next message.

**B4, PD** The Power-Down (PD) bit is used to halt internal clocks to the HIP7010 to minimize power. A low level on the VPWIN, a low to high edge on the STAT pin, or a high level on the RDY pin will clear the PD bit and normal HIP7010 functions will resume.

PD can only be set if the IDLE pin is low or during the first Status/Control Register transfer following a reset. The CLK input is internally gated off at the end of the Status/Control Register transfer.

There are two situations which can cause the PD bit to be cleared prematurely: 1. The RDY input is high during the Status/Control Register transfer (since this is under control of the Host it should be avoided); 2. A noise pulse of less than 7µs duration occurs on the VPWIN line.

If either of these situations occur, the PD will be cleared, the HIP7010 will resume operating and look for a valid edge on VPWIN, RDY, or STAT. If no valid edge has occurred the HIP7010 will recycle to the top of the State Machine, pulsing IDLE high for a minimum of 2µs. It is the responsibility of the Host to monitor the IDLE pin after setting PD to ensure that the POWER-DOWN mode has been successfully entered.

See **Effects of Resets and Power-Down** for a detailed discussion of the Power-Down mode.

**B3, 4X** Setting the High Speed Mode (4X) bit causes the HIP7010's SENDEC to decode symbols received on the J1850 bus at 0.25X the normal durations. The 4X mode is designed to allowed receipt of messages at 4X the normal J1850 rate. It is intended for manufacturing and diagnostic use, not normal "down the road" vehicle communications. Transmission is inhibited while the 4X bit is set.

The 4X bit can only be written to when the IDLE pin is low or during the first Status/Control transfer following a reset. Setting 4X is inhibited during the first Status/Control after a Break. The SENDEC begins operating at the 4X rate upon receipt of the next edge. The system must provide sufficient time for all nodes to detect the Idle, interpret the "shift to high speed" message, and change their mode bits before issuing a high speed SOF.

4X is cleared by receipt of a Break symbol on the J1850 bus and it can also be cleared by performing a Status/Control Register transfer with the 4X bit low. When cleared via a Status/Control Register transfer, IDLE must be low. The SENDEC reverts to operating at the normal rate upon receipt of the next edge.

4X mode cannot be utilized for transmitting messages. VPWOUT is disabled in hardware, but the State Machine will attempt to transmit if RDY is strobed. It is the Host's responsibility to refrain from transmitting in 4X mode.

**B2, DS2, B1, DSI, B0, DSI**

The three Divide Select bits (DS2-DS0) are used to match the internal clock divider with the input frequency on the CLK input to produce the required 2MHz internal time base. Table 3 shows the clock divide values and nominal input frequency for the eight combinations of DS2-DS0.

During a HIP7010 reset caused by a POR, a Slow Clock Detect, or a low on the RESET line, the Clock Divider is inhibited and a fixed divide-by sixteen clock divider is activated. This is greater than any selectable divide-by and guarantees proper operation of the SERIAL interface for all valid operating frequencies (although the transfer rate will be below 1MHz). The CLK divide-by remains at sixteen and operation of the HIP7010 is suspended until the Host performs a Status/Control Register transfer to set the proper divide value. The State Machine and SENDEC are held in a reset state (passive) until the first Status/Control Register transfer has been completed. This ensures proper setting of the divide selects prior to generation or receipt of any symbols.

**TABLE 3. DS2-DS0 CLOCK DIVIDER SELECTIONS**

DS2	DS1	DS0	CLK INPUT FREQ. (MHZ)	INTERNAL HIP7010 CLK DIVIDE-BY
0	0	0	24 (Note 1)	12
0	0	1	12	6
0	1	0	20 (Note 1)	10
0	1	1	10	5
1	0	0	16 (Note 1)	8
1	0	1	8	4
1	1	0	4	2
1	1	1	2	1

NOTE:

1. Invalid operating frequency.

Once DS2-DS0 have been set following a reset, they must not be altered. Each Status/Control Register transfer must properly reassert the same DS2-DS0 values to maintain proper clocking. Selecting a DS2-DS0 combination which is too low for the given CLK frequency can result in loss of SERIAL communications, due to excessive clocking rates. In such instances the only recovery mechanism is to force a HIP7010 reset by pulling the RESET input low, interrupting the CLK input, or performing a power-on reset. A well behaved Host will avoid changes to DS2-DS0. System fault tolerance can be maximized by using the lowest possible frequency at the CLK input.

Power-down does **not** reset DS2-DS0, allowing rapid "wake-up" from the Power-down state.

## Symbol Encoder/Decoder (SENDEC) Operation

The Symbol Encoder/Decoder (SENDEC) hardware integrated in the HIP7010 handles generation and reception of J1850 messages on a symbol by symbol basis. Symbols are output from the SENDEC, as a digital signal, on the VPWOUT

pin and input, as a digital signal, on the  $\overline{VPWIN}$  pin. These two lines must be connected through a bus transceiver (such as the Intersil J1850 Bus Transceiver HIP7020) to the single wire J1850 bus. The transceiver is responsible for generating and receiving waveforms consistent with the physical layer specifications of J1850. In addition, the transceiver is responsible for providing isolation from bus transients.

Every symbol sent out on the VPWOUT is, in effect, inverted and *reflected* back on the  $\overline{VPWIN}$  pin after some finite delay through the transceiver. In actuality, only active symbols are guaranteed to be reflected unchanged. If the transmitted symbol is passive and another node is simultaneously sending an active symbol, the active symbol will dominate and pull the bus to a high level. The SENDEC circuitry includes a 3-bit digital filter which effectively filters out noise pulses less than 7 $\mu$ s in duration.

The STATE logic transfers data bits between the SERIAL system and the SENDEC, and handles addition of required frame elements such as the SOF symbol and the CRC byte. When transmitting bytes, bits are taken from the SERIAL shift register and translated into the required symbols, bit by bit. **Timing of each symbol is calculated from the last transition on the  $\overline{VPWIN}$  line** which keeps all nodes on the J1850 bus "in synch" during arbitration periods.

Decoding of received symbols is automatically performed by the SENDEC. The decoded symbol is translated to a 0 or 1 value and transferred by the STATE logic into the SERIAL shift register. As each symbol is decoded, it is shifted into the SERIAL shift register and, if transmitting, the next bit to transmit on the J1850 bus is shifted out. Once an entire byte has been loaded into the SERIAL shift register the STATE logic automatically generates an unsolicited transfer of the byte to the Host.

Whenever the SENDEC is transmitting, it is simultaneously monitoring the "reflected" symbol on the  $\overline{VPWIN}$  line. At each transition the reflected symbol is read and compared to the sent one. If the reflected symbol doesn't match the symbol sent, a collision has occurred and the HIP7010 automatically disables transmissions until the next Idle/IFR period. If there was no collision, the HIP7010 continues transmitting until the entire byte has been sent. Once the byte has been sent, a full byte will also have been reflected and received by the HIP7010. As discussed above, the HIP7010 initiates a transfer of the received byte to the Host, which allows the Host the opportunity to compare the sent and reflected bytes, and to transfer the next byte of the message.

In addition to features already discussed, the SENDEC includes, noise detection, Idle bus detection, a wake-up facility, "no echo" detection, and a high speed receive mode. Symbol timing is based on the main CLK input. The programmable prescaler, controlled by the DS0-DS2 bits in the Control Register, allows proper SENDEC operation with a variety of CLK input frequencies (see **DS2-DS0** under **Status/Control Register** for prescaler details). The high speed mode is a J1850 extension which allows production and/or maintenance equipment to transmit messages at 4X the normal 10.4Kbps rate (see **4X** under **Status/Control Register** for prescaler details).

Software algorithms can be implemented in the Host to provide message buffering and filtering and other needed fea-

tures to create a complete J1850 VPW node. See the **Applications Information** section for typical algorithms.

### The State Machine Logic (STATE)

The State Machine Logic (STATE) of the HIP7010, is a sequential state machine implementation of the J1850 VPW data link layer. STATE controls data flows within the HIP7010 and between the Host and the J1850 bus.

When receiving messages, STATE monitors the input from the SENDEC, building byte sized chunks to send to the Host. As each byte is assembled, STATE transfers the result to the Host via the Serial interface, as an unsolicited transfer. Upon receipt of a complete message (recognized by EOD), STATE verifies both the CRC and bit counts and sets appropriate Status Register flags.

When transmitting messages from the Host to the J1850 bus, STATE waits for the first RDY input transition, after which it retrieves the first byte from the Host and initiates the message with an SOF. Each bit of the Host's message byte is transferred to the J1850 bus via the SENDEC. When the transfer of a byte is complete, STATE checks for a new RDY (if there is one), retrieves the associated byte, and again transfers the byte via the SENDEC to the J1850 bus. After retrieving each byte from the Host, STATE checks to see if the long RDY format was used, which indicates this is the end of the Host's message. If the message is complete, STATE transfers the final byte to the J1850 Bus and then, automatically, sends the computed CRC to the J1850 bus.

Throughout the transmission of a message from the Host to the J1850 bus, STATE monitors the symbols reflected back via the SENDEC and handles all bus conditions such as loss of arbitration, illegal bits, Break, bad CRC, and missing bits. STATE also catches Host errors including failure to set the RDY line in time for the next byte transfer, attempting to initiate a new message more than 96 $\mu$ s after  $\overline{\text{IDLE}}$  has gone away, and inappropriate use of the STAT line (i.e., requesting a Status/Control Register transfer during an unsolicited transfer of the reflected data).

In 4X mode VPWOUT is disabled in hardware, but STATE will attempt to transmit if RDY is strobed. This results in STATE clearing  $\overline{\text{IDLE}}$  and waiting for the leading edge of SOF. Since VPWOUT is blocked STATE will only recover if another node's SOF is received or NXT is set. It is the Host's responsibility to refrain from transmitting in 4X mode.

The Control Register bits influence STATE. If ACK is set, STATE handles sequencing of the requested IFR. The flow consists of waiting for an EOD, sending the appropriate Normalization Bit (Type 1/2 vs Type 3 IFR), transferring the IFR byte(s) from the Host to the J1850 bus, handling arbitration, and finally adding the CRC to Type 3 IFRs. As with normal transmissions, STATE contains error handling to react appropriately to all J1850 bus conditions.

Detection of an Idle on the bus causes STATE to set the  $\overline{\text{IDLE}}$  pin. STATE clears the  $\overline{\text{IDLE}}$  pin upon receipt of a transition on the  $\overline{\text{VPWIN}}$  line or when the Host initiates a new message.

Detection of a Break on the J1850 bus causes an interrupt input to STATE which causes the HIP7010 to cease any current transmission and enter a *wait for  $\overline{\text{IDLE}}$*  mode.

### Effects of Resets and Power-Down

#### Resets

A Power-On reset, a Slow Clock Detect reset, and a low on the  $\overline{\text{RESET}}$  pin all have an identical effect on the operation of the HIP7010. All resets are asynchronous and *immediately* do the following:

- VPWOUT is forced low.
- The HIP7010 is set to *RESTART mode*.
- The internal divide-by is set to sixteen and held at that value until the RESTART mode ends.
- $\overline{\text{ACTIVE}}$  is forced high and SCK and SOUT are set to a high impedance state.
- The ACK, MACK, NXT, PD, and 4X bits are cleared in the Control Register.
- All Status Register bits are cleared (except bit 4, FTU, which is set to a 1).
- $\overline{\text{IDLE}}$  is forced high and held high for 17 CLKs after the source of the reset is removed. After 17 CLKs,  $\overline{\text{IDLE}}$  is forced low.  $\overline{\text{IDLE}}$  Remains low until 40 CLKs + 1.5 $\mu$ s after the first Status/Control Register transfer.
- The SENDEC is reset, holding the symbol timer at a count of 0 and clearing the 3-bit  $\overline{\text{VPWIN}}$  filter to all 0's, until the RESTART mode ends.
- STATE is held in a *reset loop* until the RESTART mode ends. While STATE is in the reset loop, transitions on the RDY pin are ignored.

The RESTART mode is entered by any reset and ends when the first Status/Control Register transfer has been completed. Upon exiting the RESTART mode the HIP7010 enters its normal *RUN mode*. This is reflected in the clearing of the FTU bit of the Status Register.

When the RESTART mode ends and the RUN mode begins, the internal divide-by is set to the value programmed via DS2-DS0 in the Control Register. The  $\overline{\text{IDLE}}$  pin is driven high after 40 CLKs, the SENDECs counter and  $\overline{\text{VPWIN}}$  filter begin operating, and STATE begins monitoring the outputs of SENDEC looking for an Idle.

The HIP7010 remains in RUN mode until another reset occurs or the POWER-DOWN mode is entered.

#### Power-Down

The *POWER-DOWN mode* of the HIP7010 is entered by setting the PD bit in the Control Register (see **Control Register** for more information). Setting the PD bit can only be done when the HIP7010 is driving the IDLE pin low. Once set, the PD forces the HIP7010 to the POWER-DOWN mode 2 $\mu$ s after the completion of the Status/Control Register transfer. While in the POWER-DOWN mode the CLK input is internally gated off, minimizing power dissipation. The Slow Clock Detect is inhibited while in the POWER-DOWN mode.

A return to the RUN mode from the POWER-DOWN mode is normally caused by a low level on VPWIN. During POWER-

DOWN the input signal is not filtered via the  $7\mu\text{s}$  digital filter (no clocks are available to drive the digital filter). Without filtering in place it is possible for a noise spike, less than  $7\mu\text{s}$  wide, to wake-up the HIP7010. In such a case the HIP7010 returns to RUN mode, but the spike is rejected by the now running, digital filter and the bus continues in the Idle state. To notify the Host when such spurious wake-ups occur, STATE monitors the output of the digital filter and if, within  $12\mu\text{s}$  after the wake-up, the digital filter doesn't indicate VPWIN is low, STATE pulses IDLE high for  $2\mu\text{s}$  and then drives it low again. The HIP7010 is now in the RUN mode. It is the responsibility of the Host to recognize the pulse on the IDLE pin and set PD in the Control Register to reenter the POWER-DOWN mode. In systems where the Host directly monitors the VPWIN pin during POWER-DOWN, monitoring the IDLE pin may not be necessary.

One of the mechanisms to exit POWER-DOWN is to provide a high level on the RDY pin. Since this is a level sensitive event the HOST must ensure that RDY is not already high when the PD bit is set in the Control Register. A well behaved Host will control this properly. However, in the event RDY is high when PD is set, a  $12\mu\text{s}$  time-out will occur similar to that described for waking-up with a noise pulse on  $\overline{\text{VPWIN}}$ . After the time-out, IDLE will pulse high for  $2\mu\text{s}$  then low again. The Host should react to this pulse appropriately.

## Test Mode

### Overview

When the TEST Pin of the HIP7010 is driven high, it modifies the operation of the BLIC in two ways:

1. It inhibits receipt of bus signals on the  $\overline{\text{VPWIN}}$  pin and internally routes the VPWOUT signal to the VPWIN input. During this "loopback" mode of operation the VPWOUT pin will continue to operate.
2. The State Machine which controls the operation of the HIP7010 is extended to include a special TEST Sequence. The TEST Sequence can only be entered from one location in the normal State Machine flow. This point can conveniently be reached following reset of the BLIC or by setting the NXT bit in the BLIC's Control Register.

### Entering the TEST Sequence

Entry into the TEST Sequence of the BLIC's State Machine requires that the TEST pin is high **and** the State Machine is at it's "start". The State Machine will always pass through its starting point at certain identifiable times:

1. Following the first Status/Control Transfer after a Reset
2. Following completion of a J1850 message (i.e., after EOD)
3. Following abortion of a message frame due to noise, bad symbol, bad CRC, receipt of a Break, etc.
4. Following setting of the NXT bit in the Control Register

As are all states, the starting point is a transitory state. Once entered, the State Machine will remain at its start only until the bus has been low for a TV4 min (i.e., EOF,  $239\mu\text{s}$ ). To ensure proper synchronization, the TEST Sequence should generally be entered only after a Reset or after setting the NXT bit in the BLIC's Control Register.

### Test Block 1

Once the TEST Sequence has been entered,  $\overline{\text{IDLE}}$  will go low. Once  $\overline{\text{IDLE}}$  has gone low, each time that RDY is pulsed (with the **short** form of RDY) it will result in an exchange of data between the Host's SPI register and the BLIC's data register. Following a reset, the BLIC's data register will contain \$00. For all other exchanges during the TEST sequence the BLIC will give back to the Host the byte it supplied during the prior exchange. During each exchange the  $\overline{\text{IDLE}}$  pin will go high and return low when the exchange is complete. Following each exchange the Host should query the BLIC's Status Register by pulsing STAT. All flags should be clear.

This section of the TEST Sequence not only checks proper operation of the Serial Register of the BLIC, the TEST,  $\overline{\text{IDLE}}$ , RDY, and STAT pins but it also does an internal verification of >70% of the inputs of the BLIC's State Machine.

### Test Block 2

The TEST Sequence can now be exited by lowering TEST and setting the NXT bit in the Control Register, or the second portion of the TEST Sequence can be invoked by leaving TEST high and doing one last transfer of an \$FF using the **long** form of RDY. Following this exchange the BLIC will send a high TV2 followed by a low TV1 followed by a high noise pulse (to prevent bus interference the HIP7020 Transceiver should be in Loopback Mode during this sequence). Following the noise pulse, the State Machine will return to the start of the TEST Sequence and  $\overline{\text{IDLE}}$  will go low. If all tests were successful the ERR bit should be set in the Status Register (due to the noise pulse) and the Serial Data Register should have been set to \$00 (done following the TV1). This can be verified by doing a STAT transfer followed by a RDY transfer. Normally the TEST Sequence would now be exited by lowering TEST and setting NXT in the Control Register.

The second block of the TEST Sequence boosts the number of tested State Machine inputs to over 90%.

### Using TEST for Loopback Operation

Whenever TEST is high the BLIC is operating in "loopback" mode. This provides a convenient means to isolate faults between the Bus, the Transceiver, and the BLIC. It also simplifies extended testing of the BLIC's Symbol Generation/Detection, Message Handling and CRC Generation/Detection logic.

To isolate Module faults from Bus faults: place the HIP7020 Transceiver in loopback (by lowering  $\overline{\text{LBE}}$ ) and send a message. Verify the message and CRC are properly reflected and the Status bits are clear. If all are good, the fault can be assumed to be on the output of the Transceiver or on the bus itself. If all are not good, leave the Transceiver in loopback and place the BLIC in loopback (to place the BLIC in loopback, wait for  $\overline{\text{IDLE}}$  to go low and then raise TEST) and send a message again verifying that the message and CRC are properly reflected and that the Status bits are clear. If all are good the Transceiver or VPWOUT or VPWIN of the BLIC are faulty. If all are not good the fault is either internal to the BLIC or is a problem with the Host/BLIC interface. If the TEST Sequence can be properly run the problem has been isolated to an internal fault of the HIP7010.

## Error Handling

### The Status Register

The various flags in the Status Register can be used to detect many errors which would typically be generated by system noise, errant nodes, or improperly designed Host code. It is good practice to maintain error counts in the Host for service reporting and to trigger recovery procedures. Whenever the ERR or CRC are set in the Status Register, the current message is aborted and the BLIC enters a “wait for Idle” mode. Following is a detailed listing of the errors which can be trapped by reading the Status Register.

### Errors Which Set the ERR Flag

The ERR flag will be set whenever:

1. A noise pulse (i.e., a symbol less than  $TV1_{MIN}$ ) is received - including while waiting for an Idle.
2. An illegal symbol, (i.e., a symbol other than a TV1, TV2, or Break) is received in the middle of a message which is being received or transmitted.
3. A message with an incomplete byte is received (i.e., total data bit count not equal to 0 modulo 8).
4. The Host attempts to initiate a message more than  $TV2_{MIN}$  (96 $\mu$ s) after the IDLE line goes high.
5. An improperly framed message is received (i.e., SOF not equal to TV3, wrong EOD, EOF, or NB widths).
6. An SOF occurs less than TV4 after the end of a Type 0 message.
7. While transmitting a message that the Host fails to assert RDY prior to a data transfer.
8. The Host fails to use the long form of RDY to indicate the last byte of a message.
9. The Host attempts to transmit an IFR by setting ACK but fails to assert RDY prior to 135 $\mu$ s after the CRC.
10. The Host attempts to transmit a single byte (Type 1 or Type 2) IFR by setting ACK but without using the long form of RDY for the **first** byte transfer.
11. The Host asserts STAT during a data byte transfer.
12. While transmitting, a Status/Control Register transfer is in **progress** when a data byte transfer begins.
13. **A transition has occurred on the VPWOUT pin and the reflected transition has not been detected on  $\overline{VPWIN}$  (echo fail).**
14. **A failure occurs during TEST mode.**
15. A **low pulse <7 $\mu$ s** occurs on  $\overline{VPWIN}$  during the POWER-DOWN mode.

### Errors Which Don't Set the ERR Flag

Due to various considerations, some errors which the user might otherwise expect to be trapped by ERR are not. These include:

1. A zero length message (SOF followed by EOD) will not set ERR, but will set the CRC flag.
2. Any symbol, other than a noise pulse, is ignored while

waiting for an Idle. That is to say that the current message is discarded. “Waiting for Idle” happens following: Reset, setting of NXT, any error which sets ERR (except asserting STAT during a data transfer), a CRC error, a Break, or following EOD after a Type 1, 2, or 3 message.

3. **After a** Type 1, 2, or 3 message, a second NB or an SOF for a new message received before EOF will be ignored. Any following symbols will be ignored until EOF is detected. This implies that if two messages appear on the bus with less than an EOF between them the second message will be ignored, but no error generated. Similarly, if an IFR is attached to a message after EOD and a second NB is generated an EOD after the initial IFR, the NB and all succeeding symbols will be ignored until Idle is detected. No error will be generated.

### Errors Which Set the CRC Flag

The CRC flag will be set whenever:

1. The CRC check byte of the body of any type message is bad (any IFR will be aborted/ignored).
2. All components of a Type 3 message frame are good except the IFR's CRC check byte.
3. A zero length message (SOF followed by EOD) is received.

### Host Time-outs

Other classes of errors, including catastrophic failure of the J1850 bus, can sometimes only be detected by monitoring the time between successfully received messages and/or the delay between IDLEs - when the time exceeds some limit the Host assumes that a bus fault exists and attempt to isolate the cause (perhaps using the TEST pin) and perform recovery/“limp home” actions.

### Error Recovery

If errors are detected on multiple occasions or a Host time-out occurs, the BLIC should be reset by lowering  $\overline{RESET}$  or stopping the CLK (or setting NXT if the  $\overline{RESET}$  or CLK pin is not controllable), and DS2-0 should be re-initialized in the Control Register.

If resetting the BLIC doesn't eliminate the error condition, a test procedure should be entered using TEST and loopback modes.

# HIP7010

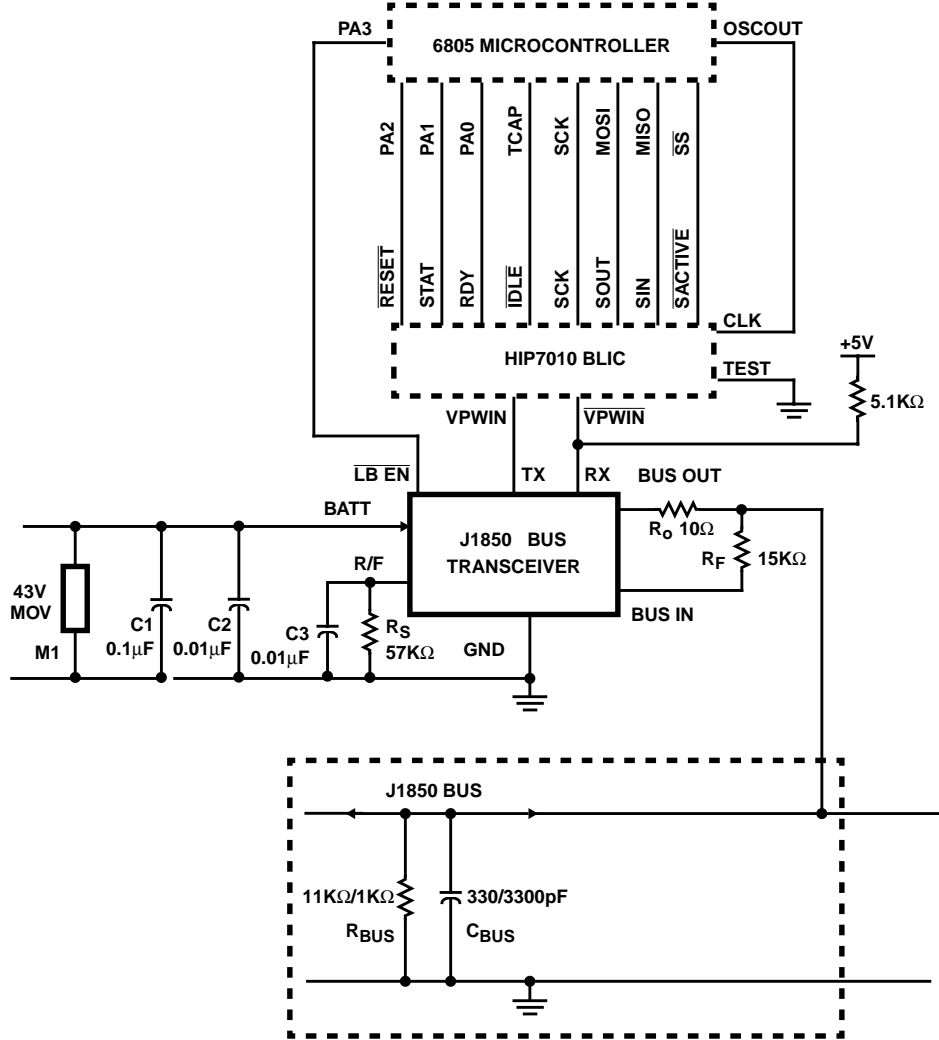
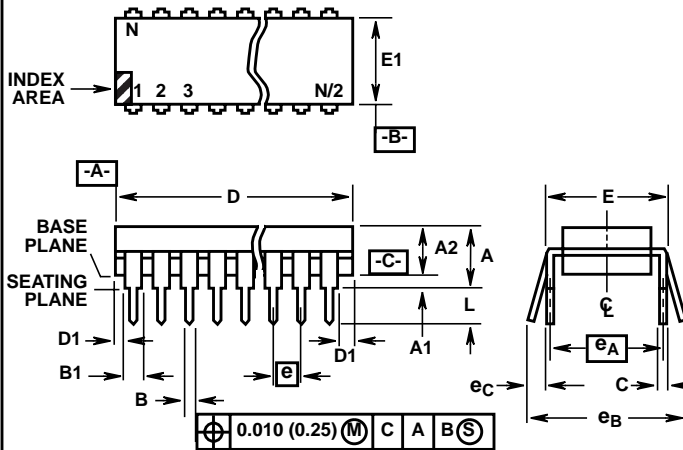

FIGURE 8.

Dual-In-Line Plastic Packages (PDIP)



NOTES:

- Controlling Dimensions: INCH. In case of conflict between English and Metric dimensions, the inch dimensions control.
- Dimensioning and tolerancing per ANSI Y14.5M-1982.
- Symbols are defined in the "MO Series Symbol List" in Section 2.2 of Publication No. 95.
- Dimensions A, A1 and L are measured with the package seated in JEDEC seating plane gauge GS-3.
- D, D1, and E1 dimensions do not include mold flash or protrusions. Mold flash or protrusions shall not exceed 0.010 inch (0.25mm).
- E and  $e_A$  are measured with the leads constrained to be perpendicular to datum  $-C-$ .
- $e_B$  and  $e_C$  are measured at the lead tips with the leads unconstrained.  $e_C$  must be zero or greater.
- B1 maximum dimensions do not include dambar protrusions. Dambar protrusions shall not exceed 0.010 inch (0.25mm).
- N is the maximum number of terminal positions.
- Corner leads (1, N, N/2 and N/2 + 1) for E8.3, E16.3, E18.3, E28.3, E42.6 will have a B1 dimension of 0.030 - 0.045 inch (0.76 - 1.14mm).

E14.3 (JEDEC MS-001-AA ISSUE D)  
14 LEAD DUAL-IN-LINE PLASTIC PACKAGE

SYMBOL	INCHES		MILLIMETERS		NOTES
	MIN	MAX	MIN	MAX	
A	-	0.210	-	5.33	4
A1	0.015	-	0.39	-	4
A2	0.115	0.195	2.93	4.95	-
B	0.014	0.022	0.356	0.558	-
B1	0.045	0.070	1.15	1.77	8
C	0.008	0.014	0.204	0.355	-
D	0.735	0.775	18.66	19.68	5
D1	0.005	-	0.13	-	5
E	0.300	0.325	7.62	8.25	6
E1	0.240	0.280	6.10	7.11	5
e	0.100 BSC		2.54 BSC		-
$e_A$	0.300 BSC		7.62 BSC		6
$e_B$	-	0.430	-	10.92	7
L	0.115	0.150	2.93	3.81	4
N	14		14		9

Rev. 0 12/93

**Small Outline Plastic Packages (SOIC)**

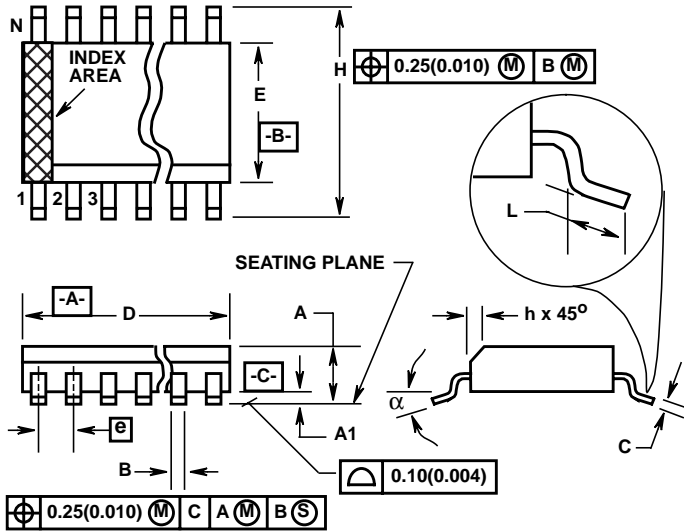

**M14.15 (JEDEC MS-012-AB ISSUE C)  
14 LEAD NARROW BODY SMALL OUTLINE PLASTIC PACKAGE**

SYMBOL	INCHES		MILLIMETERS		NOTES
	MIN	MAX	MIN	MAX	
A	0.0532	0.0688	1.35	1.75	-
A1	0.0040	0.0098	0.10	0.25	-
B	0.013	0.020	0.33	0.51	9
C	0.0075	0.0098	0.19	0.25	-
D	0.3367	0.3444	8.55	8.75	3
E	0.1497	0.1574	3.80	4.00	4
e	0.050 BSC		1.27 BSC		-
H	0.2284	0.2440	5.80	6.20	-
h	0.0099	0.0196	0.25	0.50	5
L	0.016	0.050	0.40	1.27	6
N	14		14		7
$\alpha$	0°	8°	0°	8°	-

**NOTES:**

- Symbols are defined in the "MO Series Symbol List" in Section 2.2 of Publication Number 95.
- Dimensioning and tolerancing per ANSI Y14.5M-1982.
- Dimension "D" does not include mold flash, protrusions or gate burrs. Mold flash, protrusion and gate burrs shall not exceed 0.15mm (0.006 inch) per side.
- Dimension "E" does not include interlead flash or protrusions. Interlead flash and protrusions shall not exceed 0.25mm (0.010 inch) per side.
- The chamfer on the body is optional. If it is not present, a visual index feature must be located within the crosshatched area.
- "L" is the length of terminal for soldering to a substrate.
- "N" is the number of terminal positions.
- Terminal numbers are shown for reference only.
- The lead width "B", as measured 0.36mm (0.014 inch) or greater above the seating plane, shall not exceed a maximum value of 0.61mm (0.024 inch).
- Controlling dimension: MILLIMETER. Converted inch dimensions are not necessarily exact.

Rev. 0 12/93

All Intersil semiconductor products are manufactured, assembled and tested under **ISO9000** quality systems certification.

*Intersil products are sold by description only. Intersil Corporation reserves the right to make changes in circuit design and/or specifications at any time without notice. Accordingly, the reader is cautioned to verify that data sheets are current before placing orders. Information furnished by Intersil is believed to be accurate and reliable. However, no responsibility is assumed by Intersil or its subsidiaries for its use; nor for any infringements of patents or other rights of third parties which may result from its use. No license is granted by implication or otherwise under any patent or patent rights of Intersil or its subsidiaries.*

For information regarding Intersil Corporation and its products, see web site <http://www.intersil.com>

**Sales Office Headquarters**

**NORTH AMERICA**  
Intersil Corporation  
P. O. Box 883, Mail Stop 53-204  
Melbourne, FL 32902  
TEL: (407) 724-7000  
FAX: (407) 724-7240

**EUROPE**  
Intersil SA  
Mercure Center  
100, Rue de la Fusee  
1130 Brussels, Belgium  
TEL: (32) 2.724.2111  
FAX: (32) 2.724.22.05

**ASIA**  
Intersil (Taiwan) Ltd.  
Taiwan Limited  
7F-6, No. 101 Fu Hsing North Road  
Taipei, Taiwan  
Republic of China  
TEL: (886) 2 2716 9310  
FAX: (886) 2 2715 3029

This datasheet has been downloaded from:

[www.DatasheetCatalog.com](http://www.DatasheetCatalog.com)

Datasheets for electronic components.



LittleDiode supplies new, hard to find or obsolete electronic components and semiconductors all over the world.

With over two million different components listed you are sure to find the part you need.

Feel free to visit us today at our online store:

[LittleDiode.com](http://LittleDiode.com)

Looking forward to providing you with the best possible service.